

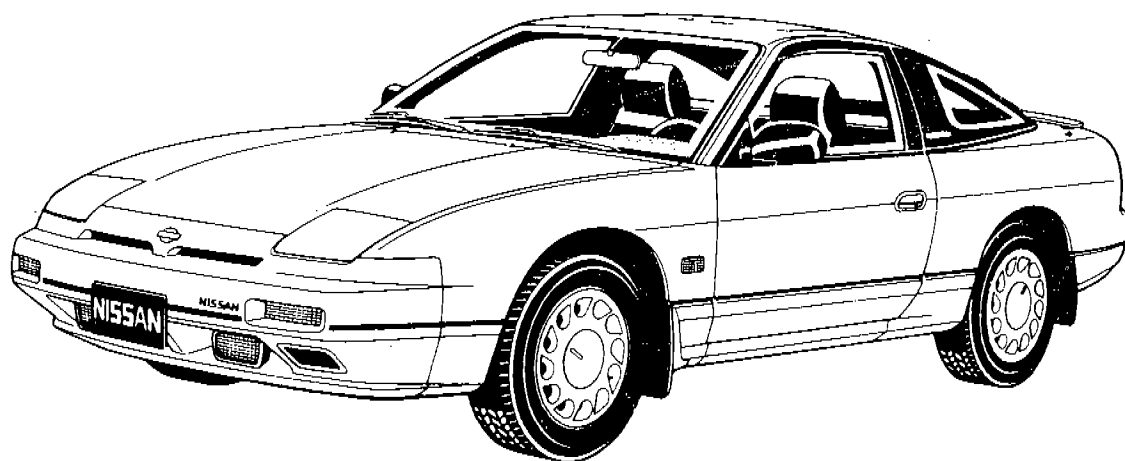

NISSAN 200SX

MODEL S13 SERIES



SERVICE MANUAL

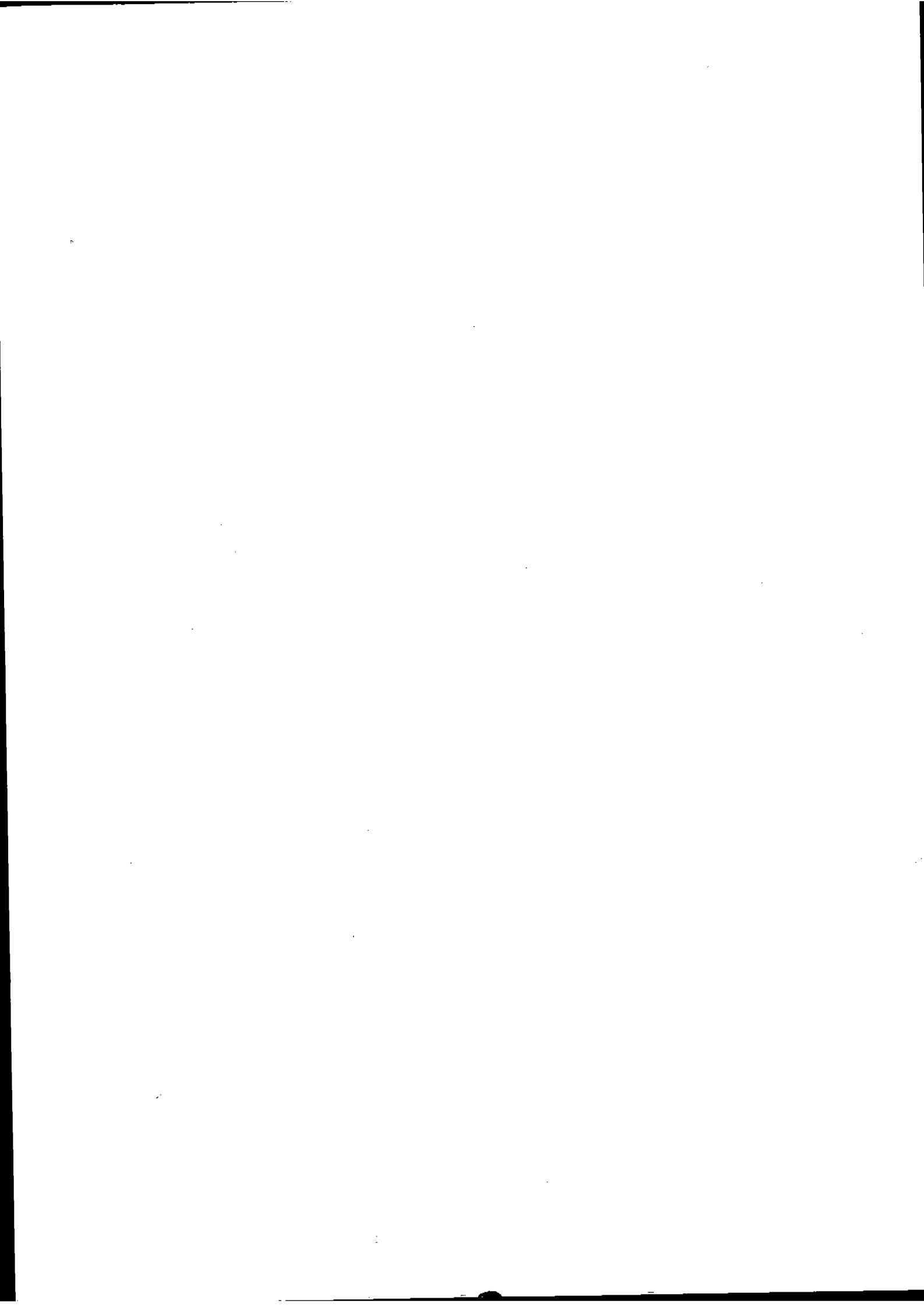

NISSAN 200SX

MODEL S13 SERIES

QUICK REFERENCE INDEX

| | |
|----------------------------------------------|-----|
| GENERAL INFORMATION _____ | GI |
| MAINTENANCE _____ | MA |
| ENGINE MECHANICAL _____ | EM |
| ENGINE LUBRICATION & COOLING SYSTEMS _____ | LC |
| ENGINE FUEL & EMISSION CONTROL SYSTEM _____ | EF& |
| ENGINE CONTROL, FUEL & EXHAUST SYSTEM _____ | FE |
| CLUTCH _____ | CL |
| MANUAL TRANSMISSION _____ | MT |
| AUTOMATIC TRANSMISSION _____ | AT |
| PROPELLER SHAFT & DIFFERENTIAL CARRIER _____ | PD |
| FRONT AXLE & FRONT SUSPENSION _____ | FA |
| REAR AXLE & REAR SUSPENSION _____ | RA |
| BRAKE SYSTEM _____ | BR |
| STEERING SYSTEM _____ | ST |
| BODY _____ | BF |
| HEATER & AIR CONDITIONER _____ | HA |
| ELECTRICAL SYSTEM _____ | EL |

© 1988 NISSAN MOTOR CO., LTD. Printed in Japan

Not to be reproduced in whole or in part without the prior written permission of Nissan Motor Company Ltd., Tokyo, Japan.

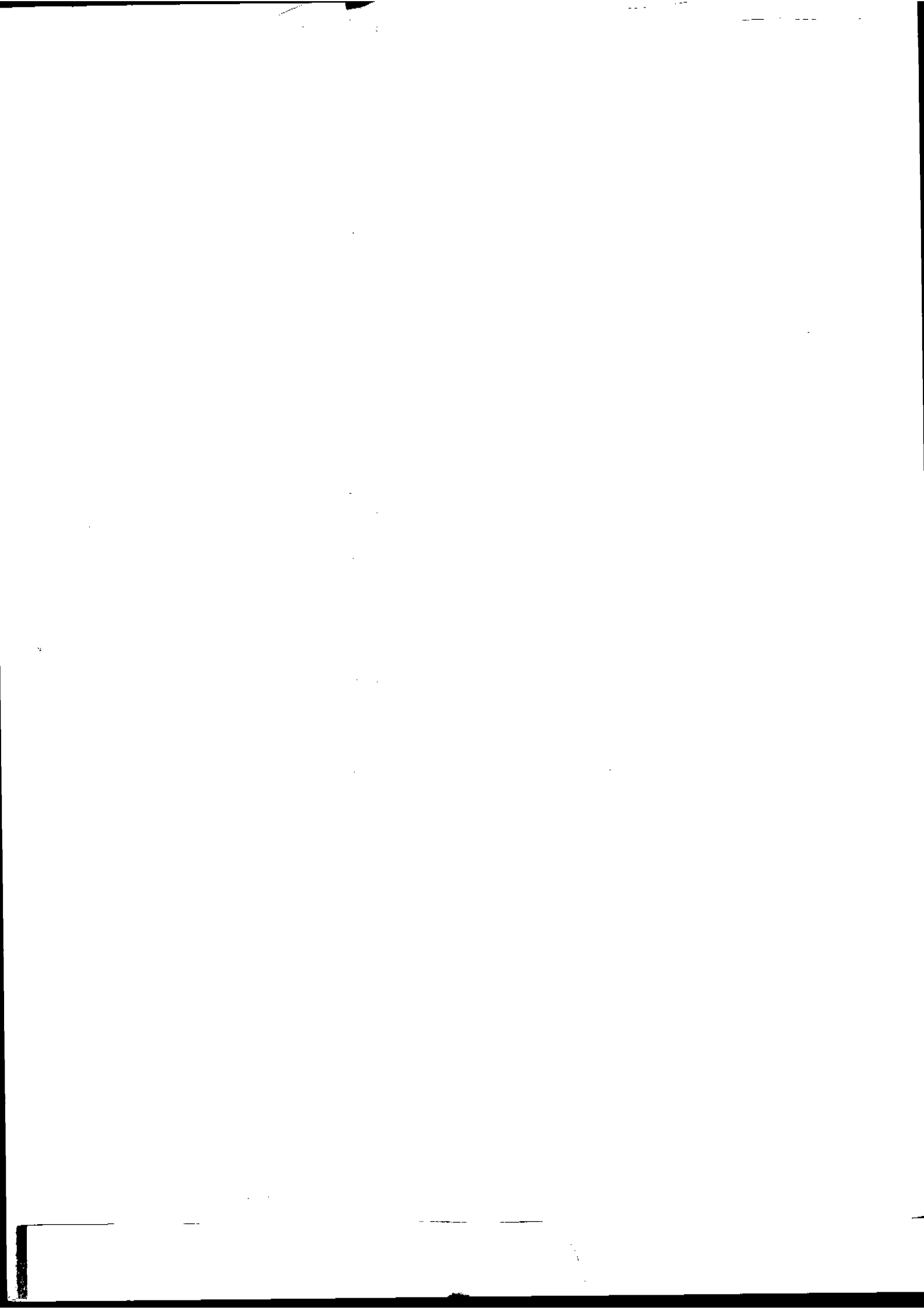

GENERAL INFORMATION

GI

SECTION **GI**

CONTENTS

| | |
|-----------------------------------------------------|-------|
| PRECAUTIONS | GI- 2 |
| HOW TO USE THIS MANUAL | GI- 5 |
| HOW TO READ WIRING DIAGRAMS | GI- 7 |
| HOW TO FOLLOW FLOW CHART IN TROUBLE DIAGNOSES | GI-10 |
| IDENTIFICATION INFORMATION | GI-13 |
| LIFTING POINTS AND TOW TRUCK TOWING | GI-17 |
| TIGHTENING TORQUE OF STANDARD BOLTS | GI-20 |

FOREWORD

This manual contains maintenance and repair procedures for Nissan 200SX, model S13 series.

In order to assure your safety and the efficient functioning of the vehicle, this manual should be read thoroughly. It is especially important that the PRECAUTIONS in the GI section be completely understood before starting any repair task.

All information in this manual is based on the latest product information at the time of publication. The right is reserved to make changes in specifications and methods at any time without notice.

IMPORTANT SAFETY NOTICE

The proper performance of service is essential for both the safety of the technician and the efficient functioning of the vehicle.

The service methods in this Service Manual are described in such a manner that the service may be performed safely and accurately.

Service varies with the procedures used, the skills of the technician and the tools and parts available. Accordingly, anyone using service procedures, tools or parts which are not specifically recommended by NISSAN must first completely satisfy himself that neither his safety nor the vehicle's safety will be jeopardized by the service method selected.



NISSAN MOTOR CO., LTD.

Overseas Service Department

Tokyo, Japan

PRECAUTIONS

Observe the following precautions to ensure safe and proper servicing. These precautions are not described in each individual section.

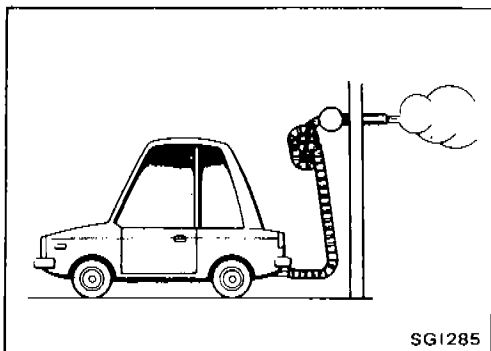

1. Do not operate the engine for an extended period of time without proper exhaust ventilation. Keep the work area well ventilated and free of any inflammable materials. Special care should be taken when handling any inflammable or poisonous materials, such as gasoline, refrigerant gas, etc. When working in a pit or other enclosed area, be sure to properly ventilate the area before working with hazardous materials. Do not smoke while working on the vehicle.

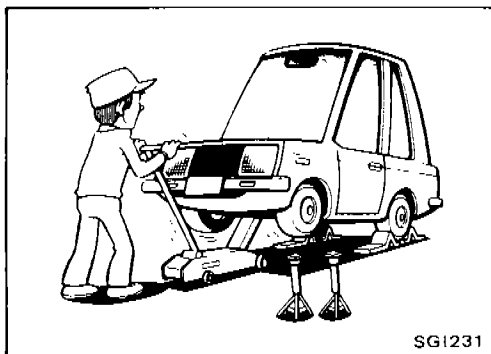

2. Before jacking up the vehicle, apply wheel chocks or other tire blocks to the wheels to prevent the vehicle from moving. After jacking up the vehicle, support the vehicle weight with safety stands at the points designated for proper lifting and towing before working on the vehicle. These operations should be done on a level surface.
3. When removing a heavy component such as the engine or transaxle/transmission, be careful not to lose your balance and drop them. Also, do not allow them to strike adjacent parts, especially the brake tubes and master cylinder.

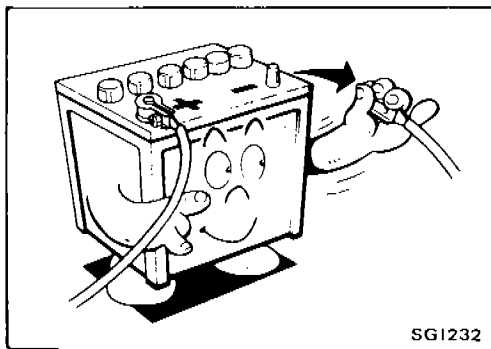

4. Before starting repairs which do not require battery power, always turn off the ignition switch, then disconnect the ground cable from the battery to prevent accidental short circuit.

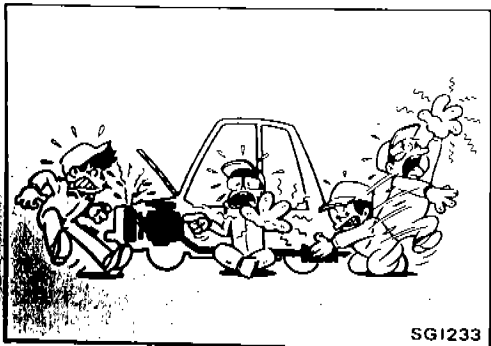

5. To prevent serious burns, avoid contact with hot metal parts such as the radiator, exhaust manifold, tail pipe and muffler. Do not remove the radiator cap when the engine is hot.

PRECAUTIONS

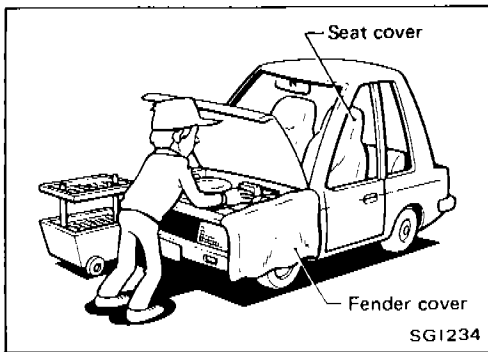

6. Before servicing the vehicle, protect fenders, upholstery and carpeting with appropriate covers. Take caution that keys, buckles or buttons on your person do not scratch the paint.
7. Clean all disassembled parts in the designated liquid or solvent prior to inspection or assembly.
8. Replace oil seals, gaskets, packings, O-rings, locking washers, cotter pins, self-locking nuts, etc. with new ones.
9. Replace inner and outer races of tapered roller bearings and needle bearings as a set.
10. Arrange the disassembled parts in accordance with their assembled locations and sequence.
11. Do not touch the terminals of electrical components which use microcomputers (such as electronic control units). Static electricity may damage internal electronic components.
12. After disconnecting vacuum or air hoses, attach a tag to indicate the proper connection.
13. Use only the lubricants specified in MA section.
14. Use approved bonding agent, sealants or their equivalents when required.
15. Use tools and recommended special tools where specified for safe and efficient service repairs.
16. When repairing the fuel, oil, water, vacuum or exhaust systems, check all affected lines for leaks.
17. Dispose of drained oil or the solvent used for cleaning parts in an appropriate manner.

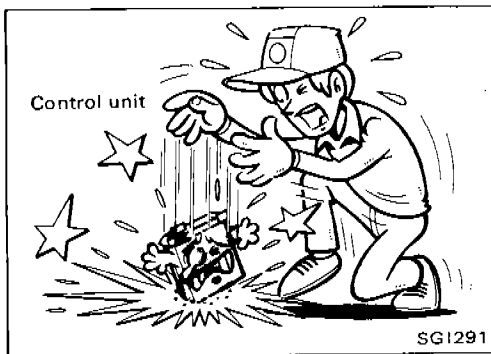

Precautions for E.F.I. or E.C.C.S. Engine

1. Before connecting or disconnecting E.F.I. or E.C.C.S. harness connector to or from any E.F.I. or E.C.C.S. control unit, be sure to turn the ignition switch to the "OFF" position and disconnect the negative battery terminal. Otherwise, there may be damage to control unit.
2. Before disconnecting pressurized fuel line from fuel pump to injectors, be sure to release fuel pressure to eliminate danger.
3. Be careful not to jar components such as control unit and air flow meter.

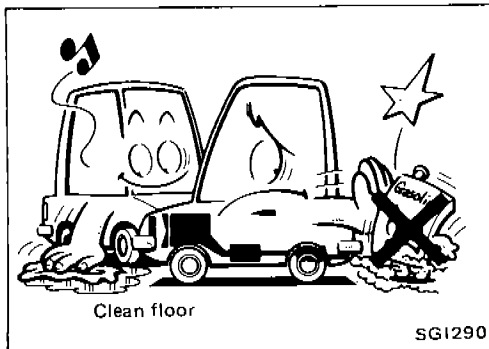

Precautions for Catalyst

If a large amount of unburned fuel flows into the converter, the converter temperature will be excessively high. To prevent this, follow the procedure below:

1. Use unleaded gasoline only. Leaded gasoline will seriously damage the catalytic converter.
2. When checking for ignition spark or measuring engine compression, make tests quickly and only when necessary.
3. Do not run engine when the fuel tank level is low, otherwise the engine may misfire causing damage to the converter.
4. Do not place the vehicle on inflammable material. Keep inflammable material off the exhaust pipe.

PRECAUTIONS

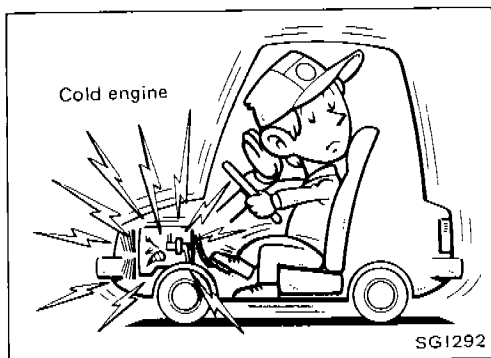

Precautions for Turbocharger

The turbocharger system uses engine oil for lubrication and cooling of its rotating components. The turbocharger turbine turns at a speed in excess of 100,000 rpm at full throttle and its temperature can reach 870°C (1,600°F). It is essential to maintain a clean supply of oil flowing through the turbocharger system. Therefore, a sudden interruption of oil supply may cause a malfunction in the turbocharger.

For proper operation of the system, follow the procedure below:

1. Always use the recommended oil. Follow the instructions for proper time to change the oil and proper oil level.
2. Avoid accelerating engine to a high rpm immediately after starting.
3. If engine had been operating at high rpm for an extended period of time, let it idle for a few minutes prior to shutting it off.

Asbestos Safety Instructions

(Based on regulations of United Kingdom)

This vehicle uses parts containing asbestos, most are not hazardous but Brake and Clutch linings can be. Consult the manufacturer or his agent for further details. When working with these please observe the "Garage Workers' Asbestos Code" available through your Nissan Dealer, Local Authority or Health and Safety Executive. In particular, work in a well-ventilated place using where possible appropriate dust extraction equipment and avoid creating dust. Dampen all asbestos/dust where possible prior to machining, cutting, cleaning, etc. Use only hand or low speed tools.

Dispose of all asbestos waste, wet rags, etc., in a closed container as directed by your local waste disposal authority.

Precautions for Fuel

EUROPE

CA18DET with catalytic converter:

Unleaded gasoline of at least 95 octane (RON)

CA18DET without catalytic converter:

Leaded or unleaded gasoline of at least 95 octane (RON)

EXCEPT EUROPE

Leaded gasoline of at least 95 octane (RON)

HOW TO USE THIS MANUAL

1. **A QUICK REFERENCE INDEX**, a black tab (e.g. **BR**) is provided on the first page. You can quickly find the first page of each section by mating it to the section's black tab.
2. **THE CONTENTS** are listed on the first page of each section.
3. **THE TITLE** is indicated on the upper portion of each page and shows the part or system.
4. **THE PAGE NUMBER** of each section consists of two letters which designate the particular section and a number (e.g. "BR-5").
5. **THE LARGE ILLUSTRATIONS** are exploded views (See below) and contain tightening torques, lubrication points and other information necessary to perform repairs. The illustrations should be used in reference to service matters only. When ordering parts, refer to the appropriate **PARTS CATALOG**.

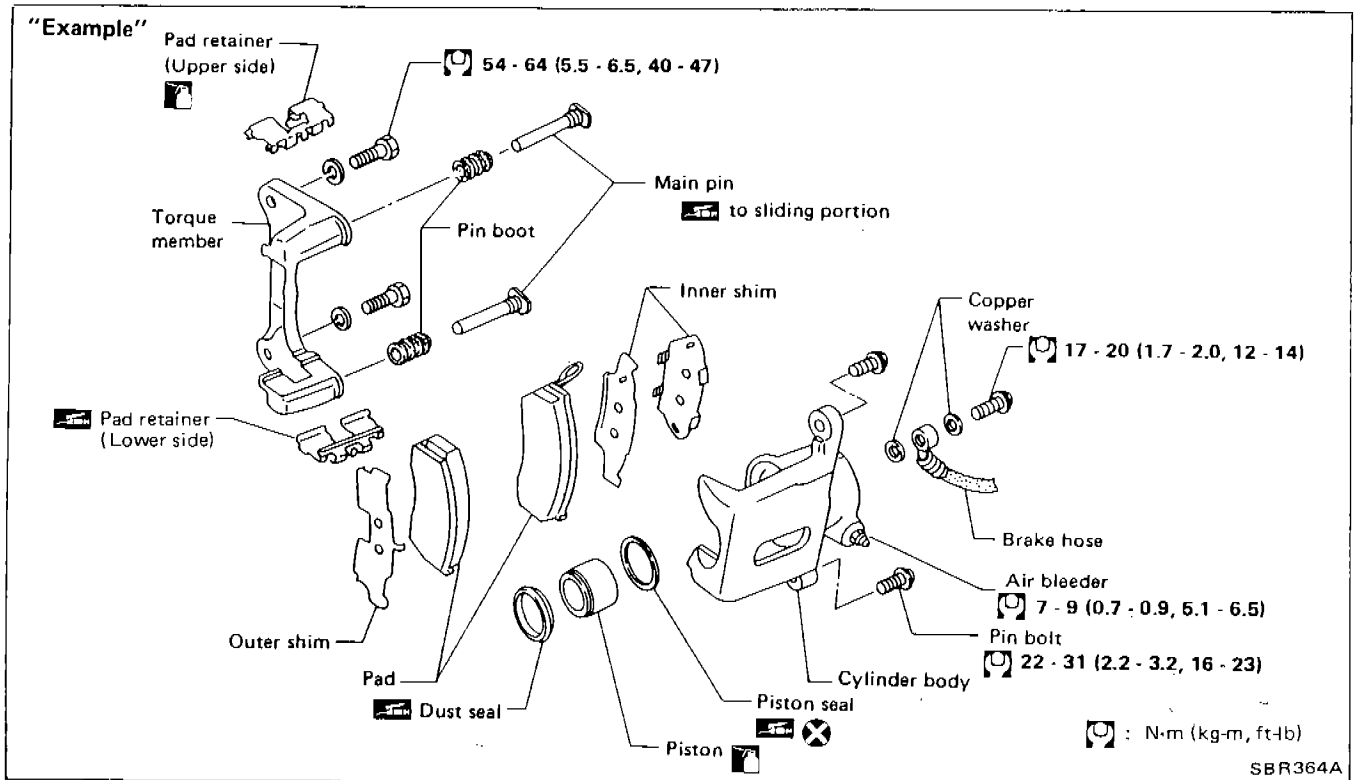

6. **THE SMALL ILLUSTRATIONS** show the important steps such as inspection, use of special tools, knacks of work and hidden or tricky steps which are not shown in the previous large illustrations. Assembly, inspection and adjustment procedures for the complicated units such as the automatic transaxle or transmission, etc. are presented in a step-by-step format where necessary.

7. The following **SYMBOLS AND ABBREVIATIONS** are used:

| | | | |
|------------|----------------------------------------------------------------------------------------------------------|--------|-----------------------------------------|
| | : Tightening torque | 4WD | : 4-Wheel Drive |
| | : Should be lubricated with grease. Unless otherwise indicated, use recommended multi-purpose grease. | M/T | : Manual Transaxle/Transmission |
| | : Should be lubricated with oil. | A/T | : Automatic Transaxle/Transmission |
| | : Sealing point | A/C | : Air Conditioner |
| | : Checking point | P/S | : Power Steering |
| | : Always replace after every disassembly. | S.S.T. | : Special Service Tools |
| L.H., R.H. | : Left-Hand, Right-Hand | S.D.S. | : Service Data and Specifications |
| FR, RR | : Front, Rear | SAE | : Society of Automotive Engineers, Inc. |
| 2WD | : 2-Wheel Drive | G.C.C. | : Gulf Cooperation Council |
| | | L.H.D. | : Left-Hand Drive |
| | | R.H.D. | : Right-Hand Drive |

HOW TO USE THIS MANUAL

8. The **UNITS** given in this manual are primarily expressed as the SI UNIT (International System of Unit), and alternatively expressed in the metric system and in the yard/pound system.

"Example"

Tightening torque

59 - 78 N·m (6.0 - 8.0 kg-m, 43 - 58 ft-lb)

9. **TROUBLE DIAGNOSES** are included in sections dealing with complicated components.
10. **SERVICE DATA AND SPECIFICATIONS** are contained at the end of each section for quick reference of data.
11. The captions **WARNING** and **CAUTION** warn you of steps that must be followed to prevent personal injury and/or damage to some part of the vehicle.
- **WARNING** indicates the possibility of personal injury if instructions are not followed.
 - **CAUTION** indicates the possibility of component damage if instructions are not followed.
 - **BOLD TYPED STATEMENTS** except **WARNING** and **CAUTION** give you helpful information.

HOW TO READ WIRING DIAGRAMS

WIRING DIAGRAM

Symbols used in WIRING DIAGRAM are shown below:

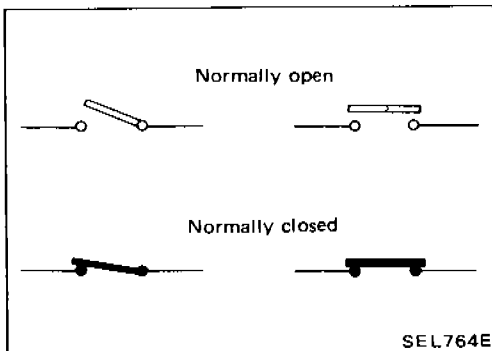
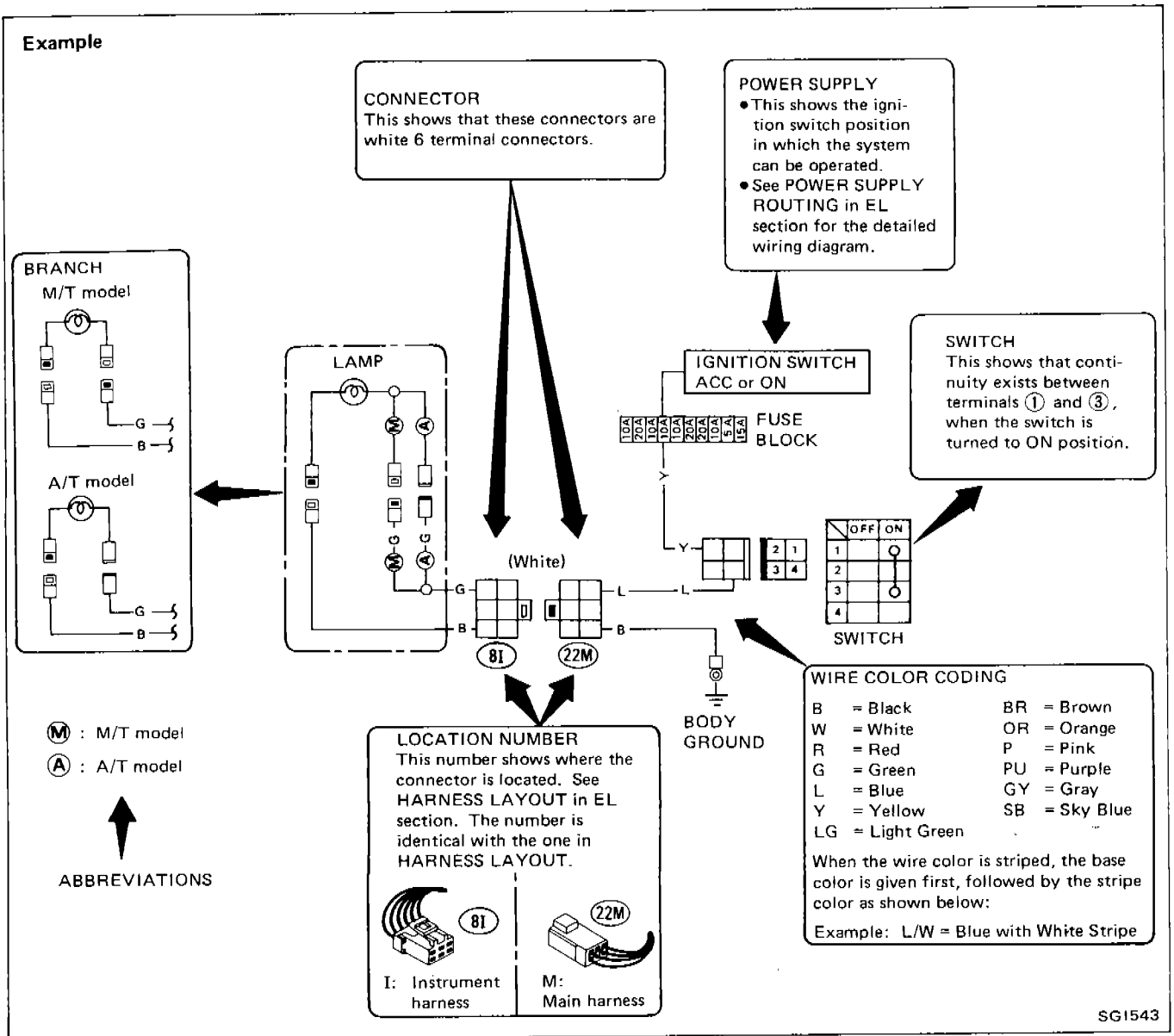

SWITCH POSITIONS

Wiring diagram switches are shown with the vehicle in the following condition.

- Ignition switch "OFF".
- Doors, hood and trunk lid/back door closed.
- Pedals are not depressed and parking brake is released.

HOW TO READ WIRING DIAGRAMS

Example

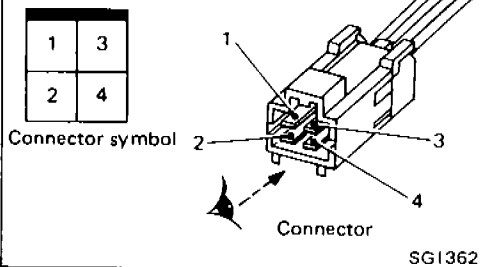

CONNECTOR SYMBOLS

- All connector symbols in wiring diagrams are shown from the terminal side.

Example

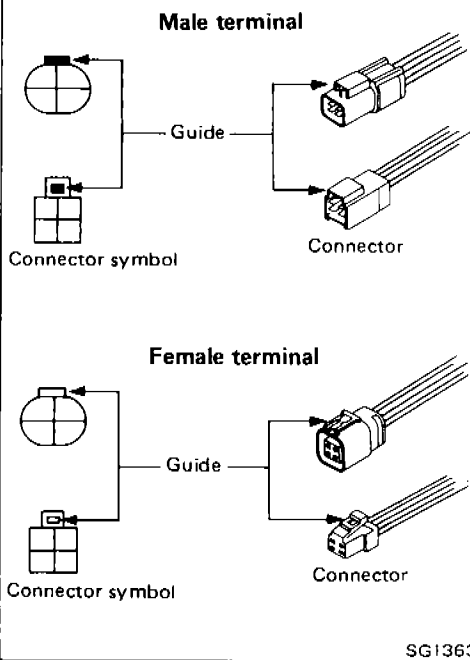

- Male and female terminals
Connector guides for male terminals are shown in black and female terminals in white in wiring diagrams.

MULTIPLE SWITCH

The continuity of the multiple switch is identified in the switch chart in wiring diagrams.

Example

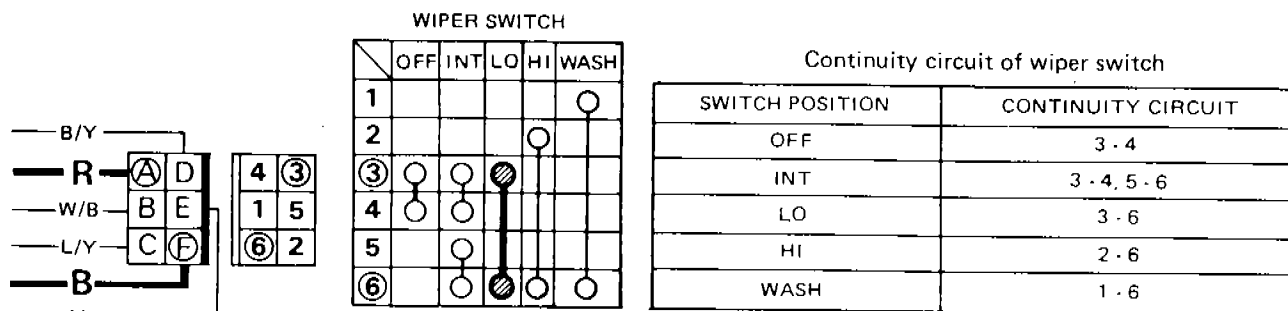

Example: Wiper switch in LO position

Continuity circuit: Red wire - (A) terminal - (3) terminal - Wiper switch (● - ●):
LO) - (6) terminal - (F) terminal - Black wire

SGI365

HOW TO READ WIRING DIAGRAMS

SUPER MULTIPLE JUNCTION (S.M.J.)

- The "S.M.J." indicated in wiring diagrams is shown in a simplified form. The terminal arrangement should therefore be referred to in the foldout at the end of the Service Manual.
- The foldout should be spread to read the entire wiring diagram.

Example

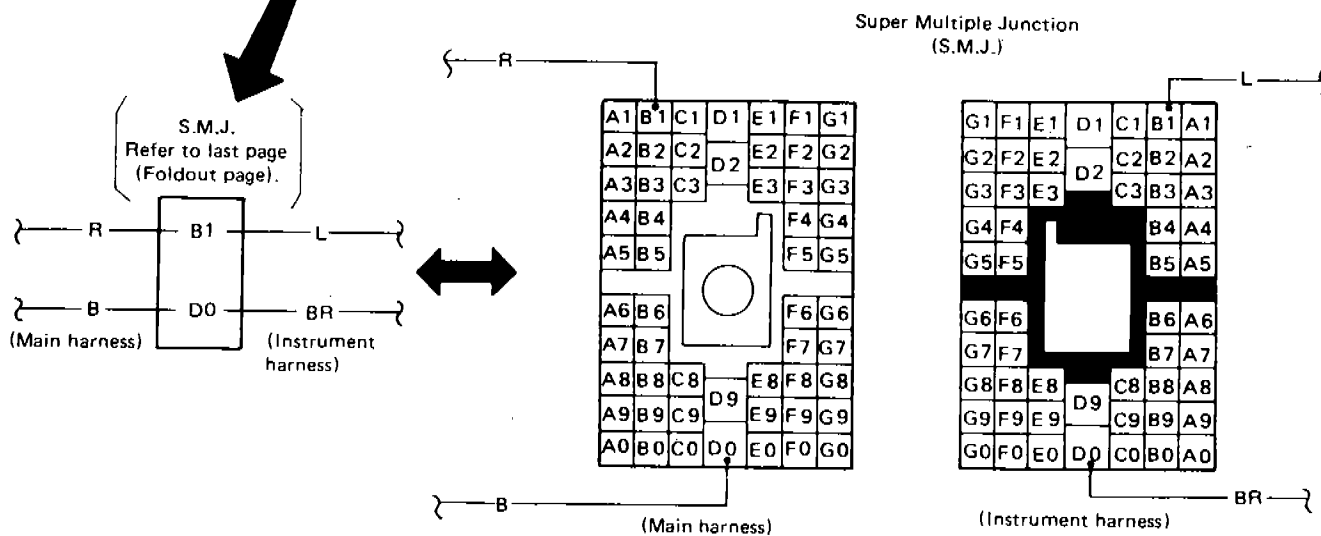
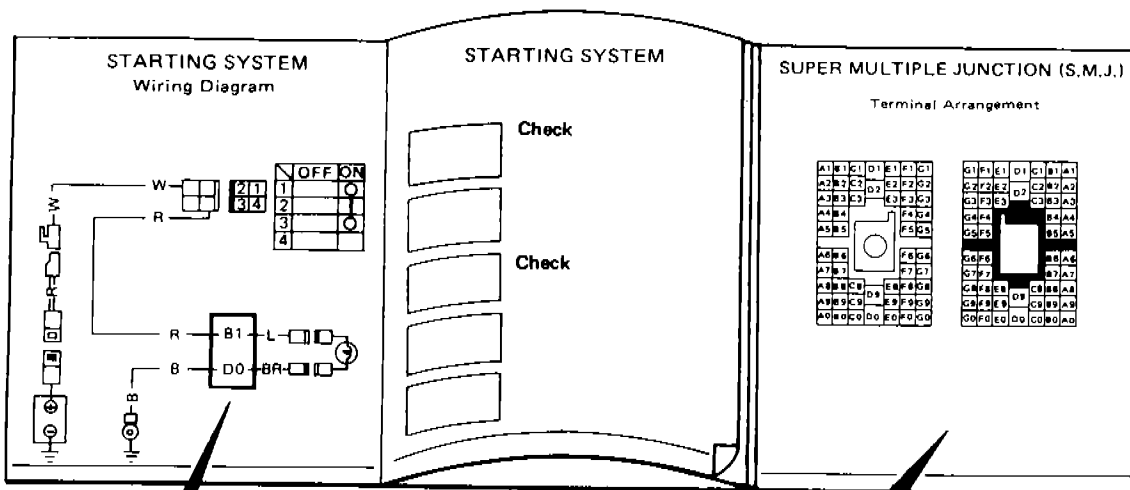

SEL653F

HOW TO FOLLOW FLOW CHART IN TROUBLE DIAGNOSES

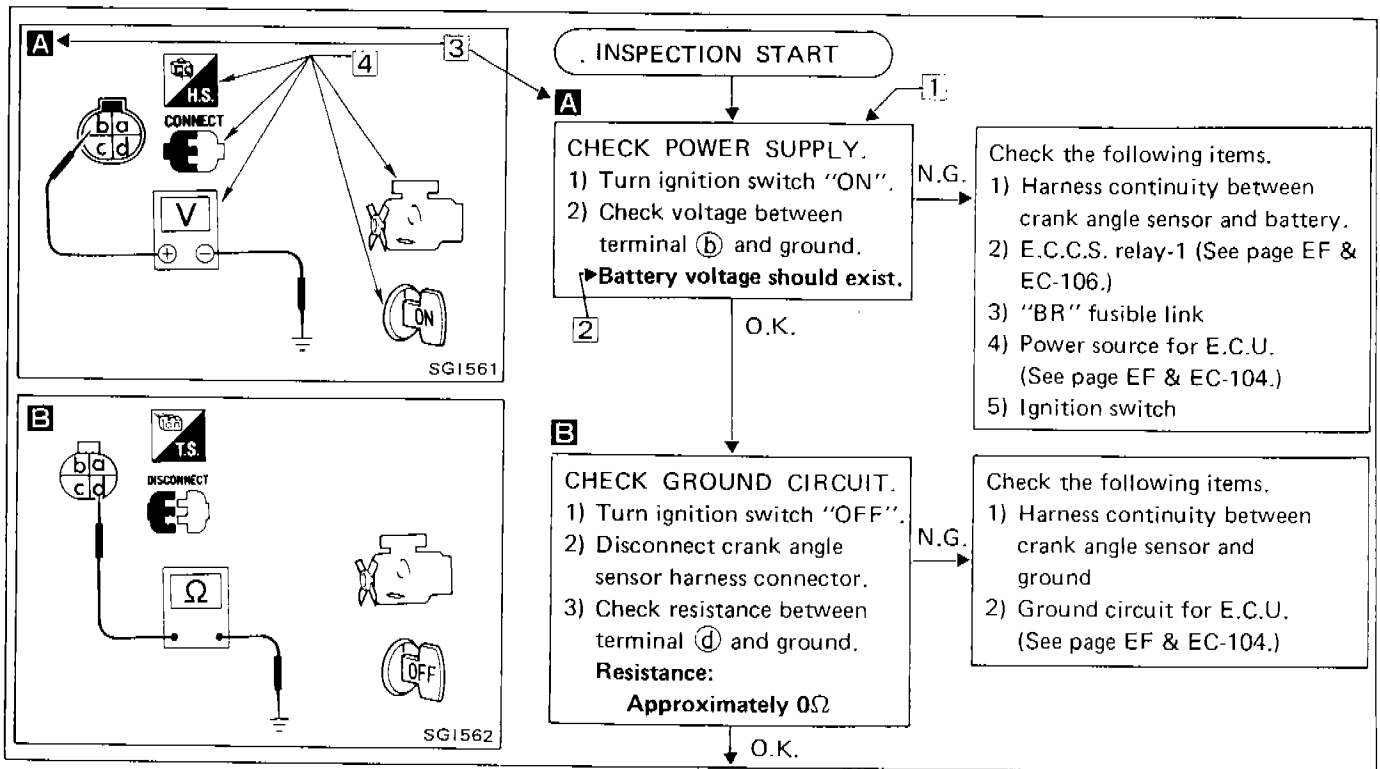

NOTICE

The flow chart indicates work procedures required to diagnose problems effectively. Observe the following instructions before diagnosing.

- 1) Use the flow chart after locating probable causes of a problem following the "Preliminary Check" or the "Symptom Chart".
- 2) After repairs, recheck that the problem has been completely eliminated.
- 3) Refer to Component Parts Location and Harness Layout for the Systems described in each section for identification/location of components and harness connectors.
- 4) Refer to the Circuit Diagram for Quick Pinpoint Check. If you must perform circuit continuity between harness connectors more detail, such as in case of sub-harness is used, refer to Wiring Diagram and Harness Layout in EL section for identification of harness connectors.
- 5) When checking circuit continuity, ignition switch should be "OFF".
- 6) Before checking voltage at connectors, check battery voltage.
- 7) After accomplishing the Diagnostic Procedures and Electrical Components Inspection, make sure that all harness connectors are reconnected as it was.

HOW TO FOLLOW THIS FLOW CHART

1 Work and diagnostic procedure

Start to diagnose a problem using procedures indicated in enclosed blocks, as shown in the following example.

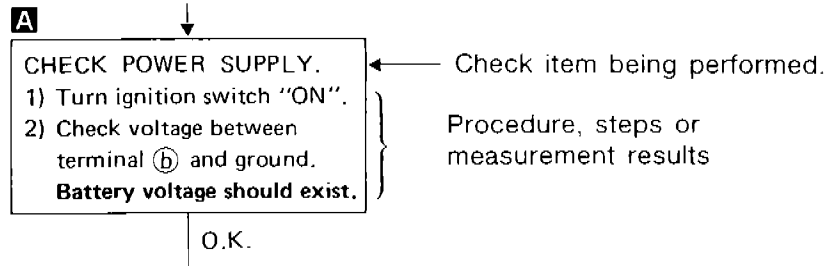

2 Measurement results

Required results are indicated in bold type in the corresponding block, as shown below:

These have the following meanings:

Battery voltage → 11 - 14V or approximately 12V
Voltage: Approximately 0V → Less than 1V

3 Cross reference of work symbols in the text and illustrations

Illustrations are provided as visual aids for work procedures. For example, symbol **A** indicated in the left upper portion of each illustration corresponds with the symbol in the flowchart for easy identification. More precisely, the procedure under the "CHECK POWER SUPPLY." outlined previously is indicated by an illustration **A**.

4 Symbols used in illustrations

Symbols included in illustrations refer to measurements or procedures. Before diagnosing a problem, familiarize yourself with each symbol.

Direction mark

A direction mark is shown to clarify the side of connector (terminal side or harness side).

Direction marks are mainly used in the illustrations indicating terminal inspection.



: View from terminal side ... T.S.

- All connector symbols shown from the terminal side are enclosed by a single line.







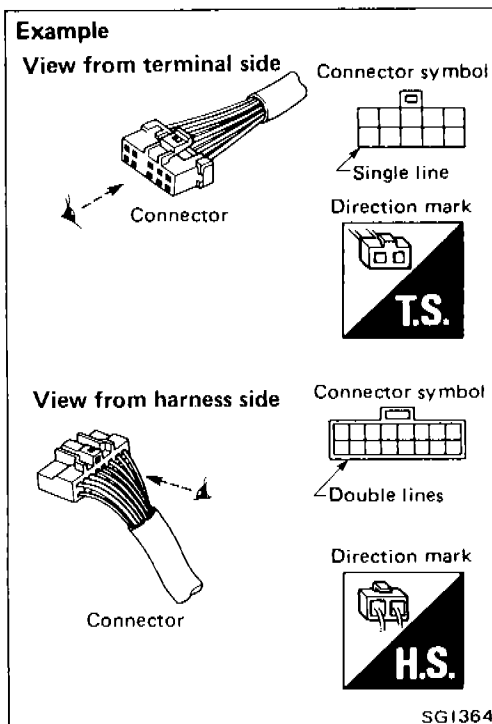

















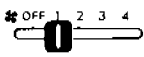

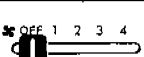

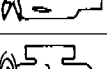

: View from harness side ... H.S.

- All connector symbols shown from the harness side are enclosed by a double line.



HOW TO FOLLOW FLOW CHART IN TROUBLE DIAGNOSES

Key to symbols signifying measurements or procedures

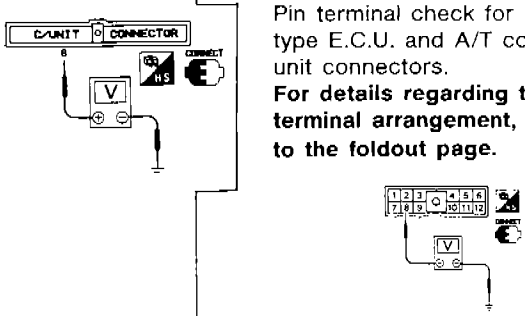
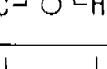
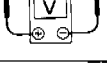
| Symbol | Symbol explanation | Symbol | Symbol explanation |
|-------------------------------------------------------------------------------------|---------------------------------------------------------|---------------------------------------------------------------------------------------------------------------------------------------------------------------------------------------------------------------------------------------------------------------|-----------------------------------------------------------------|
|  | Check after disconnecting the connector to be measured. |  | A. C switch is "OFF". |
|  | Check after connecting the connector to be measured. |  | A. C switch is "ON". |
|  | Insert key into ignition switch. |  | REC switch is "ON". |
|  | Turn ignition switch to "OFF" position. |  | REC switch is "OFF". |
|  | Turn ignition switch to "ON" position. |  | DEF switch is "ON". |
|  | Turn ignition switch to "START" position. |  | VENT switch is "ON". |
|  | Turn ignition switch from "OFF" to "ACC" position. |  | Fan switch is "ON". (At any position except for "OFF" position) |
|  | Turn ignition switch from "ACC" to "OFF" position. |  | Fan switch is "OFF". |
|  | Turn ignition switch from "OFF" to "ON" position. |  | Apply battery voltage directly to components. |
|  | Turn ignition switch from "ON" to "OFF" position. |  | Drive vehicle. |
|  | Do not start engine, or check with engine stopped. |  | Disconnect battery negative cable. |
|  | Start engine, or check with engine running. |  | Depress brake pedal. |
|  | Apply parking brake. |  | Release brake pedal. |
|  | Release parking brake. |  | Depress accelerator pedal. |
|  | Check after engine is warmed up sufficiently. |  | Release accelerator pedal. |
|  | Voltage should be measured with a voltmeter. |  <p>Pin terminal check for S.M.J. type E.C.U. and A/T control unit connectors. For details regarding the terminal arrangement, refer to the foldout page.</p> | |
|  | Circuit resistance should be measured with an ohmmeter. | | |
|  | Current should be measured with an ammeter. | | |

IDENTIFICATION INFORMATION

Model Variation

| Desti- nation | Body | Model | | | Engine | Transmission | Differential carrier |
|------------------|-----------|--------------------------------|-----------------------------------|------------|---------|--------------|-------------------------|
| | | L.H. drive | | R.H. drive | | | |
| | | With catalytic converter | Without catalytic converter | | | | |
| Europe | Fast Back | — | — | RS13FTQ | CA18DET | FS5W71C | R200 |
| | | — | — | RS13ATQ | | RE4R01A | |
| | | RLS13FTO | — | — | | FS5W71C | |
| | | RLS13ATO | — | — | | RE4R01A | |
| | | — | RLS13FTQ | — | | FS5W71C | |
| | | — | RLS13ATQ | — | | RE4R01A | |
| Except Europe | | — | | RS13FTU | | FS5W71C | |
| | | — | | RS13ATU | | RE4R01A | |
| | — | RLS13FT | — | FS5W71C | | | |
| | — | RLS13AT | — | RE4R01A | | | |

Prefix and suffix designations

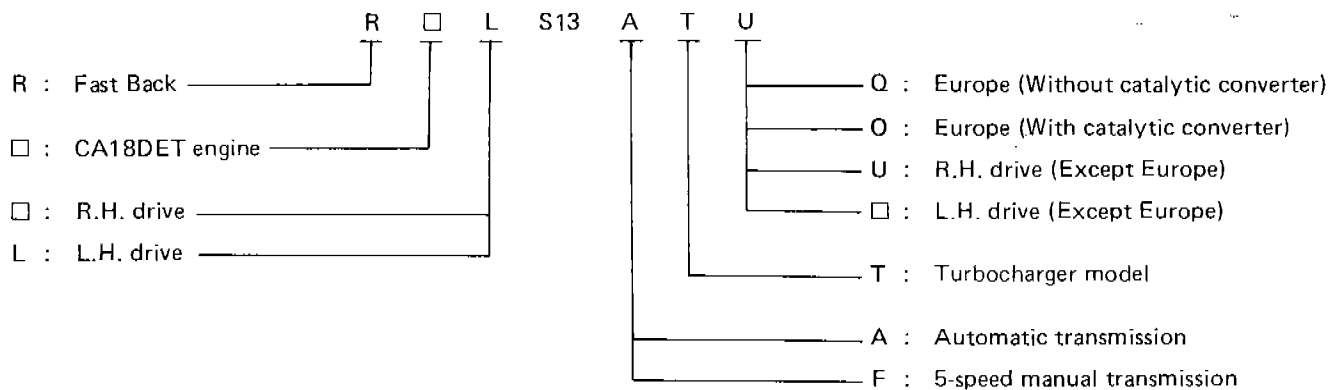

□ : means no indication.

IDENTIFICATION INFORMATION

Key

Identification Number

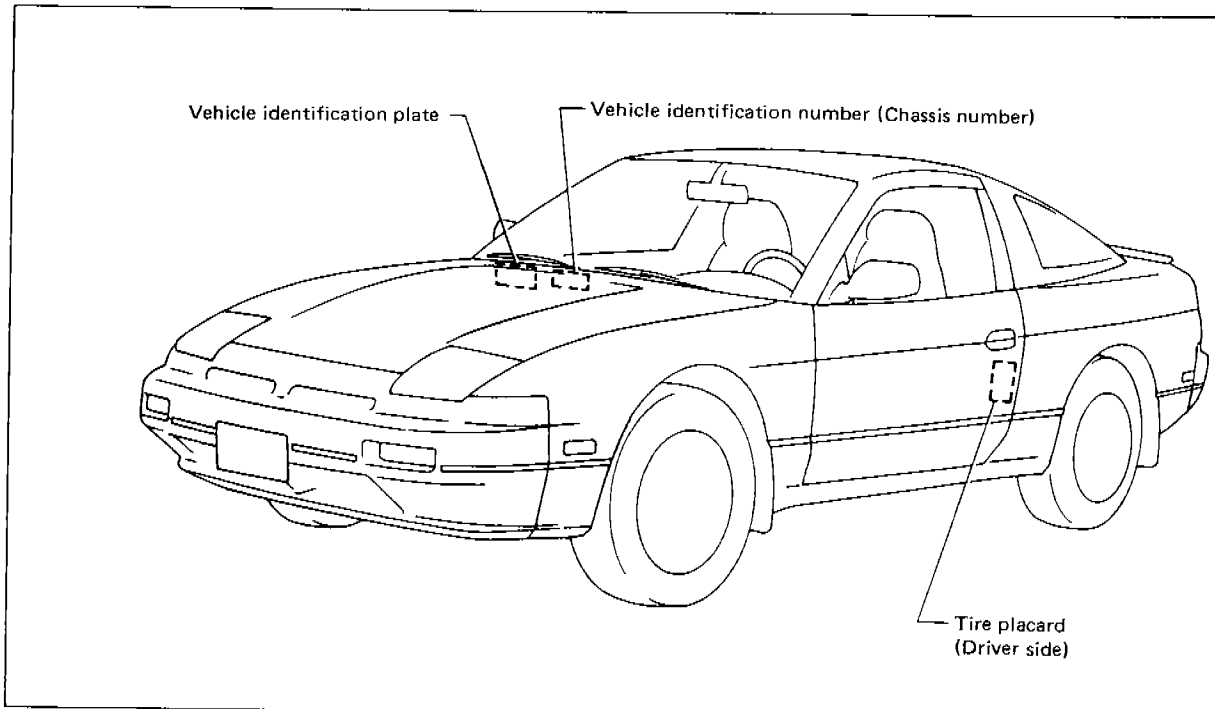

SG1554

VEHICLE IDENTIFICATION NUMBER (Chassis number)

Prefix and suffix designations
(For Europe)

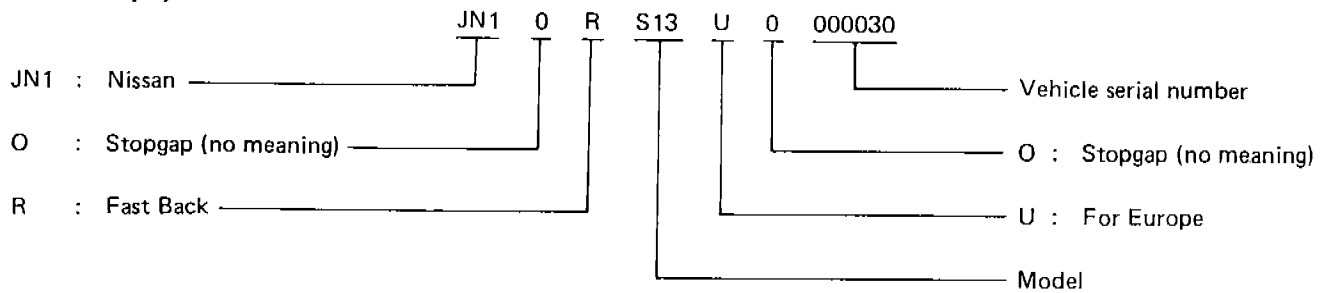

(Except for Europe)

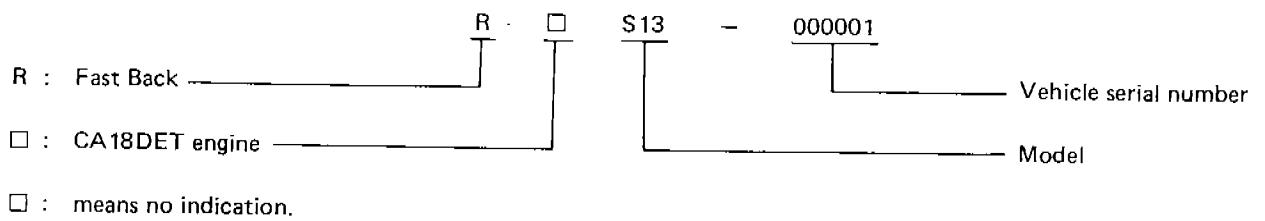

IDENTIFICATION INFORMATION

Identification Number (Cont'd)

IDENTIFICATION PLATE

| Europe | Except Europe | |
|-------------------------------------------|-------------------------------------------|------------------------------------------------------------------------------------------------------------------------------------------------------------------------------------------------------------------------------------------------------------------------------------------------------------------------------------------------------------------------------------------------------------------------------------------------------------------------------------------------------------------------------------------------------------|
| <p style="text-align: center;">SGI025</p> | <p style="text-align: center;">SGI316</p> | <ol style="list-style-type: none"> 1 Type approval number 2 Vehicle identification number (Chassis number) 3 Gross vehicle weight 4 Gross combination weight Gross vehicle weight + Gross trailing capacity (Weight) 5 Gross axle weight (Front) 6 Gross axle weight (Rear) 7 Type 8 Body color code 9 Trim color code 10 Model 11 Engine model 12 Engine displacement 13 Transmission model 14 Axle model |

ENGINE SERIAL NUMBER

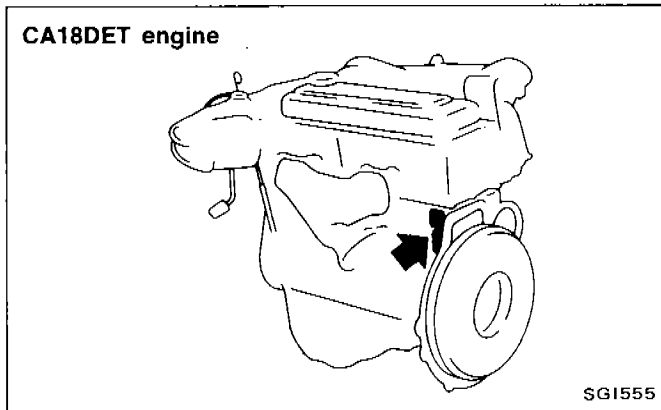

MANUAL TRANSMISSION NUMBER

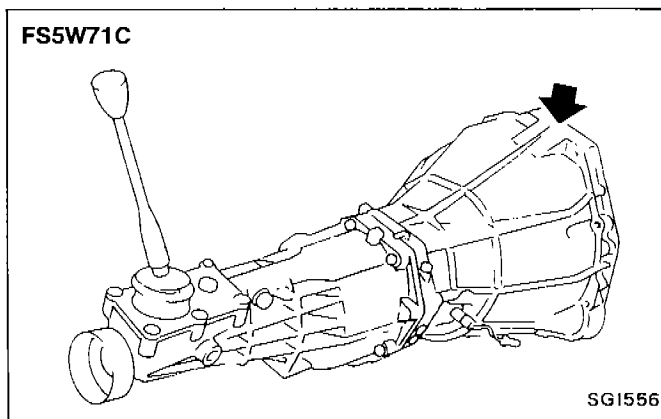

AUTOMATIC TRANSMISSION NUMBER

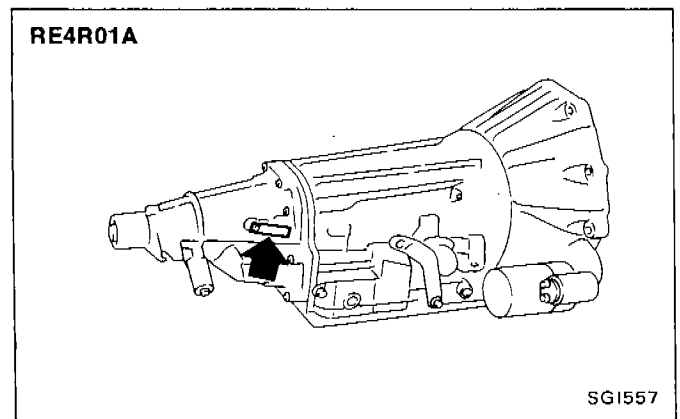

IDENTIFICATION INFORMATION

Dimensions

Unit: mm (in)

| | Europe | Except Europe |
|----------------|---------------|---------------|
| Overall length | 4,535 (178.5) | 4,520 (178.0) |
| Overall width | 1,690 (66.5) | 1,690 (66.5) |
| Overall height | 1,290 (50.8) | 1,290 (50.8) |
| Front tread | 1,465 (57.7) | 1,465 (57.7) |
| Rear tread | 1,465 (57.7) | 1,460 (57.5) |
| Wheelbase | 2,475 (97.4) | 2,475 (97.4) |

Wheels and Tires

| | | |
|------------|----------------|-----------------|
| Road wheel | Steel | 6-JJx15 |
| | Aluminum | 6-JJx15*1 |
| | Offset mm (in) | 40 (1.57) |
| Tire size | Conventional | 195/60R15 86H |
| | | 195/60R15 87V*2 |
| | Spare | T125/70D15*2 |

*1: Option

*2: Europe

LIFTING POINTS AND TOW TRUCK TOWING

Garage Jack and Safety Stand

WARNING:

- Never get under the vehicle while it is supported only by the jack. Always use safety stands to support the frame when you have to get under the vehicle.
- Place wheel chocks at the front wheels when the rear wheels are raised and place wheel chocks at the rear wheels when the front wheels are raised.

CAUTION:

Place a wooden or rubber block between safety stand and vehicle body when the supporting body is flat.

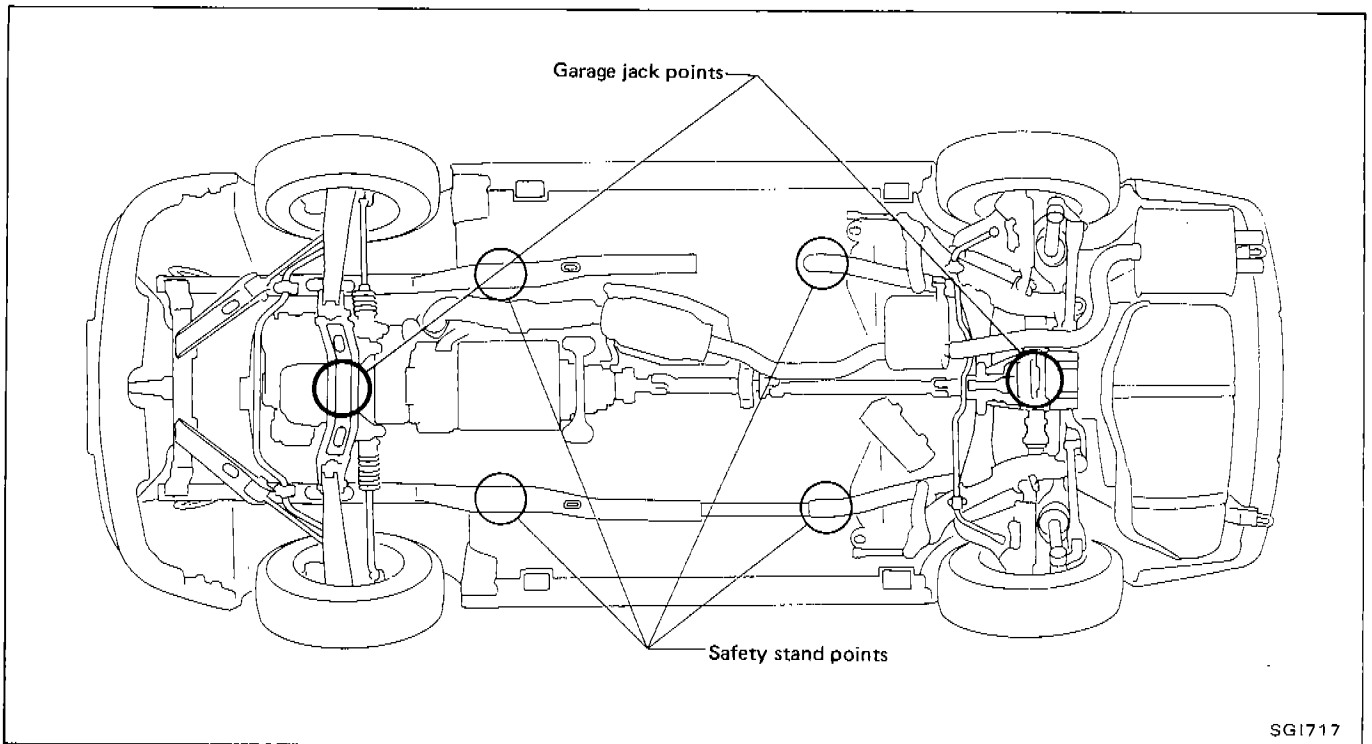

LIFTING POINTS AND TOW TRUCK TOWING

2-pole Lift

WARNING:

When lifting the vehicle, open the lift arms as wide as possible and ensure that the front and rear of the vehicle are well balanced.

When setting the lift arm, do not allow the arm to contact the brake tubes and fuel lines.

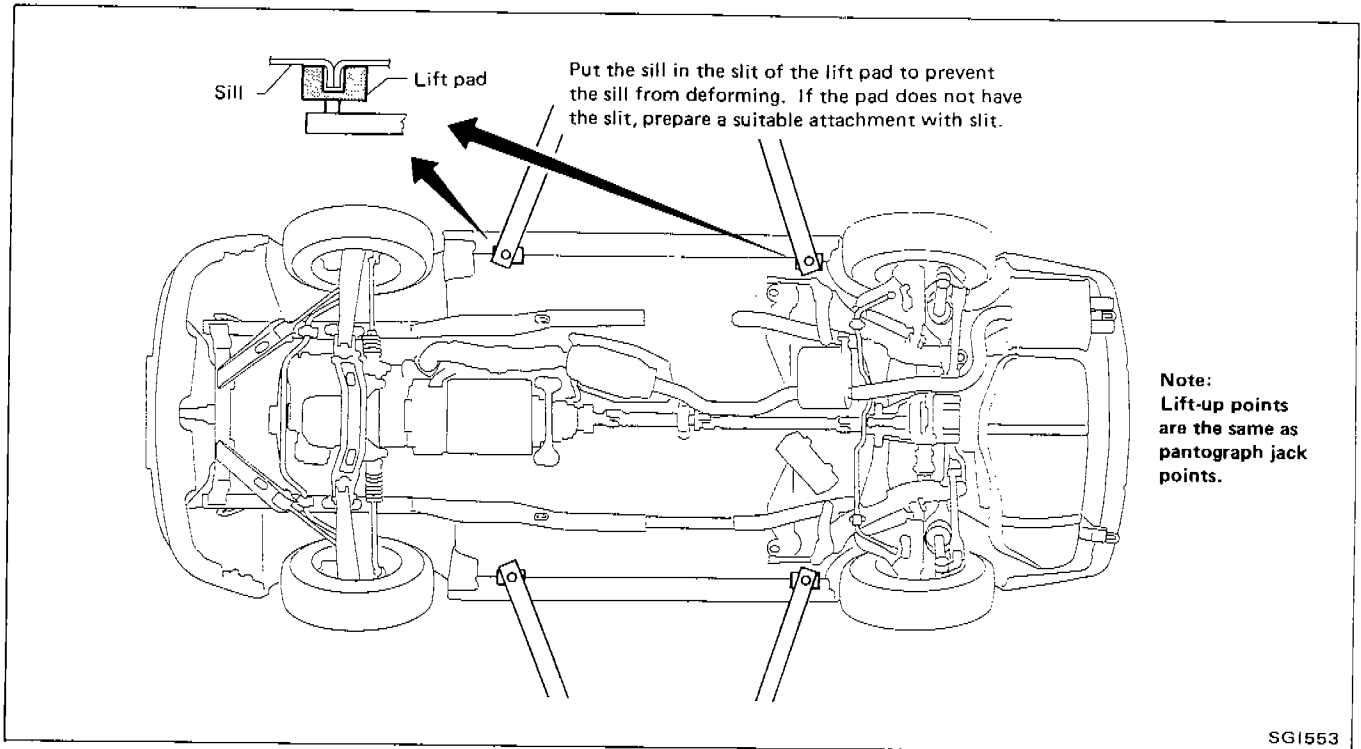

Tow Truck Towing

CAUTION:

- All applicable local laws regarding the towing operation must be obeyed.
- It is necessary to use proper towing equipment to avoid possible damage to the vehicle during a towing operation.
- When towing with the rear wheels on the ground, release the parking brake and move the gearshift lever to neutral ("N" position).

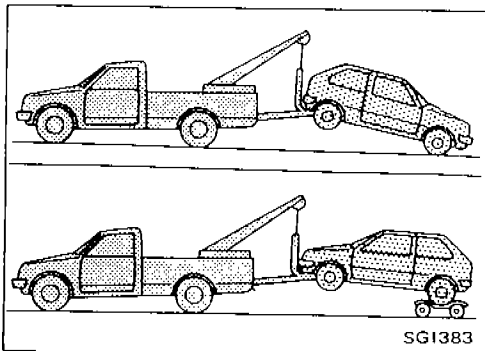

NISSAN recommends that vehicle be towed with the driving (rear) wheels off the ground as illustrated.

LIFTING POINTS AND TOW TRUCK TOWING

Tow Truck Towing (Cont'd)

TOWING AN AUTOMATIC TRANSMISSION MODEL WITH FOUR WHEELS ON GROUND OR TOWING WITH FRONT WHEELS RAISED (With rear wheels on ground)

Observe the following restricted towing speeds and distances.

Speed:

Below 50 km/h (30 MPH)

Distance:

Less than 65 km (40 miles)

If the speed or distance must necessarily be greater, remove the propeller shaft beforehand to prevent damage to the transmission.

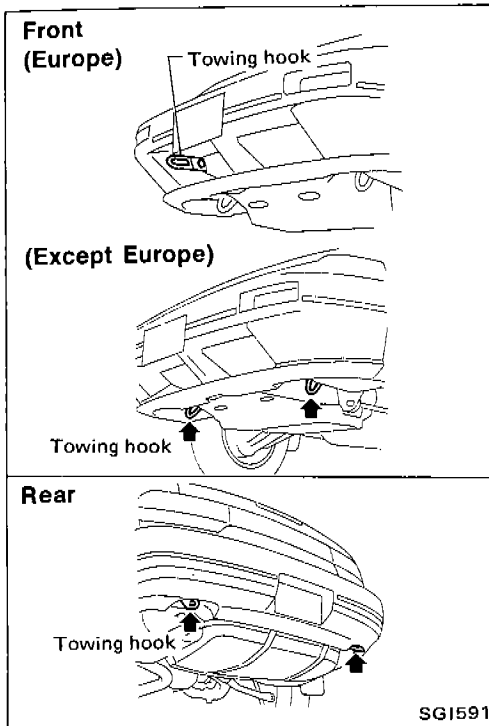

TOWING POINT

Always pull the cable straight out from the vehicle. Never pull on the hook at a sideways angle.

TIGHTENING TORQUE OF STANDARD BOLTS

| Grade | Bolt size | Bolt diameter* mm | Pitch mm | Tightening torque (Without lubricant) | | | | | |
|-------|-----------|-------------------|----------|---------------------------------------|------|-------|---------------------|------|-------|
| | | | | Hexagon head bolt | | | Hexagon flange bolt | | |
| | | | | N-m | kg-m | ft-lb | N-m | kg-m | ft-lb |
| 4T | M6 | 6.0 | 1.0 | 5.1 | 0.52 | 3.8 | 6.1 | 0.62 | 4.5 |
| | M8 | 8.0 | 1.25 | 13 | 1.3 | 9 | 15 | 1.5 | 11 |
| | | | 1.0 | 13 | 1.3 | 9 | 16 | 1.6 | 12 |
| | M10 | 10.0 | 1.5 | 25 | 2.5 | 18 | 29 | 3.0 | 22 |
| | | | 1.25 | 25 | 2.6 | 19 | 30 | 3.1 | 22 |
| | M12 | 12.0 | 1.75 | 42 | 4.3 | 31 | 51 | 5.2 | 38 |
| 1.25 | | | 46 | 4.7 | 34 | 56 | 5.7 | 41 | |
| M14 | 14.0 | 1.5 | 74 | 7.5 | 54 | 88 | 9.0 | 65 | |
| 7T | M6 | 6.0 | 1.0 | 8.4 | 0.86 | 6.2 | 10 | 1.0 | 7 |
| | M8 | 8.0 | 1.25 | 21 | 2.1 | 15 | 25 | 2.5 | 18 |
| | | | 1.0 | 22 | 2.2 | 16 | 26 | 2.7 | 20 |
| | M10 | 10.0 | 1.5 | 41 | 4.2 | 30 | 48 | 4.9 | 35 |
| | | | 1.25 | 43 | 4.4 | 32 | 51 | 5.2 | 38 |
| | M12 | 12.0 | 1.75 | 71 | 7.2 | 52 | 84 | 8.6 | 62 |
| 1.25 | | | 77 | 7.9 | 57 | 92 | 9.4 | 68 | |
| M14 | 14.0 | 1.5 | 127 | 13.0 | 94 | 147 | 15.0 | 108 | |
| 9T | M6 | 6.0 | 1.0 | 12 | 1.2 | 9 | 15 | 1.5 | 11 |
| | M8 | 8.0 | 1.25 | 29 | 3.0 | 22 | 35 | 3.6 | 26 |
| | | | 1.0 | 31 | 3.2 | 23 | 37 | 3.8 | 27 |
| | M10 | 10.0 | 1.5 | 59 | 6.0 | 43 | 70 | 7.1 | 51 |
| | | | 1.25 | 62 | 6.3 | 46 | 74 | 7.5 | 54 |
| | M12 | 12.0 | 1.75 | 98 | 10.0 | 72 | 118 | 12.0 | 87 |
| 1.25 | | | 108 | 11.0 | 80 | 137 | 14.0 | 101 | |
| M14 | 14.0 | 1.5 | 177 | 18.0 | 130 | 206 | 21.0 | 152 | |

- Special parts are excluded.
- This standard is applicable to bolts having the following marks embossed on the bolt head.

*: Nominal diameter

| Grade | Mark |
|----------|------|
| 4T | 4 |
| 7T | 7 |
| 9T | 9 |

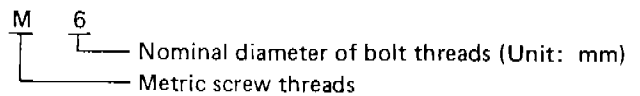

MAINTENANCE

SECTION **MA**

MA

CONTENTS

| | |
|-----------------------------------------------------|-------|
| PREPARATION | MA- 2 |
| PRE-DELIVERY INSPECTION ITEMS | MA- 3 |
| PERIODIC MAINTENANCE (Except for Europe) | MA- 4 |
| PERIODIC MAINTENANCE (For Europe except U.K.) | MA- 6 |
| PERIODIC MAINTENANCE (For U.K.) | MA- 8 |
| GENERAL MAINTENANCE | MA-10 |
| RECOMMENDED FLUIDS AND LUBRICANTS | MA-11 |
| ENGINE MAINTENANCE | MA-13 |
| CHASSIS AND BODY MAINTENANCE | MA-21 |
| SERVICE DATA AND SPECIFICATIONS (S.D.S.) | MA-29 |

PREPARATION

SPECIAL SERVICE TOOL

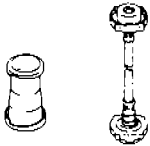
| Tool number Tool name | Description |
|----------------------------------------------|-----------------------------------------------------------------------------------|
| EG17650301 Radiator cap tester adapter |  |

COMMERCIAL SERVICE TOOL

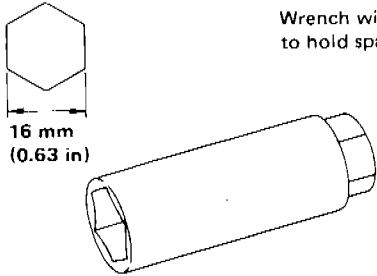
| Tool name | Description |
|-------------------|-------------------------------------------------------------------------------------------------------------------------------------------------------------------------------------------------------------------|
| Spark plug wrench |  <p data-bbox="874 801 1088 855">Wrench with a magnet to hold spark plug</p> <p data-bbox="1034 1086 1136 1115">SEM294A</p> |

PRE-DELIVERY INSPECTION ITEMS

Shown below are Pre-delivery Inspection Items required for the new vehicle. It is recommended that necessary items other than those listed here be added, paying due regard to the conditions in each country.

Perform applicable items on each model. Consult text of this section for specifications.

UNDER HOOD — engine off

- Radiator coolant level and coolant hose connections for leaks
- Battery fluid level, specific gravity and conditions of battery terminals
- Drive belts tension
- Fuel filter for water or dusts, and fuel lines and connections for leaks
- Engine oil level and oil leaks
- Clutch and brake reservoir fluid level and fluid lines for leaks
- Windshield and rear window washer and headlamp cleaner reservoir fluid level
- Power steering reservoir fluid level and hose connections for leaks

ON INSIDE AND OUTSIDE

- Remove front spring/strut spacer (If applicable)
- Operation of all instruments, gauges, lights and accessories
- Operation of horn(s), wiper and washer
- Steering lock for operation
- Check air conditioner for gas leaks
- Front and rear seats, and seat belts for operation
- All moldings, trims and fittings for fit and alignment
- All windows for operation and alignment
- Hood, trunk lid, door panels for fit and alignment
- Latches, keys and locks for operation
- Weatherstrips for adhesion and fit
- Headlamp aiming
- Tighten wheel nuts (Inc. inner nuts if applicable)
- Tire pressure (Inc. spare tire)
- Check front wheels for toe-in
- Install clock/voltmeter/room lamp fuse (If applicable)
- Install deodorizing filter to air purifier (If applicable)
- Remove wiper blade protectors (If applicable)

UNDER BODY

- Manual transmission/transaxle, transfer and differential gear oil level
- Brake and fuel lines and oil/fluid reservoirs for leaks
- Tighten bolts and nuts of steering linkage and gear box, suspension, propeller shafts and drive shafts
- Tighten rear body bolts and nuts (Models with wooden bed only)

ROAD TEST

- Clutch operation
- Parking brake operation
- Service brake operation
- Automatic transmission/transaxle shift timing and kickdown
- Steering control and returnability
- Engine performance
- Squeaks and rattles

ENGINE OPERATING AND HOT

- Adjust idle mixture and speed (and ignition timing* 1)
- Automatic transmission/transaxle fluid level
- Engine idling and stop knob operation (Diesel only)

FINAL INSPECTION

- Install necessary parts (outside mirror, wheel covers, seat belts, mat, carpet or mud flaps)
- Inspect for interior and exterior metal and paint damage
- Check for spare tire, jack, tools (wheel chock), and literature
- Wash, clean interior and exterior

*1: Not required on models with a direct ignition system

PERIODIC MAINTENANCE (Except for Europe)

The following tables show the normal maintenance schedule. Depending upon weather and atmospheric conditions, varying road surfaces, individual driving habits and vehicle usage, additional or more frequent maintenance will be required.

Periodic maintenance beyond the last period shown on the tables requires similar maintenance.

| MAINTENANCE OPERATION Perform either at number of kilometers (miles) or months, whichever comes first. | MAINTENANCE INTERVAL | | | | | | | | | Reference page | |
|------------------------------------------------------------------------------------------------------------------------------------------|----------------------|-------|------------------------------------------|------|------|------|------|------|------|----------------|----------------------------|
| | km x 1,000 | 1 | 10 | 20 | 30 | 40 | 50 | 60 | 70 | | 80 |
| | (Miles x 1,000) | (0.6) | (6) | (12) | (18) | (24) | (30) | (36) | (42) | | (48) |
| | Months | — | 6 | 12 | 18 | 24 | 30 | 36 | 42 | 48 | |
| ENGINE | | | | | | | | | | | |
| Underhood and under vehicle | | | | | | | | | | | |
| Check drive belts for cracks, fraying, wear & tension | | X | | X | | X | | X | | X | MA-13 |
| Change engine anti-freeze coolant (Ethylene glycol base) | | | | | | X | | | | X | MA-13 |
| Change engine coolant (Soft water) | | | X | X | X | X | X | X | X | X | MA-13 |
| Check cooling system | | | | X | | X | | X | | X | MA-14 |
| Check fuel lines | | | | | | X | | | | X | MA-15 |
| Replace air cleaner filter (Viscous paper type)* | | | | | | X | | | | X | MA-16 |
| Change engine oil (Use recommended oil)* | | | Every 5,000 km (3,000 miles) or 6 months | | | | | | | | MA-16 |
| Change engine oil filter* | | | X | X | X | X | X | X | X | X | MA-17 |
| Check & adjust mixture ratio (Check mixture ratio only on models bound for areas affected by emission regulations) | | X | X | X | X | X | X | X | X | X | EF & EC-25 |
| Replace fuel filter* | | | | | | X | | | | X | MA-16 |
| Check & replace spark plugs | Check | | X | | X | | X | | X | | MA-17 |
| | Replace | | | X | | X | | X | | X | MA-17 |
| Check positive crankcase ventilation (P.C.V.) system | | | | X | | X | | X | | X | MA-19 |
| Check vacuum fitting hoses & connections | | | | X | | X | | X | | X | MA-19 |
| Replace timing belt | | | Every 100,000 km (60,000 miles) | | | | | | | | EM-9 |
| CHASSIS AND BODY | | | | | | | | | | | |
| Underhood | | | | | | | | | | | |
| Check brake, clutch & automatic transmission fluid level & leaks* | | | X | X | X | X | X | X | X | X | MA-21, 22, 24 |
| Change brake fluid* | | | | | | X | | | | X | MA-24 |
| Check brake booster vacuum hoses, connections & check valve | | | | | | X | | | | X | MA-24 |
| Check power steering fluid & lines | | | X | X | X | X | X | X | X | X | MA-26 |
| Under vehicle | | | | | | | | | | | |
| Check brake, clutch & exhaust systems for proper attachment, leaks, cracks, chafing, abrasion, deterioration, etc. | | | X | X | X | X | X | X | X | X | MA-21, 24 |
| Check oil level in manual transmission & differential gear* | | | X | X | X | X | X | X | X | X | MA-21, 23 |
| Check steering gear & linkage, axle & suspension parts, propeller shaft & drive shafts for damaged, loose & missing parts & lubrication* | | X | | X | | X | | X | | X | MA-23, 26 FA-5, RA-5, 7 |
| Outside and inside | | | | | | | | | | | |
| Check wheel alignment. If necessary, rotate & balance wheels | | | | X | | X | | X | | X | MA-25, 26 FA-6 |
| Check brake pads, discs & other brake components for wear, deterioration & leaks* | | | X | X | X | X | X | X | X | X | MA-25 |
| Lubricate locks, hinges & hood latch* | | | X | X | X | X | X | X | X | X | MA-27 |
| Check seat belts, buckles, retractors, anchors & adjuster | | | | X | | X | | X | | X | MA-27 |
| Check foot brake, parking brake & clutch for free play, stroke & operation | | | X | X | X | X | X | X | X | X | CL-5, BR-7, 29 |

NOTE: Maintenance items with “*” should be performed more frequently according to “Maintenance under severe driving conditions”.

Check: Check. Correct or replace if necessary.

PERIODIC MAINTENANCE (Except for Europe)

MAINTENANCE UNDER SEVERE DRIVING CONDITIONS

The maintenance intervals shown on the preceding pages are for normal operating conditions. If the vehicle is mainly operated under severe driving conditions as shown below, more frequent maintenance must be performed on the following items as shown in the table.

Severe driving conditions

- A — Driving under dusty conditions
- B — Driving repeatedly short distances
- C — Towing a trailer
- D — Extensive idling
- E — Driving in extremely adverse weather conditions or in areas where ambient temperatures are either extremely low or extremely high
- F — Driving in high humidity areas or in mountainous areas
- G — Driving in areas using salt or other corrosive materials
- H — Driving on rough and/or muddy roads or in the desert
- I — Driving with frequent use of braking or in mountainous areas

| Driving condition | Maintenance item | Maintenance operation | Maintenance interval | Reference page |
|---------------------------------|------------------------------------------------------------------------------------|-----------------------|------------------------------------------------|----------------------------|
| A | Air cleaner filter | Replace | More frequently | MA-16 |
| A B C D | Engine oil | Replace | | MA-16 |
| A B C D | Engine oil filter | Replace | Every 5,000 km (3,000 miles) or 3 months | MA-17 |
| A E | Fuel filter | Replace | Every 20,000 km (12,000 miles) or 12 months | MA-16 |
| F | Brake fluid | Replace | | MA-24 |
| . . . C H | Automatic & manual transmission oil & differential gear oil | Replace | Every 40,000 km (24,000 miles) or 24 months | MA-22, 23 |
| G H | Steering gear & linkage, axle & suspension parts, propeller shaft & drive shaft | Check | Every 10,000 km (6,000 miles) or 6 months | MA-23, 26 FA-5, RA-5, 7 |
| A . . C G H I | Brake pads, discs & other brake components | Check | Every 5,000 km (3,000 miles) or 3 months | MA-25 |
| G | Lock, hinges & hood latch | Lubricate | | MA-27 |

Maintenance operation: Check = Check. Correct or replace if necessary.

PERIODIC MAINTENANCE (For Europe except U.K.)

The following tables show the normal maintenance schedule. Depending upon weather and atmospheric conditions, varying road surfaces, individual driving habits and vehicle usage, additional or more frequent maintenance will be required.

Periodic maintenance beyond the last period shown on the tables requires similar maintenance.

STANDARD & THE FIRST FREE SERVICES

| MAINTENANCE OPERATION | MAINTENANCE INTERVAL | | | | | | Reference page |
|-----------------------------------------------------------------------------------------------------------------------------------------------------------------|------------------------------------|-------|---------------------------------|----------|------|------|--------------------------------|
| | Months | — | 12 | 24 | 36 | 48 | |
| Perform the standard service on a yearly basis, but on a mileage basis when driving more than 20,000 km (12,000 miles) a year. | 1 | 0.6 | 20 | 40 | 60 | 80 | |
| | (Miles x 1,000) | (0.6) | (12) | (24) | (36) | (48) | |
| Engine | Underhood and under vehicle | | | | | | |
| Check drive belts for cracks, fraying, wear & tension | | | | X | | X | MA-13 |
| Change engine anti-freeze coolant (Ethylene glycol base) | | | | X | | X | MA-13 |
| Check cooling system | | X | X | X | X | X | MA-14 |
| Check fuel lines | | | | X | | X | MA-15 |
| Replace air cleaner filter (Viscous paper type)* | | | | X | | X | MA-16 |
| Replace timing belt | | | Every 100,000 km (60,000 miles) | | | | EM-9 |
| Check & adjust mixture ratio*1 | X*1 | | X | X | X | X | EF & EC-25 |
| Replace fuel filter* | | | | X | | X | MA-16 |
| Replace spark plugs | | | | | | | |
| Non-catalyzer models | | | X | X | X | X | MA-17 |
| Catalyzer models (Use PLATINUM-TIPPED type.) | | | Every 100,000 km (60,000 miles) | | | | MA-17 |
| Check positive crankcase ventilation (P.C.V.) system*1 | | | X | X | X | X | MA-19 |
| Check vacuum fitting hoses & connections*1 | | | X | X | X | X | MA-19 |
| Check exhaust gas sensor*2 | | | | X | | X | MA-20 |
| Check vapor lines*2 | | | | X | | X | MA-19 |
| Chassis and body | Underhood | | | | | | |
| Check brake & clutch fluid level & leaks | | | X | X | X | X | MA-21, 24 |
| Check automatic transmission fluid level & leaks* | | | | X | | X | MA-22 |
| Change brake fluid* | | | | X | | X | MA-24 |
| Check brake booster vacuum hoses, connections & check valve | | | | X | | X | MA-24 |
| Check power steering fluid & lines | | | X | X | X | X | MA-26 |
| | Under vehicle | | | | | | |
| Check brake & clutch for proper attachment, leaks, cracks, chafing, abrasion, deterioration, etc. | | | X | X | X | X | MA-21, 24 |
| Check oil level in manual transmission & differential gear* | | | | X | | X | MA-21, 23 |
| Check steering gear & linkage, axle & suspension parts, propeller shaft, drive shafts & exhaust system for damaged, loose & missing parts, lubrication & leaks* | X | | | X | | X | MA-21, 23, 26 FA-5, RA-5, 7 |
| | Outside and inside | | | | | | |
| Check wheel alignment. If necessary, rotate & balance wheels | | | X | X | X | X | MA-25, 26 FA-6 |
| Check brake pads, discs & other brake components for wear, deterioration & leaks* | | | X | X | X | X | MA-25 |
| Check seat belts, buckles, retractors, anchors & adjuster | | | | X | | X | MA-27 |
| Check foot brake, parking brake & clutch for free play, stroke & operation | | | X | X | X | X | CL-5, BR-7, 29 |
| Check body corrosion | | | | Annually | | | MA-28 |

NOTE: Maintenance items with "*" should be performed more frequently according to "Maintenance under severe driving conditions".

Check: Check. Correct or replace if necessary.

*1: Non-catalyzer models only

*2: Catalyzer models only

PERIODIC MAINTENANCE (For Europe except U.K.)

ENGINE OIL SERVICE

| MAINTENANCE OPERATION | MAINTENANCE INTERVAL | | | | | | | | | | Reference page |
|------------------------------------------------------------------|------------------------------------------|-------|-----|------|------|------|------|------|------|------|----------------|
| Perform at the specified time or mileage, whichever comes first. | Months | — | 6 | 12 | 18 | 24 | 30 | 36 | 42 | 48 | |
| | km x 1,000 | 1 | 10 | 20 | 30 | 40 | 50 | 60 | 70 | 80 | |
| | (Miles x 1,000) | (0.6) | (6) | (12) | (18) | (24) | (30) | (36) | (42) | (48) | |
| Underhood | | | | | | | | | | | |
| Change engine oil (Use recommended oil)* | Every 6 months or 5,000 km (3,000 miles) | | | | | | | | | | MA-16 |
| Change engine oil filter* | X | X | X | X | X | X | X | X | X | X | MA-17 |

NOTE: Maintenance items with “*” should be performed more frequently according to “Maintenance under severe driving conditions”.

MAINTENANCE UNDER SEVERE DRIVING CONDITIONS

The maintenance intervals shown on the preceding pages are for normal operating conditions. If the vehicle is mainly operated under severe driving conditions as shown below, more frequent maintenance must be performed on the following items as shown in the table.

Severe driving conditions

- A — Driving under dusty conditions
- B — Driving repeatedly short distances
- C — Towing a trailer
- D — Extensive idling
- E — Driving in extremely adverse weather conditions or in areas where ambient temperatures are either extremely low or extremely high
- F — Driving in high humidity areas or in mountainous areas
- G — Driving in areas using salt or other corrosive materials
- H — Driving on rough and/or muddy roads or in the desert
- I — Driving with frequent use of braking or in mountainous areas

| Driving condition | Maintenance item | Maintenance operation | Maintenance interval | Reference page |
|-----------------------------------------|--------------------------------------------------------------------------------------------------|-----------------------|------------------------------------------------|--------------------------------|
| Standard service | | | | |
| A | Air cleaner filter | Replace | | MA-16 |
| A E | Fuel filter | Replace | | MA-16 |
| F | Brake fluid | Replace | Every 12 months or 20,000 km (12,000 miles) | MA-24 |
| G H | Steering gear & linkage, axle & suspension parts, propeller shaft, drive shafts & exhaust system | Check | | MA-21, 23, 26 FA-5, RA-5, 7 |
| C H | Automatic & manual transmission oil, & differential gear oil | Replace | Every 24 months or 40,000 km (24,000 miles) | MA-22, 23 |
| A C G H I | Brake pads, discs & other brake components | Check | Every 6 months or 10,000 km (6,000 miles) | MA-25 |
| Engine oil service | | | | |
| A B C D | Engine oil | Replace | More frequently | MA-16 |
| A B C D | Engine oil filter | Replace | Every 3 months or 5,000 km (3,000 miles) | MA-17 |

Maintenance operation: Check = Check. Correct or replace if necessary.

PERIODIC MAINTENANCE (For U.K.)

The following tables show the normal maintenance schedule. Depending upon weather and atmospheric conditions, varying road surface, individual driving habits and vehicle usage, additional or more frequent maintenance will be required.

Periodic maintenance beyond the last period shown on the tables requires similar maintenance.

| MAINTENANCE OPERATION Perform either at number of miles (kilometers) or months, whichever comes first. | Miles x 1,000 (km x 1,000) Months | MAINTENANCE INTERVAL | | | | | | | | | | Reference page |
|-----------------------------------------------------------------------------------------------------------------------------------------------------------------|-----------------------------------------|------------------------------------------|------|------|------|------|------|------|-------|-------|----------|--------------------------------|
| | | 0.6 | 9 | 18 | 27 | 36 | 45 | 54 | 63 | 72 | | |
| | | (1) | (15) | (30) | (45) | (60) | (75) | (90) | (105) | (120) | | |
| | | — | 6 | 12 | 18 | 24 | 30 | 36 | 42 | 48 | | |
| ENGINE MAINTENANCE | | Under bonnet and under vehicle | | | | | | | | | | |
| Replace timing belt | | Every 60,000 miles (100,000 km) | | | | | | | | | | EM-9 |
| Change engine anti-freeze coolant (Ethylene glycol base) | | | | | | | X | | | | X | MA-13 |
| Check cooling system | | | | X | | X | | X | | X | | MA-14 |
| Check fuel lines | | | | | | | X | | | | X | MA-15 |
| Check drive belts for cracks, fraying, wear & tension | | X | | X | | X | | X | | X | | MA-13 |
| Replace air cleaner filter (Viscous paper type)* | | | | | | | X | | | | X | MA-16 |
| Change engine oil (Use recommended oil) & oil filter* | | Every 4,500 miles (7,500 km) or 6 months | | | | | | | | | | MA-16, 17 |
| Check & adjust mixture ratio | | X | X | X | X | X | X | X | X | X | X | EF & EC-25 |
| Replace fuel filter | | | | X | | X | | X | | | X | MA-16 |
| Replace spark plugs | | | X | X | X | X | X | X | X | X | X | MA-17 |
| Check positive crankcase ventilation (P.C.V.) system | | | | X | | X | | X | | X | | MA-19 |
| Check vacuum hose & connections | | | | X | | X | | X | | X | | MA-19 |
| CHASSIS AND BODY MAINTENANCE | | Under bonnet | | | | | | | | | | |
| Check brake & clutch fluid level & leaks* | | | X | X | X | X | X | X | X | X | X | MA-21, 24 |
| Check automatic transmission fluid level & leaks* | | | | X | | X | | X | | X | | MA-22 |
| Change brake fluid | | | | X | | X | | X | | X | | MA-24 |
| Check brake booster vacuum hoses, connections & check valve | | | | | | | X | | | | X | MA-24 |
| Check power steering fluid & lines | | | X | X | X | X | X | X | X | X | X | MA-26 |
| | | Under vehicle | | | | | | | | | | |
| Check brake & clutch for proper attachment, leaks, cracks, chafing, abrasion, deterioration, etc. | | | X | X | X | X | X | X | X | X | X | MA-21, 24 |
| Check oil level in manual transmission & differential gear* | | | | X | | X | | X | | X | | MA-21, 23 |
| Check steering gear & linkage, axle & suspension parts, propeller shaft, drive shafts & exhaust system for damaged, loose & missing parts, lubrication & leaks* | | X | | X | | X | | X | | X | | MA-21, 23, 26 FA-5, RA-5, 7 |
| | | Outside and inside | | | | | | | | | | |
| Check wheel alignment. If necessary, rotate & balance wheels | | | | X | | X | | X | | X | | MA-25, 26 FA-6 |
| Check brake pads, disc & other brake components for wear, deterioration & leaks* | | | X | X | X | X | X | X | X | X | X | MA-25 |
| Check seat belts, buckles, retractors & adjuster | | | | X | | X | | X | | X | | MA-27 |
| Check foot brake, hand brake & clutch for free play, stroke & operation | | | X | X | X | X | X | X | X | X | X | CL-5, BR-7, 29 |
| Check body corrosion | | | | | | | | | | | Annually | MA-28 |

NOTE: Maintenance items with “*” should be performed more frequently according to “Maintenance under severe driving conditions”.

Check: Check. Correct or replace if necessary.

PERIODIC MAINTENANCE (For U.K.)

MAINTENANCE UNDER SEVERE DRIVING CONDITIONS

The maintenance intervals shown on the preceding pages are for normal operating conditions. If the vehicle is mainly operated under severe driving conditions as shown below, more frequent maintenance must be performed on the following items as shown in the table.

Severe driving conditions

- A — Driving under dusty conditions
- B — Driving repeatedly short distances
- C — Towing a trailer
- D — Extensive idling
- E — Driving in areas using salt or other corrosive materials
- F — Driving on rough and/or muddy roads or in the desert
- G — Driving with frequent use of braking or in mountainous areas

| Driving condition | Maintenance item | Maintenance operation | Maintenance interval | Reference page |
|-------------------|--------------------------------------------------------------------------------------------------|-----------------------|---------------------------------------------|--------------------------------|
| A | Air cleaner filter | Replace | | MA-16 |
| A B C D . . . | Engine oil & oil filter | Replace | More frequently | MA-16, 17 |
| . . C . . F . | Automatic & manual transmission oil, differential gear oil | Replace | Every 36,000 miles (60,000 km) or 24 months | MA-22, 23 |
| E F . | Steering gear & linkage, axle & suspension parts, propeller shaft, drive shafts & exhaust system | Check | Every 9,000 miles (15,000 km) or 6 months | MA-21, 23, 26 FA-5, RA-5, 7 |
| A . C . E F G | Brake pads, discs & other brake components | Check | Every 4,500 miles (7,500 km) or 3 months | MA-25 |

Maintenance operation: Check = Check. Correct or replace if necessary

GENERAL MAINTENANCE

General maintenance includes those items which should be checked during the normal day-to-day operation of the vehicle. They are essential if the vehicle is to continue operating properly. The owners can perform the checks and inspections themselves or they can have their NISSAN dealers do them for a nominal charge.

| Item | Reference pages |
|------------------------------------------------------------------------------------------------------------------------------------------------------------------------------------------------------------------------------------------------------------------------------------------------------------------------------------------------------------------------------------------------|-----------------|
| OUTSIDE THE VEHICLE | |
| The maintenance items listed here should be performed from time to time, unless otherwise specified. | |
| Tires Check the pressure with a gauge periodically when at a service station, including the spare, and adjust to the specified pressure if necessary. Check carefully for damage, cuts or excessive wear. | — |
| Windshield wiper blades Check for cracks or wear if they do not wipe properly. | — |
| Doors and engine hood Check that all doors, the engine hood, the trunk lid and back door operate properly. Also ensure that all latches lock securely. Lubricate if necessary. Make sure that the secondary latch keeps the hood from opening when the primary latch is released. When driving in areas using road salt or other corrosive materials, check for lubrication frequently. | MA-27 |
| Tire rotation Tires should be rotated every 10,000 km (6,000 miles). | MA-26 |
| INSIDE THE VEHICLE | |
| The maintenance items listed here should be checked on a regular basis, such as when performing periodic maintenance, cleaning the vehicle etc. | |
| Lights Make sure that the headlights, stop lights, tail lights, turn signal lights, and other lights are all operating properly and installed securely. Also check headlight aim. | — |
| Warning lights and chimes Make sure that all warning lights and chimes are operating properly. | — |
| Steering wheel Check for change in the steering conditions, such as excessive free play, hard steering or strange noises. Free play: Less than 35 mm (1.38 in) | — |
| UNDER THE HOOD AND VEHICLE | |
| The maintenance items listed here should be checked periodically e.g. each time you check the engine oil or refuel. | |
| Windshield washer fluid Check that there is adequate fluid in the tank. | — |
| Engine coolant level Check the coolant level when the engine is cold. | MA-13 |
| Engine oil level Check the level after parking the vehicle on a level spot and turning off the engine. | MA-16 |
| Brake and clutch fluid level Make sure that the brake and clutch fluid level is between the "MAX" and "MIN" lines on the reservoir. | MA-21, 24 |
| Battery Check the fluid level in each cell. It should be between the "MAX" and "MIN" lines. | — |

RECOMMENDED FLUIDS AND LUBRICANTS

Fluids and Lubricants

| | Capacity (Approximate) | | Recommended fluids and lubricants |
|--------------------------------------|------------------------|-------------|-------------------------------------------------------------|
| | Liter | Imp measure | |
| Engine oil (Refill) | | | |
| With oil filter | 3.5 | 3-1/8 qt | API SF/CC, SF/CD, SE or SG* |
| Without oil filter | 3.1 | 2-3/4 qt | |
| Cooling system (With reservoir tank) | 7.0 | 6-1/8 qt | Anti-freeze coolant (Ethylene glycol base) or soft water |
| Manual transmission gear oil | 2.4 | 4-1/4 pt | API GL-4* |
| Differential carrier gear oil | 1.8 | 3-1/8 pt | API GL-5* |
| Automatic transmission fluid | 7.9 | 7 qt | Type DEXRON™ |
| Power steering fluid | 0.9 | 3/4 qt | |
| Brake and clutch fluid | — | — | DOT 3 (US FMVSS No. 116) |
| Multi-purpose grease | — | — | NLGI No. 2 (Lithium soap base) |

* For further details, see "SAE Viscosity Number".

RECOMMENDED FLUIDS AND LUBRICANTS

SAE Viscosity Number

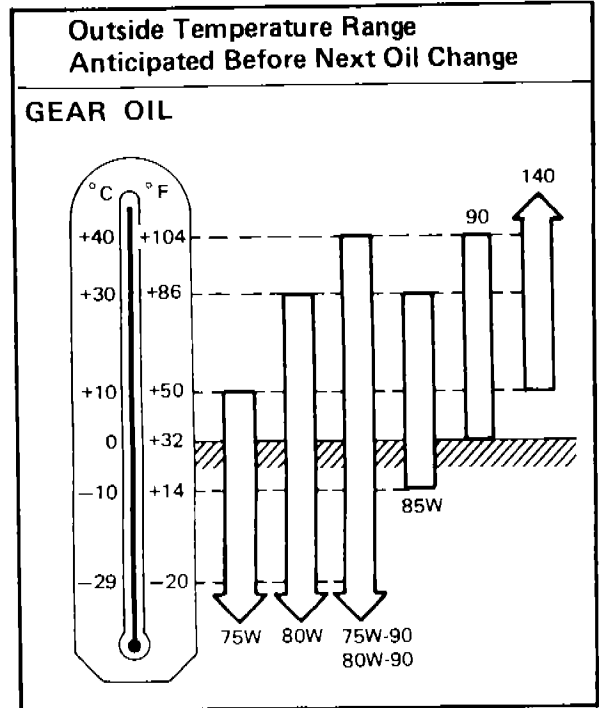
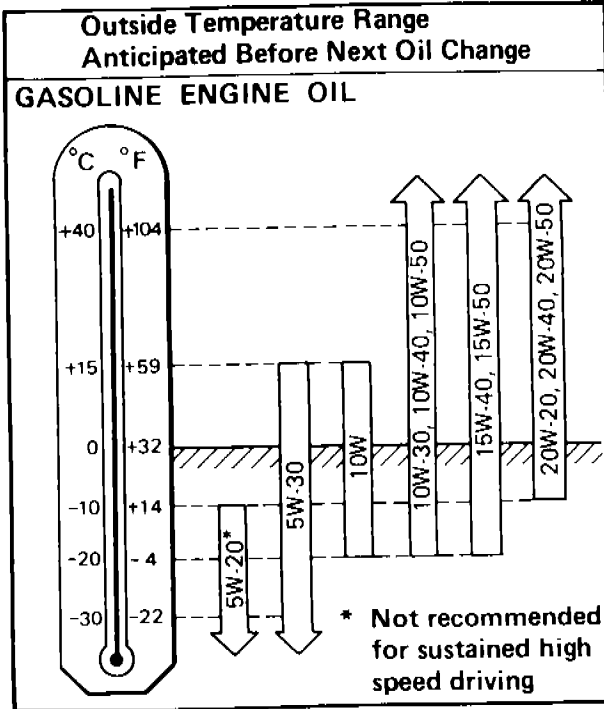

- For warm and cold areas: 10W-30 is preferable for ambient temperatures above -20°C (-4°F).
- For hot areas: 20W-40 and 20W-50 are suitable.
- For turbo engines: 5W-20 is not recommended. 5W-30 should be used only under extremely cold conditions.

- For warm and cold areas: 75W-90 for transmission and 80W-90 for differential carrier are preferable.
- For hot areas: 90 is suitable for ambient temperatures below 40°C (104°F).

ENGINE MAINTENANCE

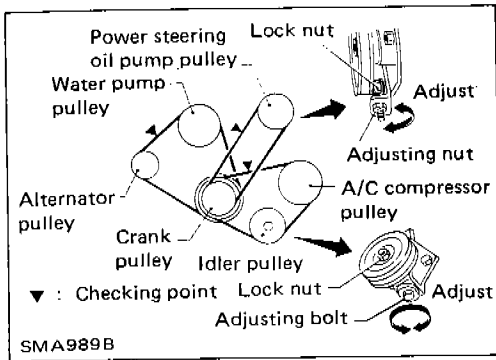

Checking Drive Belts

1. Inspect for cracks, fraying, wear or oil adhesion. If necessary, replace with a new one.
2. Inspect drive belt deflections by pushing on the belt midway between pulleys.

Adjust if belt deflections exceed the limit.

Belt deflection:

Unit: mm (in)

| | Used belt deflection | | Set deflection of new belt |
|----------------------------|----------------------|------------------------------|----------------------------|
| | Limit | Adjusted deflection | |
| Alternator | 8 (0.31) | 4.5 - 5.5 (0.177 - 0.217) | 4 - 5 (0.16 - 0.20) |
| Air conditioner compressor | 12 (0.47) | 7 - 9 (0.28 - 0.35) | 6 - 8 (0.24 - 0.31) |
| Power steering oil pump | 15 (0.59) | 10 - 12 (0.39 - 0.47) | 9 - 11 (0.35 - 0.43) |
| Applied pushing force | 98 N (10 kg, 22 lb) | | |

Inspect drive belt deflections when engine is cold.

Changing Engine Coolant

WARNING:

To avoid being scalded, never change the coolant when the engine is hot.

1. Move heater "TEMP" control lever all the way to "HOT" position.
2. Open drain cock at the bottom of radiator, and remove radiator cap.
 - **Be careful not to allow coolant to contact drive belts.**
3. Remove cylinder block drain plug.
4. Close drain cock and tighten drain plug securely.
5. Fill radiator with water and warm up engine.
6. Stop engine and wait until it cools down.
7. Repeat step 2 through step 6 until clear water begins to drain from radiator.
8. Drain water.
 - **Apply sealant to the thread of drain plug.**
 ⚙: 54 - 74 N·m (5.5 - 7.5 kg·m, 40 - 54 ft·lb)

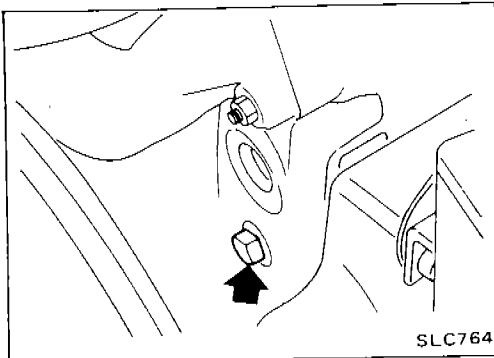
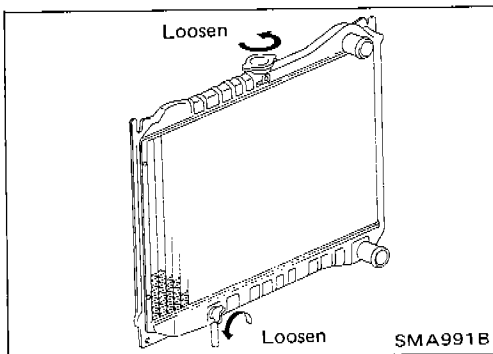
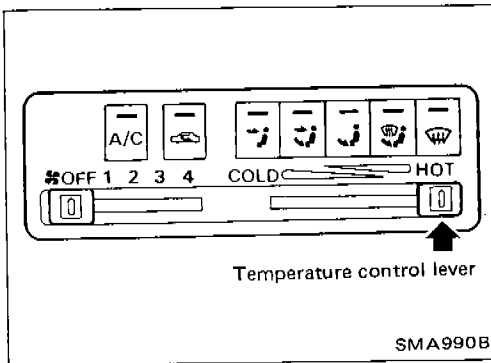

ENGINE MAINTENANCE

Changing Engine Coolant (Cont'd)

9. Fill radiator with coolant up to specified level.
Follow instructions attached to anti-freeze container for mixing ratio of anti-freeze to water.

Coolant capacity (With reservoir tank):

7.0 ℓ (6-1/8 Imp qt)

Pour coolant through coolant filler neck slowly to allow air in system to escape.

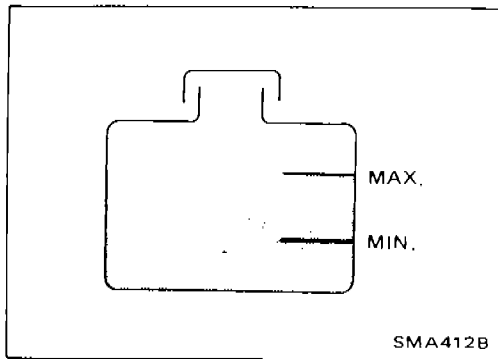
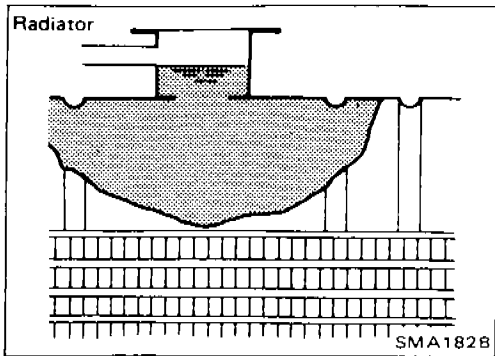

10. Remove reservoir tank, drain coolant, then clean reservoir tank.
11. Fill reservoir tank with coolant up to "MAX" level.
12. Run engine and warm it up.
13. Stop engine and cool it down, then add coolant as necessary.

Checking Cooling System

CHECKING HOSES

Check hoses for improper attachment and for leaks, cracks, damage, loose connections, chafing and deterioration.

CHECKING RADIATOR CAP

Apply pressure to radiator cap with cap tester to see if it is satisfactory.

Radiator cap relief pressure:

78 - 98 kPa

(0.78 - 0.98 bar, 0.8 - 1.0 kg/cm², 11 - 14 psi)

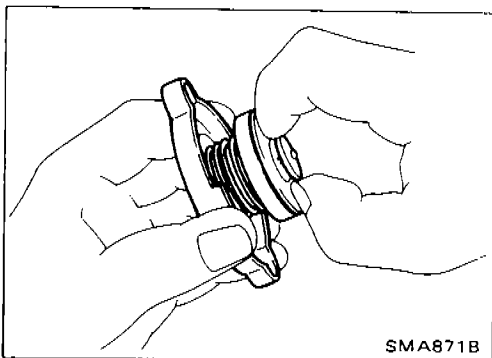
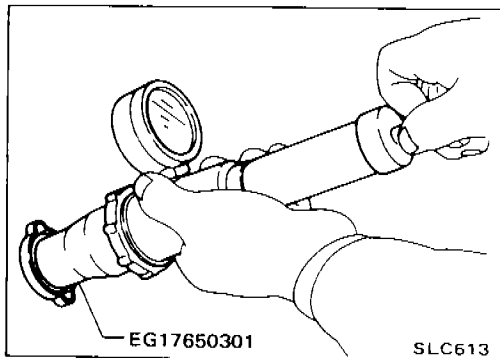

Pull the negative-pressure valve to open it. Check that it closes completely when released.

ENGINE MAINTENANCE

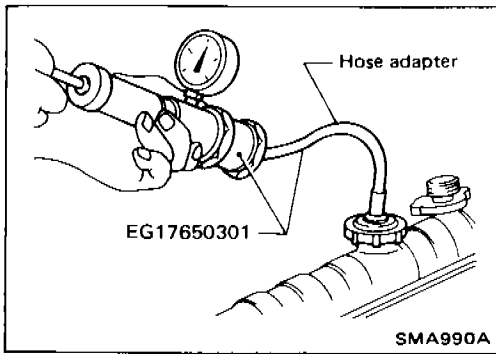

Checking Cooling System (Cont'd) CHECKING COOLING SYSTEM FOR LEAKS

Apply pressure to the cooling system with cap tester to check for leakage.

Testing pressure:

98 kPa (0.98 bar, 1.0 kg/cm², 14 psi)

CAUTION:

Higher pressure than the specified value may cause damage to radiator.

Checking Fuel Lines

Inspect fuel lines and tank for improper attachment and for leaks, cracks, damage, loose connections, chafing and deterioration.

If necessary, repair or replace faulty parts.

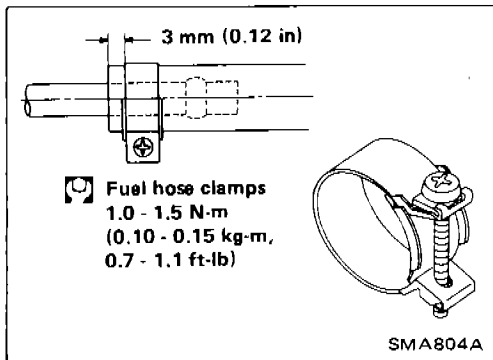

CAUTION:

Tighten high-pressure rubber hose clamp so that clamp end is 3 mm (0.12 in) from hose end.

Tightening torque specifications are the same for all rubber hose clamps.

Ensure that screw does not contact adjacent parts.

Changing Fuel Filter

WARNING:

Before removing fuel filter, release fuel pressure from fuel line to eliminate danger.

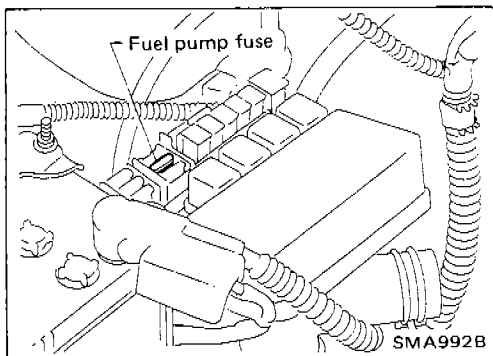

1. Remove fuse for fuel pump.
2. Start engine.
3. After engine stalls, crank engine two or three times to make sure that fuel pressure is released.
4. Turn ignition switch off and install fuse for fuel pump.

ENGINE MAINTENANCE

Changing Fuel Filter (Cont'd)

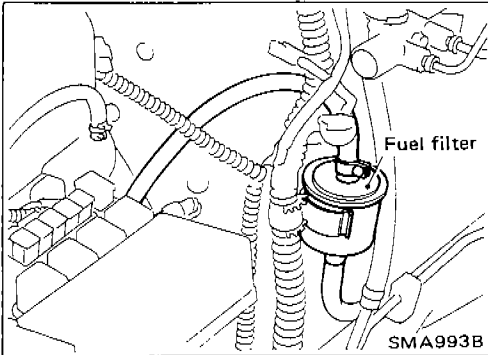

5. Loosen fuel hose clamps.

6. Replace fuel filter.

- Be careful not to spill fuel over engine compartment. Place a shop towel to absorb fuel.
- Use a high-pressure type fuel filter. Do not use a synthetic resinous fuel filter.
- When tightening fuel hose clamps, refer to "Checking Fuel Lines".

Changing Air Cleaner Filter

Viscous paper type

The viscous paper type filter does not need cleaning between renewals.

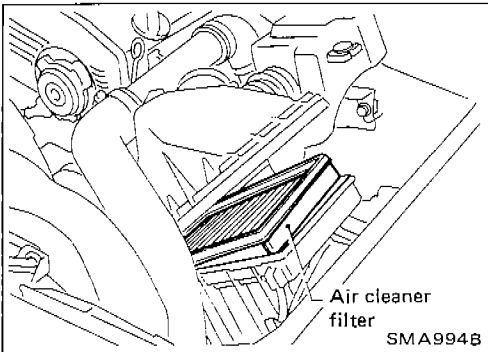

Changing Engine Oil

WARNING:

Be careful not to burn yourself, as the engine oil is hot.

1. Warm up engine, and check for oil leakage from engine components.
2. Remove drain plug and oil filler cap.
3. Drain oil and refill with new engine oil.

Refill oil capacity (Approximate):

With oil filter change

3.5 ℓ (3-1/8 Imp qt)

Without oil filter change

3.1 ℓ (2-3/4 Imp qt)

CAUTION:

- Be sure to clean drain plug and install with new washer.
Drain plug:
⌘: 29 - 39 N·m (3.0 - 4.0 kg-m, 22 - 29 ft-lb)
- Use recommended engine oil.

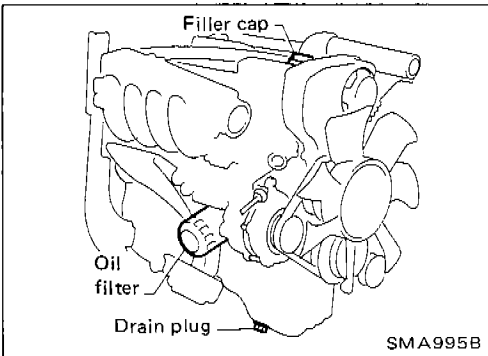

ENGINE MAINTENANCE

Changing Engine Oil (Cont'd)

4. Check oil level.
5. Start engine and check area around drain plug and oil filter for oil leakage.
6. Run engine for a few minutes, then turn it off. After several minutes, check oil level.

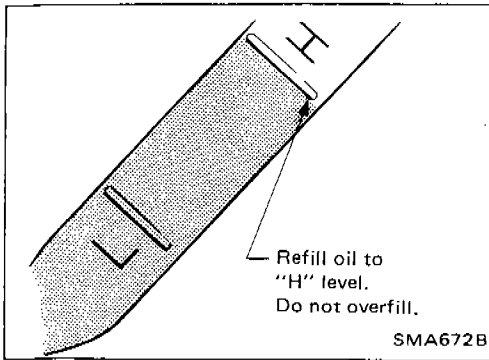

Changing Oil Filter

1. Remove oil filter.

WARNING:

Be careful not to burn yourself, as the engine and the engine oil are hot.

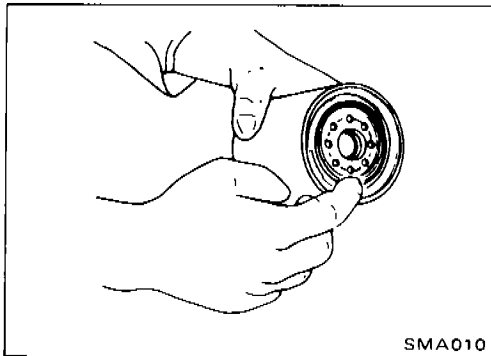

2. Before installing new oil filter, clean the oil filter mounting surface on cylinder block, and coat the rubber seal of oil filter with a little engine oil.

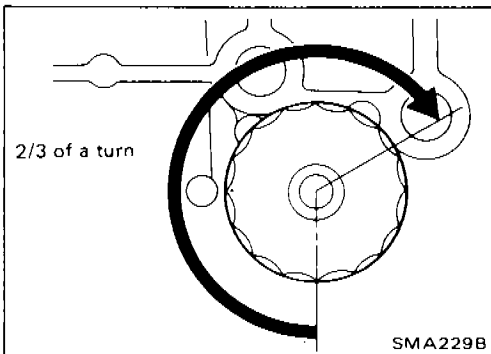

3. Screw in the oil filter until a slight resistance is felt, then tighten additionally more than 2/3 turn.

4. Add engine oil.

Refer to "Changing Engine Oil".

Checking and Changing Spark Plugs

1. Remove ornament cover.

ENGINE MAINTENANCE

Checking and Changing Spark Plugs (Cont'd)

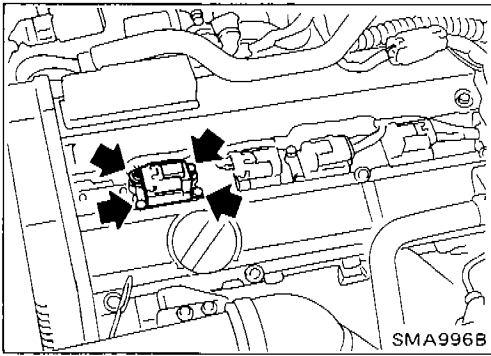

2. Disconnect harness connector between ignition coil and power transistor.
3. Remove ignition coil bracket fixing bolts and pull out this bracket with ignition coils.

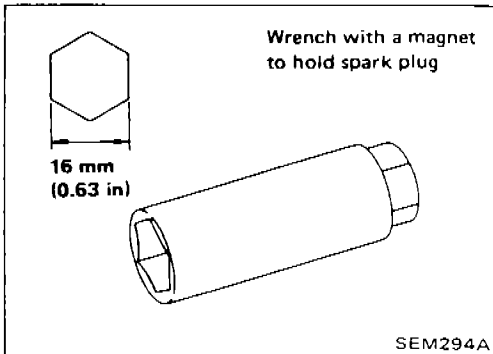

4. Remove spark plugs with suitable spark plug wrench.

— For model with catalyzer —

Spark plug (Platinum-tipped type):

Standard type PFR6A-11

Hot type PFR5A-11

Cold type PFR7A-11

⚙: 20 - 29 N·m (2.0 - 3.0 kg·m, 14 - 22 ft·lb)

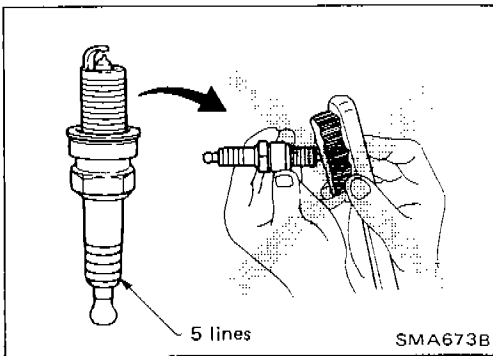

- Checking and adjusting plug gap are not required between renewals.
- Never use a wire brush for cleaning.
- If plug tip is covered with carbon, spark plug cleaner can be used.

Cleaner air pressure:

Less than 588 kPa

(5.9 bar, 6 kg/cm², 85 psi)

Cleaning time:

Less than 20 seconds

— For model without catalyzer —

Spark plug (Conventional type):

Standard type BCPR6ES-11

Hot type BCPR5ES-11

Cold type BCPR7ES-11

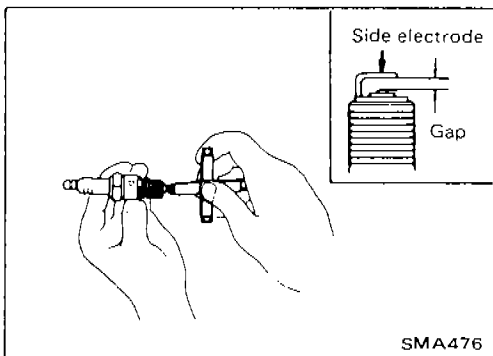

When using conventional type spark plugs, check spark plug gap. (Non-catalyzer models only)

Gap:

1.0 - 1.1 mm (0.039 - 0.043 in)

Spark plug:

⚙: 20 - 29 N·m (2.0 - 3.0 kg·m, 14 - 22 ft·lb)

ENGINE MAINTENANCE

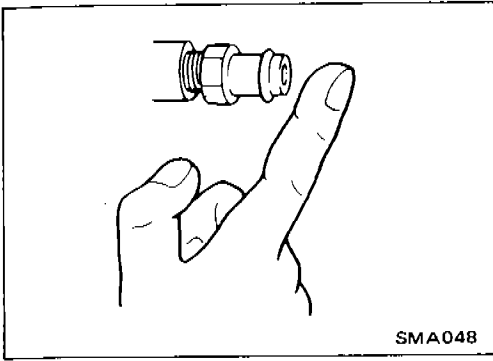

Checking Positive Crankcase Ventilation (P.C.V.) System

CHECKING P.C.V. VALVE

With engine running at idle, remove ventilation hose from P.C.V. valve; if valve is working properly, a hissing noise will be heard as air passes through it and a strong vacuum should be felt immediately when a finger is placed over valve inlet.

Checking Vacuum Hoses and Connections

Check vacuum hoses for improper attachment and for leaks, cracks, damage, loose connections, chafing and deterioration.

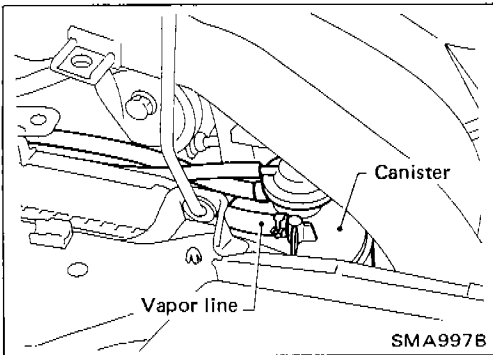

Checking Vapor Lines

1. Visually inspect vapor lines for improper attachment and for cracks, damage, loose connections, chafing and deterioration.
2. Inspect vacuum relief valve of fuel tank filler cap for clogging, sticking, etc.

Refer to "EVAPORATIVE EMISSION CONTROL SYSTEM" in EF & EC section.

CHASSIS AND BODY MAINTENANCE

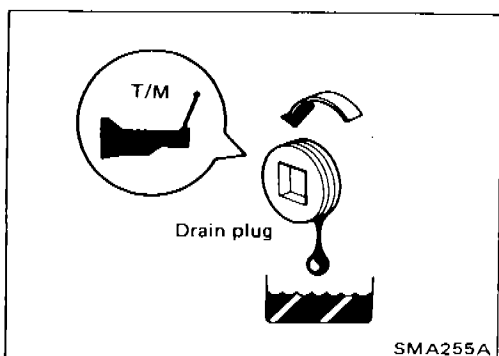

Changing M/T Oil

1. Drain oil and refill with new gear oil.
2. Check oil level.

Oil capacity:

2.4 ℓ (4-1/4 Imp pt)

Drain plug:

⌘: 25 - 34 N·m (2.5 - 3.5 kg·m, 18 - 25 ft·lb)

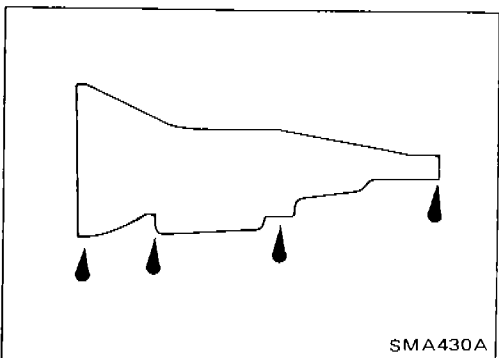

Checking A/T Fluid

1. Check for fluid leakage.

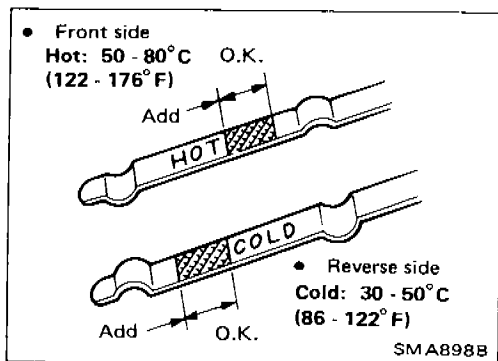

2. Check fluid level.

Fluid level should be checked using "HOT" range on dipstick at fluid temperatures of 50 to 80°C (122 to 176°F) after vehicle has been driven approximately 5 minutes in urban areas after engine is warmed up. But it can be checked at fluid temperatures of 30 to 50°C (86 to 122°F) using "COLD" range on dipstick for reference after engine is warmed up and before driving. However, fluid level must be rechecked using "HOT" range.

- 1) Park vehicle on level surface and set parking brake.
- 2) Start engine and then move selector lever through each gear range, ending in "P".
- 3) Check fluid level with engine idling.
- 4) Remove dipstick and wipe it clean with lint-free paper.
- 5) Reinsert dipstick into charging pipe as far as it will go.
- 6) Remove dipstick and note reading. If level is at low side of either range, add fluid to the charging pipe.

Do not overfill.

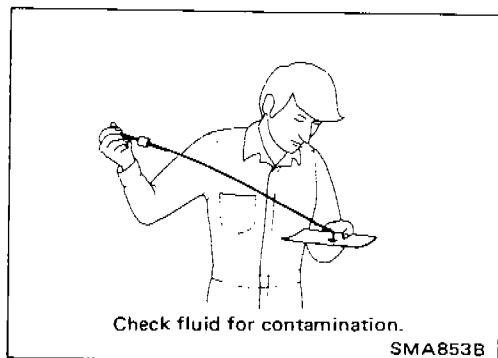

3. Check fluid condition.

Check fluid for contamination. If fluid is very dark or smells burned, or contains frictional material (clutches, band, etc.), check operation of A/T.

Refer to section AT for checking operation of A/T.

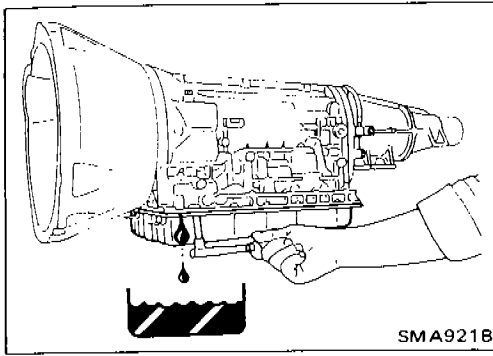

Changing A/T Fluid

1. Drain fluid by removing oil pan.
2. Replace gasket with new one.
3. Refill with fluid and then check fluid level.

Oil capacity (With torque converter):
7.9 ℓ (7 Imp qt)

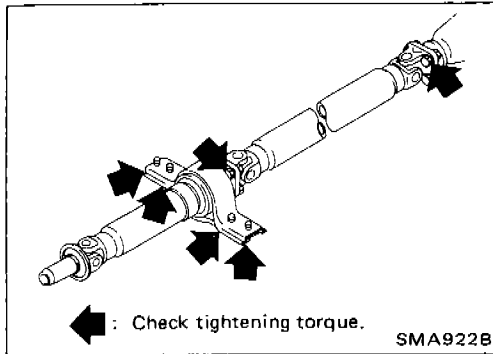

Checking Propeller Shaft

Check propeller shaft and center bearing for damage, looseness or grease leakage.

If greasing points are provided, supply grease as necessary.
Refer to section PD.

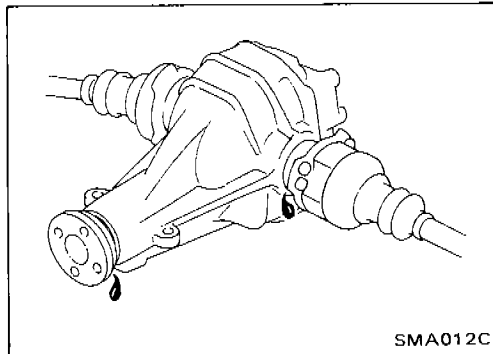

Checking Differential Gear Oil

1. Check differential carrier for oil leakage.

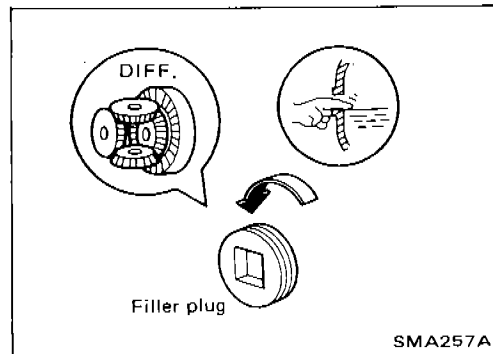

2. Check oil level.

Filler plug:

⌘: 59 - 98 N·m (6 - 10 kg·m, 43 - 72 ft·lb)

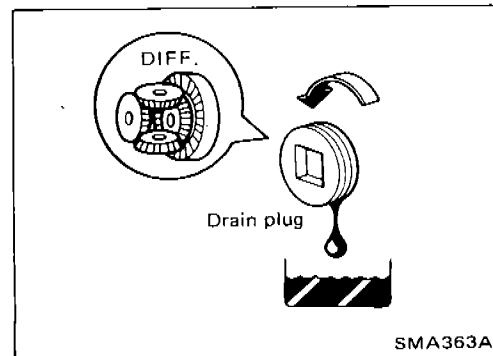

Changing Differential Gear Oil

1. Drain oil and refill with new gear oil.
2. Check oil level.

Oil capacity:

1.8 ℓ (3-1/8 Imp pt)

Drain plug:

⌘: 59 - 98 N·m (6 - 10 kg·m, 43 - 72 ft·lb)

CHASSIS AND BODY MAINTENANCE

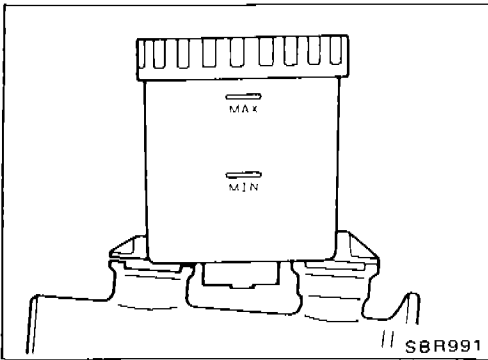

Checking Brake Fluid Level and Leaks

- If fluid level is extremely low, check brake system for leaks.

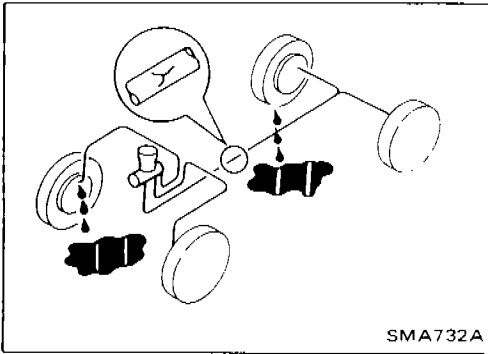

Checking Brake System

- Check brake fluid lines and parking brake cables for improper attachment and for leaks, chafing, abrasions, deterioration, etc.

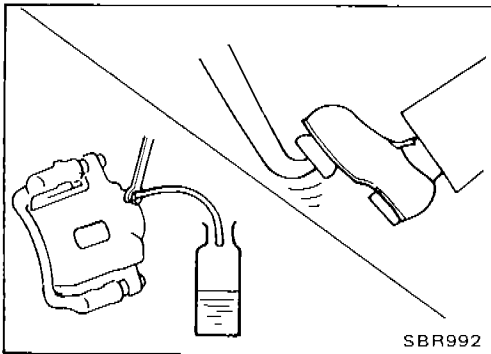

Changing Brake Fluid

1. Drain brake fluid from each air bleeder valve.
2. Refill until new brake fluid comes out from each air bleeder valve.

Use same procedure as in bleeding hydraulic system to refill brake fluid.

Refer to section BR.

- Refill with recommended brake fluid "DOT 3".
- Never reuse drained brake fluid.
- Be careful not to splash brake fluid on painted areas.

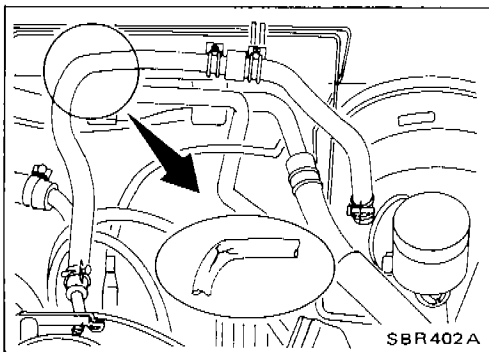

Checking Brake Booster, Vacuum Hoses, Connections and Check Valve

Check vacuum lines, connections and check valve for improper attachment, air tightness, chafing and deterioration.

CHASSIS AND BODY MAINTENANCE

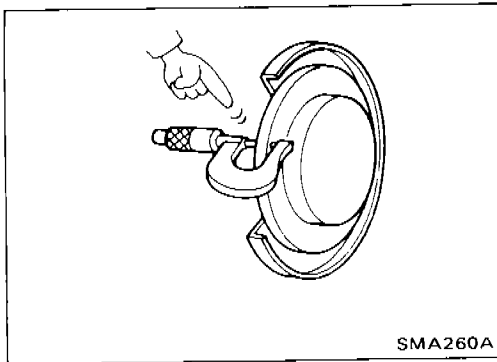

Checking Disc Brake

- Check condition of disc brake components.

ROTOR

- Check condition and thickness.

Unit: mm (in)

| | Front | | Rear | |
|--------------------|---------------|--------------|---------------|--------|
| | Except Europe | Europe | Except Europe | Europe |
| Disc brake type | CL18VB | CL25VA | CL9H | AD9 |
| Standard thickness | 18.0 (0.709) | 22.0 (0.866) | 9.0 (0.354) | |
| Minimum thickness | 16.0 (0.630) | 20.0 (0.787) | 8.0 (0.315) | |

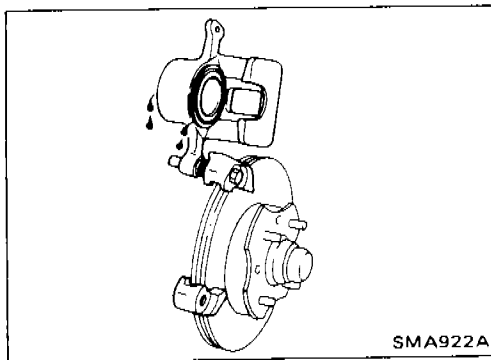

CALIPER

- Check operation and for leakage.

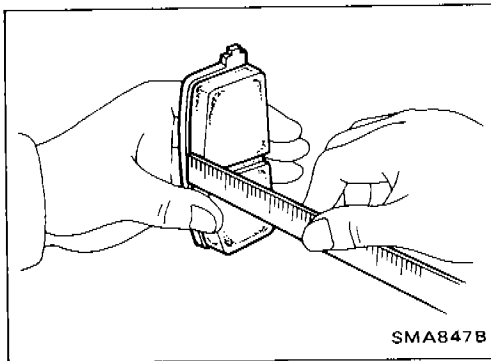

PAD

- Check for wear or damage.

Unit: mm (in)

| | Front | | Rear | |
|--------------------|---------------|--------------|---------------|--------------|
| | Except Europe | Europe | Except Europe | Europe |
| Disc brake type | CL18VB | CL25VA | CL9H | AD9 |
| Standard thickness | 10.0 (0.394) | 11.0 (0.433) | 9.5 (0.374) | 10.0 (0.394) |
| Minimum thickness | 2.0 (0.079) | | | |

Balancing Wheels

- Adjust wheel balance using road wheel center.

Wheel balance (Maximum allowable unbalance at rim flange):

Refer to S.D.S.

Tire balance weight: Refer to S.D.S.

CHASSIS AND BODY MAINTENANCE

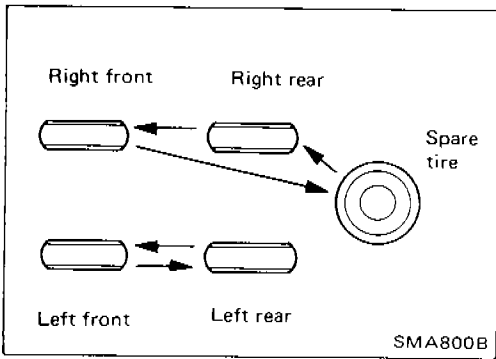

Tire Rotation

- Do not include the T-type spare tire when rotating the tires.
- Wheel nuts:
- ☑: 98 - 118 N·m
(10.0 - 12.0 kg-m, 72 - 87 ft-lb)

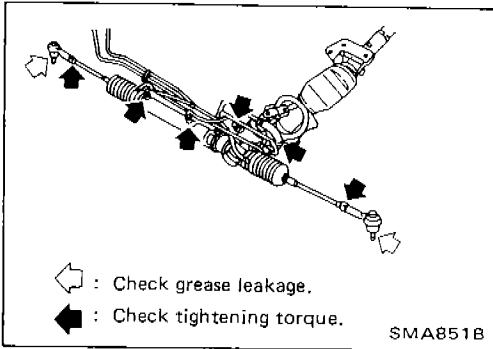

Checking Steering Gear and Linkage

STEERING GEAR

- Check gear housing and boots for looseness, damage or grease leakage.
- Check connection with steering column for looseness.

STEERING LINKAGE

- Check ball joint, dust cover and other component parts for looseness, wear, damage or grease leakage.

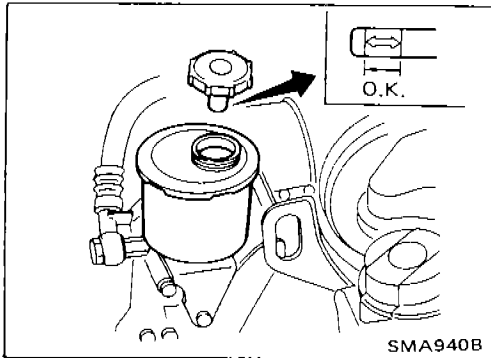

Checking Power Steering Fluid and Lines

- Check fluid level, when the fluid is cold.

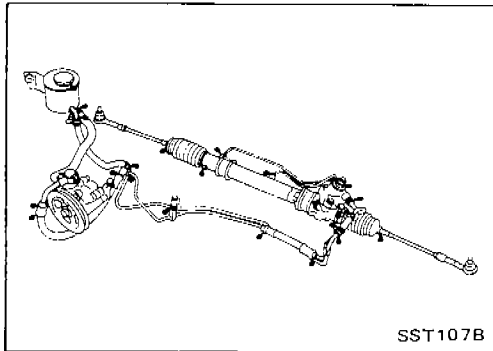

- Check lines for improper attachment, leaks, cracks, damage, loose connections, chafing and deterioration.

CHASSIS AND BODY MAINTENANCE

LUBRICATING LOCKS, HINGES AND HOOD LATCHES

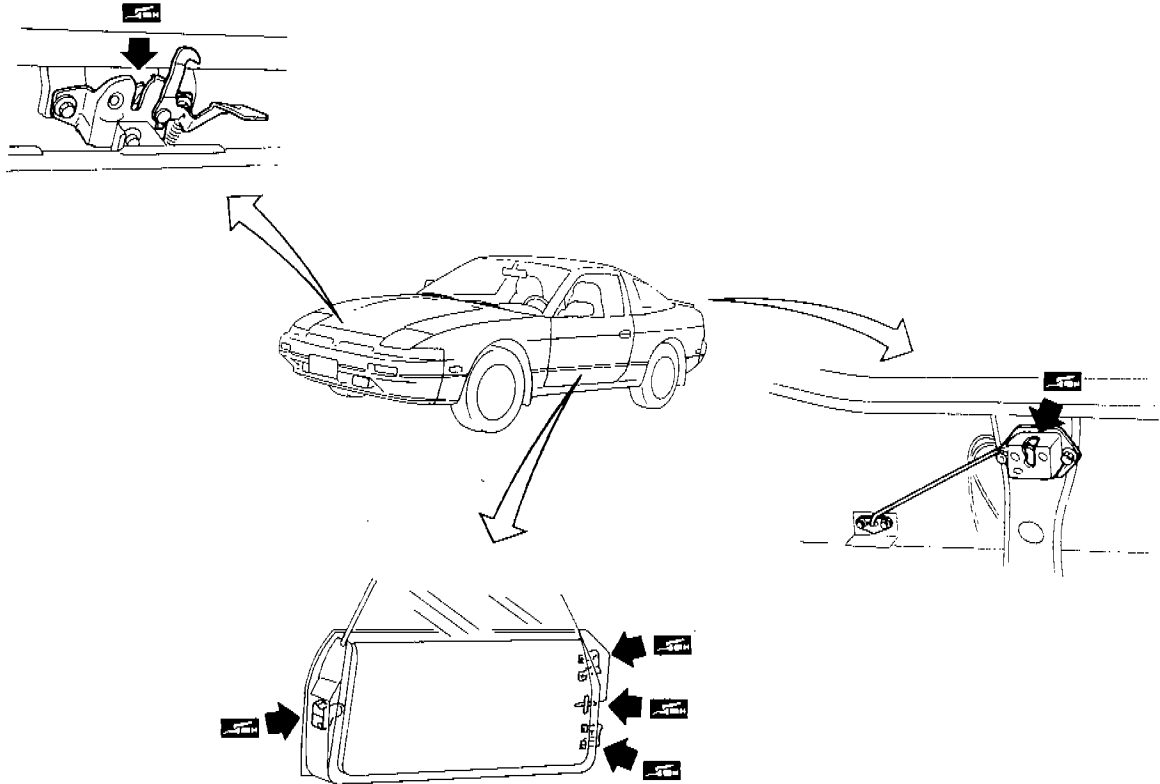

SMA045C

CHECKING SEAT BELTS, BUCKLES, RETRACTORS, ANCHORS AND ADJUSTERS

CAUTION:

1. If the vehicle is collided or overturned, replace the entire belt assembly, regardless of nature of accident.
2. If the condition of any component of a seat belt is questionable, do not have seat belt repaired, but replaced as a belt assembly.
3. If webbing is cut, frayed, or damaged, replace belt assembly.
4. Do not spill drinks, oil, etc. on inner lap belt buckle. Never oil tongue and buckle.
5. Use a NISSAN genuine seat belt assembly.

 **Anchor bolt**
24 - 31 N·m
(2.4 - 3.2 kg·m, 17 - 23 ft·lb)

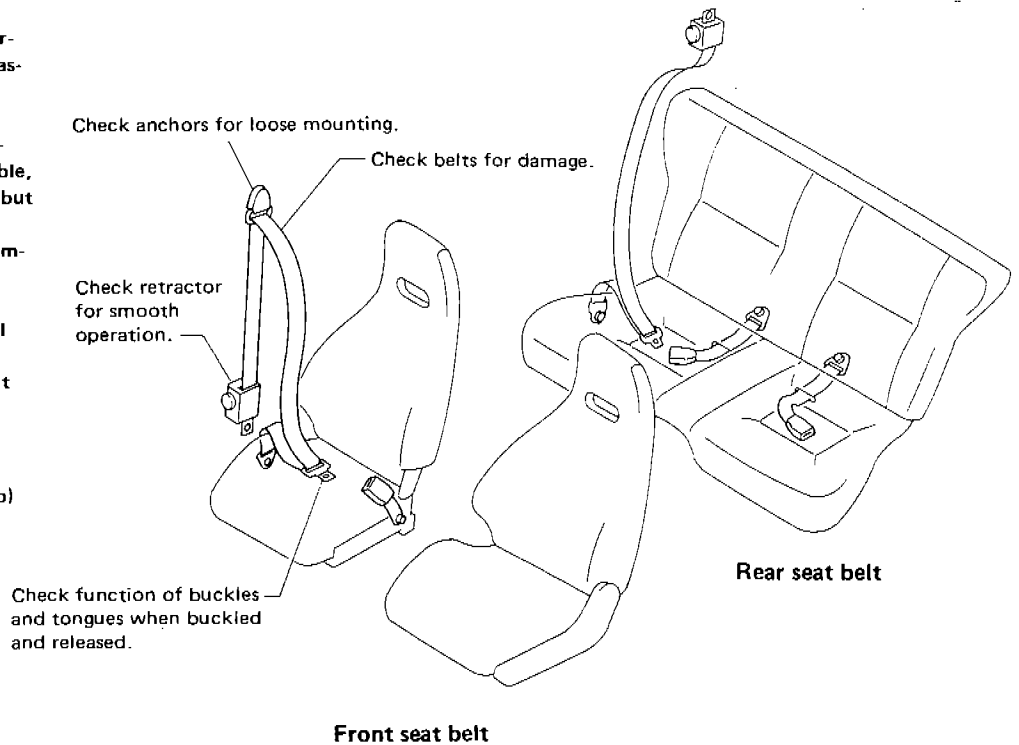

SMA046C

Checking Body Corrosion

Visually check the body sheet metal panel for corrosion, paint damage (scratches, chipping, rubbing, etc.) or damage to the anti-corrosion materials. In particular, check the following locations.

Hemmed portion

Hood front end, door lower end, trunk lid rear end, etc.

Panel joint

Side sill of rear fender and center pillar, rear wheel housing of rear fender, around strut tower in engine compartment, etc.

Panel edge

Trunk lid opening, sun roof opening, fender wheel-arch flange, fuel filler lid flange, around holes in panel, etc.

Parts contact

Waist moulding, windshield moulding, bumper, etc.

Protectors

Damage or condition of mudguard, fender protector, chipping protector, etc.

Anti-corrosion materials

Damage or separation of anti-corrosion materials under the body.

Drain holes

Condition of drain holes at door and side sill.

When repairing corroded areas, refer to the Corrosion Repair Manual.

SERVICE DATA AND SPECIFICATIONS (S.D.S.)

Engine Maintenance

INSPECTION AND ADJUSTMENT

Drive belt deflection

Unit: mm (in)

| | Used belt deflection | | Set deflection of new belt |
|----------------------------|----------------------|------------------------------|----------------------------|
| | Limit | Adjusted deflection | |
| Alternator | 8 (0.31) | 4.5 - 5.5 (0.177 - 0.217) | 4 - 5 (0.16 - 0.20) |
| Air conditioner compressor | 12 (0.47) | 7 - 9 (0.28 - 0.35) | 6 - 8 (0.24 - 0.31) |
| Power steering oil pump | 15 (0.59) | 10 - 12 (0.39 - 0.47) | 9 - 11 (0.35 - 0.43) |
| Applied pushing force | 98 N (10 kg, 22 lb) | | |

Coolant and oil capacity

Unit: ℓ (Imp qt)

| | |
|-------------------------------|---------------------|
| Coolant (with reservoir tank) | Approx. 7.0 (6-1/8) |
| Reservoir tank | 0.7 (5/8) |
| Engine oil | |
| With oil filter change | Approx. 3.5 (3-1/8) |
| Without oil filter change | Approx. 3.1 (2-3/4) |

Spark plug

Platinum-tipped type (For model with catalyzer)

| | |
|---------------|----------|
| Standard type | PFR6A-11 |
| Hot type | PFR5A-11 |
| Cold type | PFR7A-11 |

Conventional type (For model without catalyzer)

| | |
|---------------|-----------------------------------|
| Standard type | BCPR6ES-11 |
| Hot type | BCPR5ES-11 |
| Cold type | BCPR7ES-11 |
| Gap | mm (in) 1.0 - 1.1 (0.039 - 0.043) |

Cooling system

Unit: kPa (bar, kg/cm², psi)

| | |
|-----------------------------------------|----------------------------------------------|
| Radiator cap relief pressure | 78 - 98 (0.78 - 0.98, 0.8 - 1.0, 11 - 14) |
| Cooling system leakage testing pressure | 98 (0.98, 1.0, 14) |

TIGHTENING TORQUE

| Unit | N·m | kg·m | ft·lb |
|----------------------------------|-----------|-------------|-----------|
| Oil pan drain plug | 29 - 39 | 3.0 - 4.0 | 22 - 29 |
| Spark plug | 20 - 29 | 2.0 - 3.0 | 14 - 22 |
| Crank angle sensor | 7 - 8 | 0.7 - 0.8 | 5.1 - 5.8 |
| Crankshaft pulley | 142 - 152 | 14.5 - 15.5 | 105 - 112 |
| Timing belt tensioner pulley nut | 22 - 29 | 2.2 - 3.0 | 16 - 22 |

SERVICE DATA AND SPECIFICATIONS (S.D.S.)

Chassis and Body Maintenance

INSPECTION AND ADJUSTMENT

Clutch

| Model | Unit: mm (in) | |
|-----------------------|----------------------------|----------------------------|
| | R.H.D. | L.H.D. |
| Pedal free height "H" | 182 - 192 (7.17 - 7.56) | 186 - 196 (7.32 - 7.72) |
| Pedal free play "A" | 1.0 - 3.0 (0.039 - 0.118) | |

Front axle and front suspension (Unladen)*

| | | | |
|----------------------------------------------------------|---------|-------------------------|---------------|
| Camber | degree | -1°25' to 5' | |
| Caster | degree | 5°55' - 7°25' | |
| Toe-in | mm (in) | 0 - 2 (0 - 0.08) | |
| (Total toe-in) | degree | 0' - 12' | |
| Kingpin inclination | degree | 12°25' - 13°55' | |
| Front wheel turning angle Full turn Inside/Outside | degree | Except Europe L.H.D. | Europe L.H.D. |
| | | 39° - 43°/33° | 36° - 40°/32° |

*: Tankful of fuel, radiator coolant and engine oil full. Spare tire, jack, hand tools, mats in designated position.

Rear axle and rear suspension (Unladen)*

| | | | |
|-----------------|---------|------------------|--|
| Camber | degree | -1°40' to -0°40' | |
| Toe-out | mm (in) | 0 - 5 (0 - 0.20) | |
| (Total toe-out) | degree | 0' - 28' | |

*: Tankful of fuel, radiator coolant and engine oil full. Spare tire, jack, hand tools, mats in designated position.

Wheel bearing

| | Front | Rear |
|------------------------------------------------------------------|--------------------------------------|--------------------------------------|
| Wheel bearing axle end play mm (in) | 0.03 (0.0012) or less | 0.05 (0.0020) or less |
| Wheel bearing lock nut Tightening torque N-m (kg-m, ft-lb) | 147 - 216 (15 - 22, 108 - 159) | 235 - 314 (24 - 32, 174 - 231) |

Brake

Unit: mm (in)

| | | | | |
|-----------------------------------------------------------------------------------|--------------------|-----------------------------------------------------------------|-------------------------|----------------------|
| Disc brake Pad | Standard thickness | | | |
| | CL18VB | 10.0 (0.394) | | |
| | CL25VA | 11.0 (0.433) | | |
| | CL9H | 9.5 (0.374) | | |
| | AD9 | 10.0 (0.394) | | |
| | Minimum thickness | | | |
| | CL18VB, CL25VA | 2.0 (0.079) | | |
| | CL9H, AD9 | 2.0 (0.079) | | |
| | Rotor | Standard thickness | | |
| | | CL18VB | 18.0 (0.709) | |
| CL25VA | | 22.0 (0.866) | | |
| CL9H, AD9 | | 9.0 (0.354) | | |
| Minimum thickness | | | | |
| CL18VB | | 16.0 (0.630) | | |
| CL25VA | | 20.0 (0.787) | | |
| CL9H, AD9 | | 8.0 (0.315) | | |
| Pedal | | Free height | | |
| | | M/T L.H.D. | 177 - 187 (6.97 - 7.36) | |
| | R.H.D. | 178 - 188 (7.01 - 7.40) | | |
| | A/T L.H.D. | 186 - 196 (7.32 - 7.72) | | |
| | R.H.D. | 188 - 198 (7.40 - 7.80) | | |
| | Free play | 1 - 3 (0.04 - 0.12) | | |
| Depressed height [under force of 490 N (50 kg, 110 lb) with engine running] | Except Europe | L.H.D. | R.H.D. | |
| | | M/T | 90 (3.54) or more | 95 (3.74) or more |
| | Europe | M/T | 85 (3.35) or more | 90 (3.54) or more |
| | | A/T | 95 (3.74) or more | 95 (3.74) or more |
| | Parking brake | Number of notches [at pulling force 196 N (20 kg, 44 lb)] | | |
| | | 6 - 8 | | |

SERVICE DATA AND SPECIFICATIONS (S.D.S.)

Chassis and Body Maintenance (Cont'd)

Wheel balance

| | | |
|-----------------------------------------------------------------|--------|------------------------------------------|
| Wheel balance (Maximum allowable unbalance at rim flange) | g (oz) | 10 (0.35) |
| Tire balance weight | g (oz) | 5 - 60 (0.18 - 2.12) Spacing 5 (0.18) |

TIGHTENING TORQUE

| Unit | N-m | kg-m | ft-lb |
|----------------------------------------|-----------|-------------|-----------|
| Clutch | | | |
| Pedal stopper lock nut | 16 - 22 | 1.6 - 2.2 | 12 - 16 |
| Clutch switch lock nut | 12 - 15 | 1.2 - 1.5 | 9 - 11 |
| Manual transmission | | | |
| Drain and filler plugs | 25 - 34 | 2.5 - 3.5 | 18 - 25 |
| Final drive | | | |
| Drain plug | 59 - 98 | 6 - 10 | 43 - 72 |
| Filler plug | 59 - 98 | 6 - 10 | 43 - 72 |
| Front axle and front suspension | | | |
| Tie-rod lock nut | 37 - 46 | 3.8 - 4.7 | 27 - 34 |
| Camber adjusting pin | 124 - 143 | 12.6 - 14.6 | 91 - 106 |
| Rear axle and rear suspension | | | |
| Toe adjusting pin | 69 - 88 | 7.0 - 9.0 | 51 - 65 |
| Camber adjusting pin | 69 - 88 | 7.0 - 9.0 | 51 - 65 |
| Brake system | | | |
| Air bleed valve | 7 - 9 | 0.7 - 0.9 | 5.1 - 6.5 |
| Brake lamp switch lock nut | 12 - 15 | 1.2 - 1.5 | 9 - 11 |
| Brake booster input rod lock nut | 16 - 22 | 1.6 - 2.2 | 12 - 16 |
| Wheel and tire | | | |
| Wheel nut | 98 - 118 | 10.0 - 12.0 | 72 - 87 |



ENGINE MECHANICAL

SECTION **EM**

EM

CONTENTS

| | |
|------------------------------------------------|-------|
| PREPARATION | EM- 2 |
| OUTER COMPONENT PARTS | EM- 5 |
| COMPRESSION PRESSURE | EM- 6 |
| OIL PAN | EM- 7 |
| TIMING BELT | EM- 9 |
| OIL SEAL REPLACEMENT | EM-14 |
| CYLINDER HEAD | EM-16 |
| TURBOCHARGER | EM-28 |
| ENGINE REMOVAL | EM-31 |
| CYLINDER BLOCK | EM-33 |
| SERVICE DATA AND SPECIFICATIONS (S.D.S.) | EM-44 |

PREPARATION

SPECIAL SERVICE TOOLS

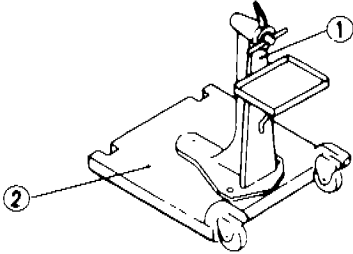
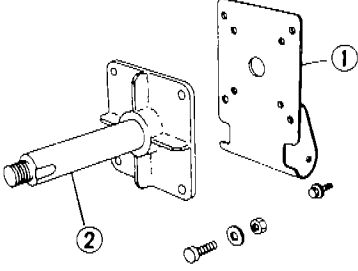
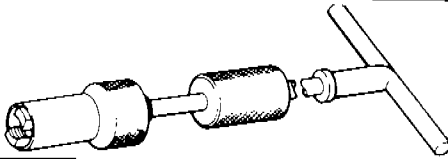
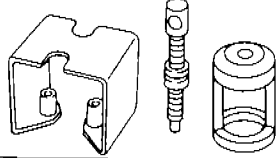
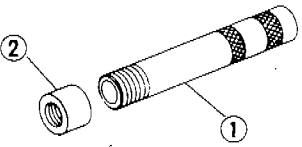

| Tool number Tool name | Description |
|---------------------------------------------------------------------------------------------------|------------------------------------------------------------------------------------------------------------------------------------------|
| ST0501S000 Engine stand assembly ① ST05011000 Engine stand ② ST05012000 Base | When overhauling engine  |
| Engine attachment assembly ① KV10108101 Engine attachment ② KV10106500 Sub-attachment |  |
| KV10107901 Valve lip seal puller | Displacement valve lip seal  |
| KV10111300 Valve spring compressor | Disassembling and assembling valve components  |
| ① KV10107501 Valve lip seal drift ② KV10111400 Valve oil seal drift attachment | Installing valve lip seal  |

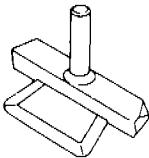
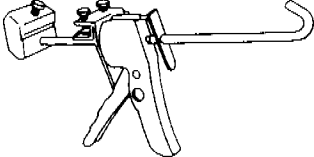
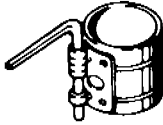
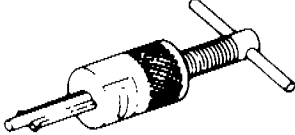
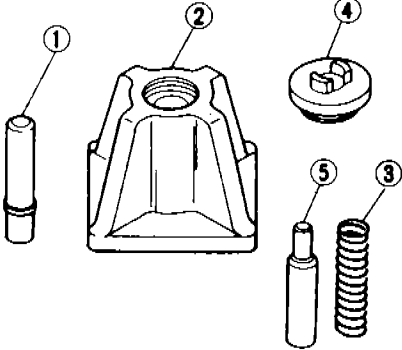
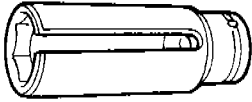
PREPARATION

| Tool number Tool name | Description |
|-------------------------------------------------------------------------------------------------------------------------------------------------------------------------|-------------------------------------------------------------------------------------------------------------------------------------------------------------------------------|
| KV10111100 Seal cutter |  <p style="text-align: right;">Removing oil pan</p> |
| WS39930000 Tube presser |  <p style="text-align: right;">Pressing the tube of liquid gasket</p> |
| EM03470000 Piston ring compressor |  <p style="text-align: right;">Installing piston assembly into cylinder bore</p> |
| ST16610001 Pilot bushing puller |  <p style="text-align: right;">Removing crankshaft pilot bushing</p> |
| KV101070S0 Piston pin press stand ① KV10107010 Center shaft ② ST13030020 Stand ③ ST13030030 Spring ④ KV10107020 Cap ⑤ ST13030051 Drift |  <p style="text-align: right;">Disassembling and assembling piston with connecting rod</p> |
| KV10113700 Exhaust gas sensor wrench |  <p style="text-align: right;">Removing and installing exhaust gas sensor</p> |

PREPARATION

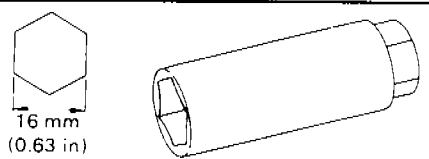
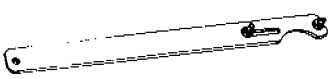
COMMERCIAL SERVICE TOOLS

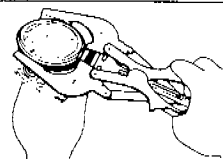
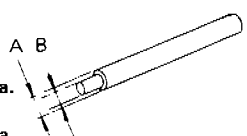
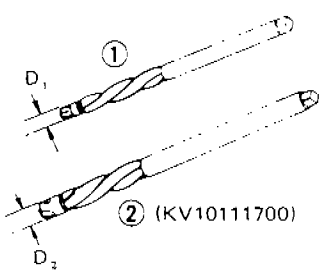
| Tool name | Description |
|-----------------------|--------------------------------------------------------------------------------------------------------------------------------------------------------------------------------------------------------------------------------------------------------------------------------------------------------------------|
| Spark plug wrench |  <p>16 mm (0.63 in)</p> <p>Removing and installing spark plug</p> |
| Pulley holder |  <p>Holding camshaft pulley while tightening or loosening camshaft bolt</p> |
| Valve seat cutter set |  <p>Finishing valve seat dimensions</p> |
| Piston ring expander |  <p>Removing and installing piston ring</p> |
| Valve guide drift | <p>Intake & Exhaust:</p> <p>A = 9.5 mm (0.374 in) dia.</p> <p>B = 5.5 mm (0.217 in) dia.</p>  <p>Removing and installing valve guide</p> |
| Valve guide reamer | <p>Reaming cylinder head for oversize valve guide ①.</p> <p>Reaming valve guide inner ②.</p>  <p>Intake & Exhaust:</p> <p>D₁ = 6.0 mm (0.236 in) dia.</p> <p>D₂ = 10.2 mm (0.402 in) dia.</p> |

OUTER COMPONENT PARTS

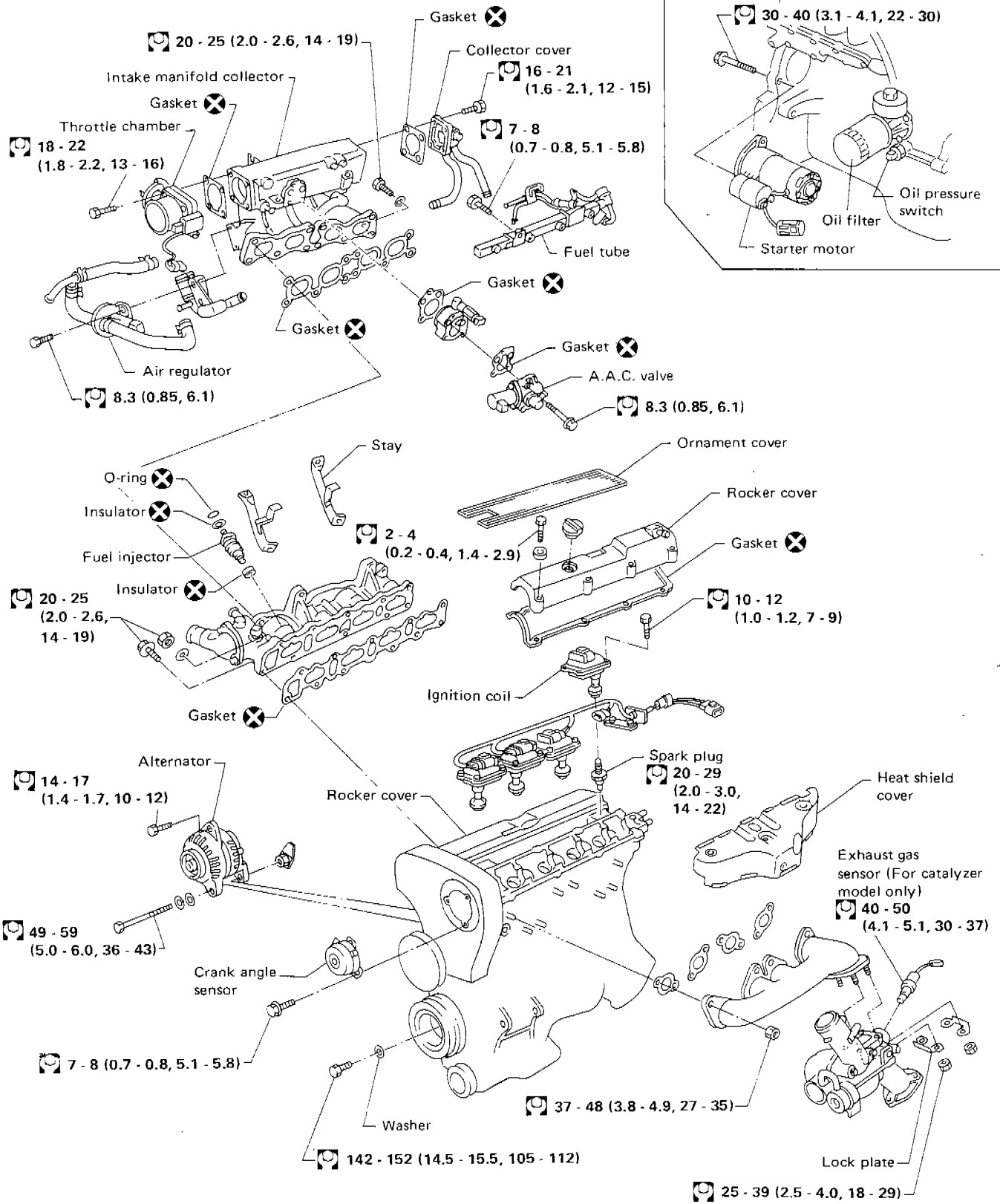

☐ : N·m (kg·m, ft·lb)

SEM352C

EM-5

COMPRESSION PRESSURE

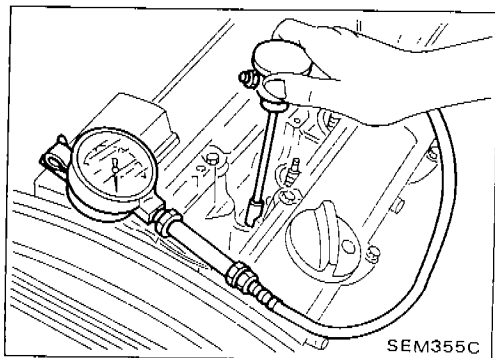
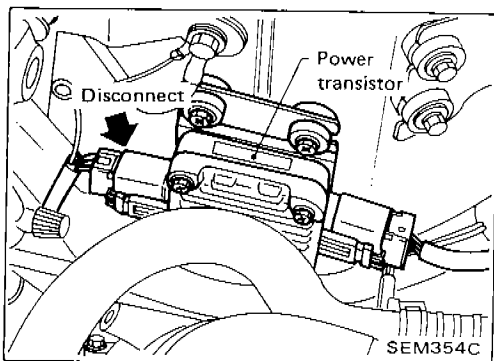

Measurement of Compression Pressure

1. Warm up engine.
 2. Turn ignition switch off.
 3. Release fuel pressure.
Refer to "Releasing Fuel Pressure" in section EF & EC.
 4. Remove all spark plugs.
 5. Disconnect power transistor harness connector.
 6. Attach a compression tester to No. 1 cylinder.
 7. Depress accelerator pedal fully to keep throttle valve wide open.
 8. Crank engine and record highest gauge indication.
 9. Repeat the measurement on each cylinder as shown above.
- **Always use a fully-charged battery to obtain specified engine revolution.**

Compression pressure:

kPa (bar, kg/cm², psi)/rpm

Standard

1,177 (11.77, 12.0, 171)/350

Minimum

981 (9.81, 10.0, 142)/350

Differential limit between cylinders

98 (0.98, 1.0, 14)/350

10. If cylinder compression in one or more cylinders is low, pour a small amount of engine oil into cylinders through spark plug holes and retest compression.
- **If adding oil helps compression, piston rings may be worn or damaged. If so, replace piston rings after checking piston.**
 - **If pressure stays low, a valve may be sticking or seating improperly. Inspect and repair valve and valve seat. (Refer to S.D.S.) If valve or valve seat is damaged excessively, replace them.**
 - **If compression in any two adjacent cylinders is low and if adding oil does not help compression, there is leakage past the gasket surface. If so, replace cylinder head gasket.**

OIL PAN

Removal

1. Drain engine oil.
2. Remove front stabilizer bar.
3. Loosen front engine mounting nuts. (Do not loosen completely.)
4. Lift up engine slightly using engine slingers.

5. Remove oil pan.

(1) Insert Tool between cylinder block and oil pan.

- Do not insert Tool into oil pump or rear oil seal retainer portion, or aluminum mating face will be damaged.
- Do not insert screwdriver, or oil pan flange will be deformed.

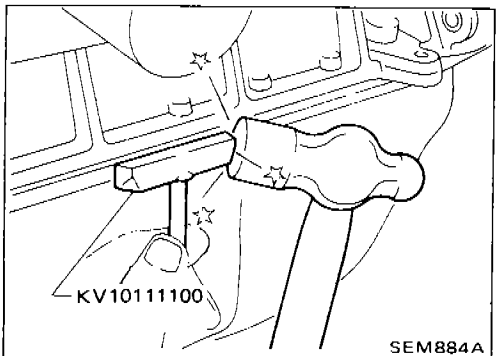
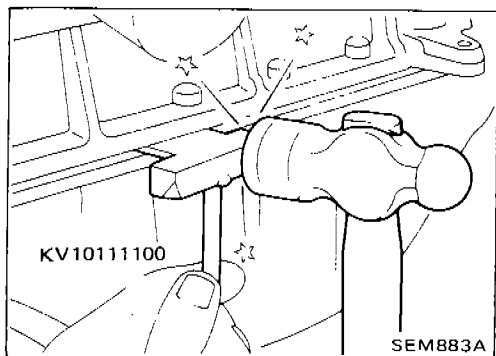

(2) Slide Tool by tapping its side with a hammer, and remove oil pan.

Installation

1. Before installing oil pan, remove all traces of liquid gasket from mating surface using a scraper.
 - Also remove traces of liquid gasket from mating surface of cylinder block.

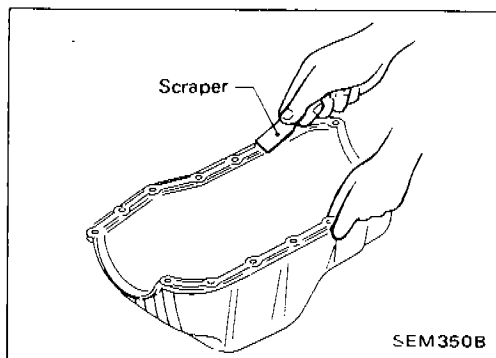

2. Apply liquid gasket to oil pump gasket and rear oil seal retainer gasket.

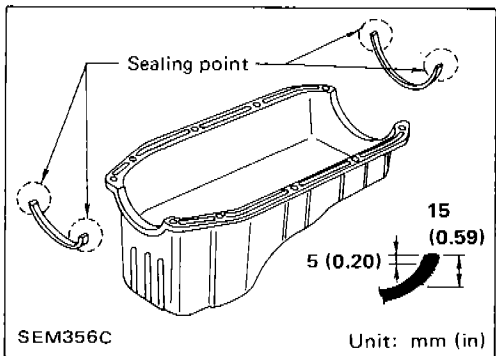

OIL PAN

Installation (Cont'd)

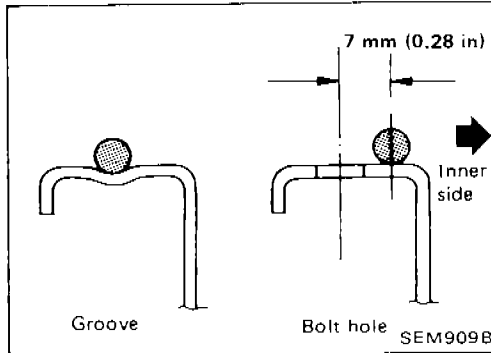
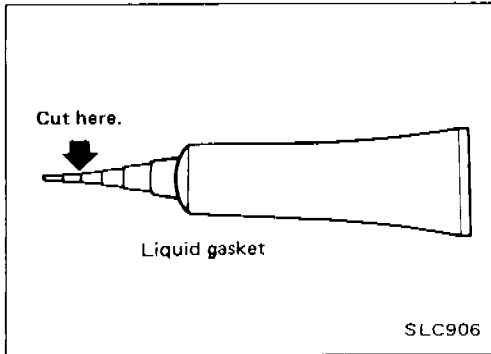
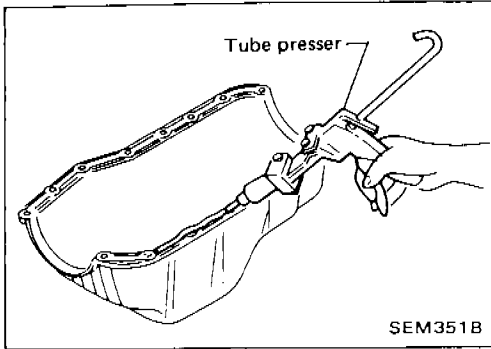

3. Apply a continuous bead of liquid gasket to mating surface of oil pan.
 - Use Genuine Liquid Gasket or equivalent.
- Be sure liquid gasket is 3.5 to 4.5 mm (0.138 to 0.177 in) wide.
4. Apply liquid gasket to inner sealing surface as shown in figure.
 - Attaching should be done within 5 minutes after coating.
5. Install oil pan.
 - Wait at least 30 minutes before refilling engine oil.

TIMING BELT

CAUTION:

- a. Do not bend or twist timing belt.
- b. After removing timing belt, do not turn crankshaft and camshaft separately because valves will strike piston heads.
- c. Make sure that timing belt, camshaft sprocket, crankshaft sprocket and belt tensioner are clean and free from oil and water.

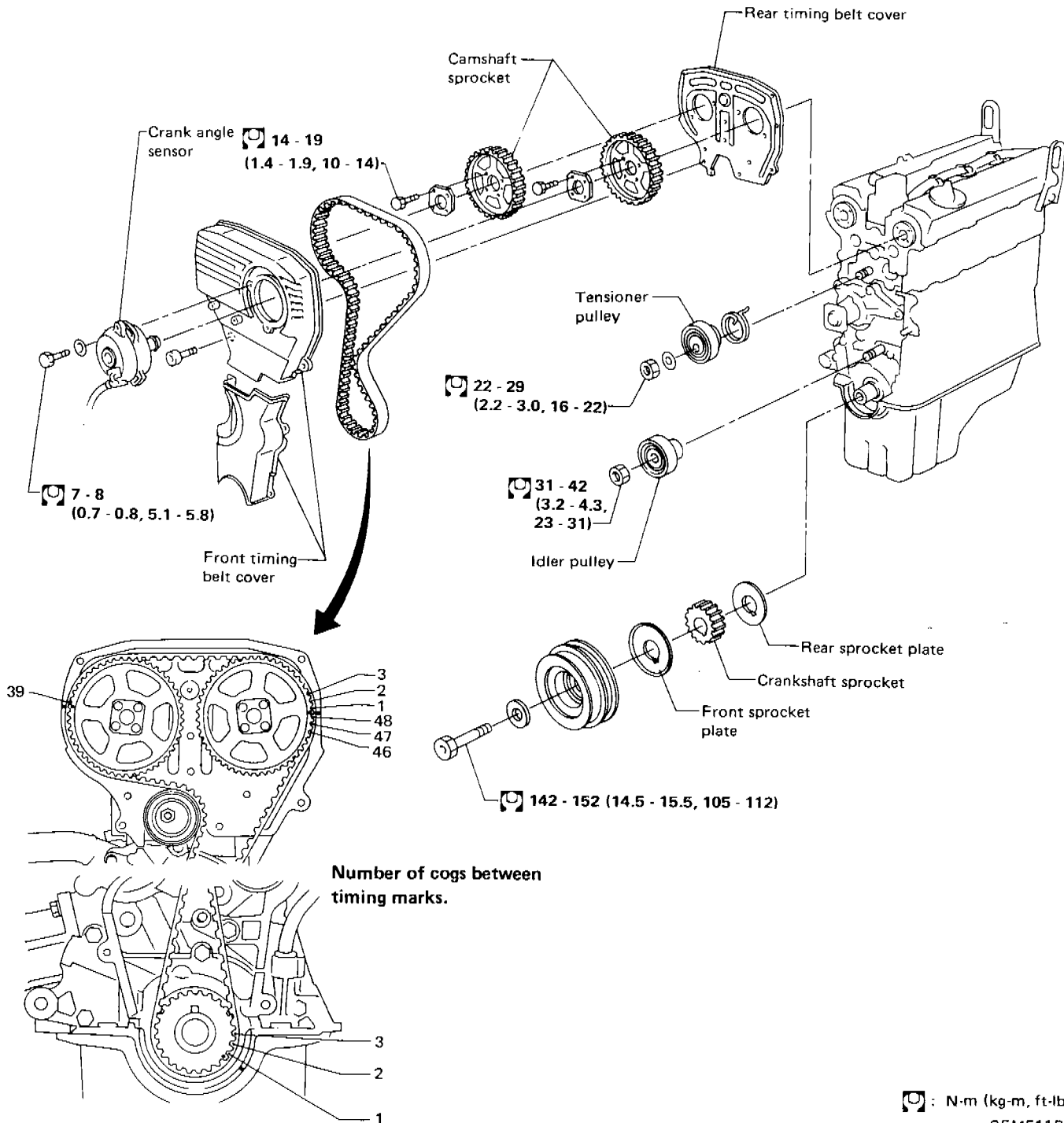

: N·m (kg·m, ft·lb)
SEM511B

TIMING BELT

Removal

1. Drain engine coolant from radiator.
Be careful not to spill coolant on drive belts.
2. Remove air duct, upper radiator hose, radiator shroud and under cover.
3. Remove the following belts.
 - Power steering pump drive belt
 - Compressor drive belt
 - Alternator drive belt
4. Remove water pump pulley, fan and fan coupling.
5. Remove crank angle sensor.
Put aligning mark on crank angle sensor and timing belt cover.

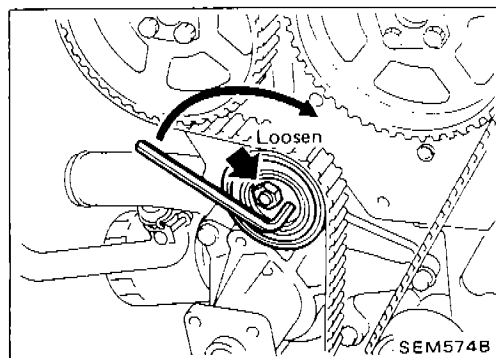
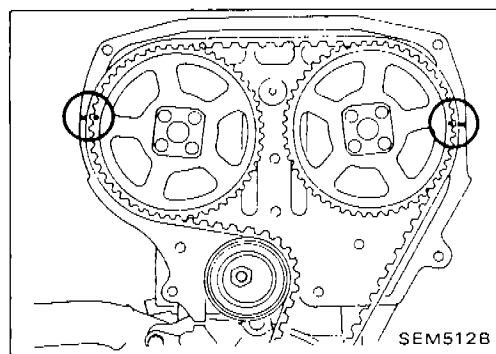
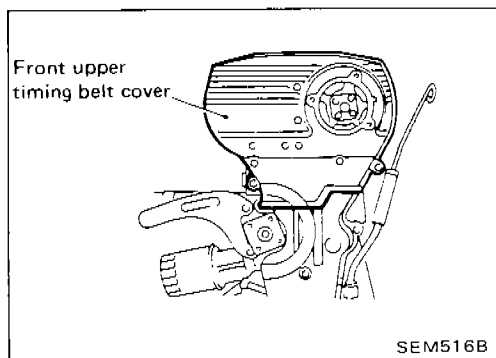
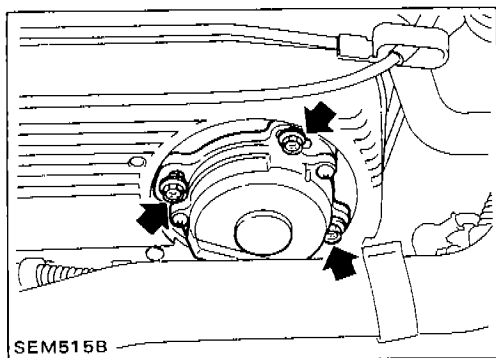

6. Remove front upper timing belt cover.
7. Remove all spark plugs.
8. Set No. 1 piston at T.D.C. on its compression stroke.
9. Remove crankshaft pulley.
10. Remove front lower timing belt cover.
11. Loosen timing belt tensioner nut, turn tensioner, then remove timing belt.

TIMING BELT

Inspection

Visually check the condition of timing belt.
Replace if any abnormality is found.

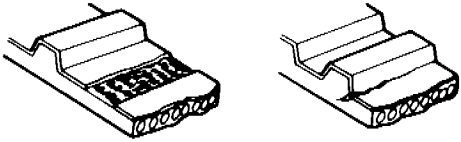
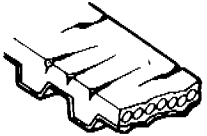
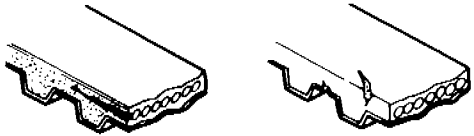
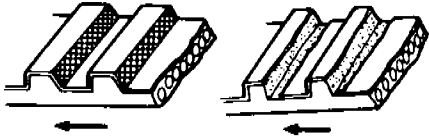
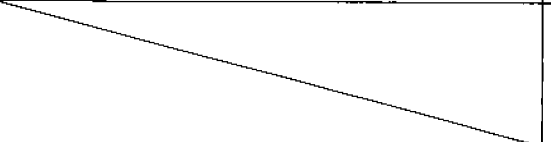
| Item to check | Problem | Cause |
|-----------------------------------------------|-------------------------------------------------------------------------------------------------------------------------------------------------------------------------------------------------------------------------------------------------------------------------------------------------------------------------------------------------------------------------------------------------|-----------------------------------------------------------------------------------------------------------------------------------------------------------------------------------------------------------------------------------------------------|
| Tooth is broken/ tooth root is cracked. |  <p style="text-align: right;">SEM394A</p> | <ul style="list-style-type: none"> ● Camshaft jamming ● Distributor jamming ● Damaged camshaft/crankshaft oil seal |
| Back surface is cracked/worn. |  <p style="text-align: right;">SEM395A</p> | <ul style="list-style-type: none"> ● Tensioner jamming ● Overheated engine ● Interference with belt cover |
| Side surface is worn. |  <ul style="list-style-type: none"> ● Belt corners are worn and round. ● Wicks are frayed and coming out. <p style="text-align: right;">SEM396A</p> | <ul style="list-style-type: none"> ● Improper installation of belt ● Malfunctioning crankshaft pulley plate/ timing belt plate |
| Teeth are worn. |  <p style="text-align: center;">Rotating direction</p> <ul style="list-style-type: none"> ● Canvas on tooth face is worn down. ● Canvas on tooth is fluffy, rubber layer is worn down and faded white, or weft is worn down and invisible. <p style="text-align: right;">SEM397A</p> | <ul style="list-style-type: none"> ● Poor belt cover sealing ● Coolant leakage at water pump ● Camshaft not functioning properly ● Distributor not functioning properly ● Excessive belt tension |
| Oil/Coolant or water is stuck to belt. |  | <ul style="list-style-type: none"> ● Poor oil sealing of each oil seal ● Coolant leakage at water pump ● Poor belt cover sealing |

TIMING BELT

Inspection (Cont'd)

BELT TENSIONER, IDLER PULLEY AND TENSIONER SPRING

1. Check belt tensioner and idler pulley for smooth turning.
2. Check condition of tensioner spring.

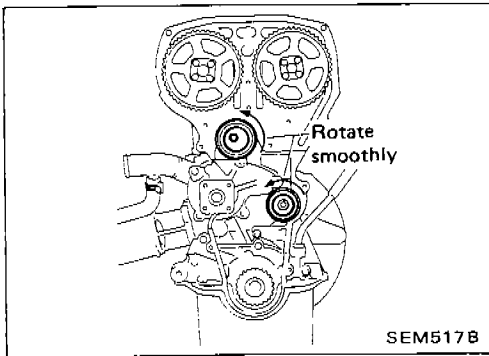

Installation

1. Confirm that No. 1 piston is set at T.D.C. on its compression stroke.
2. Install tensioner and tensioner spring.
 - Turn tensioner fully clockwise with hexagon wrench, and temporarily tighten lock nut.

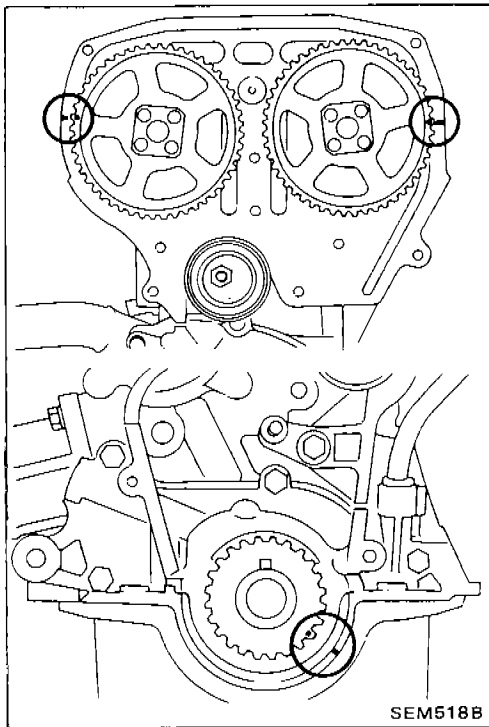

3. Set timing belt.

Align timing marks on timing belt and sprockets.

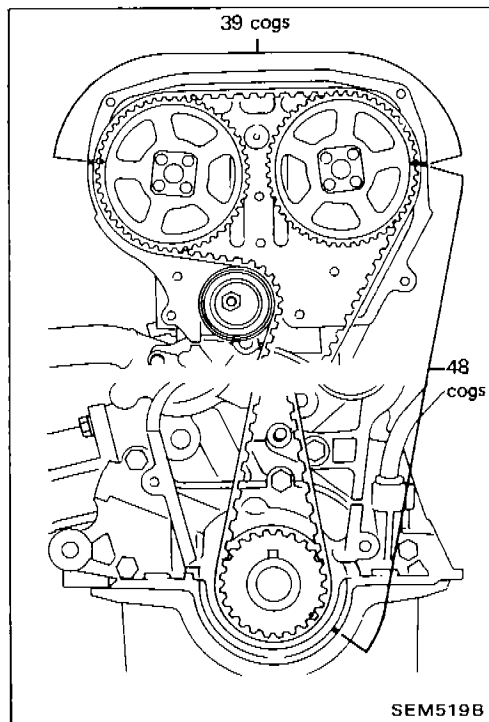

TIMING BELT

Installation (Cont'd)

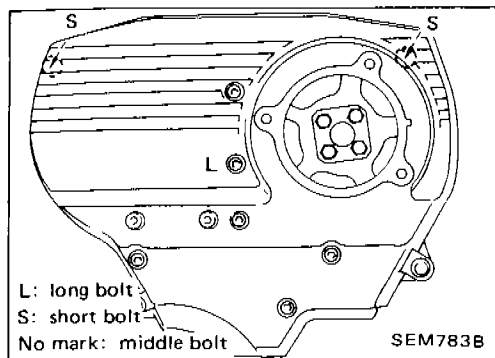
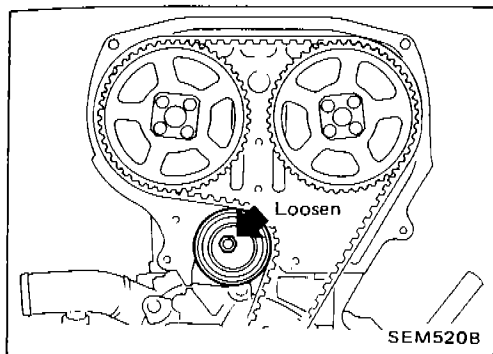

4. Loosen tensioner lock nut, keeping tensioner steady with hexagon wrench.
5. Rotate crankshaft at least two turns clockwise.
6. Adjust belt tension.
Slowly swing tensioner with hexagon wrench clockwise and counterclockwise two or three times.
7. Tighten tensioner lock nut.

8. Install lower and upper timing belt covers.

9. Install crankshaft pulley with washer.
10. Install engine mount bracket.
11. Install crank angle sensor and water pump pulley.
Align marks on crank angle sensor and front cover that were made when crank angle sensor was removed.

OIL SEAL REPLACEMENT

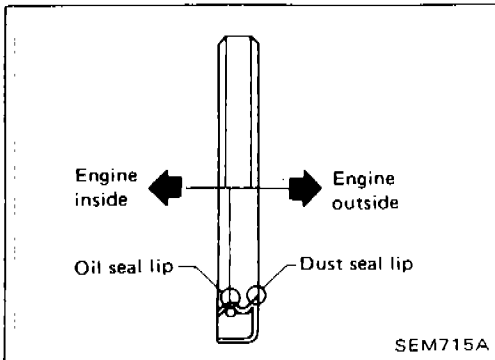

OIL SEAL INSTALLING DIRECTION

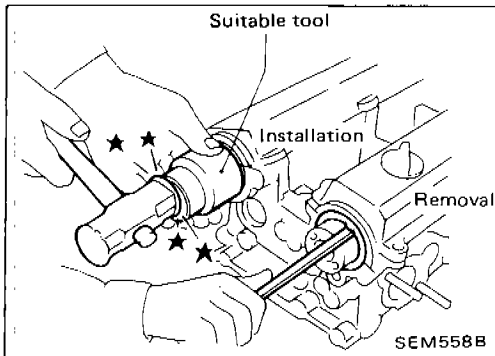

CAMSHAFT OIL SEAL

1. Set No. 1 piston at T.D.C. on its compression stroke.
 2. Remove crank angle sensor, front cover, timing belt, camshaft sprockets and rear dust cover.
 3. Remove camshaft oil seal.
- Be careful not to scratch camshaft.**
4. Apply engine oil to camshaft oil seal lip and install it in place.

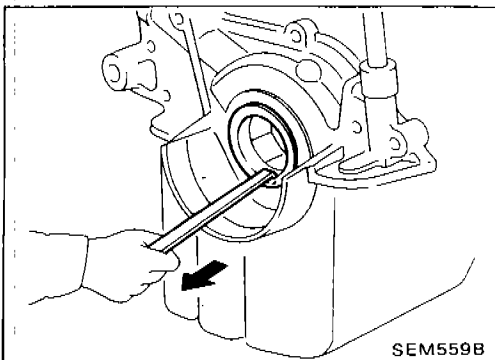

FRONT OIL SEAL

1. Set No. 1 piston at T.D.C. on its compression stroke.
2. Remove timing belt and crankshaft sprocket.
3. Remove front oil seal.
4. Apply engine oil to oil seal lip and install it in place using suitable tool.

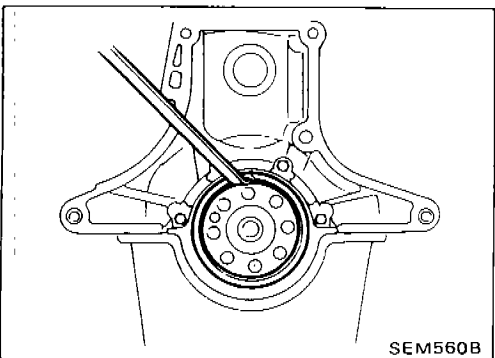

REAR OIL SEAL

1. Remove transmission and flywheel.
2. Remove rear oil seal from the retainer.
3. Apply engine oil to oil seal lip and install it in place using suitable tool.

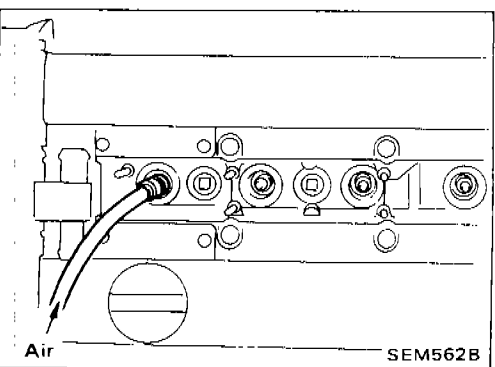

VALVE OIL SEAL

1. Set No. 1 piston at T.D.C. on its compression stroke.
2. Remove throttle chamber and rocker covers.
3. Remove camshafts and valve lifters.
4. Remove spark plug.
5. Install air hose adapter into spark plug hole and apply air pressure to hold valves in place. [Apply pressure of 490 kPa (4.9 bar, 5 kg/cm², 71 psi)].

CYLINDER HEAD

Assembly (Cont'd)

Install camshaft as shown.

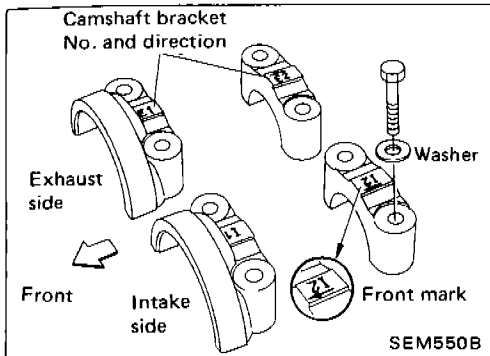
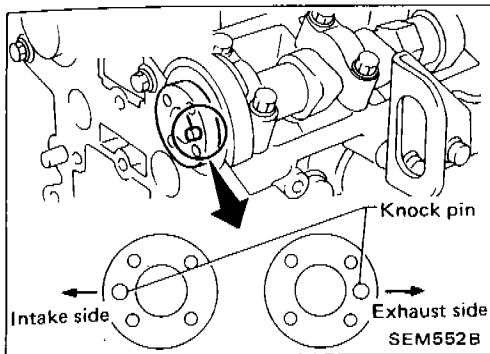

3. Install camshaft brackets.

Front mark is punched on the camshaft bracket.

4. Apply engine oil to camshaft oil seal lip and install it in place.

Always use new camshaft oil seal.

\square : 9 - 12 N·m (0.9 - 1.2 kg-m, 6.5 - 8.7 ft-lb)

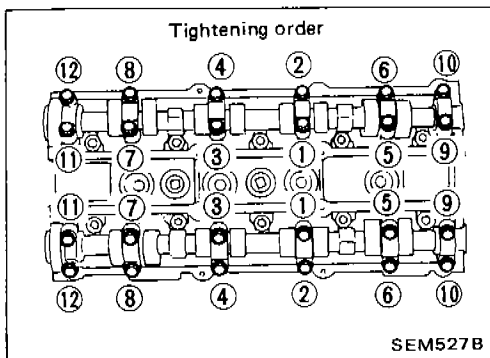

Tighten camshaft bracket bolts gradually in two or three stages.

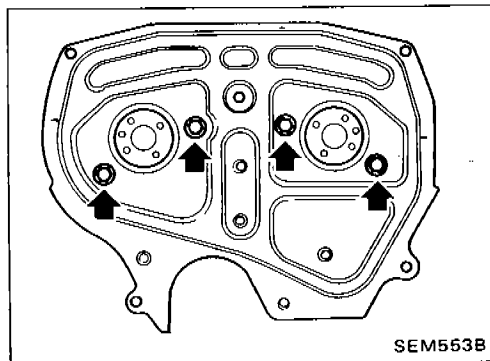

5. Install rear timing cover.

\square : 7 - 8 N·m (0.7 - 0.8 kg-m, 5.1 - 5.8 ft-lb)

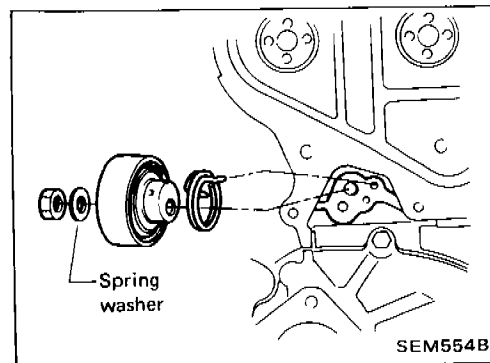

6. Install timing belt tensioner.

Tensioner nut:

\square : 22 - 29 N·m (2.2 - 3.0 kg-m, 16 - 22 ft-lb)

CYLINDER HEAD

Assembly (Cont'd)

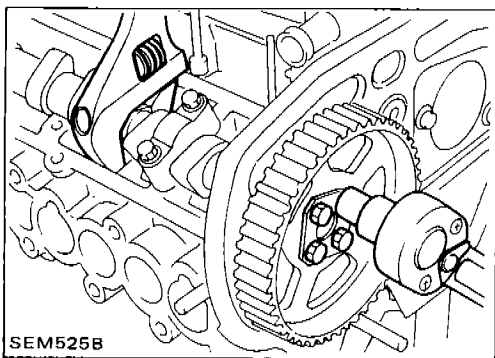

7. Install camshaft sprockets.

Sprocket bolt:

: 14 - 19 N·m (1.4 - 1.9 kg-m, 10 - 14 ft-lb)

When tightening bolts, fix camshaft to prevent it from rotating.

8. Adjust timing belt tension.

Refer to **TIMING BELT**.

9. Reinstall remaining parts.

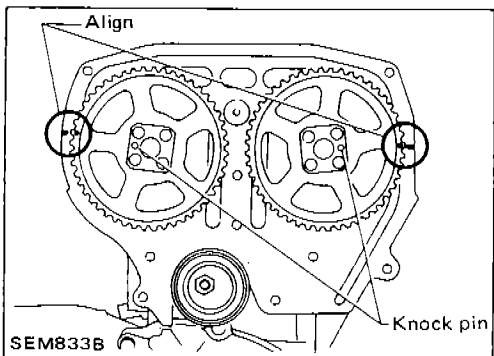
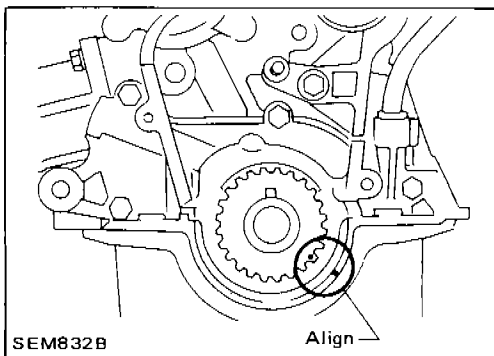

Installation

1. Set No. 1 piston at T.D.C. on its compression stroke as follows:

(1) Align crankshaft sprocket aligning mark with mark on oil pump body.

(2) Align camshaft sprocket aligning mark with mark on timing belt rear cover.

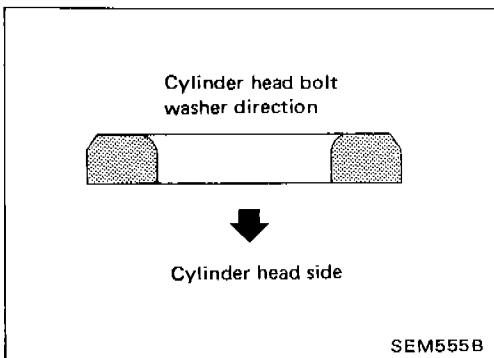

2. Install cylinder head with new gasket.

● **Be sure to install washers between bolts and cylinder head.**

● **Do not rotate crankshaft and camshaft separately, or valves will hit piston heads.**

TURBOCHARGER

Inspection

Condition 1: Low engine power

Probable cause

Air leak at the connection of compressor housing and suction hose/inlet tube, or inlet tube and intake manifold



Corrective action

Correct the connection.

Exhaust gas leak at the connection of turbine housing and exhaust manifold, connecting tube or exhaust outlet



Correct the connection or replace gasket.

By-pass valve is stuck open.



Stuck or worn journal or bearing



Broken shaft



Sludge on back of turbine wheel



Broken turbine wheel



Replace turbocharger assembly.

Condition 2: Excessively high engine power

Probable cause

Disconnected or cracked rubber hose of by-pass valve controller



Corrective action

Correct or replace rubber hose.

By-pass valve is stuck closed.



Controller diaphragm is broken.



Replace turbocharger assembly.

TURBOCHARGER

Inspection (Cont'd)

Condition 3: Excessively high oil consumption or exhaust shows pale blue smoke

Probable cause

Corrective action

Oil leak at the connection of lubricating oil passage

Correct the connection.

Oil leak at oil seal of turbine

Oil leak at oil seal of compressor

Worn journal or bearing

Replace turbocharger assembly.

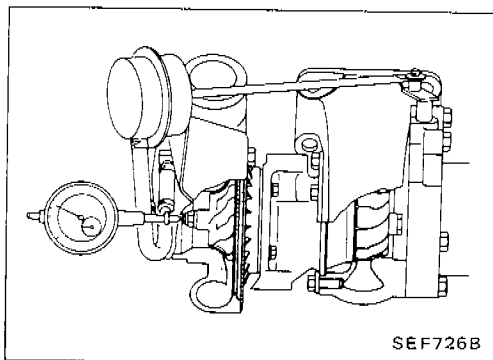

1. Inspect turbine and compressor wheel as follows:
 - Visually check for cracks, clogging, deformity or other damage.
 - Revolve wheels to make sure that they turn freely without any abnormal noise or friction.
 - Measure play in axial direction.

Play (axial direction):

0.013 - 0.097 mm (0.0005 - 0.0038 in)

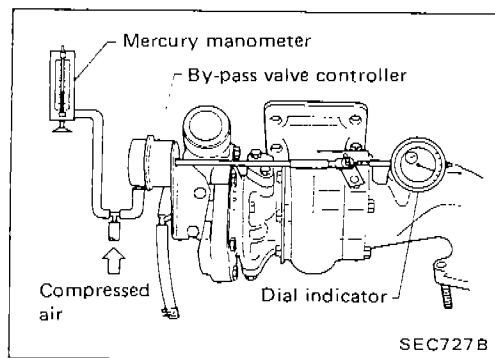

2. Check operation of by-pass valve controller.
 - Move by-pass valve to make sure that it is not sticking or scratched.
 - Measure rod end play of the by-pass valve controller.

Do not apply excessively high pressure to controller diaphragm.

By-pass valve controller stroke/pressure:

0.38 mm (0.0150 in)/78.6 - 84.0 kPa (786 - 840 mbar,
590 - 630 mmHg, 23.23 - 24.80 inHg)

Always replace the turbocharger as an assembly if necessary.

ENGINE REMOVAL

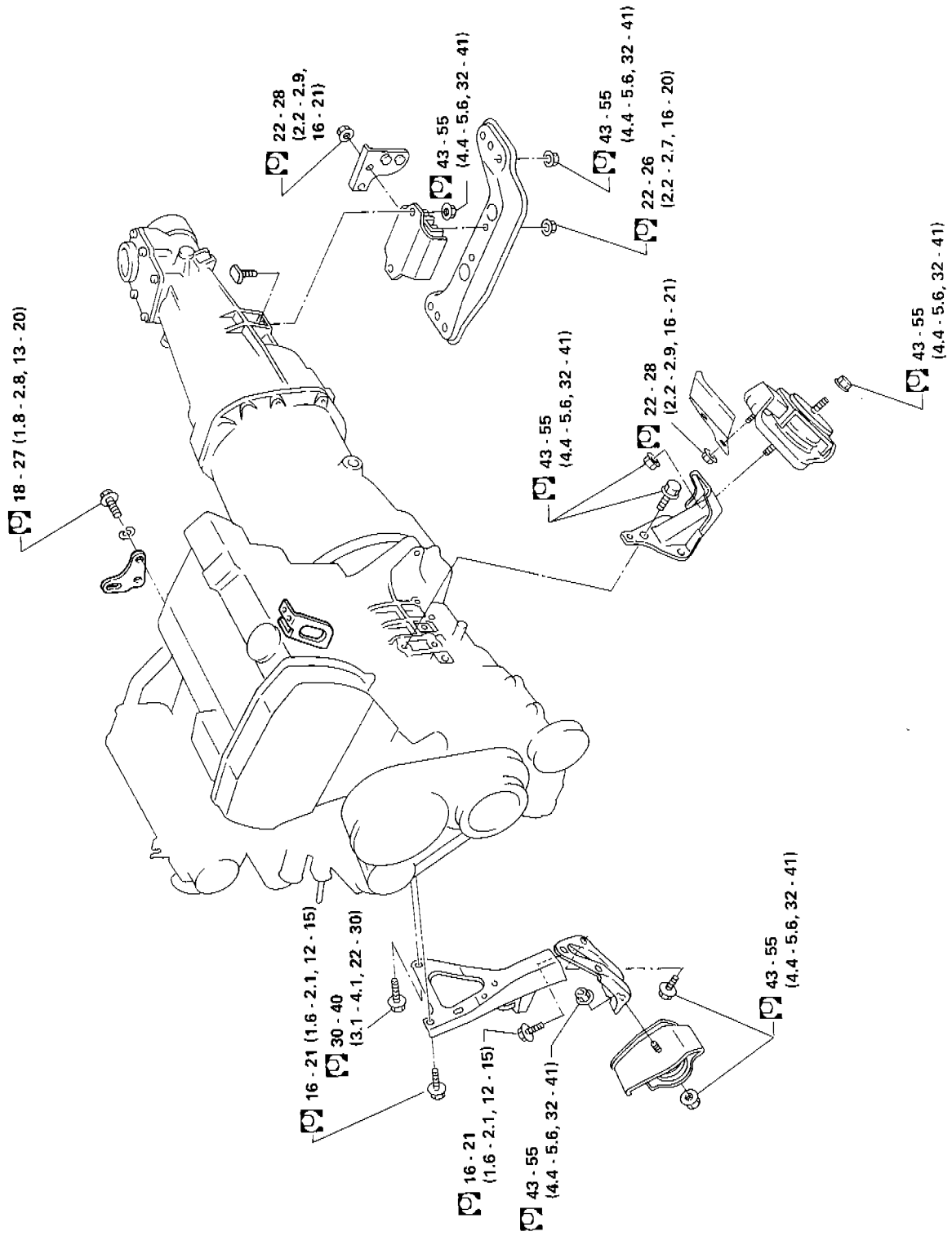

: N.m (kg-m, ft-lb)

ENGINE REMOVAL

WARNING:

- a. Situate vehicle on a flat and solid surface.
- b. Place chocks at front and back of rear wheels.
- c. Do not remove engine until exhaust system has completely cooled off.
Otherwise, you may burn yourself and/or fire may break out in fuel line.
- d. For safety during subsequent steps, the tension of wires should be slackened against the engine.
- e. Before disconnecting fuel hose, release fuel pressure from fuel line.
Refer to "Releasing Fuel Pressure" in section EF & EC.
- f. Be sure to hoist engine and transmission in a safe manner.
- g. For engines not equipped with engine slingers, attach proper slingers and bolts described in PARTS CATALOG.

CAUTION:

- When lifting engine, be careful not to strike adjacent parts, especially accelerator wire casing, brake lines, and brake master cylinder.
- In hoisting the engine, always use engine slingers in a safe manner.
- Do not loosen front engine mounting insulator cover securing nuts.
When cover is removed, damper oil flows out and mounting insulator will not function.
For tightening torque, refer to sections AT, MT and PD.

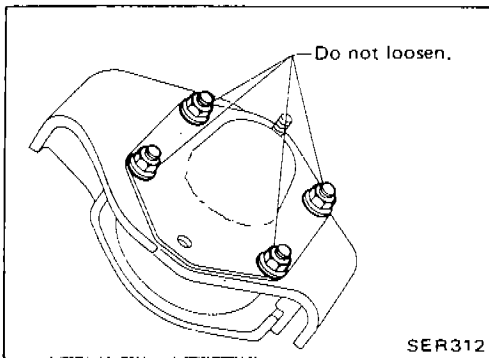

CYLINDER BLOCK

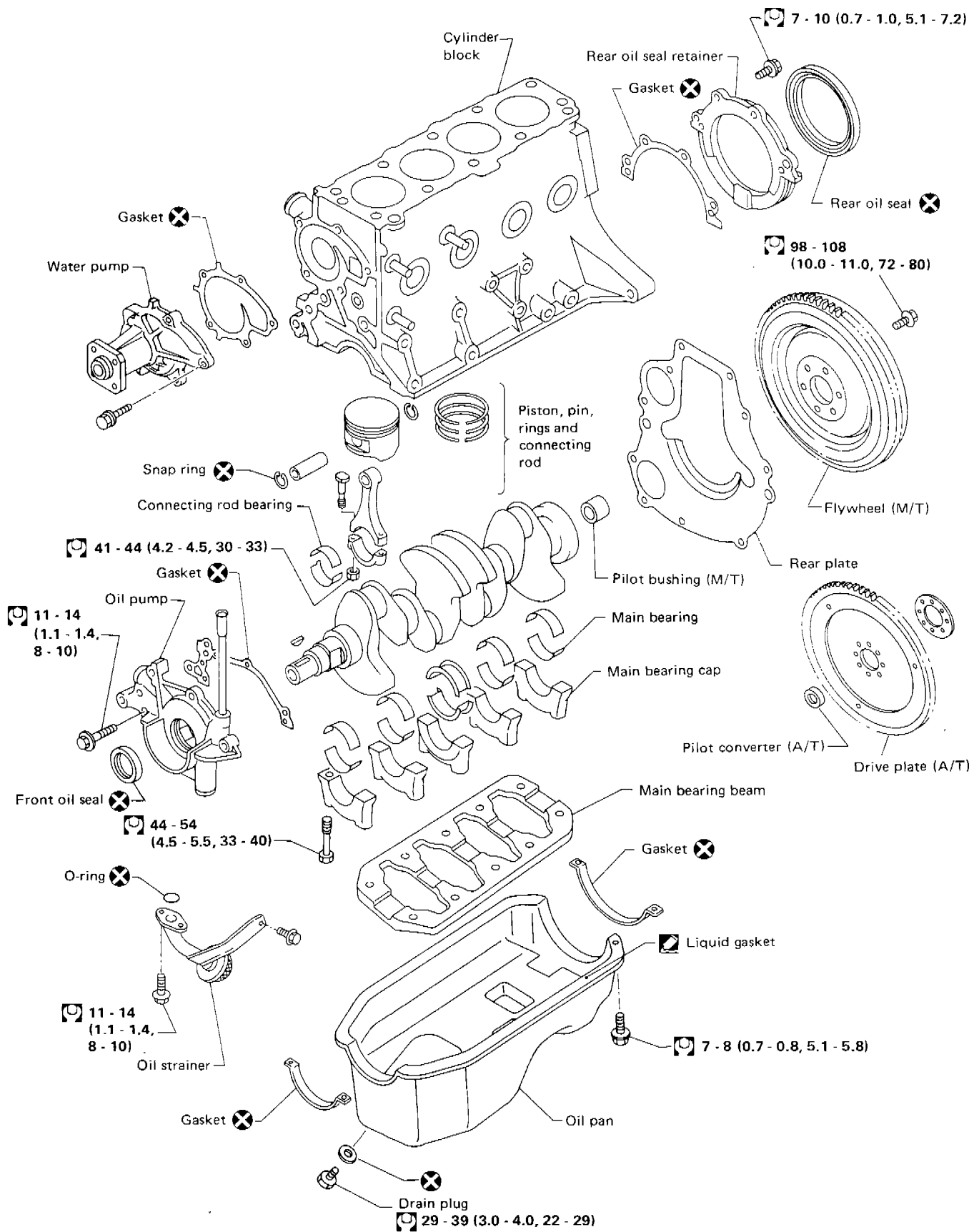

☐ : N·m (kg·m, ft·lb)

SEM359C

CYLINDER BLOCK

CAUTION:

- When installing sliding parts such as bearings and pistons, be sure to apply engine oil on the sliding surfaces.
- Place removed parts such as bearings and bearing caps in their proper order and direction.
- When tightening connecting rod bolts and main bearing cap bolts, apply engine oil to thread portion of bolts and seating surface of nuts.

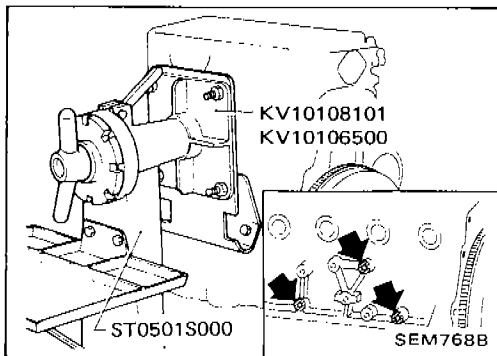

Disassembly

PISTON AND CRANKSHAFT

1. Place engine on a work stand.
2. Remove timing belt.
3. Drain coolant and remove water pump.
4. Drain oil.
5. Remove oil pan and oil pump.
6. Remove cylinder head.
7. Remove pistons.
 - When disassembling piston and connecting rod, remove snap ring first, then heat piston to 60 to 70°C (140 to 158°F) or use piston pin press stand at room temperature.

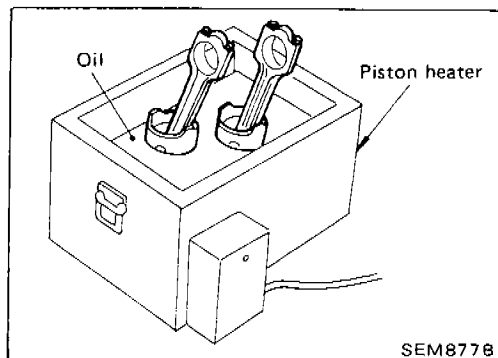

8. Remove bearing cap and crankshaft.
 - Before removing bearing cap, measure crankshaft end play.
 - Bolts should be loosened in two or three steps.

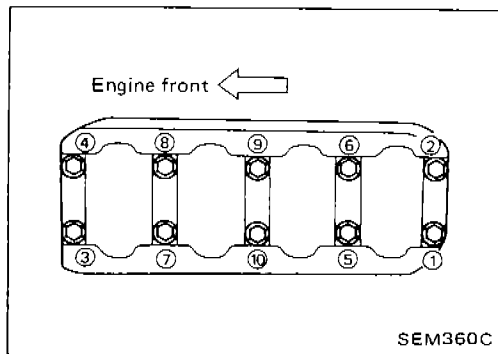

Inspection

PISTON RING SIDE CLEARANCE

Side clearance:

Top ring

0.040 - 0.073 mm (0.0016 - 0.0029 in)

2nd ring

0.030 - 0.063 mm (0.0012 - 0.0025 in)

Max. limit of side clearance:

0.1 mm (0.004 in)

If out of specification, replace piston and/or piston ring assembly.

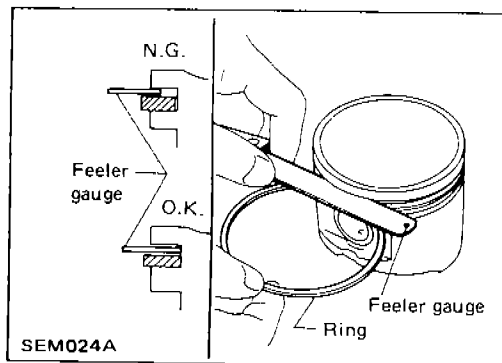

CYLINDER BLOCK

Inspection (Cont'd)

PISTON RING END GAP

End gap:

Top ring

0.25 - 0.42 mm (0.0098 - 0.0165 in)

2nd ring

0.38 - 0.64 mm (0.0150 - 0.0252 in)

Oil ring

0.20 - 0.76 mm (0.0079 - 0.0299 in)

Max. limit of ring gap:

1.0 mm (0.039 in)

If out of specification, replace piston ring. If gap still exceeds the limit even with a new ring, rebore cylinder and use oversized piston and piston rings.

Refer to S.D.S.

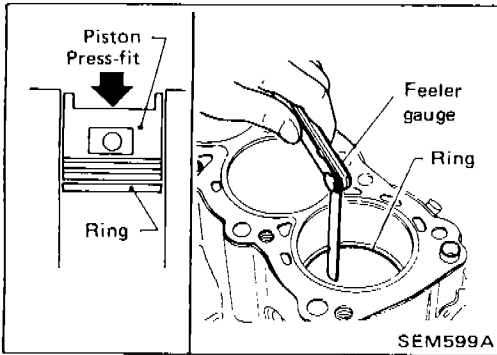

CONNECTING ROD BEND AND TORSION

Bend and torsion:

Limit 0.1 mm (0.004 in)

per 100 mm (3.94 in) length

If it exceeds the limit, replace connecting rod assembly.

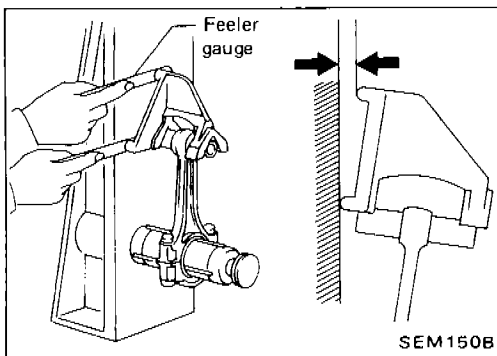

CYLINDER BLOCK DISTORTION AND WEAR

1. Clean upper face of cylinder block and measure the distortion.

Limit:

0.10 mm (0.0039 in)

2. If out of specification, resurface it.

The resurfacing limit is determined by cylinder head resurfacing in engine.

Amount of cylinder head resurfacing is "A".

Amount of cylinder block resurfacing is "B".

The maximum limit is as follows:

$A + B = 0.2 \text{ mm (0.008 in)}$

Nominal cylinder block height

from crankshaft center:

204.75 - 204.85 mm (8.0610 - 8.0649 in)

3. If necessary, replace cylinder block.

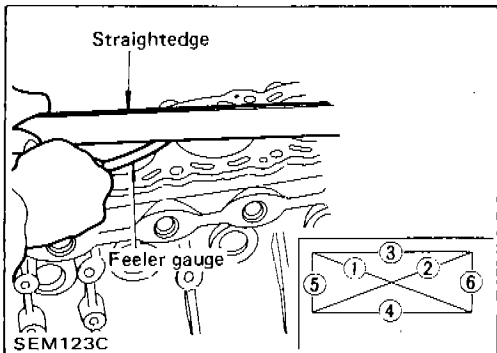

CYLINDER BLOCK

Inspection (Cont'd)

PISTON-TO-BORE CLEARANCE

1. Using a bore gauge, measure cylinder bore for wear, out-of-round and taper.

Standard inner diameter:

83.000 - 83.050 mm (3.2677 - 3.2697 in)

Wear limit:

0.20 mm (0.0079 in)

Out-of-round (X - Y) limit:

0.015 mm (0.0006 in)

Taper (A - B) limit:

0.010 mm (0.0004 in)

If it exceeds the limit, rebore all cylinders. Replace cylinder block if necessary.

2. Check for scratches and seizure. If seizure is found, hone it.

- If both cylinder block and pistons are replaced with new ones, select pistons having the same piston grade numbers as those punched on the cylinder block upper surfaces.

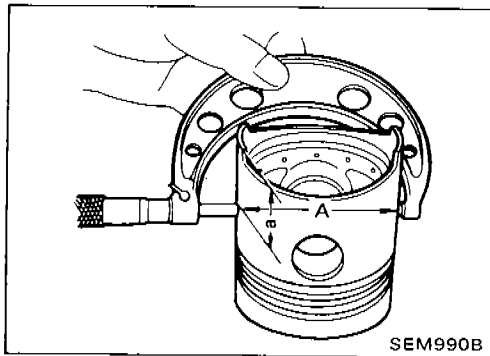
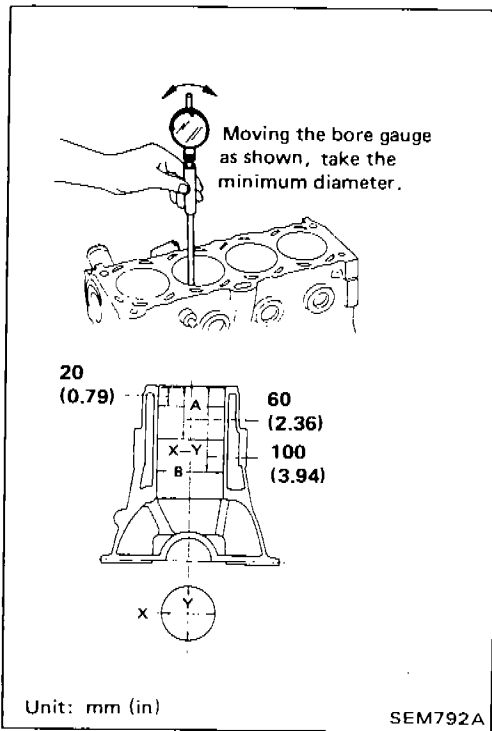

3. Measure piston skirt diameter.

Piston diameter "A":

Refer to S.D.S.

Measuring point "a" (Distance from the bottom):

14 mm (0.55 in)

4. Check that piston-to-bore clearance is within specification.

Piston-to-bore clearance "B":

0.015 - 0.035 mm (0.0006 - 0.0014 in)

5. Determine piston oversize according to amount of cylinder wear.

Oversize pistons are available for service.

Refer to S.D.S.

6. Cylinder bore size is determined by adding piston-to-bore clearance to piston diameter "A".

Rebored size calculation:

$$D = A + B - C$$

where,

D: Bored diameter

A: Piston diameter as measured

B: Piston-to-bore clearance

C: Honing allowance 0.02 mm (0.0008 in)

7. Install main bearing caps, and tighten to the specified torque to prevent distortion of cylinder bores in final assembly.

8. Cut cylinder bores.

- When any cylinder needs boring, all other cylinders must also be bored.

- Do not cut too much out of cylinder bore at a time. Cut only 0.05 mm (0.0020 in) or so in diameter at a time.

9. Hone cylinders to obtain specified piston-to-bore clearance.

10. Measure finished cylinder bore for out-of-round and taper.

- Measurement should be done after cylinder bore cools down.

CYLINDER BLOCK

Inspection (Cont'd)

CRANKSHAFT

1. Check crankshaft main and pin journals for score, wear or cracks.
2. With a micrometer, measure journals for taper and out-of-round.

Out-of-round (X - Y):

Less than 0.005 mm (0.0002 in)

Taper (A - B):

Less than 0.005 mm (0.0002 in)

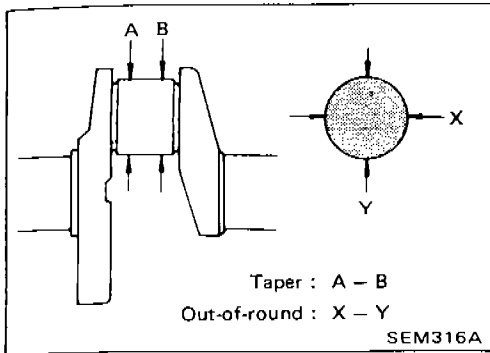

3. Measure crankshaft runout.

Runout (Total indicator reading):

Less than 0.025 mm (0.0010 in)

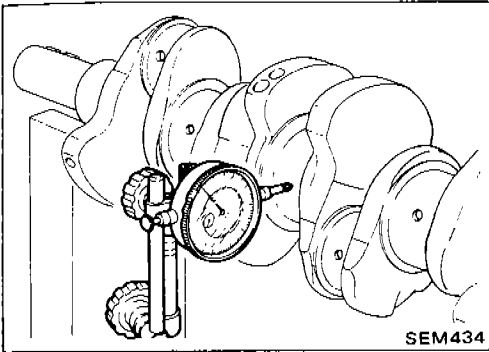

BEARING CLEARANCE

Method A (Using bore gauge & micrometer)

Main bearing

1. Set main bearings in their proper positions on cylinder block and main bearing cap.

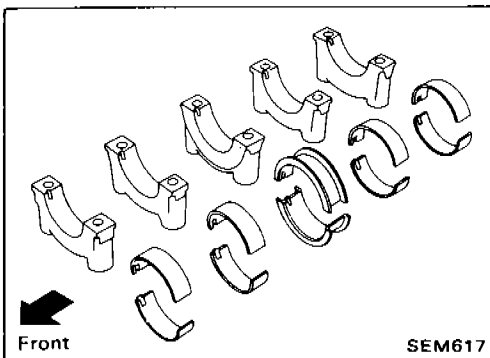

2. Install main bearing cap to cylinder block.

Tighten all bolts in correct order in two or three stages.

3. Measure inner diameter "A" of each main bearing.

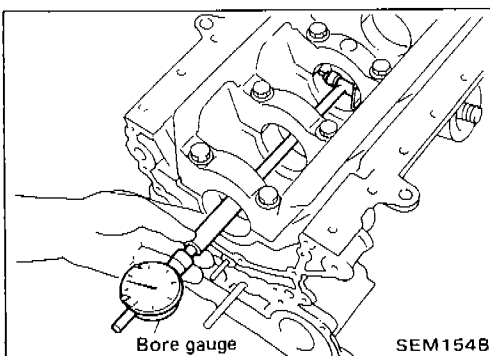

4. Measure outer diameter "Dm" of each crankshaft main journal.

5. Calculate main bearing clearance.

Main bearing clearance = A - Dm

Standard:

0.021 - 0.048 mm (0.0008 - 0.0019 in)

Limit: 0.1 mm (0.004 in)

6. If it exceeds the limit, replace bearing.

7. If clearance cannot be adjusted within the standard of any bearing, grind crankshaft journal and use undersized bearing.

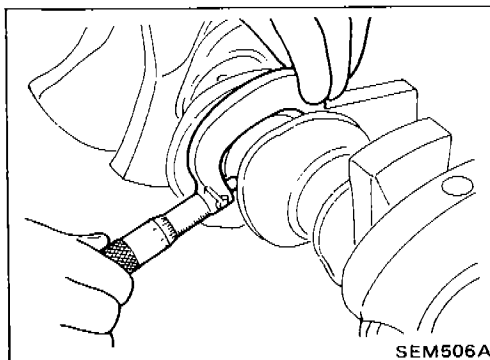

CYLINDER BLOCK

Inspection (Cont'd)

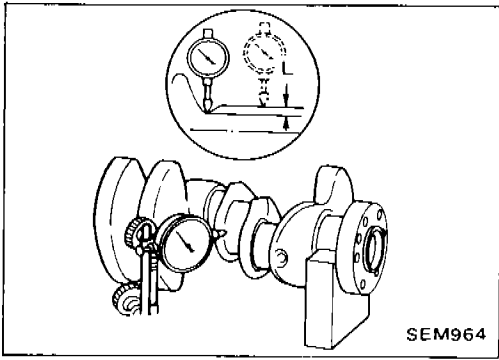

- a. When grinding crankshaft journal, confirm that "L" dimension in fillet roll is more than the specified limit.
"L": 0.1 mm (0.004 in)
- b. Refer to S.D.S. for grinding crankshaft and available service parts.

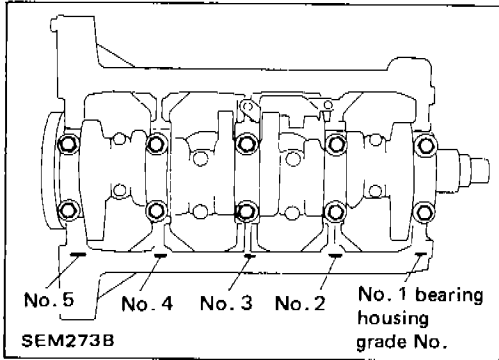

8. If crankshaft, cylinder block or main bearing is reused again, measure main bearing clearance.
If crankshaft, cylinder block and main bearings are replaced with new ones, it is necessary to select thickness of main bearings as follows:
 - a. Grade number of each cylinder block main journal is punched on the respective cylinder block.

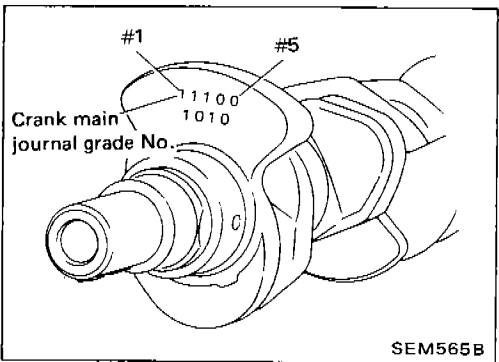

- b. Grade number of each crankshaft main journal is punched on the respective crankshaft.

- c. Select main bearing with suitable thickness according to the following table.

Main bearing grade number:

| | | | | |
|--------------------------------------|---|-----------------------------------|---|---|
| | | Main bearing housing grade number | | |
| | | 0 | 1 | 2 |
| Crankshaft main journal grade number | | Main bearing grade number | | |
| | | 0 | 1 | 2 |
| | | 1 | 2 | 3 |
| | 2 | 3 | 4 | |

For example:

Main journal grade number: 1

Crankshaft journal grade number: 2

Main bearing grade number = 1 + 2

= 3

CYLINDER BLOCK

Inspection (Cont'd)

Connecting rod bearing (Big end)

1. Install connecting rod bearing to connecting rod and cap.
2. Install connecting rod cap to connecting rod.

Tighten bolts to the specified torque.

3. Measure inner diameter "C" of each bearing.

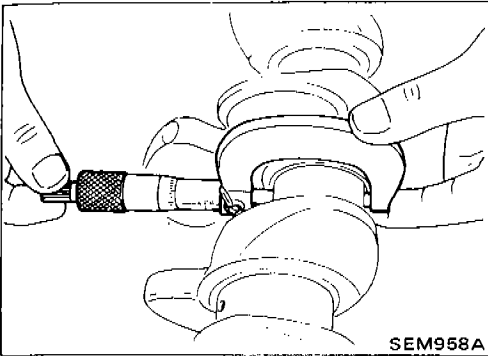
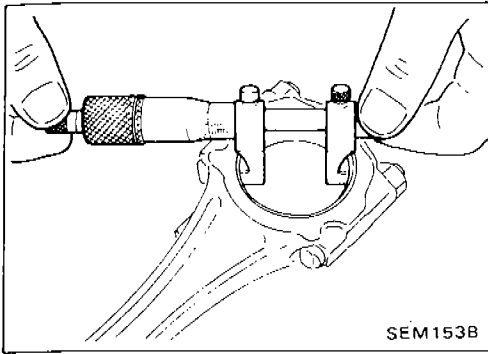

4. Measure outer diameter "Dp" of each crankshaft pin journal.
5. Calculate connecting rod bearing clearance.

$$\text{Connecting rod bearing clearance} = C - Dp$$

Standard:

0.018 - 0.045 mm (0.0007 - 0.0018 in)

Limit: 0.1 mm (0.004 in)

6. If it exceeds the limit, replace bearing.
7. If clearance cannot be adjusted within the standard of any bearing, grind crankshaft journal and use undersized bearing. Refer to step 7 of "BEARING CLEARANCE — Main bearing".

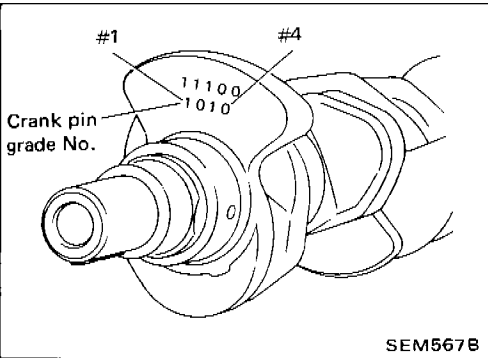

8. If bearing, crankshaft or connecting rod is replaced with a new one, select connecting rod bearing according to the following table.

Connecting rod bearing grade number:

| Crank pin grade number | Connecting rod bearing grade number |
|------------------------|-------------------------------------|
| 0 | 0 |
| 1 | 1 |
| 2 | 2 |

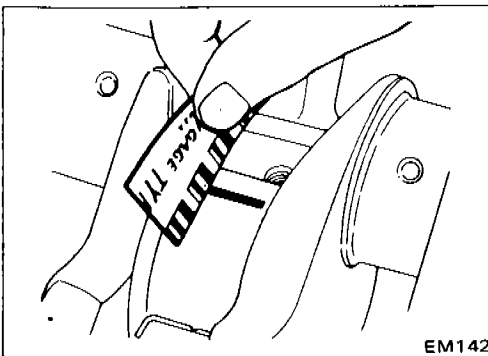

Method B (Using plastigage)

CAUTION:

- Do not turn crankshaft or connecting rod while the plastigage is being inserted.
- When bearing clearance exceeds the specified limit, ensure that the proper bearing has been installed. However, if excessive bearing clearance still exists, use thicker main bearing or undersized bearing so that the specified bearing clearance is obtained.

CYLINDER BLOCK

Inspection (Cont'd)

CONNECTING ROD BUSHING CLEARANCE (Small end)

1. Measure inner diameter "C" of bushing.

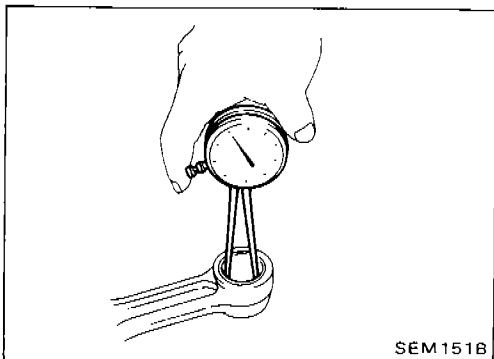

2. Measure outer diameter "Dp" of piston pin.

3. Calculate connecting rod bearing clearance.

$$C - D_p = 0.005 - 0.017 \text{ mm (0.0002 - 0.0007 in)}$$

If it exceeds the limit, replace connecting rod assembly and/or piston set with pin.

Connecting rod bushing cannot be removed from connecting rod.

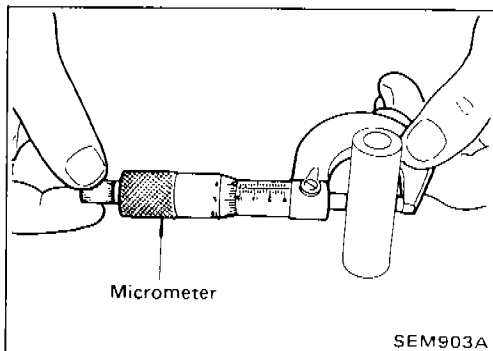

REPLACEMENT OF CONNECTING ROD BUSHING (Small end)

1. Drive in small end bushing until it is flush with end surface of rod.

Be sure to align the oil holes.

2. After driving in small end bushing, ream the bushing.

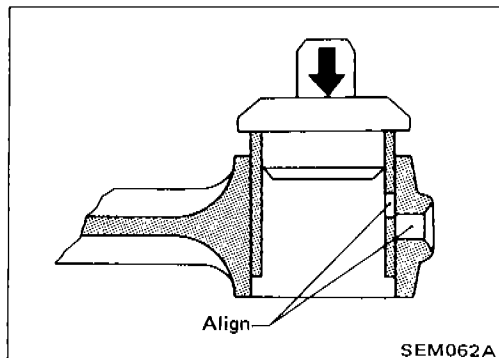

FLYWHEEL/DRIVE PLATE RUNOUT

Runout (Total indicator reading):

Less than 0.15 mm (0.0059 in)

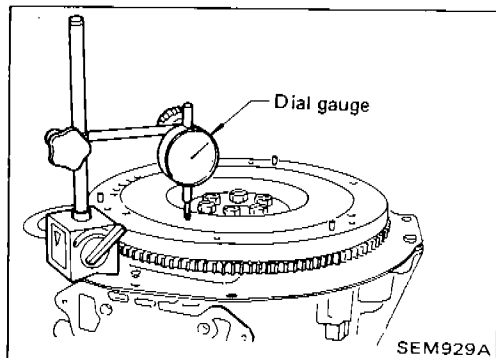

Assembly

PISTON

1. Install new snap ring on one side of piston pin hole.

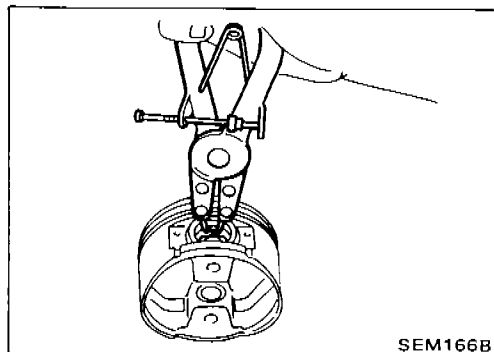

CYLINDER BLOCK

Assembly (Cont'd)

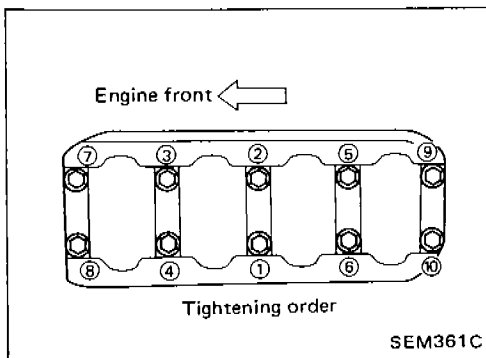
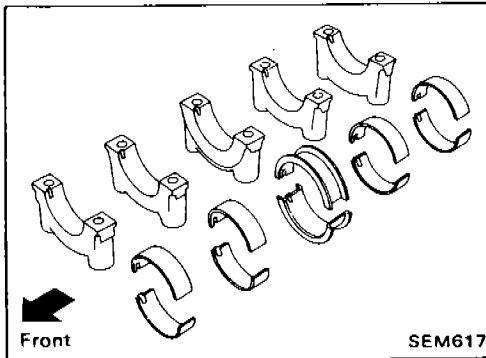
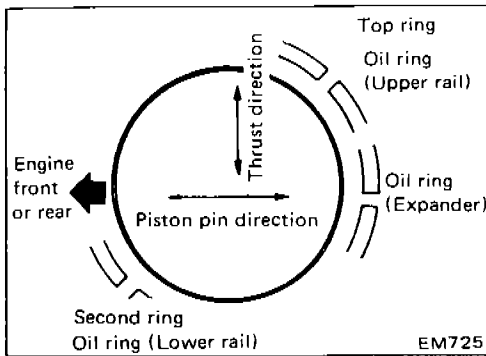
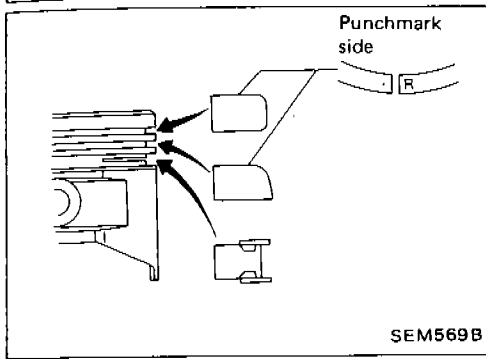
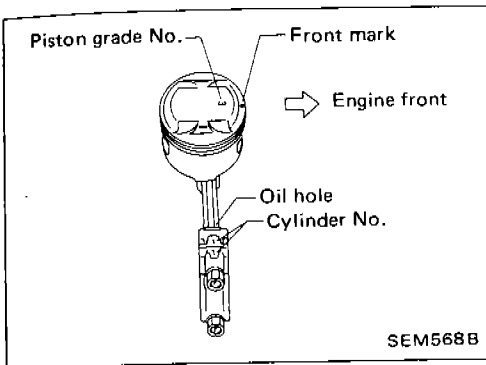

2. Heat piston to 60 to 70°C (140 to 158°F) and assemble piston, piston pin, connecting rod and new snap ring.

- Align the direction of piston and connecting rod.
- Numbers stamped on connecting rod and cap correspond to each cylinder.
- After assembly, make sure connecting rod swings smoothly.

3. Set piston rings as shown.

CRANKSHAFT

1. Set main bearings in their proper positions on cylinder block and main bearing cap.

- Confirm that correct main bearings are used. Refer to "Inspection".

2. Install crankshaft, main bearing caps and main bearing beam and tighten bolts to the specified torque.

- Prior to tightening bearing cap bolts, place bearing cap in its proper position by shifting crankshaft in the axial direction.
- Tighten bearing cap bolts gradually in two or three stages. Start with center bearing and move outward sequentially.
- After securing bearing cap bolts, make sure crankshaft turns smoothly by hand.

CYLINDER BLOCK

Assembly (Cont'd)

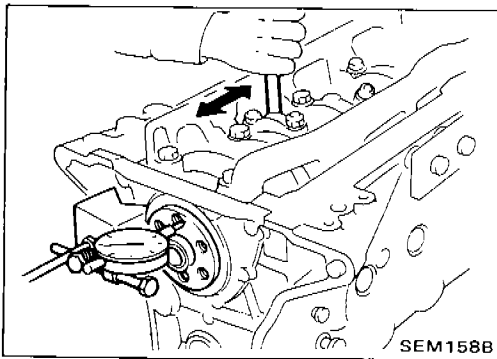

3. Measure crankshaft end play.

Crankshaft end play:

Standard

0.05 - 0.18 mm (0.0020 - 0.0071 in)

Limit

0.3 mm (0.012 in)

If beyond the limit, replace bearing with a new one.

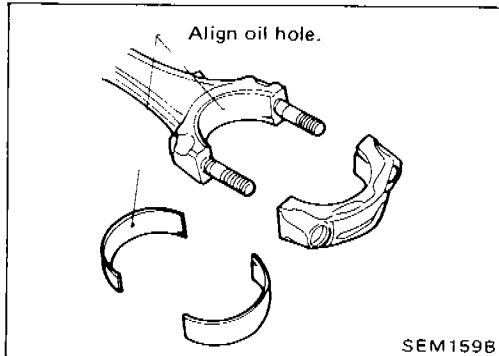

4. Install connecting rod bearings in connecting rods and connecting rod caps.

- Confirm that correct bearings are used.

Refer to "Inspection".

- Install bearings so that oil hole in connecting rod aligns with oil hole of bearing.

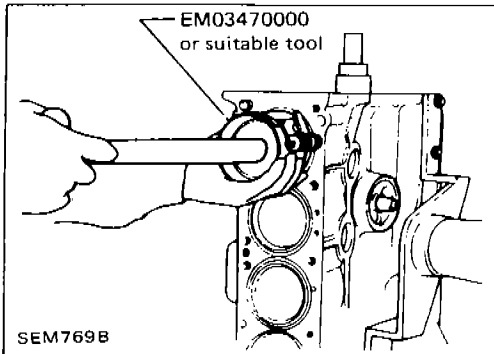

5. Install pistons with connecting rods.

a. Install them into corresponding cylinders with Tool.

- **Be careful not to scratch cylinder wall by connecting rod.**
- **Arrange so that front mark on piston head faces toward front of engine.**

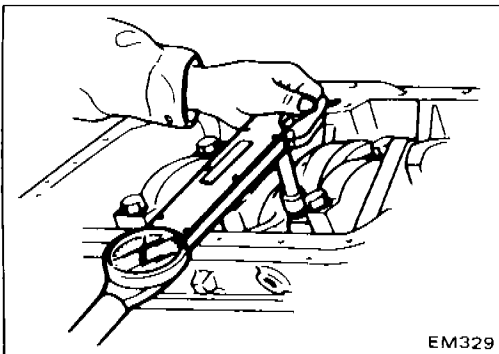

b. Install connecting rod bearing caps.

Tighten connecting rod bearing cap nuts to the specified torque.

Connecting rod bearing nut:

(1) Tighten to 14 to 16 N·m

(1.4 to 1.6 kg-m, 10 to 12 ft-lb).

(2) Tighten to 41 to 44 N·m

(4.2 to 4.5 kg-m, 30 to 33 ft-lb)

or if you have an angle wrench,
tighten bolts 60 to 65 degrees
clockwise.

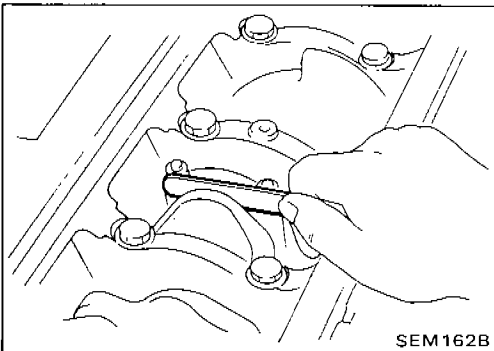

6. Measure connecting rod side clearance.

Connecting rod side clearance:

Standard

0.20 - 0.35 mm (0.0079 - 0.0138 in)

Limit

0.4 mm (0.016 in)

If beyond the limit, replace connecting rod and/or crankshaft.

CYLINDER BLOCK

Assembly (Cont'd)

REPLACING PILOT BUSHING

1. Remove pilot bushing (M/T)/pilot converter (A/T).
2. Install pilot bushing (M/T)/pilot converter (A/T).

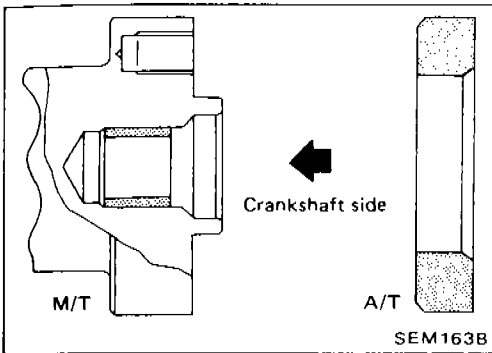
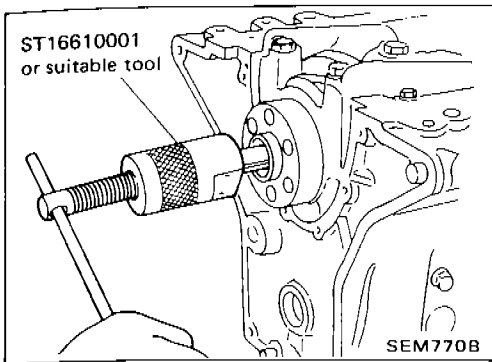

SERVICE DATA AND SPECIFICATIONS (S.D.S.)

General Specifications

| | |
|-------------------------------------------|-----------------------------|
| Engine model | CA18DET |
| Cylinder arrangement | 4, in-line |
| Displacement cm ³ (cu in) | 1,809 (110.39) |
| Bore x stroke mm (in) | 83.0 x 83.6 (3.268 x 3.291) |
| Valve arrangement | D.O.H.C. |
| Firing order | 1-3-4-2 |
| Number of piston rings | |
| Compression | 2 |
| Oil | 1 |
| Number of main bearings | 5 |
| Compression ratio | 8.5 |

Unit: kPa (bar, kg/cm², psi)/rpm

| | |
|--------------------------------------|------------------------------|
| Compression pressure | |
| Standard | 1,177 (11.77, 12.0, 171)/350 |
| Minimum | 981 (9.81, 10.0, 142)/350 |
| Differential limit between cylinders | 98 (0.98, 1.0, 14)/350 |

SERVICE DATA AND SPECIFICATIONS (S.D.S.)

Inspection and Adjustment

CYLINDER BLOCK

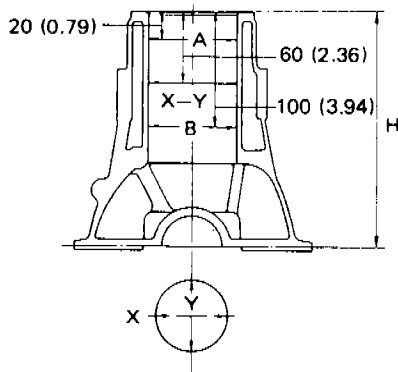

SEM528A

Unit: mm (in)

| | | Standard | Limit |
|---------------------------------------------------|----------------------|-----------------------------------|-----------------------------------|
| Distortion | | 0.03 (0.0012) | 0.1 (0.004) |
| Cylinder bore | Inner diameter | Grade 1 | 83.000 - 83.010 (3.2677 - 3.2681) |
| | | Grade 2 | 83.010 - 83.020 (3.2681 - 3.2685) |
| | | Grade 3 | 83.020 - 83.030 (3.2685 - 3.2689) |
| | | Grade 4 | 83.030 - 83.040 (3.2689 - 3.2693) |
| | | Grade 5 | 83.040 - 83.050 (3.2693 - 3.2697) |
| | Out-of-round (X - Y) | Less than 0.015 (0.0006) | — |
| | Taper (A - B) | Less than 0.010 (0.0004) | — |
| Difference in inner diameter between cylinders | | Less than 0.05 (0.0020) | 0.2 (0.008) |
| Piston-to-cylinder clearance | | 0.015 - 0.035 (0.0006 - 0.0014) | — |
| Cylinder block height (From crankshaft center) | | 204.75 - 204.85 (8.0610 - 8.0649) | 0.2 (0.008)** |

* Wear limit

** Total amount of cylinder head resurfacing and cylinder block resurfacing

SERVICE DATA AND SPECIFICATIONS (S.D.S.)

Inspection and Adjustment (Cont'd)

CYLINDER HEAD

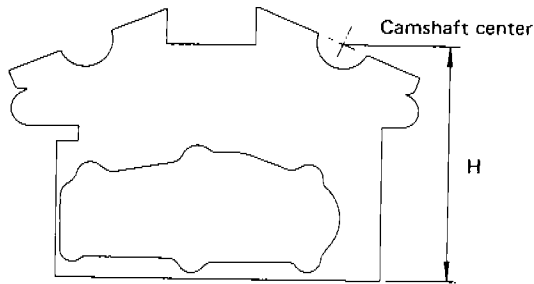

SEM570B

Unit: mm (in)

| | Standard | Limit |
|--------------------|----------------------------------|--------------|
| Height (H) | 125.9 - 126.1 (4.957 - 4.965) | 0.2 (0.008)* |
| Surface distortion | 0.03 (0.0012) | 0.1 (0.004) |

* Total amount of cylinder head resurfacing and cylinder block resurfacing

VALVE GUIDE

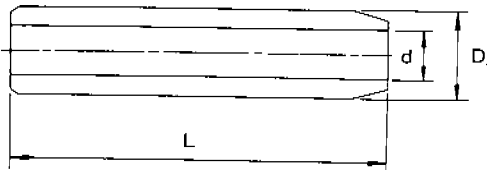

SEM571B

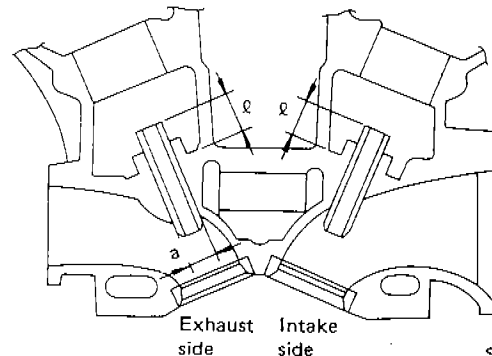

SEM572B

Unit: mm (in)

| | Standard | | Service | | Limit |
|---------------------------------------|------------------------------------|------------------------------------|------------------------------------|------------------------------------|-------------|
| | Intake | Exhaust | Intake | Exhaust | |
| Length (L) | 40.1 (1.579) | 43.1 (1.697) | 40.1 (1.579) | 43.1 (1.697) | — |
| Outer diameter (D) | 10.023 - 10.034 (0.3946 - 0.3950) | | 10.223 - 10.234 (0.4025 - 0.4029) | | — |
| Inner diameter (d) (Finished size) | 6.000 - 6.018 (0.2362 - 0.2369) | | | | — |
| Cylinder head hole diameter (a) | 9.975 - 9.996 (0.3927 - 0.3935) | | 10.175 - 10.196 (0.4006 - 0.4014) | | — |
| Interference fit | 0.027 - 0.059 (0.0011 - 0.0023) | | | | — |
| Stem to guide clearance | 0.020 - 0.053 (0.0008 - 0.0021) | 0.040 - 0.073 (0.0016 - 0.0029) | 0.020 - 0.053 (0.0008 - 0.0021) | 0.040 - 0.073 (0.0016 - 0.0029) | 0.1 (0.004) |
| Tapping length (r) | 15.1 - 15.3 (0.594 - 0.602) | | | | — |

SERVICE DATA AND SPECIFICATIONS (S.D.S.)

Inspection and Adjustment (Cont'd)

VALVE SEAT

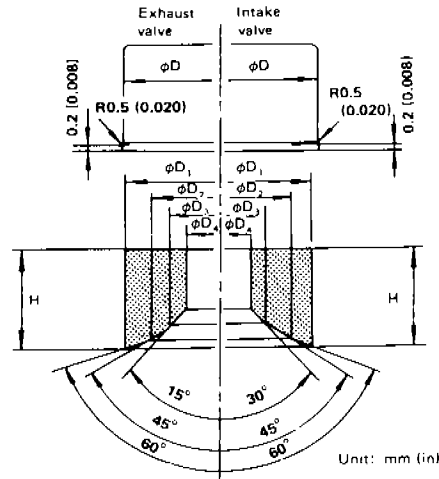

SEM573B

Unit: mm (in)

| | Standard | | Service | |
|----------------------------------------|--------------------------------------|--------------------------------------|--------------------------------------|--------------------------------------|
| | Intake | Exhaust | Intake | Exhaust |
| Cylinder head seat recess diameter (D) | 36.000 - 36.016 (1.4173 - 1.4179) | 30.000 - 30.016 (1.1811 - 1.1817) | 36.500 - 36.516 (1.4370 - 1.4376) | 30.500 - 30.516 (1.2008 - 1.2014) |
| Valve seat outer diameter (D_1) | 36.097 - 36.113 (1.4211 - 1.4218) | 30.080 - 30.096 (1.1842 - 1.1849) | 36.597 - 36.613 (1.4408 - 1.4415) | 30.580 - 30.596 (1.2039 - 1.2046) |
| Face outer diameter (D_2) | 33.6 - 33.8 (1.323 - 1.331) | 27.4 - 27.6 (1.079 - 1.087) | 33.6 - 33.8 (1.323 - 1.331) | 27.4 - 27.6 (1.079 - 1.087) |
| Face inner diameter (D_3) | 31.5 (1.240) | 24.9 (0.980) | 31.5 (1.240) | 24.9 (0.980) |
| Valve seat inner diameter (D_4) | 29.85 - 30.15 (1.1752 - 1.1870) | 22.85 - 23.15 (0.8996 - 0.9114) | 29.9 - 30.1 (1.177 - 1.185) | 22.85 - 23.15 (0.8996 - 0.9114) |
| Height (H) | 5.9 - 6.0 (0.232 - 0.236) | 6.4 - 6.5 (0.252 - 0.256) | 5.35 - 5.45 (0.2106 - 0.2146) | 5.75 - 5.85 (0.2264 - 0.2303) |

SERVICE DATA AND SPECIFICATIONS (S.D.S.)

Inspection and Adjustment (Cont'd)

VALVE

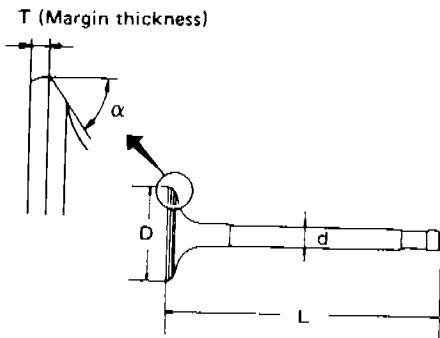

SEM188A

HYDRAULIC VALVE LIFTER

Unit: mm (in)

| | |
|----------------------------|--------------------------------------|
| Valve lifter diameter | 30.955 - 30.965 (1.2187 - 1.2191) |
| Lifter guide bore diameter | 31.000 - 31.013 (1.2205 - 1.2210) |

Unit: mm (in)

| | | Standard | Limit |
|-------------------------|-----|------------------------------------|-------------|
| Valve head diameter (D) | In. | 34.0 - 34.2 (1.339 - 1.346) | — |
| | Ex. | 28.0 - 28.2 (1.102 - 1.110) | — |
| Valve length (L) | In. | 88.8 - 89.0 (3.496 - 3.504) | — |
| | Ex. | 89.2 - 89.4 (3.512 - 3.520) | — |
| Valve stem diameter (d) | In. | 5.965 - 5.980 (0.2348 - 0.2354) | — |
| | Ex. | 5.945 - 5.960 (0.2341 - 0.2346) | — |
| Valve face angle (α) | In. | 45°30' | — |
| | Ex. | 45°30' | — |
| Valve head margin (T) | In. | 1.3 (0.051) | 0.5 (0.020) |
| | Ex. | 1.5 (0.059) | |

VALVE SPRING

Unit: mm (in)

| | | Standard | Limit |
|----------------------------------------|--|-----------------|-------------|
| Free height (H) | | 43.1 (1.697) | — |
| Spring constant N/mm (kg/mm, lb/in) | | 28.4 (2.9, 162) | — |
| Out-of-square (S) | | — | 1.8 (0.071) |

SERVICE DATA AND SPECIFICATIONS (S.D.S.)

Inspection and Adjustment (Cont'd)

CAMSHAFT AND CAMSHAFT BEARING

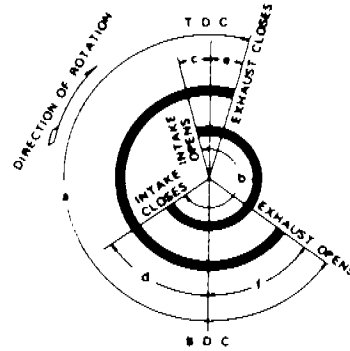
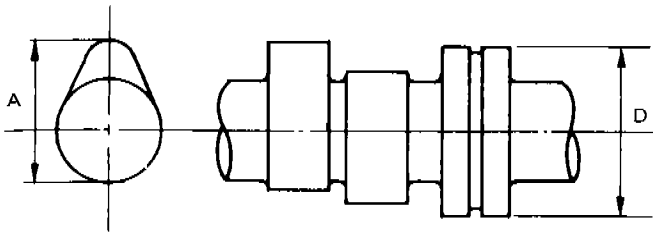

SEM568A

EM120

Unit: mm (in)

| | | Standard | Limit |
|----------------------------------------|-----|-----------------------------------|---------------|
| Cam height (A) | In. | 39.785 - 39.815 (1.5663 - 1.5675) | — |
| | Ex. | 40.485 - 40.515 (1.5939 - 1.5951) | — |
| Valve lift | In. | 7.8 (0.307) | — |
| | Ex. | 8.5 (0.335) | — |
| Wear limit of cam height | | — | 0.2 (0.008) |
| Camshaft journal to bearing clearance | | 0.045 - 0.090 (0.0018 - 0.0035) | 0.15 (0.0059) |
| Inner diameter of camshaft bearing | | 28.000 - 28.025 (1.1024 - 1.1033) | — |
| Outer diameter of camshaft journal (D) | | 27.935 - 27.955 (1.0998 - 1.1006) | — |
| Camshaft runout | | — | 0.05 (0.0020) |
| Camshaft end play | | 0.07 - 0.15 (0.0028 - 0.0059) | 0.2 (0.008) |
| Valve timing (Degree on crankshaft) | a | 248 | — |
| | b | 240 | — |
| | c | 0 | — |
| | d | 60 | — |
| | e | 9 | — |
| | f | 59 | — |

SERVICE DATA AND SPECIFICATIONS (S.D.S.)

Inspection and Adjustment (Cont'd)

PISTON, PISTON RING AND PISTON PIN Piston

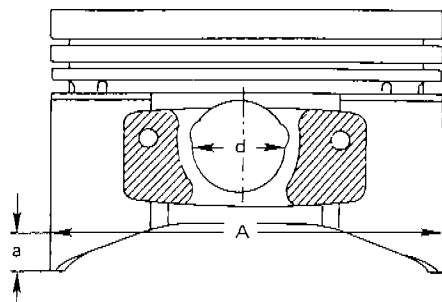

SEM493C

Unit: mm (in)

| | | | |
|-----------------------------------|-----------------------------------|----------------|--------------------------------------|
| Piston skirt diameter (A) | Service (Standard) | Grade No. 1 | 82.975 - 82.985 (3.2667 - 3.2671) |
| | | Grade No. 2 | 82.985 - 82.995 (3.2671 - 3.2675) |
| | | Grade No. 3 | 82.995 - 83.005 (3.2675 - 3.2679) |
| | | Grade No. 4 | 83.005 - 83.015 (3.2679 - 3.2683) |
| | | Grade No. 5 | 83.015 - 83.025 (3.2683 - 3.2687) |
| | Service (Oversize) | 0.5 (0.020) | 83.475 - 83.525 (3.2864 - 3.2884) |
| | | 1.0 (0.039) | 83.975 - 84.025 (3.3061 - 3.3081) |
| Dimension (a) | Approximately 14 (0.55) | | |
| Piston pin hole diameter (d) | 19.987 - 19.999 (0.7869 - 0.7874) | | |
| Piston-to-cylinder bore clearance | 0.015 - 0.035 (0.0006 - 0.0014) | | |

Piston pin

Unit: mm (in)

| | |
|-------------------------------------------------------------|--------------------------------------|
| Piston pin outer diameter | 19.989 - 20.001 (0.7870 - 0.7874) |
| Interference fit of piston pin to piston pin hole clearance | 0 - 0.004 (0 - 0.0002) |
| Piston pin to connecting rod bearing clearance | 0.005 - 0.017 (0.0002 - 0.0007) |

Piston ring

Unit: mm (in)

| | | Standard | Limit |
|----------------|-----------------|------------------------------------|-------------|
| Side clearance | Top | 0.040 - 0.073 (0.0016 - 0.0029) | 0.1 (0.004) |
| | 2nd | 0.030 - 0.063 (0.0012 - 0.0025) | 0.1 (0.004) |
| End gap | Top | 0.25 - 0.42 (0.0098 - 0.0165) | 1.0 (0.039) |
| | 2nd | 0.38 - 0.64 (0.0150 - 0.0252) | 1.0 (0.039) |
| | Oil (rail ring) | 0.20 - 0.76 (0.0079 - 0.0299) | 1.0 (0.039) |

SERVICE DATA AND SPECIFICATIONS (S.D.S.)

Inspection and Adjustment (Cont'd)

CONNECTING ROD

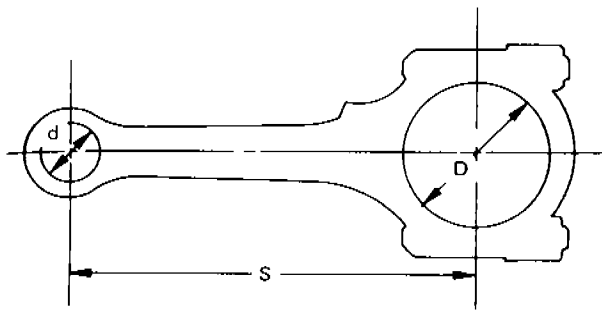

SEM570A

Unit: mm (in)

| | Standard | Limit |
|-----------------------------------------|--------------------------------------|-------------|
| Center distance (S) | 132.95 - 133.05 (5.2342 - 5.2382) | — |
| Twist per 100 mm (3.94 in)] | — | 0.1 (0.004) |
| Distortion per 100 mm (3.94 in)] | — | 0.1 (0.004) |
| Crank pin bore diameter * | 22.987 - 23.000 (0.9050 - 0.9055) | — |
| Clearance between piston and bearing | 0.005 - 0.017 (0.0002 - 0.0007) | — |
| Crank pin bore diameter * | 48.000 - 48.013 (1.8898 - 1.8903) | — |
| Clearance between crank and bearing | 0.018 - 0.045 (0.0007 - 0.0018) | — |
| End play | — | 0.4 (0.016) |

*Without bearing

SERVICE DATA AND SPECIFICATIONS (S.D.S.)

Inspection and Adjustment (Cont'd)

CRANKSHAFT

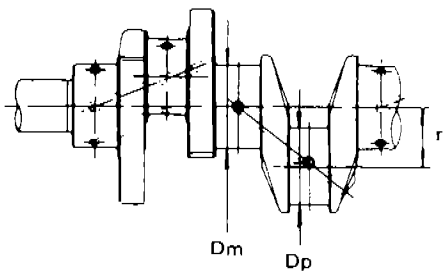

EM737

Out-of-round X - Y
Taper A - B

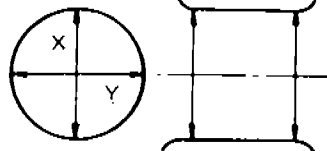

EM715

Unit: mm (in)

| | | |
|-----------------------------------------|-----------------------------------|----------------|
| Main journal diameter (D_m) | 52.951 - 52.975 (2.0847 - 2.0856) | |
| Pin journal diameter (D_p) | 44.954 - 44.974 (1.7698 - 1.7706) | |
| Center distance (r) | 41.77 - 41.83 (1.6445 - 1.6468) | |
| | Standard | Limit |
| Taper of journal and pin (A - B) | — | 0.005 (0.0002) |
| Out-of-round of journal and pin (X - Y) | — | 0.005 (0.0002) |
| Runout [T.I.R.] * | — | 0.025 (0.0010) |
| Free end play | 0.05 - 0.18 (0.0020 - 0.0071) | 0.3 (0.012) |

* Total indicator reading

SERVICE DATA AND SPECIFICATIONS (S.D.S.)

Inspection and Adjustment (Cont'd)

BEARING CLEARANCE

Unit: mm (in)

| | Standard | Limit |
|----------------------------------|------------------------------------|-------------|
| Main bearing clearance | 0.021 - 0.048 (0.0008 - 0.0019) | 0.1 (0.004) |
| Connecting rod bearing clearance | 0.018 - 0.045 (0.0007 - 0.0018) | 0.1 (0.004) |

AVAILABLE CONNECTING ROD BEARING

Standard

| Grade number | Thickness mm (in) | Identification color |
|--------------|------------------------------------|----------------------|
| 0 | 1.501 - 1.504 (0.0591 - 0.0592) | — |
| 1 | 1.504 - 1.507 (0.0592 - 0.0593) | Brown |
| 2 | 1.507 - 1.510 (0.0593 - 0.0594) | Green |

AVAILABLE MAIN BEARING

Standard

| Grade number | Thickness mm (in) | Identification color |
|--------------|------------------------------------|----------------------|
| 0 | 1.825 - 1.829 (0.0719 - 0.0720) | Black |
| 1 | 1.829 - 1.833 (0.0720 - 0.0722) | Brown |
| 2 | 1.833 - 1.837 (0.0722 - 0.0723) | Green |
| 3 | 1.837 - 1.841 (0.0723 - 0.0725) | Yellow |
| 4 | 1.841 - 1.845 (0.0725 - 0.0726) | Blue |

Undersize (service)

Unit: mm (in)

| | Thickness | Crank pin journal diameter "Dp" |
|------------------|------------------------------------|---------------------------------------------------------|
| 0.08 (0.0031) | 1.540 - 1.548 (0.0606 - 0.0609) | Grind so that bearing clearance is the specified value. |
| 0.12 (0.0047) | 1.560 - 1.568 (0.0614 - 0.0617) | |
| 0.25 (0.0098) | 1.625 - 1.633 (0.0640 - 0.0643) | |

Undersize (service)

Unit: mm (in)

| | Thickness | Main journal diameter "Dm" |
|------------------|------------------------------------|---------------------------------------------------------|
| 0.25 (0.0098) | 1.947 - 1.960 (0.0767 - 0.0772) | Grind so that bearing clearance is the specified value. |

MISCELLANEOUS COMPONENTS

Unit: mm (in)

| | |
|-------------------------------------|-------------------------|
| Camshaft sprocket runout [T.I.R.] * | Less than 0.1 (0.004) |
| Flywheel runout [T.I.R.] * | Less than 0.15 (0.0059) |

* Total indicator reading

TURBOCHARGER

| | |
|------------------------------------|-------------------------------------------------------------------------------------------------|
| By-pass valve controller diaphragm | 0.38 mm (0.0150 in)/ 83.3 - 88.6 kPa (833 - 886 mbar, 625 - 665 mmHg, 24.61 - 26.18 inHg) |
| Play | 0.013 - 0.097 mm (0.0005 - 0.0038 in) |

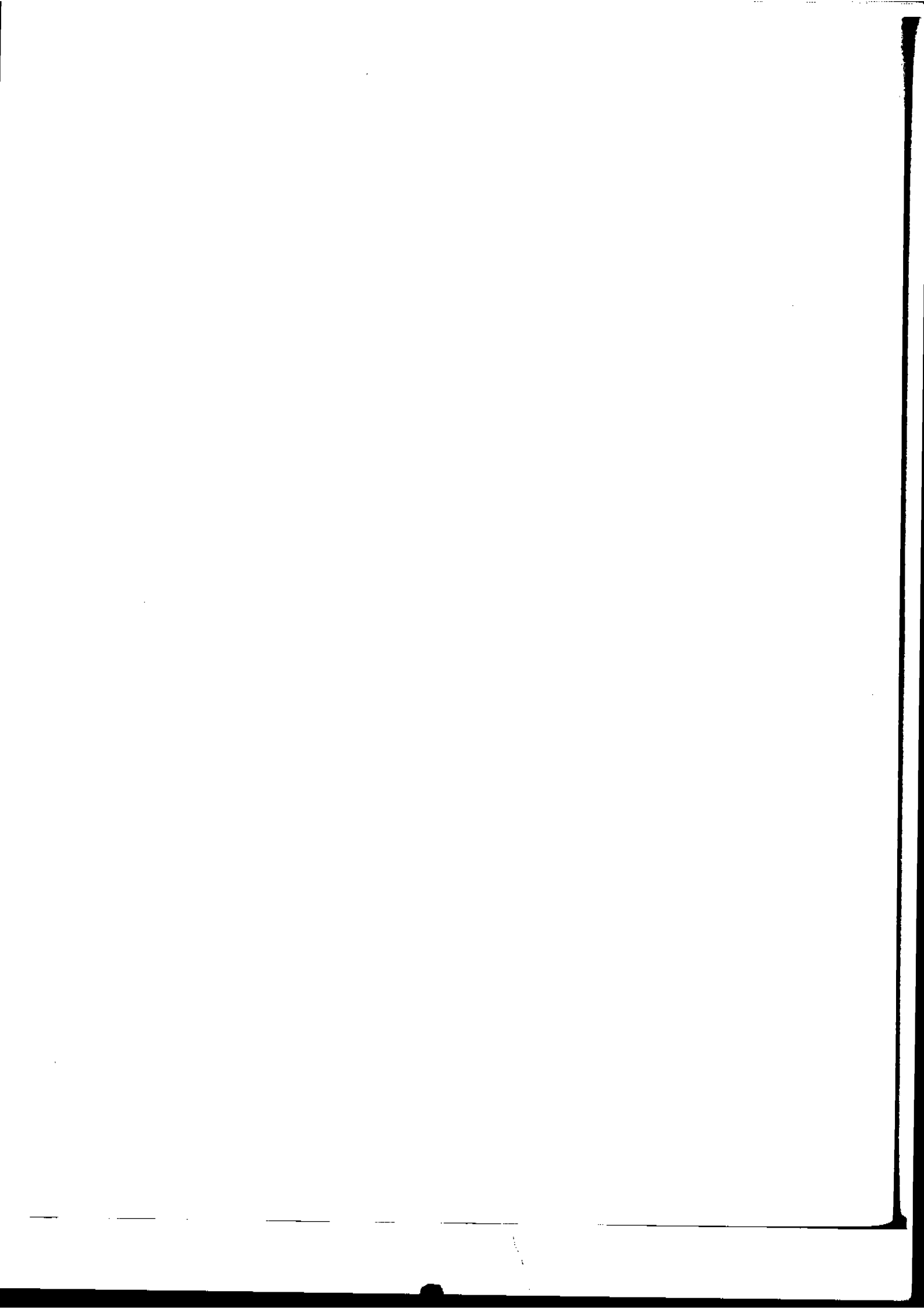

ENGINE LUBRICATION & COOLING SYSTEMS

SECTION **LC**



LC

CONTENTS

| | |
|------------------------------------------------|-------|
| PREPARATION | LC- 2 |
| ENGINE LUBRICATION SYSTEM | LC- 3 |
| ENGINE COOLING SYSTEM | LC- 8 |
| SERVICE DATA AND SPECIFICATIONS (S.D.S.) | LC-15 |

PREPARATION

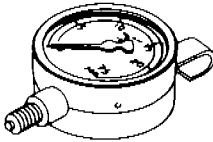
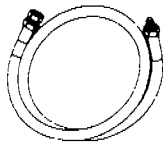
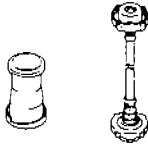
SPECIAL SERVICE TOOLS

| Tool number Tool name | Description |
|-------------------------------------------|----------------------------------------------------------------------------------------------------------------------------------------|
| ST25051001 Oil pressure gauge |  |
| ST25052000 Hose |  Adapting oil pressure gauge to cylinder block |
| EG17650301 Radiator cap tester adapter |  Adapting radiator cap tester to radiator filler neck |
| KV99103510 Radiator plate pliers A |  Installing radiator upper and lower tanks |
| KV99103520 Radiator plate pliers B |  Removing radiator upper and lower tanks |

ENGINE LUBRICATION SYSTEM

Lubrication Circuit

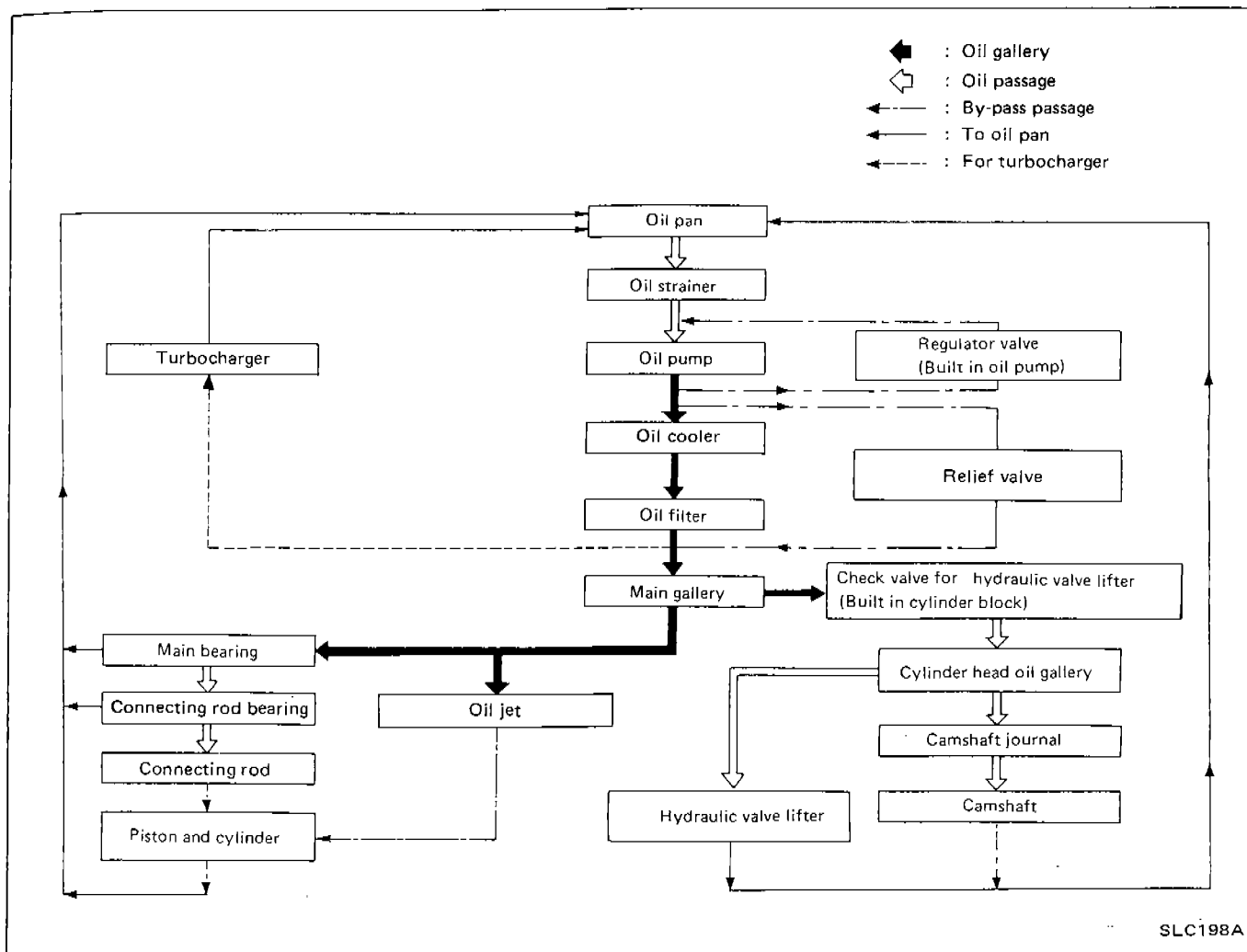

Oil Pressure Check

WARNING:

- Be careful not to burn yourself, as the engine and oil may be hot.
- Oil pressure check should be done in "Neutral" gear position.

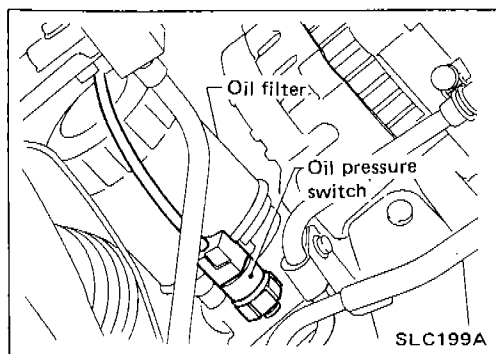

1. Check oil level.
2. Remove oil pressure switch.

ENGINE LUBRICATION SYSTEM

Oil Pressure Check (Cont'd)

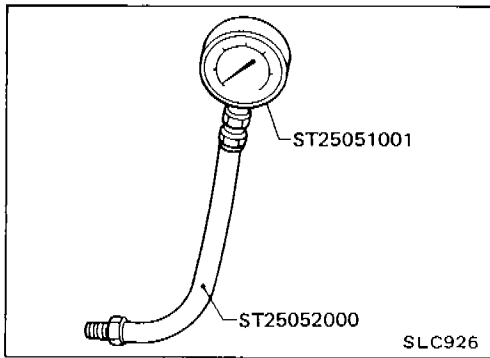

3. Install pressure gauge.
4. Start engine and warm it up to normal operating temperature.
5. Check oil pressure with engine running under no-load.

| Engine rpm | Approximate discharge pressure kPa (bar, kg/cm ² , psi) |
|---------------------|-----------------------------------------------------------------------------|
| Idle speed 3,000 | More than 78 (0.78, 0.8, 11) 353 - 412 (3.53 - 4.12, 3.6 - 4.2, 51 - 60) |

If difference is extreme, check oil passage and oil pump for oil leaks.

6. Install oil pressure switch with sealant.

Use proper liquid sealant.

Oil pressure switch:

⌚: 10 - 16 N·m (1.0 - 1.6 kg-m, 7 - 12 ft-lb)

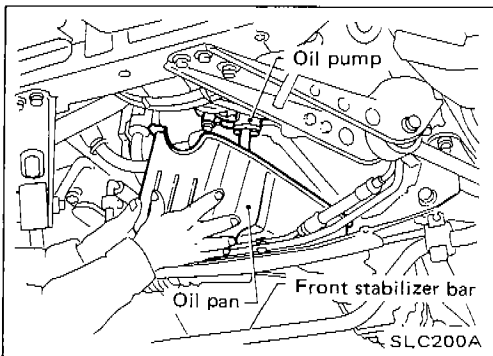

Oil Pump

REMOVAL AND INSTALLATION

1. Remove drive belts.
2. Remove timing belt covers and timing belt.
3. Remove front stabilizer bar.
4. Loosen front engine mounting nuts. (Do not loosen nuts completely.)
5. Lift up engine slightly using engine slings.
6. Remove oil pan.
7. Remove oil pump assembly with oil strainer.
8. Installation is in reverse order of removal.

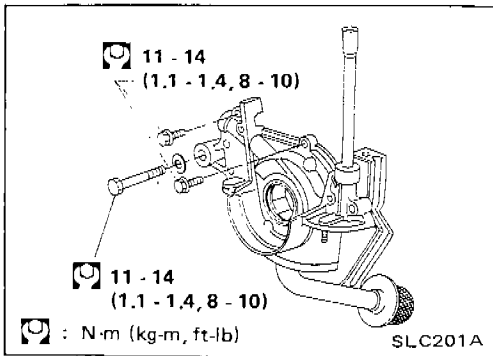

ENGINE LUBRICATION SYSTEM

Oil Pump (Cont'd)

DISASSEMBLY AND ASSEMBLY

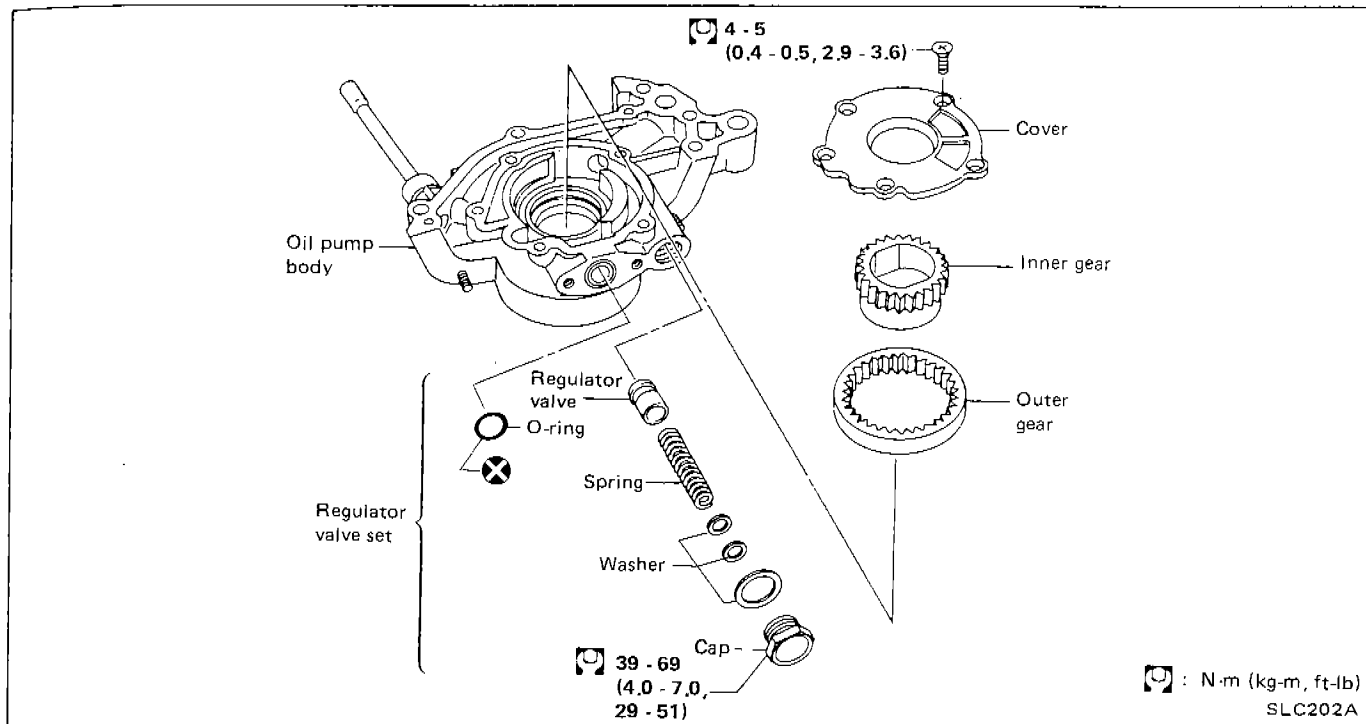

- When installing oil pump, apply engine oil to inner and outer gear.
- Be sure that O-ring is properly fitted.

INSPECTION

Using a feeler gauge, check the following clearances.

Unit: mm (in)

| | |
|------------------------------------|-------------------------------|
| Body to outer gear clearance ① | 0.11 - 0.20 (0.0043 - 0.0079) |
| Inner gear to crescent clearance ② | 0.15 - 0.26 (0.0059 - 0.0102) |
| Outer gear to crescent clearance ③ | 0.21 - 0.32 (0.0083 - 0.0126) |
| Housing to inner gear clearance ④ | 0.05 - 0.09 (0.0020 - 0.0035) |
| Housing to outer gear clearance ⑤ | 0.05 - 0.11 (0.0020 - 0.0043) |

If it exceeds the limit, replace gear set or entire oil pump assembly.

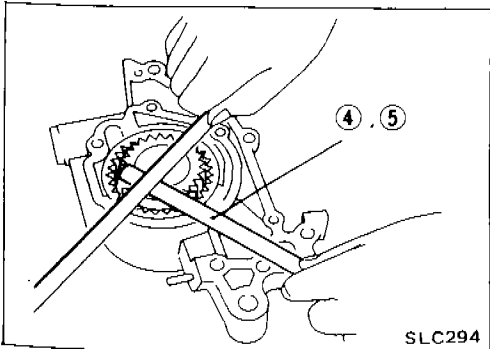
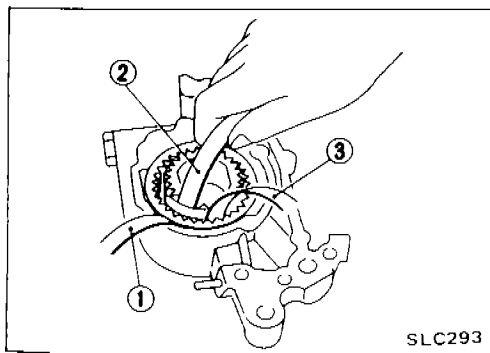

ENGINE LUBRICATION SYSTEM

Oil Pump (Cont'd)

REGULATOR VALVE INSPECTION

1. Visually inspect components for wear and damage.
 2. Check oil pressure regulator valve sliding surface and valve spring.
 3. Coat regulator valve with engine oil and check that it falls smoothly into the valve hole by its own weight.
- If damaged, replace regulator valve set or oil pump assembly.

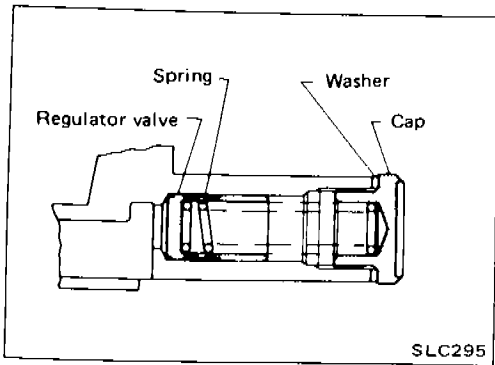

OIL PRESSURE RELIEF VALVE INSPECTION

Inspect oil pressure relief valve for movement, cracks and breaks by pushing the ball. If replacement is necessary, remove valve by prying it out with a suitable tool. Install a new valve in place by tapping it.

Oil Jet

INSPECTION (For piston)

1. Blow through outlet of oil jet and make sure that air comes out of inlet.
2. Push cut-off valve of oil jet bolt with a clean resin or brass rod and make sure that cut-off valve moves smoothly with proper repulsion.

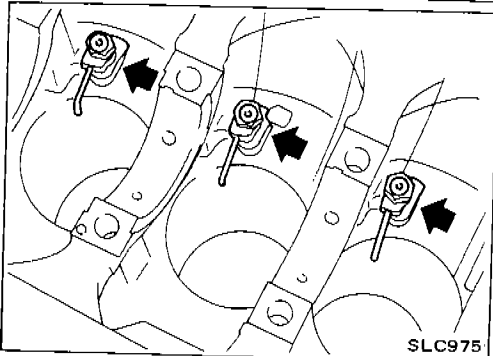
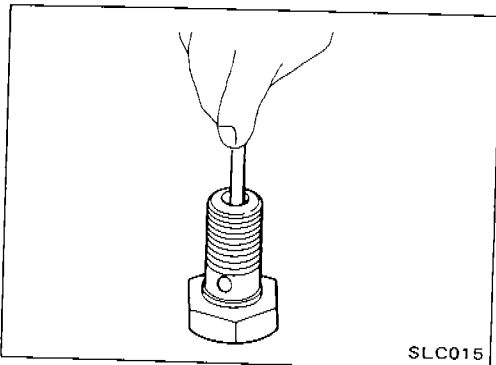

When installing oil jet, align oil jet's boss with hole on cylinder block.

Oil jet bolt:

⌘: 29 - 39 N·m (3.0 - 4.0 kg·m, 22 - 29 ft·lb)

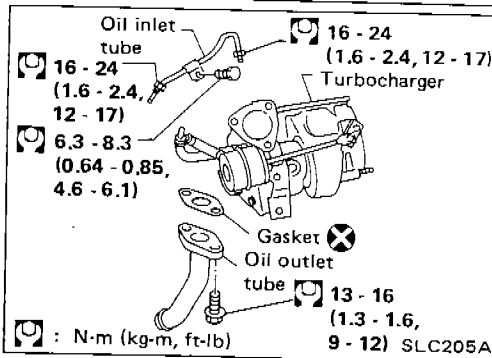

Turbocharger

- Before removing water tube, drain coolant first.
- After installation, run engine for a few minutes and check for leaks.

ENGINE LUBRICATION SYSTEM

Oil Cooler

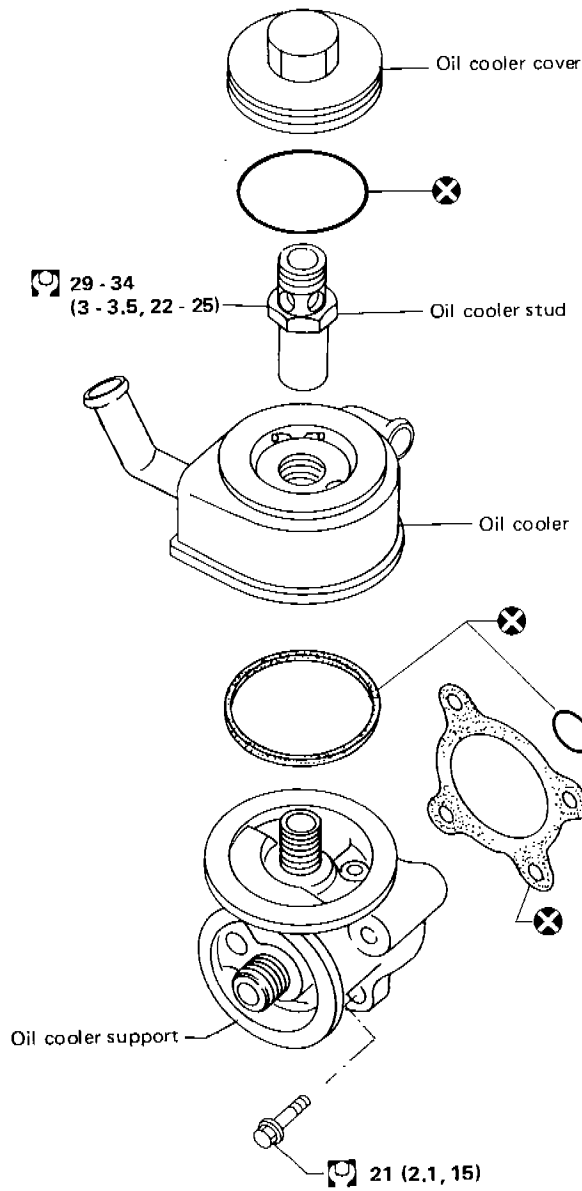

⊗ : N·m (kg-m, ft-lb)

⊗ 21 (2.1, 15)

SLC207A

INSPECTION

1. Check oil cooler element and housing for cracks.
 2. Check oil cooler for clogging by blowing through coolant inlet.
- Replace it if necessary.

ENGINE COOLING SYSTEM

Cooling Circuit

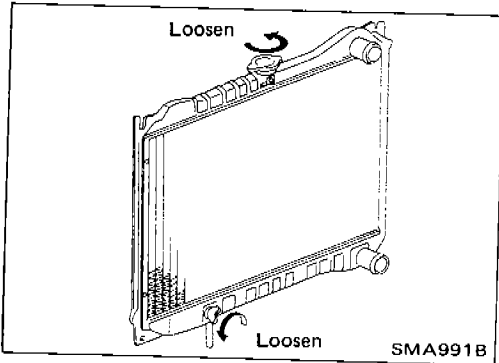
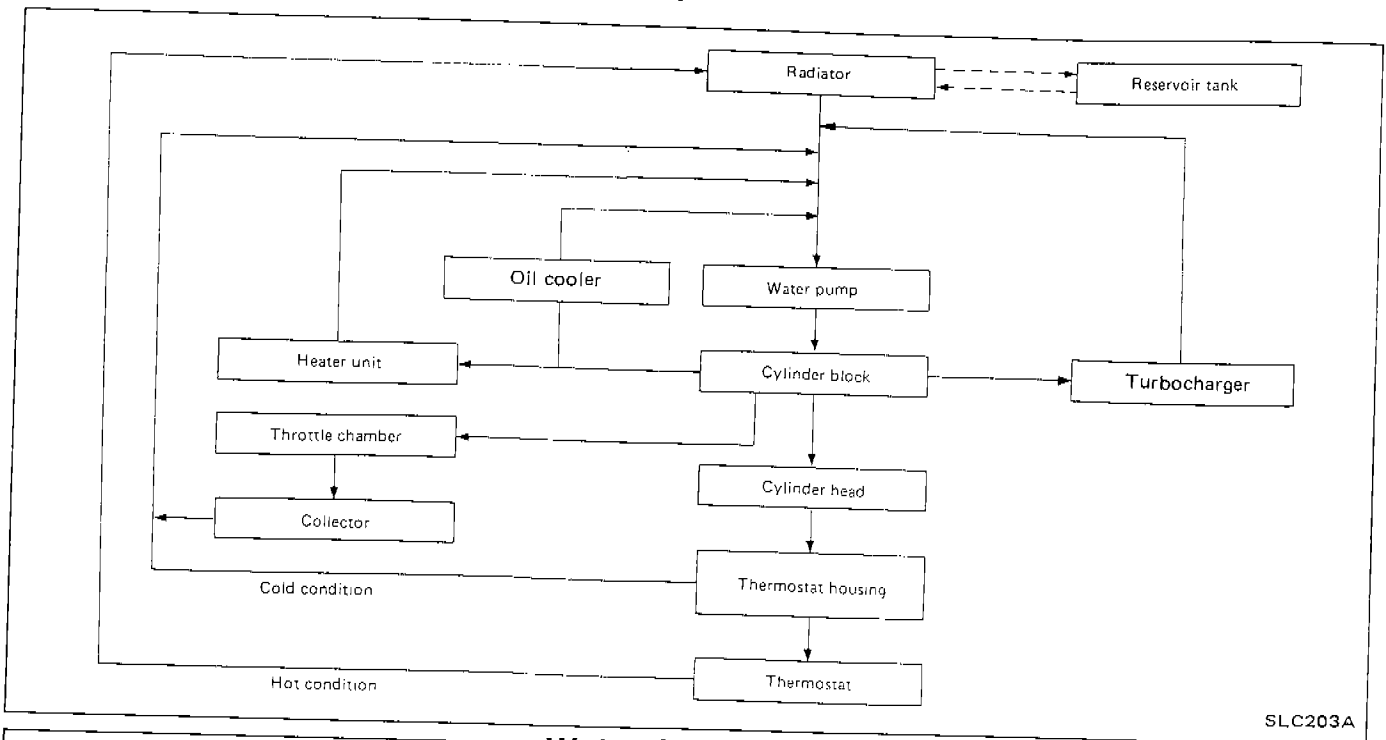

Water Pump

REMOVAL AND INSTALLATION

1. Drain coolant from radiator.

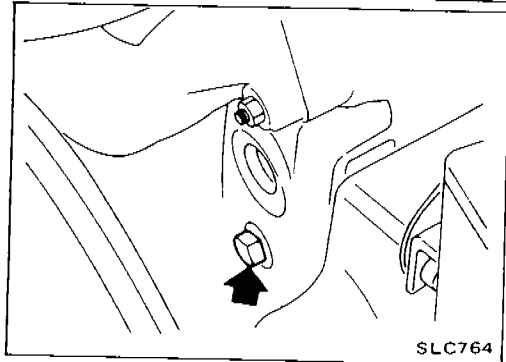

2. Remove cylinder block drain plug located at left rear of cylinder block and drain coolant.

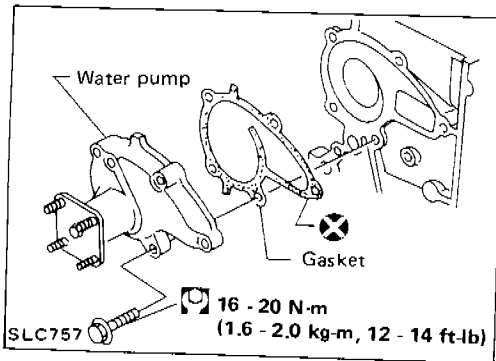

CAUTION:

- When removing water pump assembly, be careful not to get coolant on timing belt.
- Water pump cannot be disassembled and should be replaced as a unit.
- After installing water pump, connect hose and clamp securely, then check for leaks using radiator cap tester.

ENGINE COOLING SYSTEM

Water Pump (Cont'd)

INSPECTION

1. Check for badly rusted or corroded body assembly and vane.
2. Check for rough operation due to excessive end play.

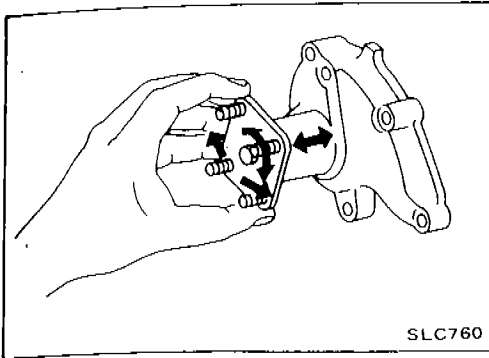

Thermostat

INSPECTION

1. Check for valve seating condition at ordinary temperatures. It should seat tightly.

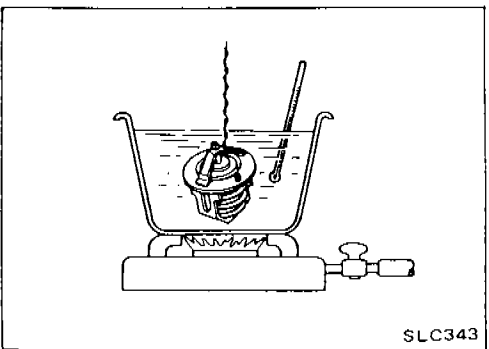
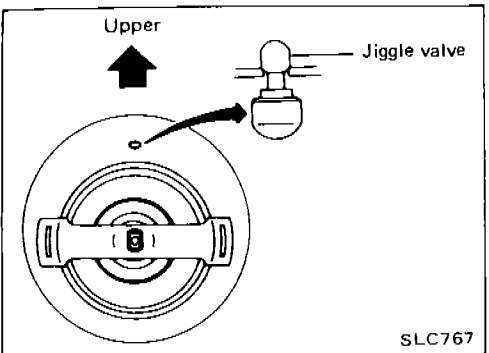
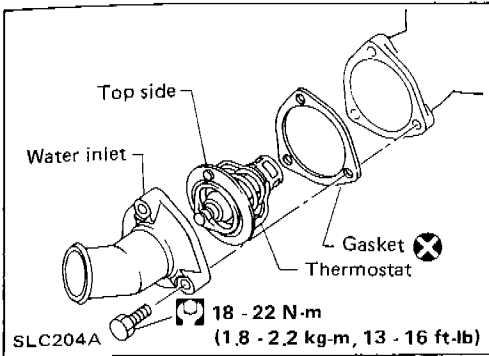

2. Check valve opening temperature and maximum valve lift.

| | Standard | Cold type | Hot type* |
|--------------------------------------|--------------------|---------------------|--------------------|
| Valve opening temperature °C (°F) | 82 (180) | 88 (190) | 76.5 (170) |
| Max. valve lift mm/°C (in/°F) | 8/95 (0.31/203) | 8/100 (0.31/212) | 8/90 (0.31/194) |

*For general areas only

3. Then check if valve closes at 5°C (9°F) below valve opening temperature.

- After installation, run engine for a few minutes, and check for leaks.

ENGINE COOLING SYSTEM

Radiator

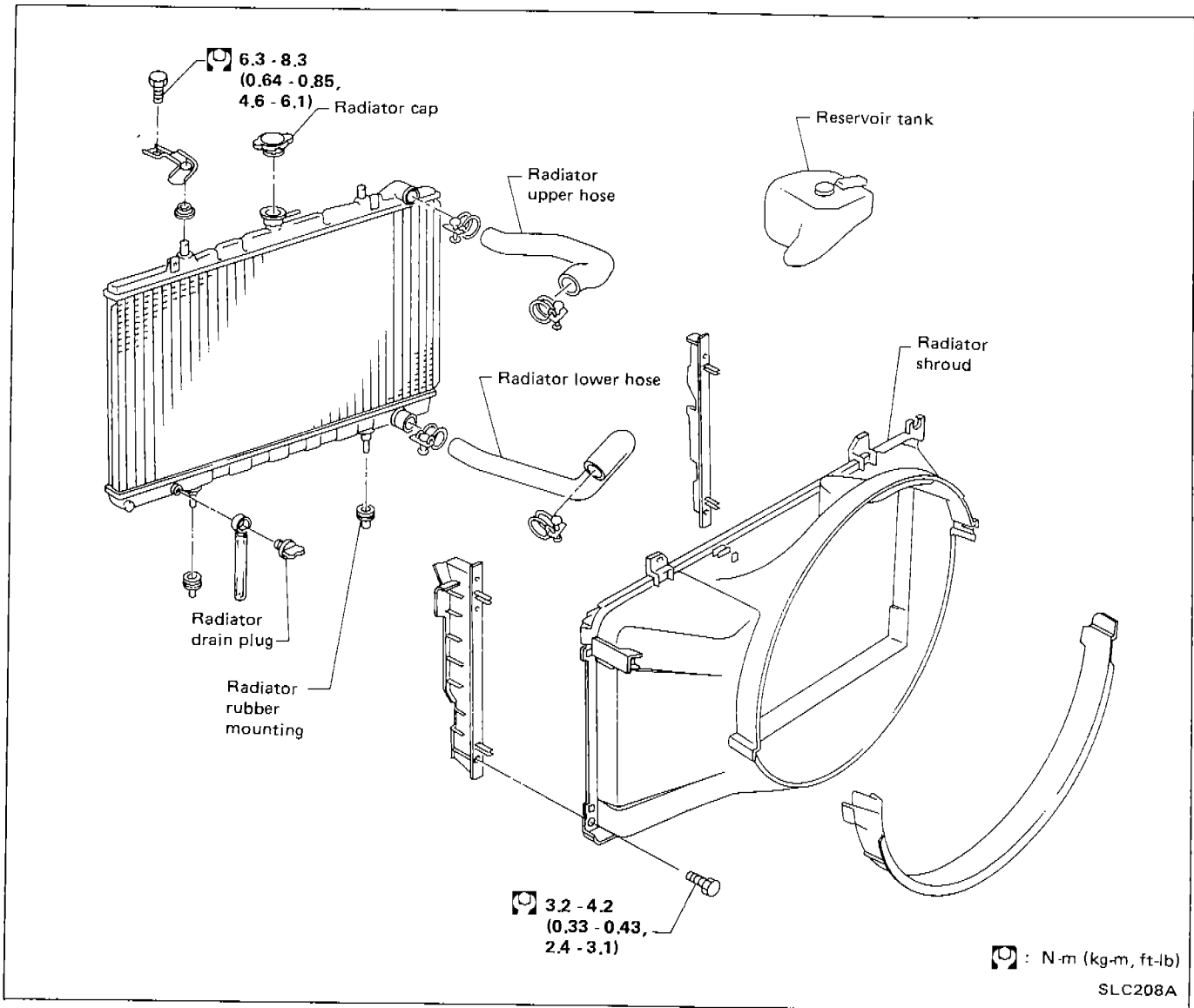

ENGINE COOLING SYSTEM

Radiator (Aluminum type)

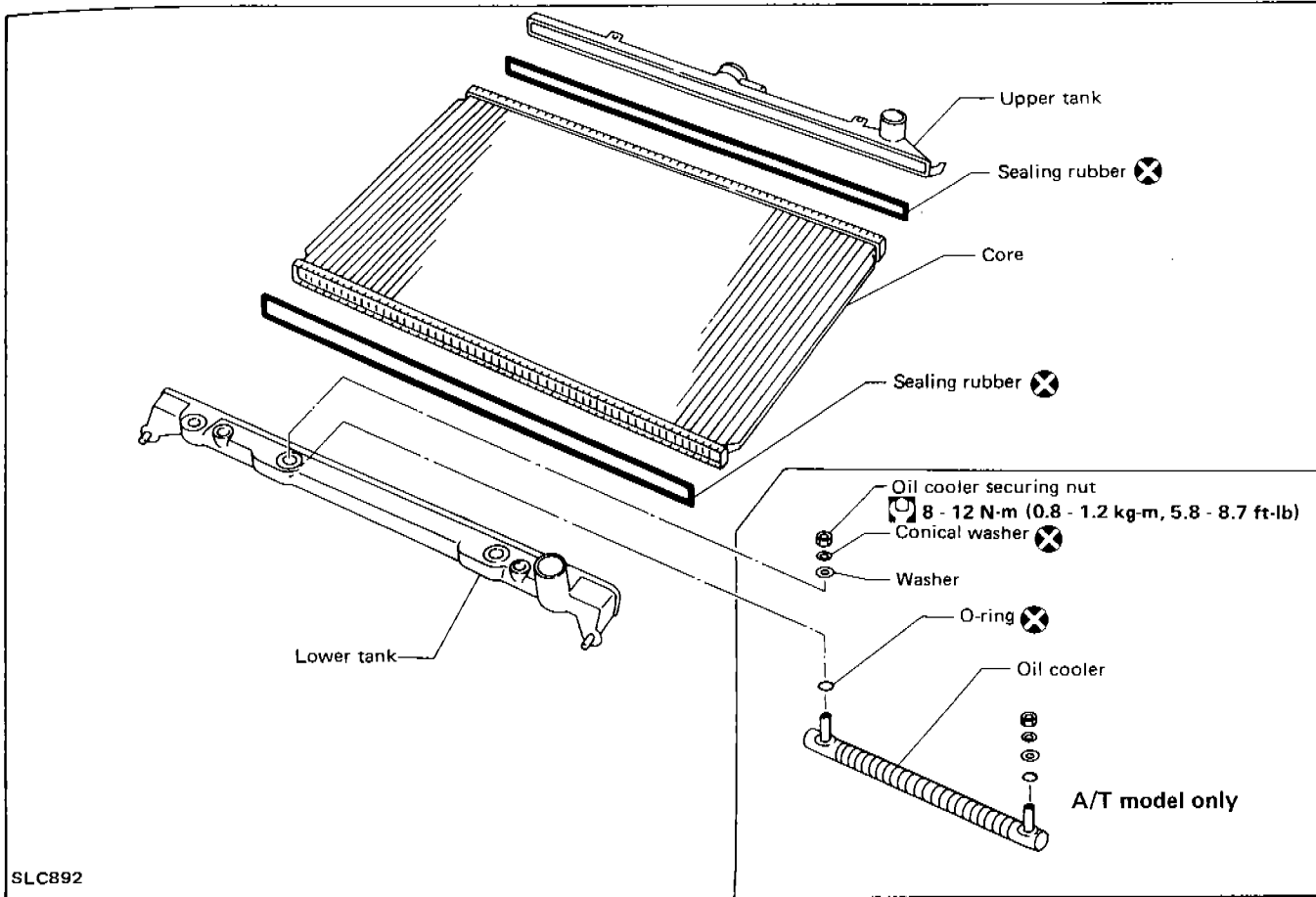

Aluminum radiator can be disassembled by using special procedures and special service tools.

DISASSEMBLY

1. Remove tank with Tool.

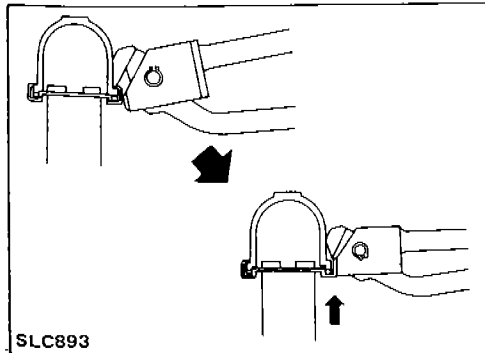
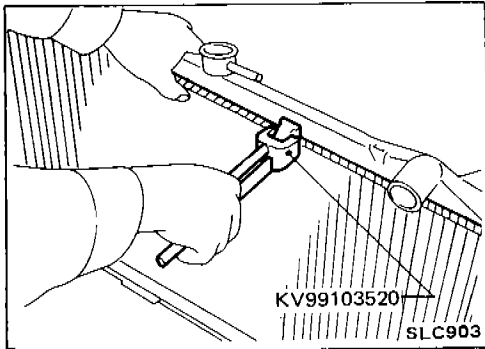

- Grip the crimped edge and bend it upwards so that Tool slips off.
Do not bend excessively.

ENGINE COOLING SYSTEM

Radiator (Aluminum type)(Cont'd)

- In areas where Tool cannot be used, use a screwdriver to bend the edge up.
Be careful not to damage tank.

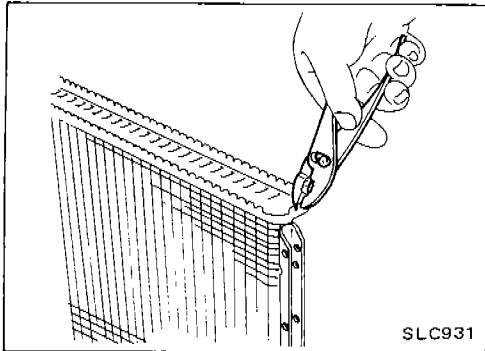
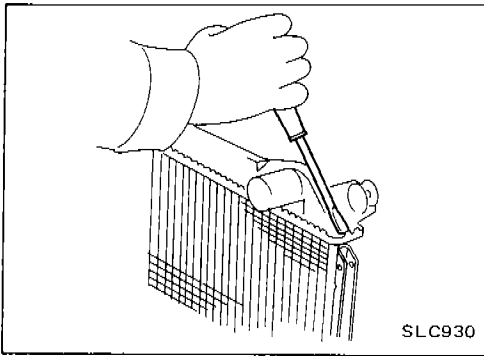

2. Make sure the edge stands straight up.
3. Remove oil cooler from tank. (A/T model only)

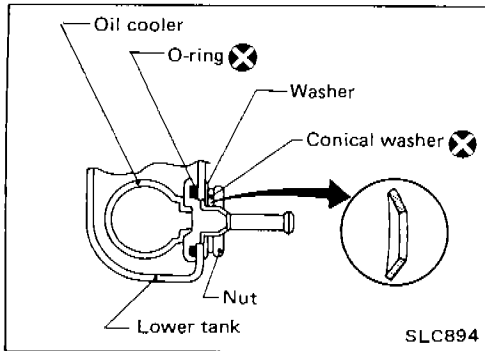

ASSEMBLY

1. Install oil cooler. (A/T model only)
Pay attention to direction of conical washer.

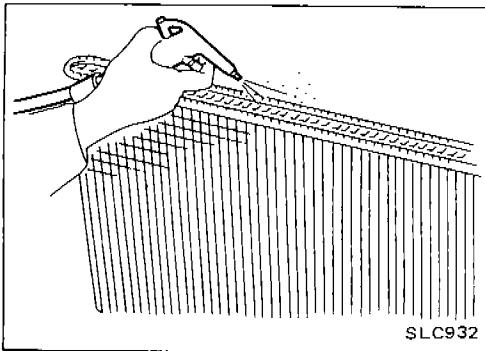

2. Clean contact portion of tank.

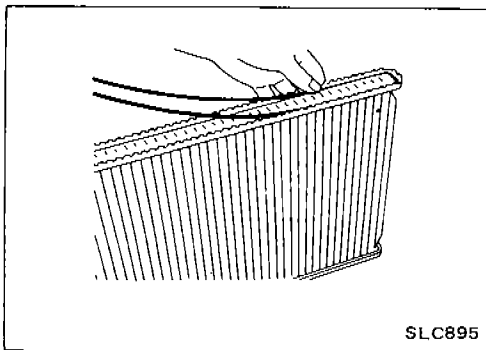

3. Install sealing rubber.
Push it in with fingers.
Be careful not to twist sealing rubber.

ENGINE COOLING SYSTEM

Radiator (Aluminum type)(Cont'd)

4. Caulk tank in specified sequence with Tool.

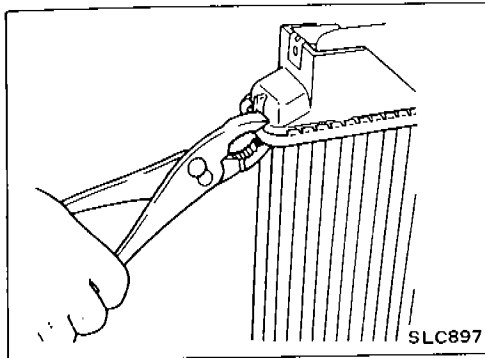
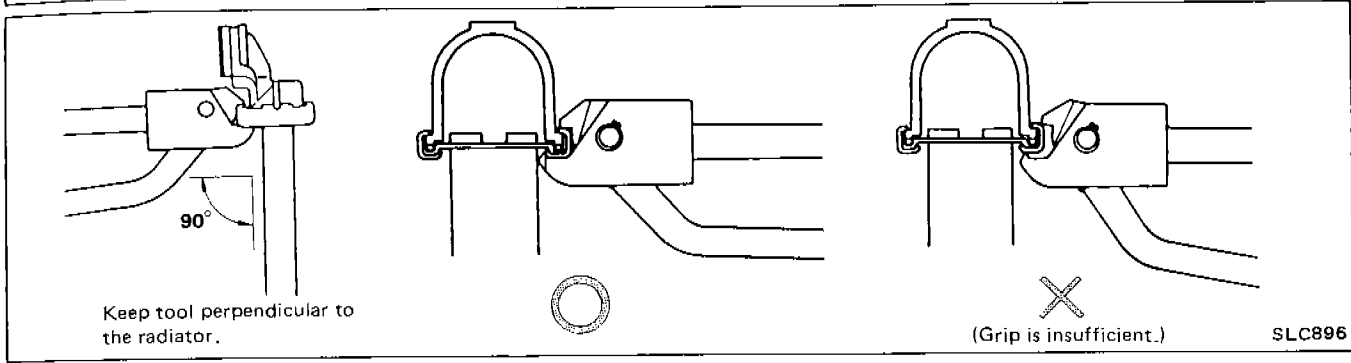
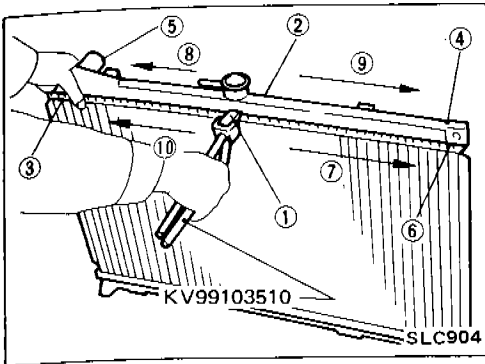

● Use pliers in the locations where Tool cannot be used.

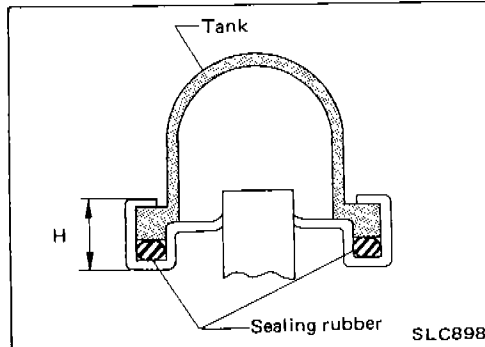

5. Make sure that the rim is completely crimped down.

Standard height "H":

11.5 mm (0.453 in)

6. Confirm that there is no leakage.

Refer to "INSPECTION".

INSPECTION

1. Apply pressure with Tool.

Specified pressure value:

157 kPa (1.57 bar, 1.6 kg/cm², 23 psi)

WARNING:

To prevent the risk of the hose coming undone while under pressure, securely fasten it down with a hose clamp.

Attach a hose to the oil cooler as well. (A/T model only)

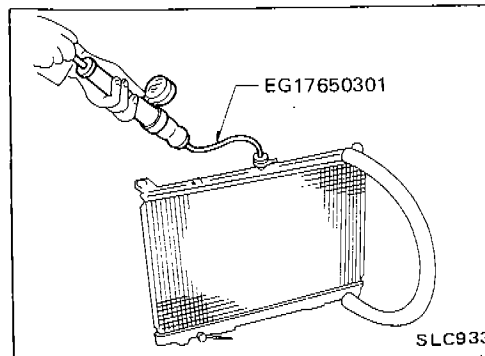

ENGINE COOLING SYSTEM

Radiator (Aluminum type)(Cont'd)

2. Check leakage.

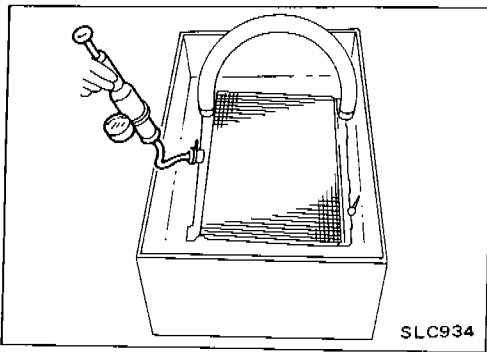

Cooling Fan

DISASSEMBLY AND ASSEMBLY

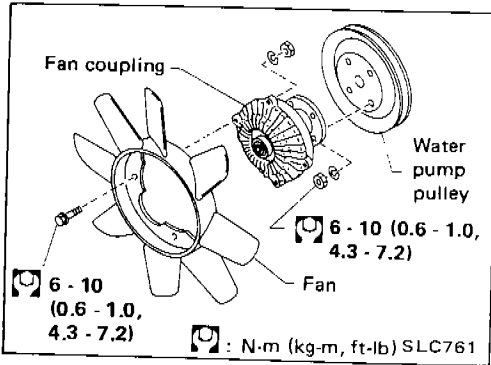

INSPECTION

Check fan coupling for rough operation, oil leakage or bent bimetal.

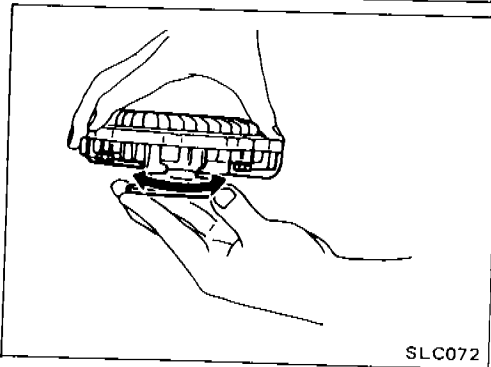

Turbocharger

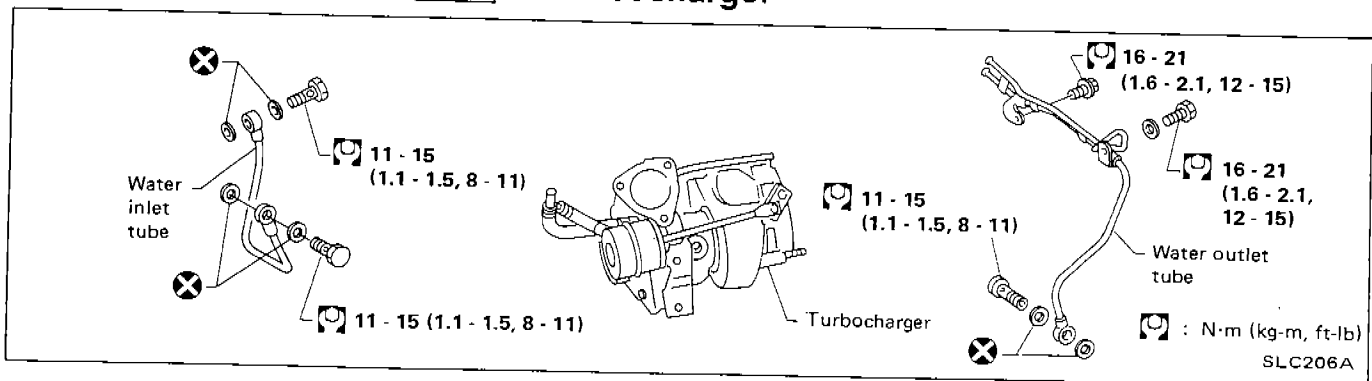

- When installing oil tubes, first hand-tighten nuts connecting tubes, then slightly tighten bracket securing bolts, and tighten nuts and bolts securely.
- Be careful not to deform tubes.
- After installation, run engine for a few minutes, and check for oil leakage.

SERVICE DATA AND SPECIFICATIONS (S.D.S.)

Engine Lubrication System

OIL PRESSURE CHECK

| Engine rpm | Approximate discharge pressure kPa (bar, kg/cm ² , psi) |
|---------------------|--------------------------------------------------------------------------------|
| Idle speed 3,000 | More than 78 (0.78, 0.8, 11) 353 - 412 (3.53 - 4.12, 3.6 - 4.2, 51 - 60) |

OIL PUMP INSPECTION

Unit: mm (in)

| | |
|----------------------------------|-------------------------------|
| Body to outer gear clearance | 0.11 - 0.20 (0.0043 - 0.0079) |
| Inner gear to crescent clearance | 0.15 - 0.26 (0.0059 - 0.0102) |
| Outer gear to crescent clearance | 0.21 - 0.32 (0.0083 - 0.0126) |
| Housing to inner gear clearance | 0.05 - 0.09 (0.0020 - 0.0035) |
| Housing to outer gear clearance | 0.05 - 0.11 (0.0020 - 0.0043) |

Engine Cooling System

THERMOSTAT

| | Standard | Cold type | Hot type* |
|-----------------------------------|--------------------|---------------------|--------------------|
| Valve opening temperature °C (°F) | 82 (180) | 88 (190) | 76.5 (170) |
| Max. valve lift mm/°C (in/°F) | 8/95 (0.31/203) | 8/100 (0.31/212) | 8/90 (0.31/194) |

RADIATOR

| | |
|-----------------------|-----------------------------------------------------|
| Leakage test pressure | 157 kPa (1.57 bar, 1.6 kg/cm ² , 23 psi) |
|-----------------------|-----------------------------------------------------|

*For general areas only



ENGINE FUEL & EMISSION CONTROL SYSTEM

SECTION **EF & EC**

EF & EC

CONTENTS

| | |
|-----------------------------------------------------------------|-------------|
| PREPARATION | EF & EC- 2 |
| PRECAUTIONS | EF & EC- 3 |
| ENGINE AND EMISSION CONTROL OVERALL SYSTEM | EF & EC- 4 |
| ENGINE AND EMISSION CONTROL DESCRIPTION | EF & EC- 9 |
| ENGINE AND EMISSION CONTROL SYSTEM DESCRIPTION | EF & EC- 14 |
| IDLE SPEED/IGNITION TIMING/IDLE MIXTURE RATIO INSPECTION | EF & EC- 25 |
| TROUBLE DIAGNOSES | EF & EC- 32 |
| FUEL INJECTION CONTROL SYSTEM INSPECTION | EF & EC-129 |
| EVAPORATIVE EMISSION CONTROL SYSTEM (For catalyzer model) | EF & EC-132 |
| CRANKCASE EMISSION CONTROL SYSTEM | EF & EC-134 |
| SERVICE DATA AND SPECIFICATIONS (S.D.S.) | EF & EC-136 |

When you read wiring diagrams:

- Read GI section, "HOW TO READ WIRING DIAGRAMS".
- See EL section, "POWER SUPPLY ROUTING" for power distribution circuit.

When you perform trouble diagnoses, read GI section, "HOW TO FOLLOW FLOW CHART IN TROUBLE DIAGNOSES".

E.C.C.S Wiring Diagram — See pull-out following EL section.

ENGINE AND EMISSION CONTROL OVERALL SYSTEM

E.C.C.S. Component Parts Location

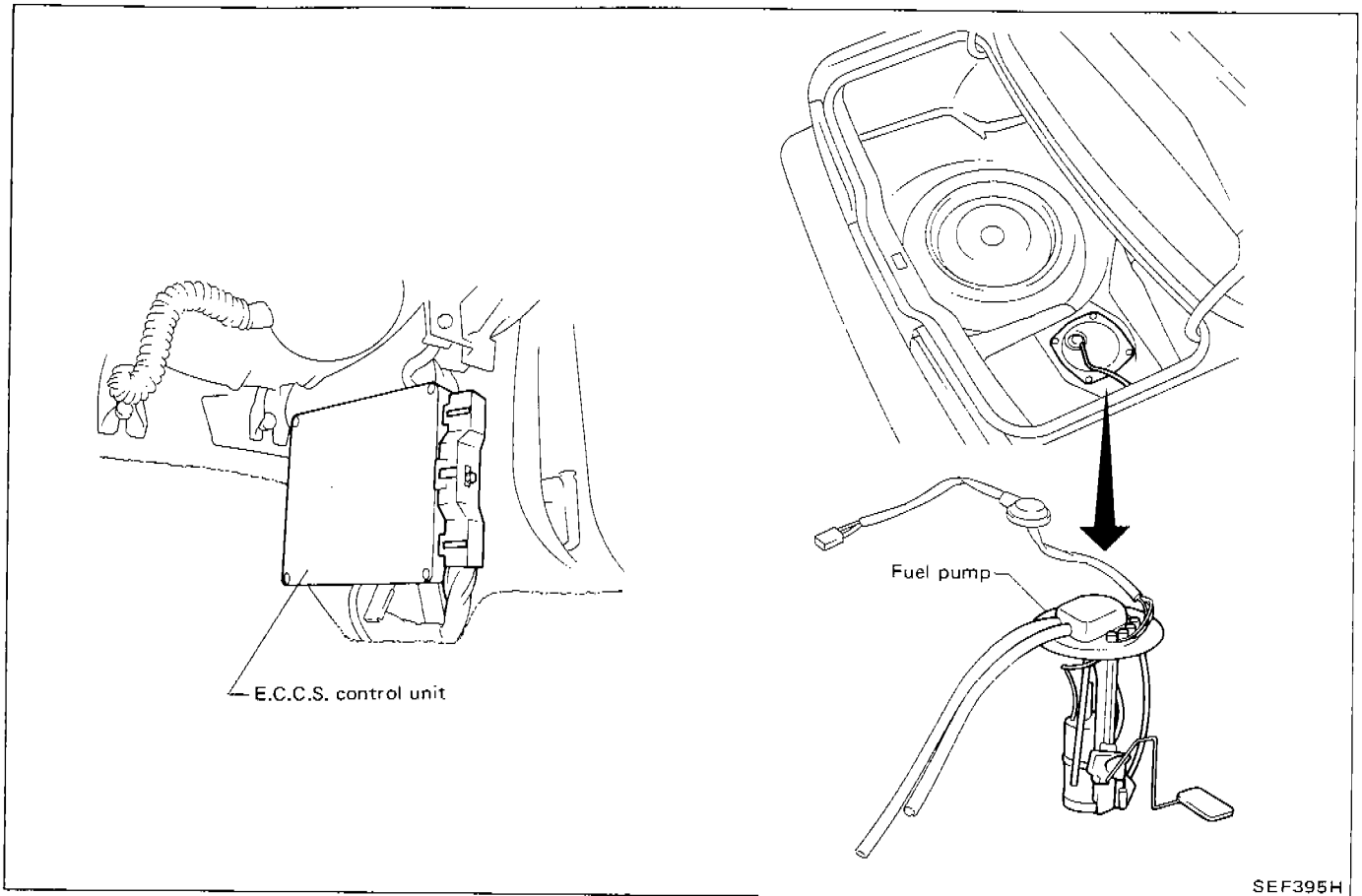

ENGINE AND EMISSION CONTROL OVERALL SYSTEM

E.C.C.S. Component Parts Location (Cont'd)

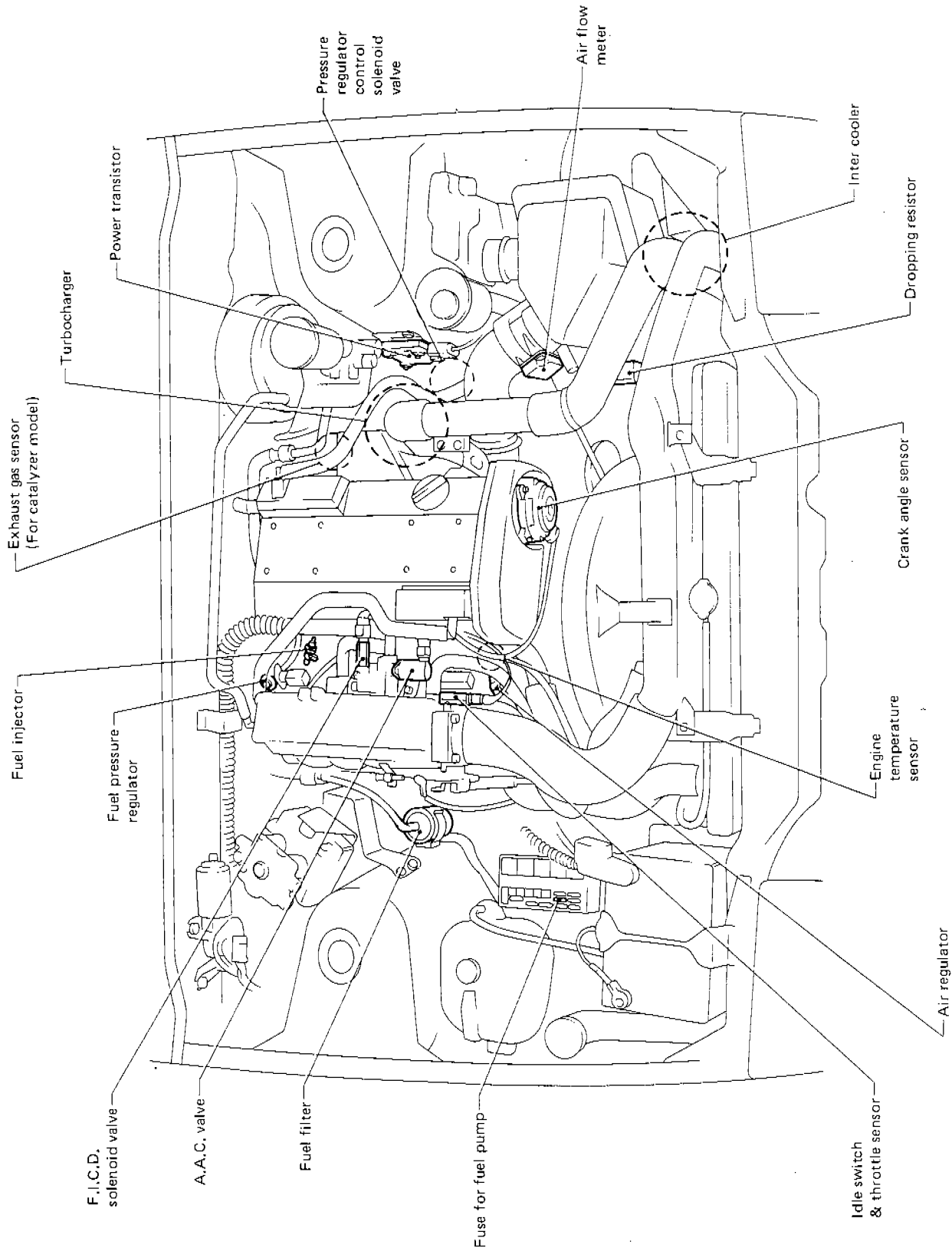

SEF396H

ENGINE AND EMISSION CONTROL OVERALL SYSTEM

System Diagram

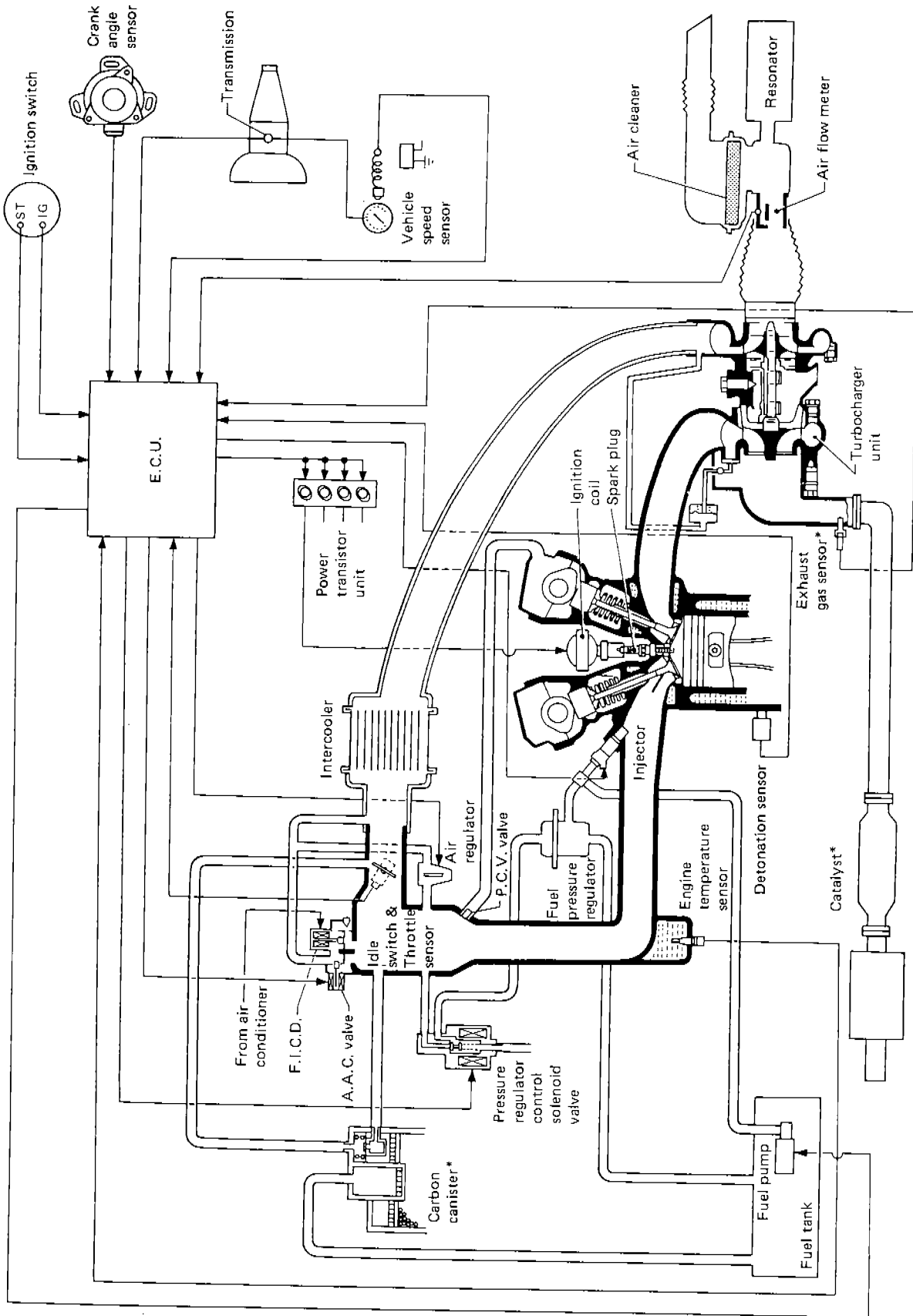

*Model with catalyzer

ENGINE AND EMISSION CONTROL OVERALL SYSTEM

System Chart

E.C.C.S. CONTROL

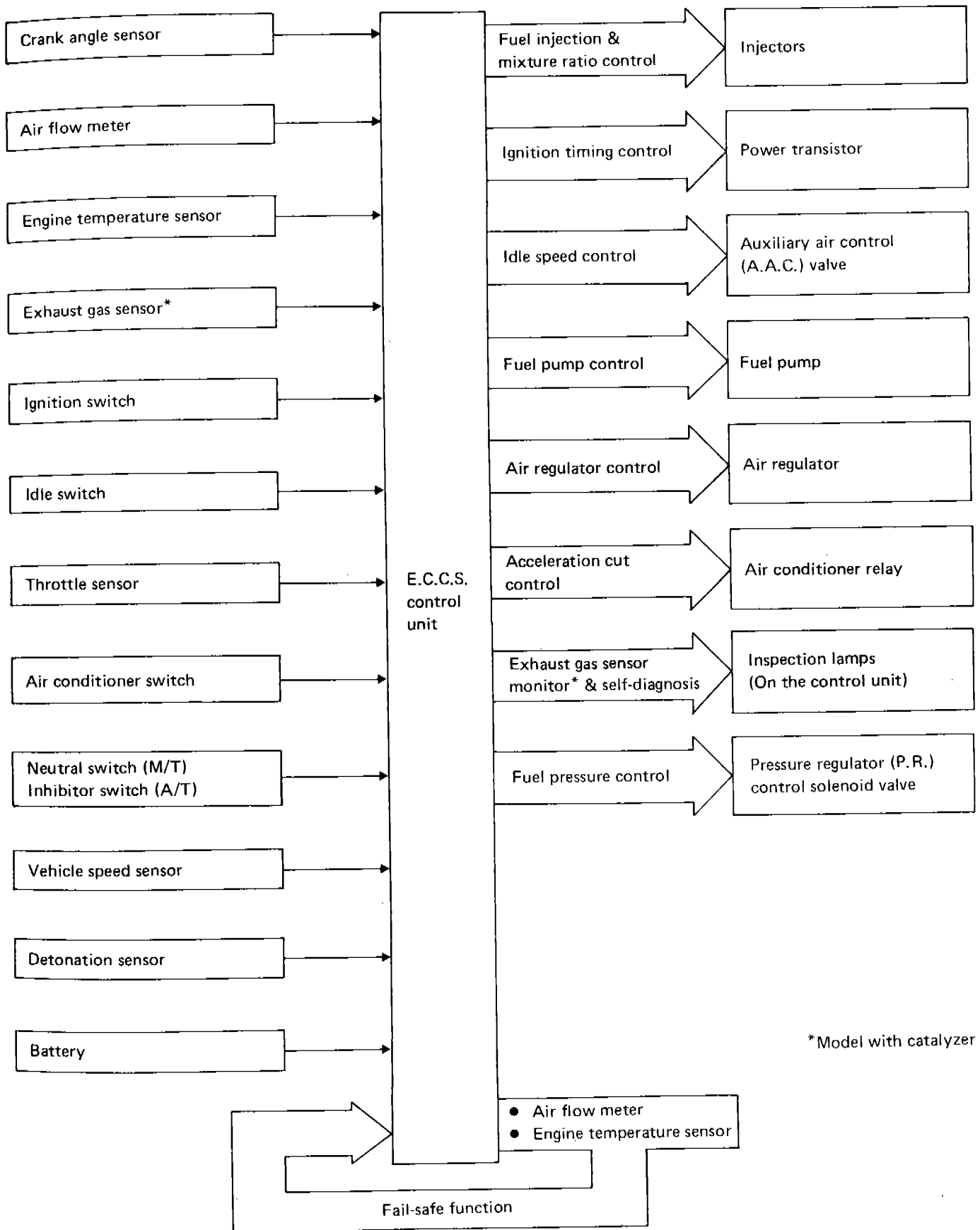

ENGINE AND EMISSION CONTROL PARTS DESCRIPTION

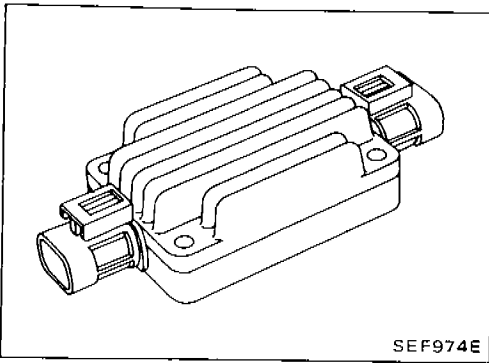

Power Transistor

The ignition signal from the E.C.U. is amplified by the power transistor, which turns the ignition coil primary circuit on and off, inducing the proper high voltage in the secondary circuit.

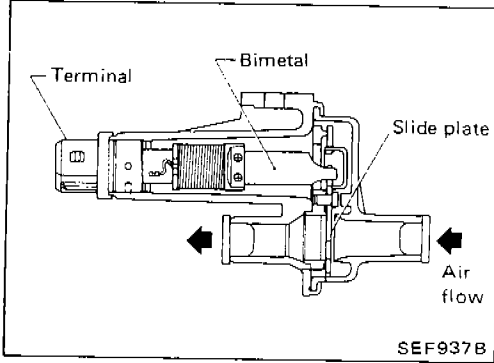

Air Regulator

The air regulator provides an air by-pass when the engine is cold for a fast idle during warm-up.

A bimetal, heater and rotary shutter are built into the air regulator. When the bimetal temperature is low, the air by-pass port opens. As the engine starts and electric current flows through a heater, the bimetal begins to turn the shutter to close the by-pass port. The air passage remains closed until the engine stops and the bimetal temperature drops.

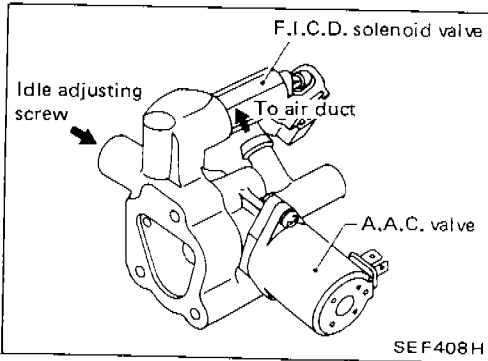

Idle Air Adjusting (I.A.A.) Unit

The I.A.A. unit is made up of the A.A.C. valve, F.I.C.D. solenoid valve and idle adjust screw. It receives the signal from the E.C.U. and controls the idle speed at the preset value.

The F.I.C.D. solenoid valve compensates for changes in idle speed caused by the operation of the air compressor.

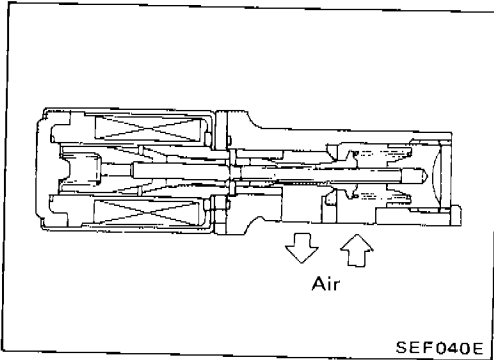

Auxiliary Air Control (A.A.C.) Valve

The E.C.U. actuates the A.A.C. valve by an ON/OFF pulse. The longer that ON duty is left on, the larger the amount of air that will flow through the A.A.C. valve.

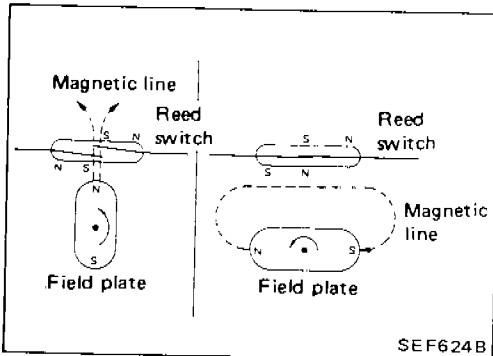

Vehicle Speed Sensor

The vehicle speed sensor provides a vehicle speed signal to the E.C.U.

The speed sensor consists of a reed switch and a speedometer pinion, which are installed in the transmission, and transforms vehicle speed into pulse signals.

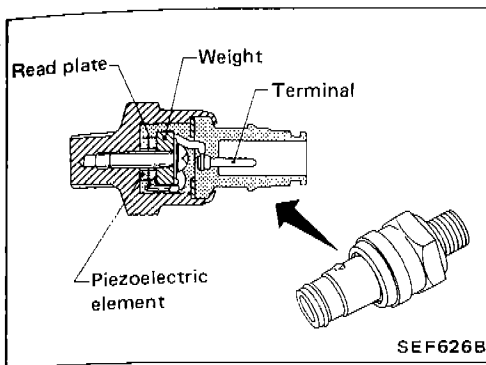

Detonation Sensor

The detonation sensor is attached to the cylinder block and senses engine knocking conditions.

A knocking vibration from the cylinder block is applied as pressure to the piezoelectric element. This vibrational pressure is then converted into a voltage signal which is delivered as output.

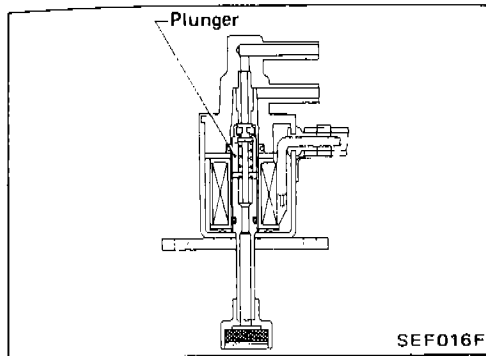

Pressure Regulator (P.R.) Control Solenoid Valve

The solenoid valve responds to the ON/OFF signal from the E.C.U. When it is off, a vacuum signal from the intake manifold is fed into the pressure regulator. When the control unit sends an ON signal, the coil pulls the plunger downward and cuts the vacuum signal.

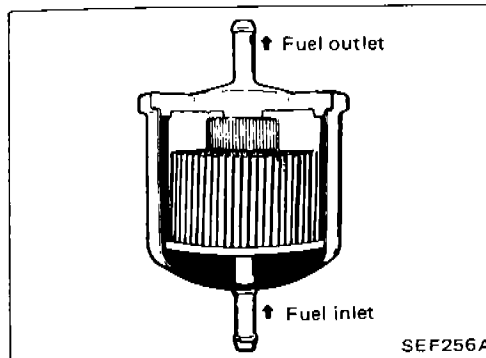

Fuel Filter

The specially designed fuel filter has a metal case in order to withstand high fuel pressure.

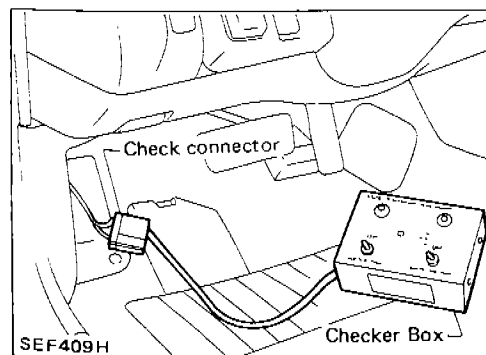

Check Connector for E.C.C.S. Checker Box

The check connector for E.C.C.S. Checker Box is in the vicinity of the fuse box.

ENGINE AND EMISSION CONTROL SYSTEM DESCRIPTION

Fuel Injection Control INPUT/OUTPUT SIGNAL LINE

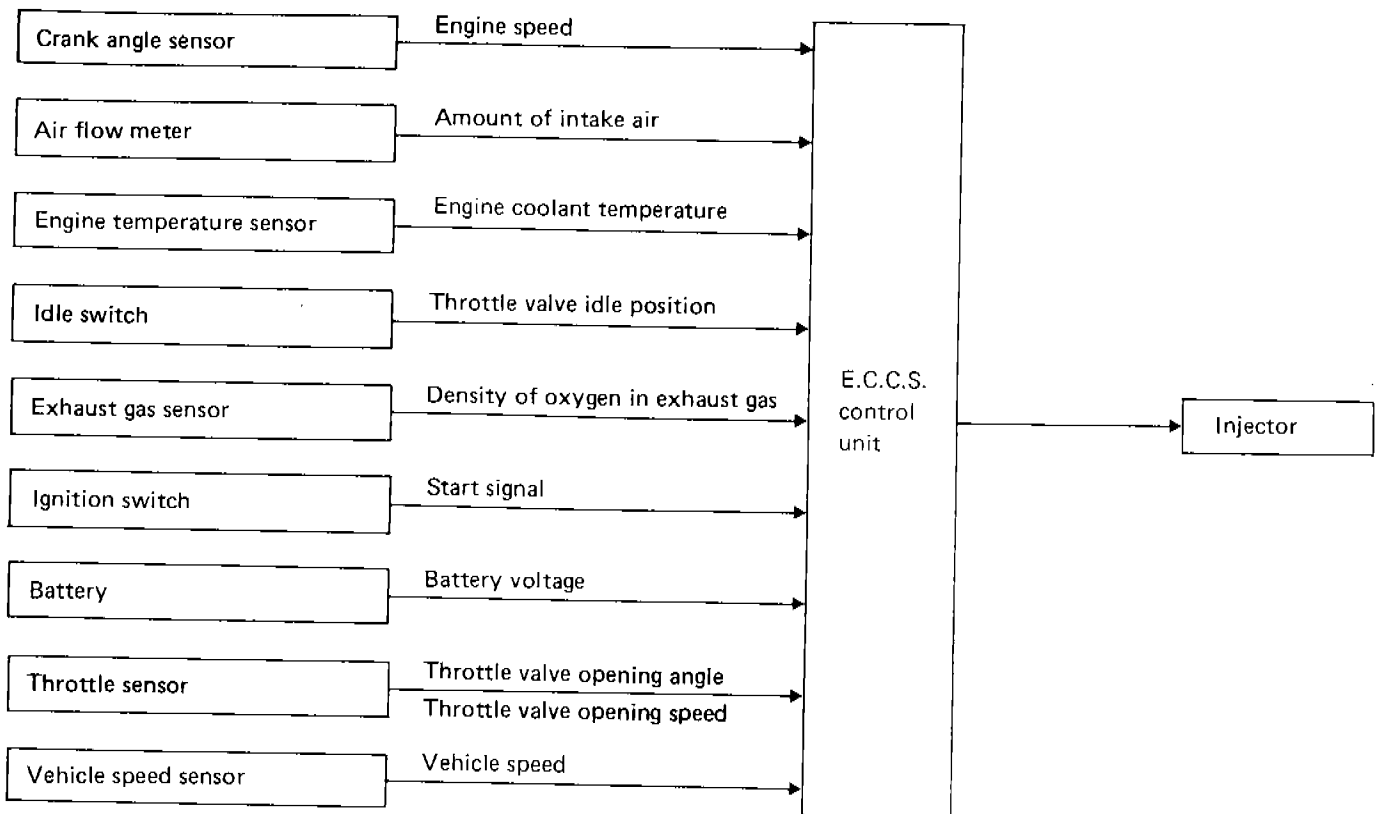

BASIC FUEL INJECTION CONTROL

The amount of fuel injected from the fuel injector, or the length of time the valve remains open, is determined by the E.C.U. The basic amount of fuel injected is a program value mapped in the E.C.U. ROM memory. In other words, the program value is preset by engine operating conditions determined by input signals (for engine rpm and air intake) from both the crank angle sensor and the air flow meter.

VARIOUS FUEL INJECTION INCREASE/DECREASE COMPENSATION

In addition, the amount of fuel injection is compensated for to improve engine performance under various operating conditions as listed below:

<Fuel increase>

- 1) During warm-up
- 2) When starting the engine
- 3) During acceleration
- 4) Hot-engine operation

<Fuel decrease>

- 1) During deceleration

Fuel Injection Control (Cont'd)

MIXTURE RATIO FEEDBACK CONTROL (For catalyzer model)

Mixture ratio feedback system is designed to precisely control the mixture ratio to the stoichiometric point so that the three-way catalyst can reduce CO, HC and NOx emissions. This system uses an exhaust gas sensor in the exhaust manifold to check the air-fuel ratio. The control unit adjusts the injection pulse width according to the sensor voltage so the mixture ratio will be within the range of the stoichiometric air-fuel ratio.

This stage refers to the closed-loop control condition. The open-loop control condition refers to that under which the E.C.U. detects any of the following conditions and feedback control stops in order to maintain stabilized fuel combustion.

- 1) Deceleration
- 2) High-load, high-speed operation
- 3) Engine idling
- 4) Malfunctioning of exhaust gas sensor or its circuit
- 5) Insufficient activation of exhaust gas sensor at low engine temperature
- 6) Engine starting

MIXTURE RATIO SELF-LEARNING CONTROL (For catalyzer model)

The air-fuel ratio feedback control system monitors the air-fuel signal transmitted from the exhaust gas sensor. This feedback signal is then sent to the E.C.U. to control the amount of fuel injection to provide a basic air-fuel ratio as close to the theoretical air-fuel ratio as possible. However, the basic air-fuel ratio is not necessarily controlled as originally designed. This is due to manufacturing errors (e.g., air flow meter hot wire) and changes during operation (injector clogging, etc.) of E.C.C.S. parts which directly affect the air-fuel ratio.

Accordingly, a difference between the basic and theoretical air-fuel ratios is quantitatively monitored in this system. It is then computed in terms of "fuel injection duration" to automatically compensate for the difference between the two ratios.

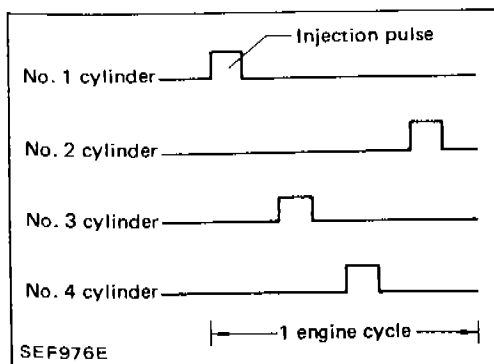
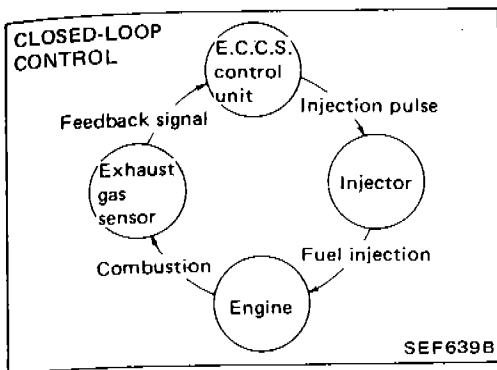

FUEL INJECTION TIMING

Fuel is injected once a cycle for each cylinder in the firing order.

ENGINE AND EMISSION CONTROL SYSTEM DESCRIPTION

Fuel Injection Control (Cont'd)

When engine temperature is low, engine starts, or engine load is heavy, fuel is injected into all four cylinders simultaneously twice a cycle.

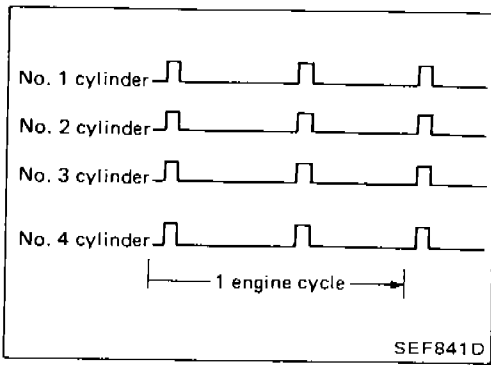

FUEL SHUT-OFF

Fuel to all cylinders is cut off during deceleration or high-speed operation.

Ignition Timing Control INPUT/OUTPUT SIGNAL LINE

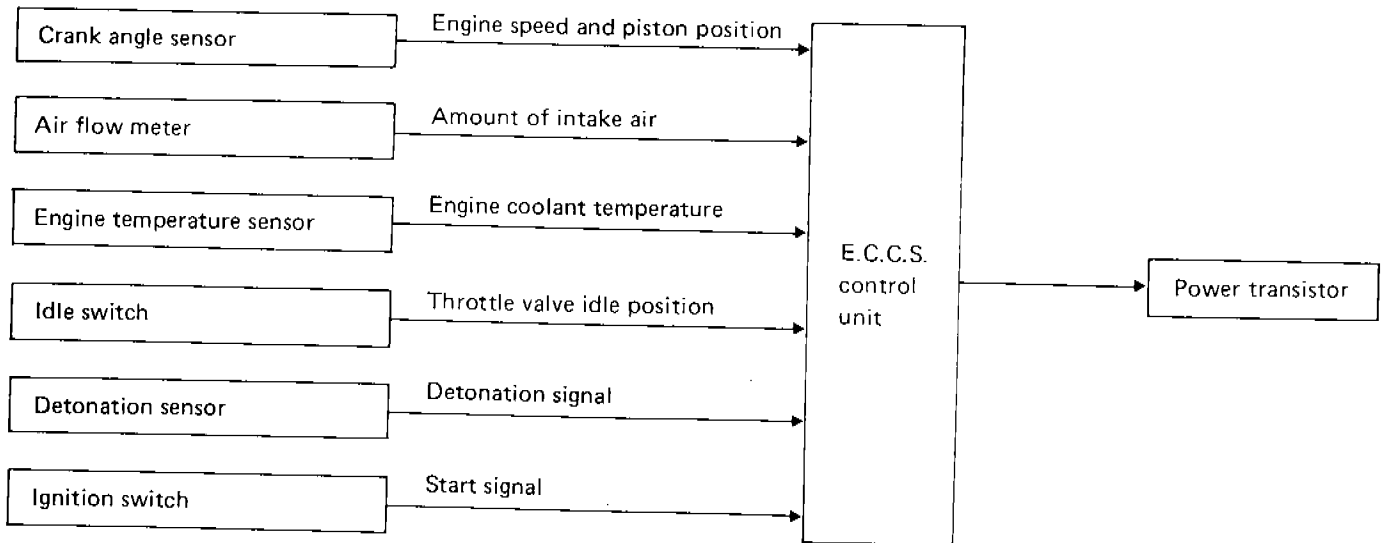

ENGINE AND EMISSION CONTROL SYSTEM DESCRIPTION

Ignition Timing Control (Cont'd)

SYSTEM DESCRIPTION

The ignition timing is controlled by the E.C.U. in order to maintain the best air-fuel ratio in response to every running condition of the engine. The ignition timing data is stored in the ROM located in the E.C.U., in the form of the map shown below.

The E.C.U. detects information such as the injection pulse width and crank angle sensor signal which varies every moment. Then responding to this information, ignition signals are transmitted to the power transistor.

e.g. N: 1,800 rpm, Tp: 1.50 msec.

A °B.T.D.C.

In addition to this,

1 At starting

2 During warm-up

3 At idle

4 At low battery voltage

the ignition timing is revised by the E.C.U. according to the other data stored in the ROM.

The retard system by detonation sensor is designed only for emergencies. The basic ignition timing is pre-programmed within the anti-knocking zone, even if recommended fuel is used under dry conditions. Consequently, the retard system does not operate under normal driving conditions.

However, if engine knocking occurs, the detonation sensor monitors the condition and the signal is transmitted to the E.C.C.S. control unit. After receiving it, the control unit retards the ignition timing to avoid the knocking condition.

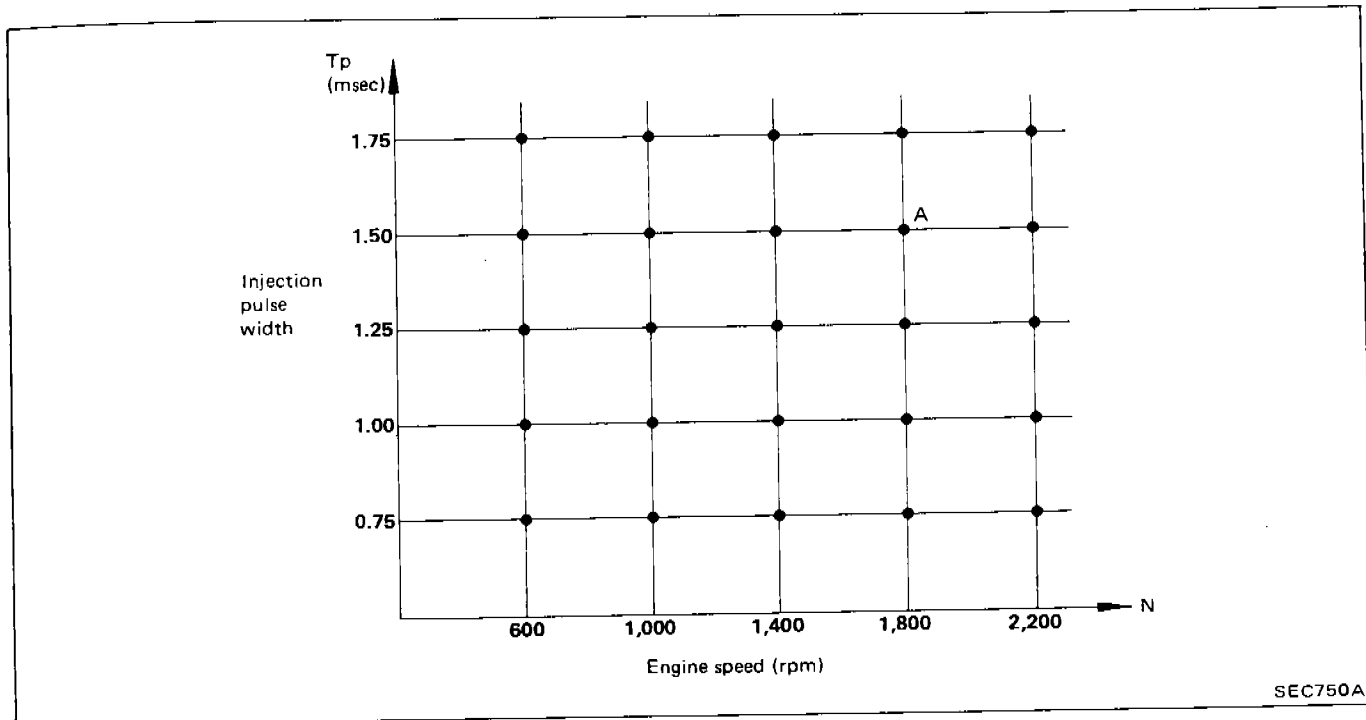

ENGINE AND EMISSION CONTROL SYSTEM DESCRIPTION

Idle Speed Control

INPUT/OUTPUT SIGNAL LINE

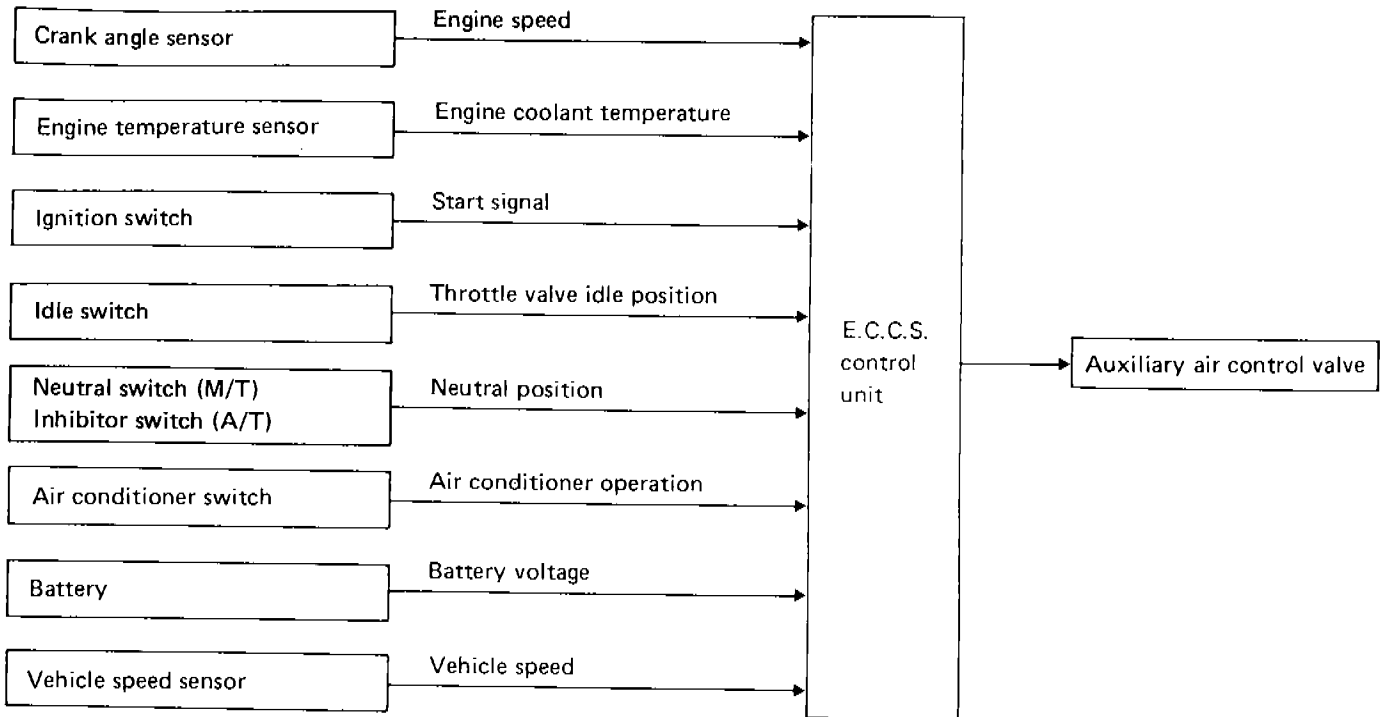

SYSTEM DESCRIPTION

This system automatically controls engine idle speed to a specified level. Idle speed is controlled through fine adjustment of the amount of air which by-passes the throttle valve via A.A.C. valve. The A.A.C. valve repeats ON/OFF operation according to the signal sent from the E.C.U. The crank angle sensor detects the actual engine speed and sends a signal to the E.C.U. The E.C.U.

then controls the ON/OFF time of the A.A.C. valve so that engine speed coincides with the target value memorized in ROM. The target engine speed is the lowest speed at which the engine can operate steadily. The optimum value stored in the ROM is determined by taking into consideration various engine conditions, such as noise and vibration transmitted to the compartment, fuel consumption, and engine load.

ENGINE AND EMISSION CONTROL SYSTEM DESCRIPTION

Fuel Pump Control INPUT/OUTPUT SIGNAL LINE

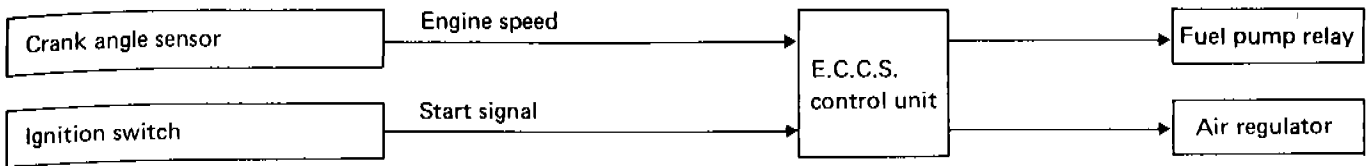

SYSTEM DESCRIPTION

The E.C.U. activates the fuel pump for several seconds after the ignition switch is turned on to improve engine startability. If the E.C.U. receives a 1° signal from the crank angle sensor, it knows that the engine is rotating, and causes the pump to rotate. If the 1° signal is not received when the ignition switch is on, the engine stalls. The E.C.U. stops pump operation and prevents battery discharging, thereby improving safety. The E.C.U. does not directly drive the fuel pump. It controls ON/OFF of the fuel pump relay, which in turn controls the fuel pump.

Fuel pump and air regulator ON-OFF control

| Ignition switch position | Engine condition | Fuel pump/ Air regulator operation |
|--------------------------|------------------|---------------------------------------|
| ON | Stopped | Operates for 5 seconds |
| | Running | Operates |
| | After stopped | Stops after 1 second |
| START | Starting | Operates |

Air Regulator Control

SYSTEM DESCRIPTION

The air regulator is controlled by the E.C.U. at the same time as fuel pump ON-OFF control.

Fuel Pressure Regulator Control INPUT/OUTPUT SIGNAL LINE

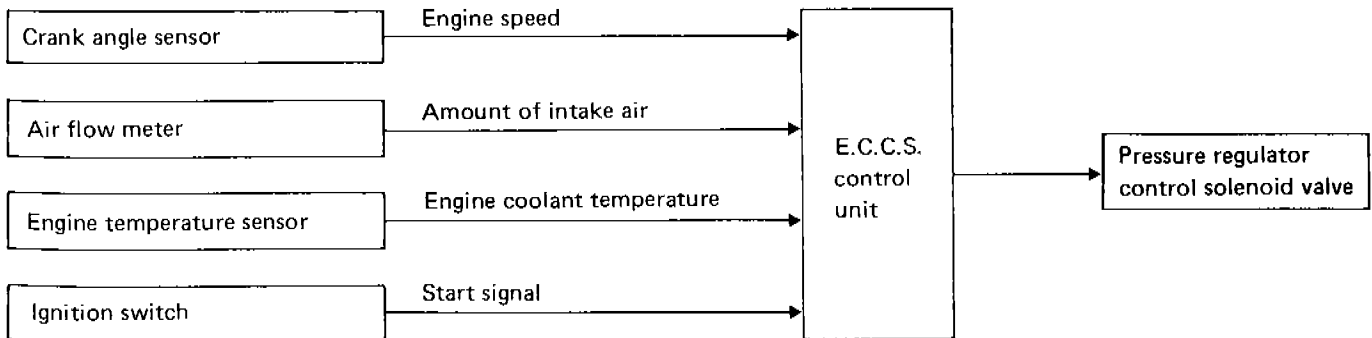

ENGINE AND EMISSION CONTROL SYSTEM DESCRIPTION

Fuel Pressure Regulator Control (Cont'd)

SYSTEM DESCRIPTION

The fuel "pressure-up" control system briefly increases fuel pressure for improved starting performance of a hot engine. Under normal operating conditions, manifold vacuum is applied to the fuel pressure regulator. When starting the engine,

however, the E.C.U. allows current to flow through the ON/OFF solenoid valve in the control vacuum line, opening this line to the atmosphere. As a result, atmospheric pressure is applied, throttling the fuel passage to increase fuel pressure.

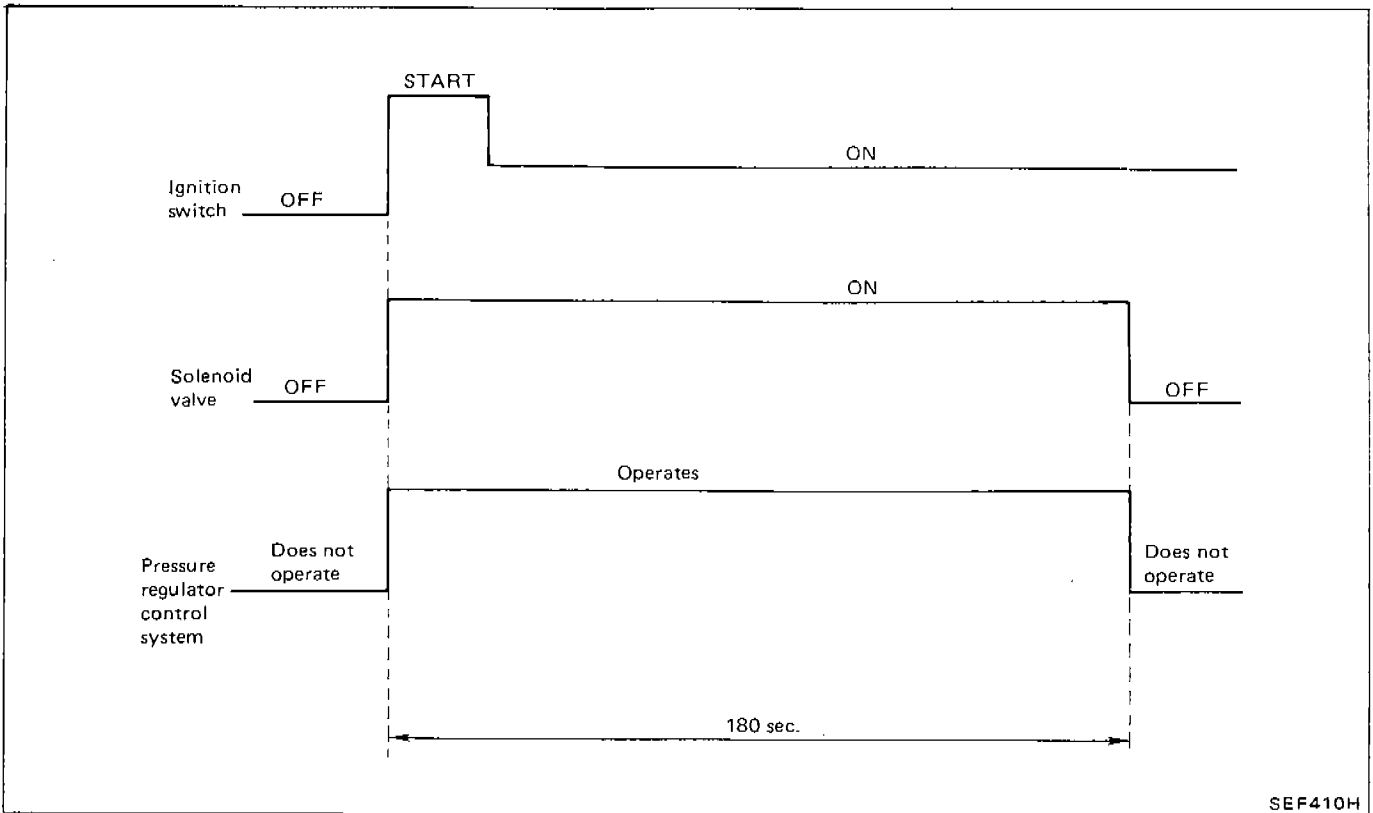

Acceleration Cut Control INPUT/OUTPUT SIGNAL LINE

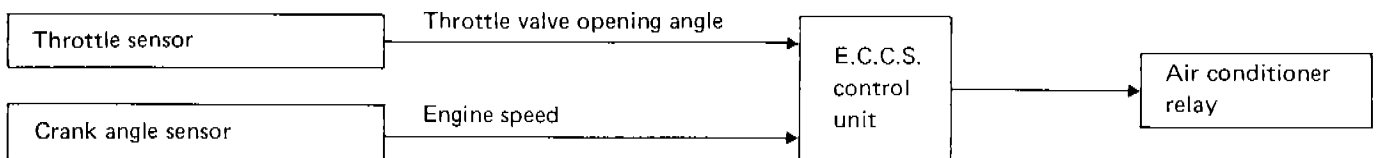

SYSTEM DESCRIPTION

When E.C.U. detects heavy load conditions, air conditioner is turned off for a few seconds. This system improves acceleration when air conditioner is used.

ENGINE AND EMISSION CONTROL SYSTEM DESCRIPTION

Exhaust Gas Sensor Heater Control (For catalyzer model)

INPUT/OUTPUT SIGNAL LINE

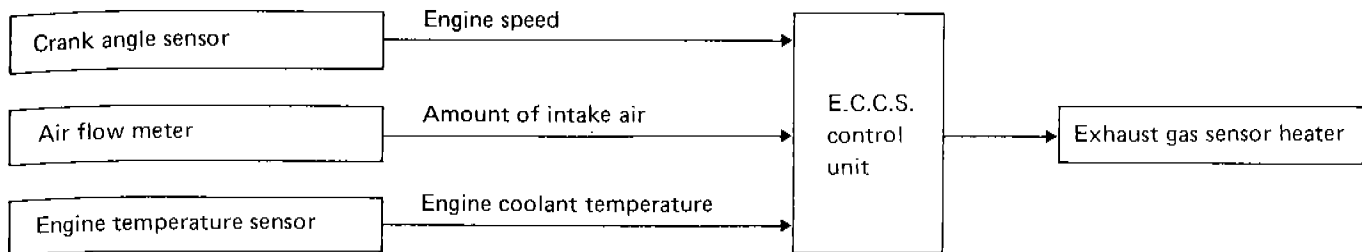

SYSTEM DESCRIPTION

The exhaust gas sensor heater helps activate the sensor quickly to stabilize closed-loop control under all operating conditions.

Fail-safe System

AIR FLOW METER MALFUNCTION

If the air flow meter output voltage is above or below the specified value, the E.C.U. senses an air flow meter malfunction. In case of a malfunction, the throttle sensor substitutes for the air flow meter.

Though air flow meter is malfunctioning, it is possible to drive the vehicle and start the engine. But engine speed will not rise more than 2,000 rpm in order to inform the driver of fail-safe system operation while driving.

ENGINE TEMPERATURE SENSOR MALFUNCTION

When engine temperature sensor output voltage is below or above the specified value, engine temperature is fixed at the preset value as follows:

| Engine condition | Engine temperature preset value °C (°F) |
|------------------|--------------------------------------------|
| Start | 20 (68) |
| Running | 80 (176) |

Direct Ignition System

This system has no conventional distributor and high-tension wires. Small, very efficient ignition

coils are fitted directly to each spark plug.

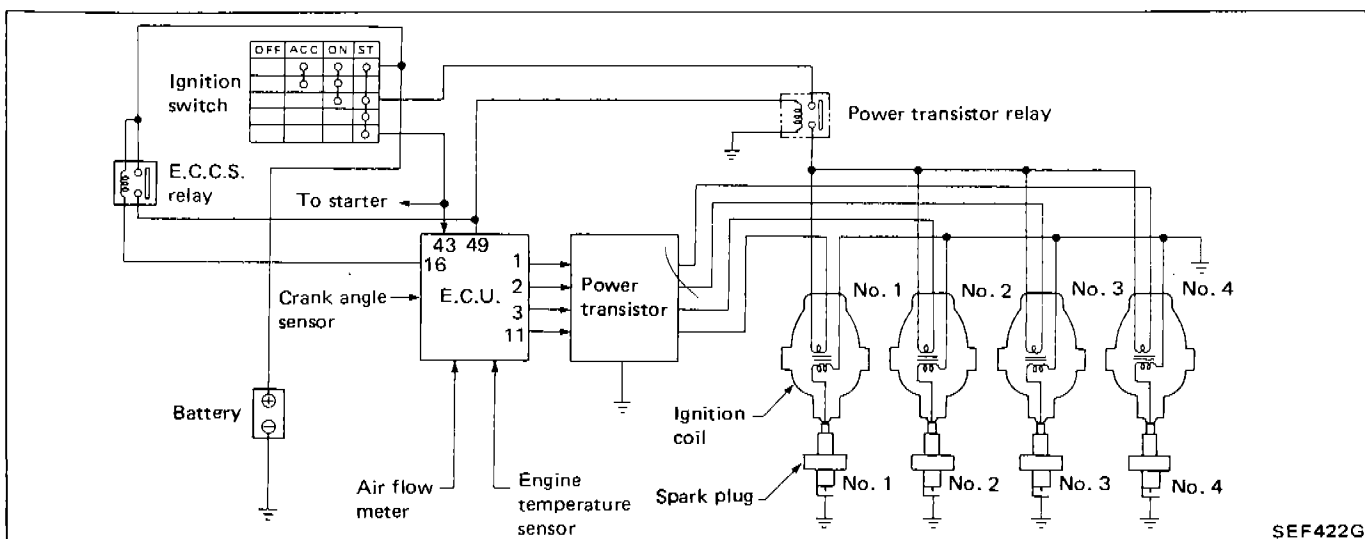

ENGINE AND EMISSION CONTROL SYSTEM DESCRIPTION

Direct Ignition System (Cont'd)

CHECKING IGNITION TIMING AND IDLE SPEED

Checking idle speed

Idle speed:

M/T: 850 ± 50 rpm

A/T: 850 ± 50 rpm (in "N" position)

If idle speed is not within specific value, refer to **IDLE SPEED/IGNITION TIMING/IDLE MIXTURE RATIO INSPECTION.**

- METHOD A (With pulse type tachometer)

Clamp loop wire as shown.

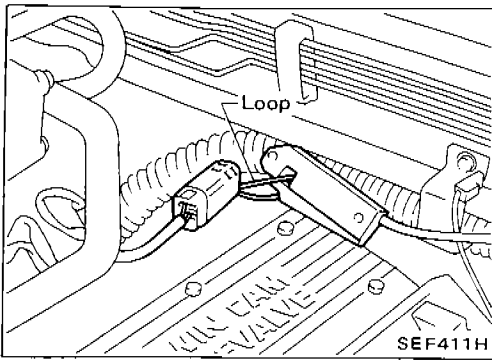

L.H. model

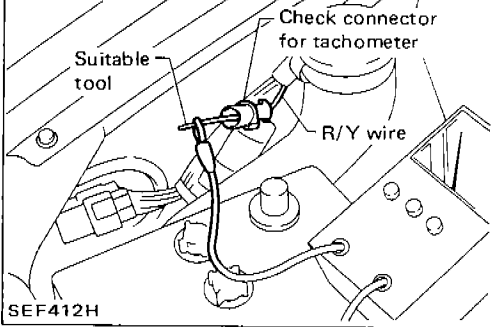

R.H. model

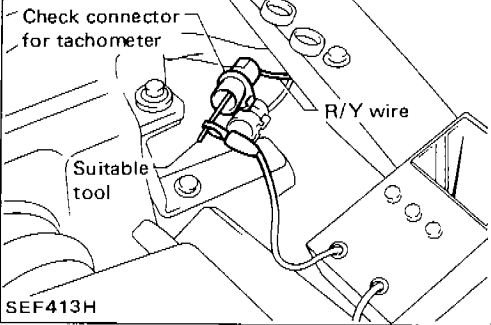

- METHOD B (With voltage type tachometer)
1. Disconnect check connector for tachometer.

2. Connect tachometer using suitable tool.

Checking ignition timing

Ignition timing: $15^\circ \pm 2^\circ$ B.T.D.C.

If ignition timing is not within specific value, adjust ignition timing as shown.

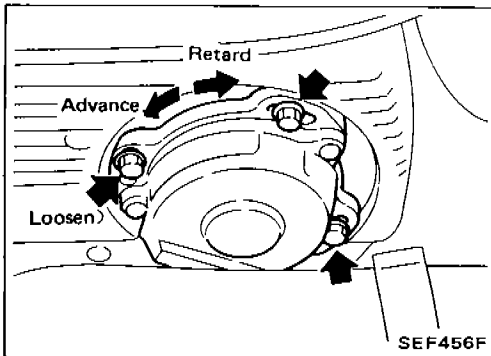

- METHOD A (Without Tool)

1. Remove ornament cover.

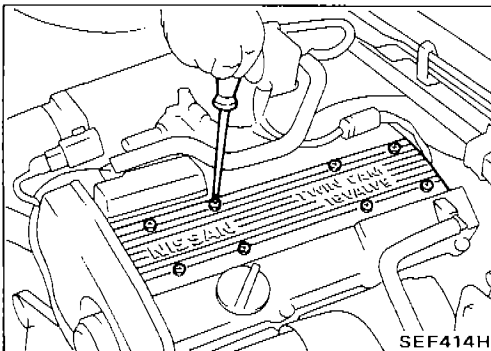

ENGINE AND EMISSION CONTROL SYSTEM DESCRIPTION

Direct Ignition System (Cont'd)

2. Remove No. 1 ignition coil.

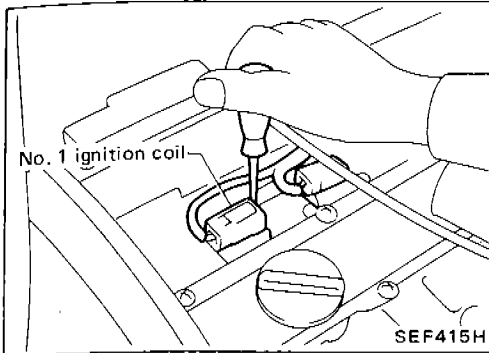

3. Connect No. 1 ignition coil and No. 1 spark plug with suitable high-tension wire as shown, and clamp this wire with timing light clamp.

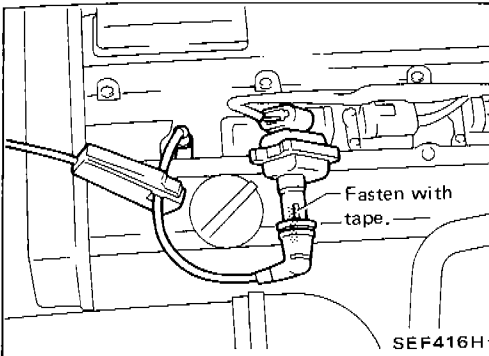

4. Check ignition timing.

5. Install No. 1 ignition coil and ornament cover.

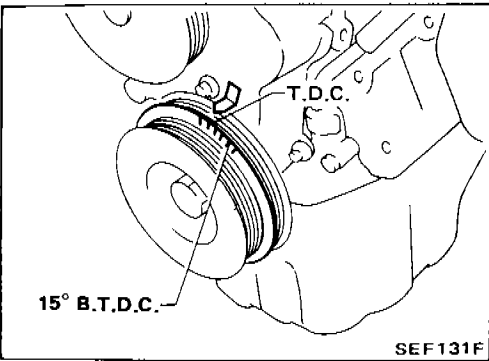

For above procedures, enlarge suitable high-tension wire end with insulating tape as shown.

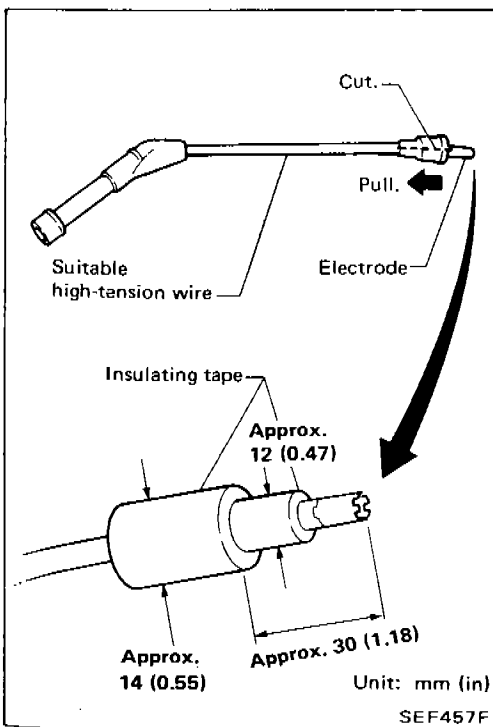

ENGINE AND EMISSION CONTROL SYSTEM DESCRIPTION

Direct Ignition System (Cont'd)

- METHOD B (With Tool KV109D10S0)

1. Disconnect connector of power transistor unit.

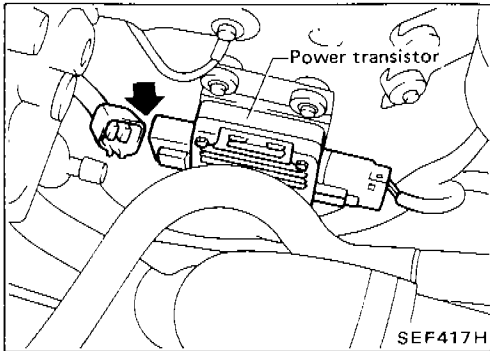

2. Connect Tool and clamp wire as shown.

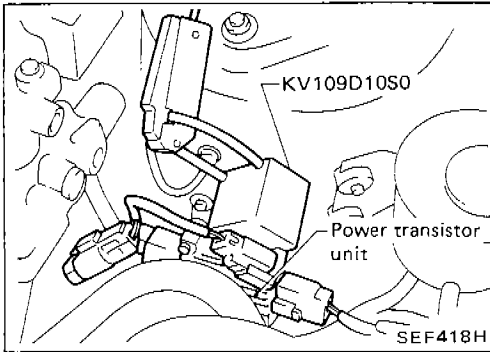

Align direction marks on Tool and timing light clamp if aligning mark is punched.

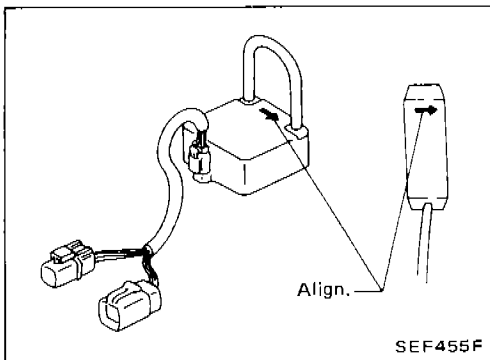

IDLE SPEED/IGNITION TIMING/IDLE MIXTURE RATIO INSPECTION

Preparation

Make sure that the following parts are in good condition.

- **Battery**
- **Ignition system**
- **Engine oil and coolant levels**
- **Fuses**
- **E.C.C.S. harness connectors**
- **Vacuum hoses**
- **Air intake system**
(oil filler cap, oil level gauge, etc.)
- **Fuel pressure**
- **Engine compression**
- **Throttle valve**
- **Fuel pressure regulator control system**

Notice

1. Turn off air conditioner and headlamps.
2. During checking and adjusting, make sure engine is at normal operating temperature.
3. Set shift lever in "Neutral" position ("N" or "P" position for automatic transmission).
4. Engage parking brake and lock both front and rear wheels with wheel chocks.
5. Measure "CO"% with air cleaner installed.
6. When measuring "CO" percentage, insert probe more than 40 cm (15.7 in) into tailpipe.
7. Make sure fuel pressure regulator control system does not operate.

IDLE SPEED/IGNITION TIMING/IDLE MIXTURE RATIO INSPECTION

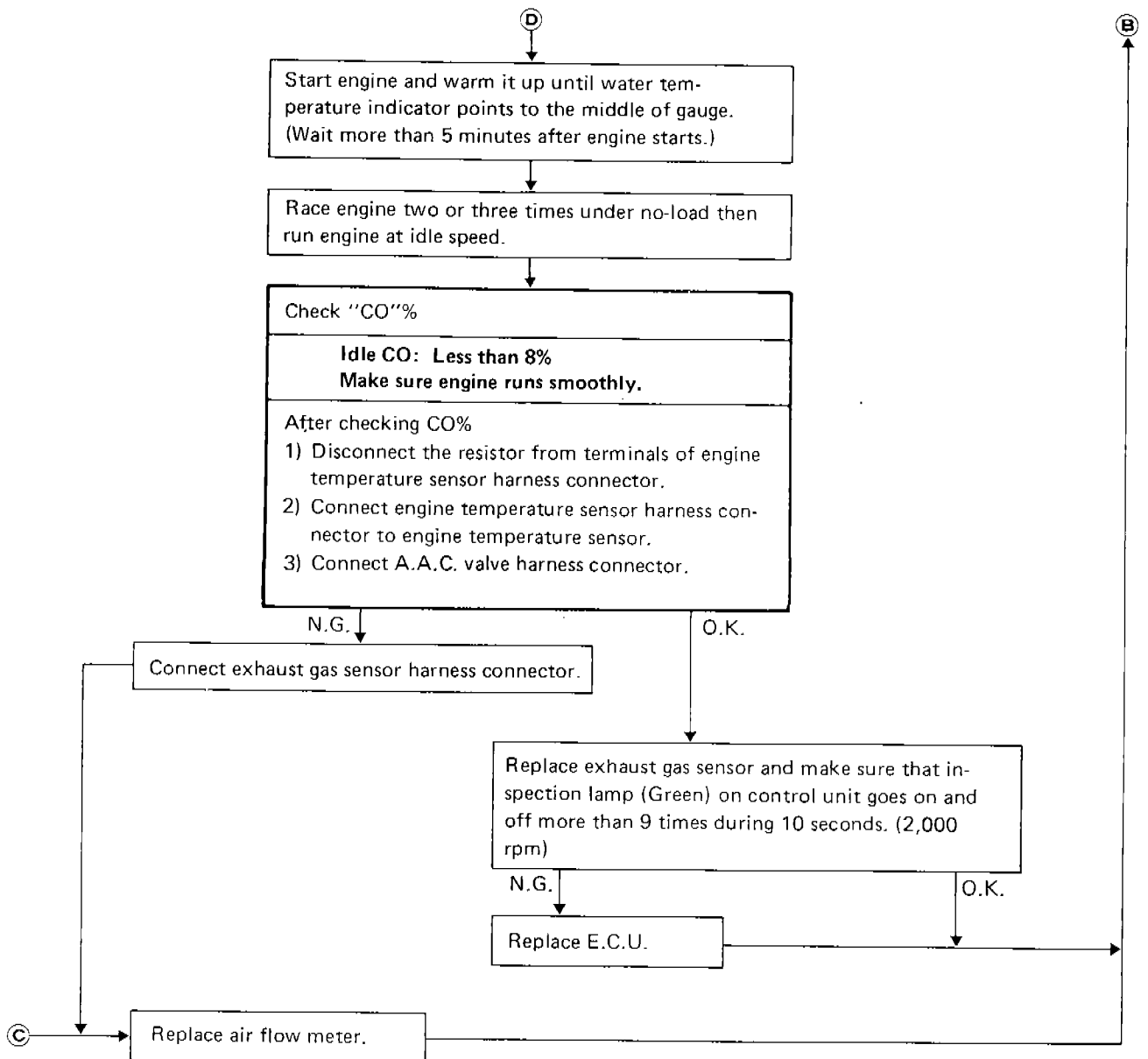

IDLE SPEED/IGNITION TIMING/IDLE MIXTURE RATIO INSPECTION

For non-catalyzer model
[With "CO"-meter]

INSPECTION START

Confirm that engine is at normal operating temperature.

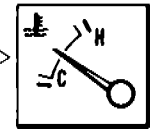

SEF457C

Check and adjust idle speed and ignition timing.

Idle speed: rpm M/T 850±50
A/T 850±50 (in "N" position)
Ignition timing: 15°±2° B.T.D.C.
Refer to page EF & EC-22.

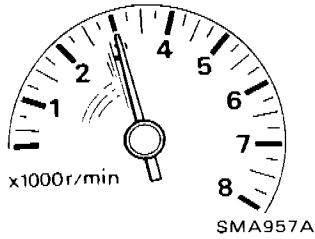

Race engine (2,000 - 3,000 rpm) 2 or 3 times under no-load, then run engine at idle speed.

Check "CO" with "CO"-meter.

Idle "CO" %:
2.0 or lower

O.K.

N.G.

Turn off engine and remove air flow meter from vehicle.

Drill a hole in seal plug which seals air flow meter variable resistor and remove seal plug.

Install air flow meter on vehicle.
Start engine and warm it up until water temperature indicator points to the middle of gauge.

Adjust "CO" % by turning variable resistor on air flow meter.

Idle "CO" %:
2.0 or lower

Race engine two or three times under no-load, then run engine at idle speed.

Check idle speed.

Idle speed: rpm M/T 850±50
A/T 850±50 (in "N" position)

N.G.

O.K.

Stop engine.

INSPECTION END

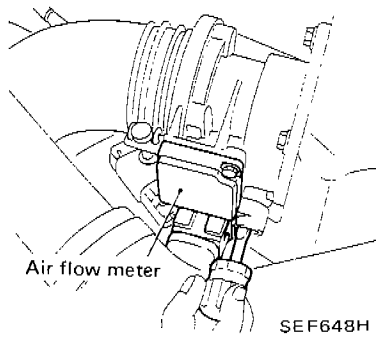

SEF648H

A

B

IDLE SPEED/IGNITION TIMING/IDLE MIXTURE RATIO INSPECTION

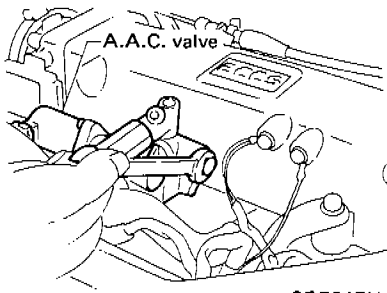

SEF647H

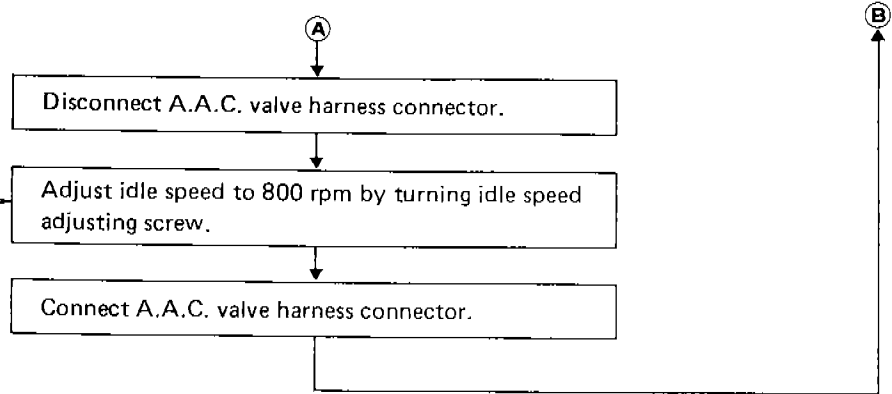

IDLE SPEED/IGNITION TIMING/IDLE MIXTURE RATIO INSPECTION

For non-catalyzer model
[Without "CO"-meter]

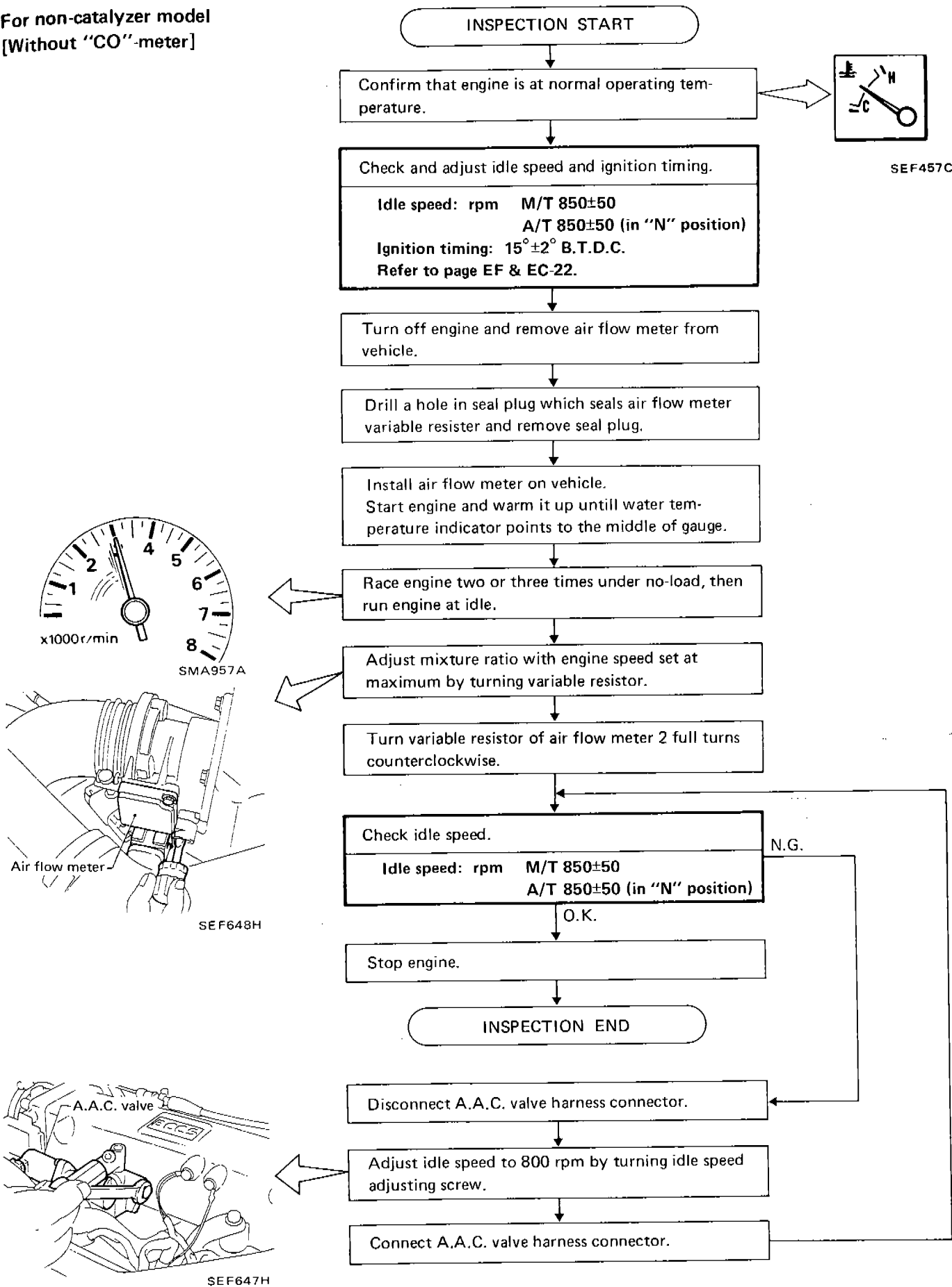

TROUBLE DIAGNOSES

Contents

| | |
|--------------------------------------------------------------------------------------------------|-------------|
| How to Perform Trouble Diagnoses for Quick and Accurate Repair | EF & EC- 34 |
| Diagnostic Table | EF & EC- 38 |
| 1. Impossible to start — no combustion | EF & EC- 39 |
| 2. Impossible to start — partial combustion | EF & EC- 40 |
| 3. Impossible to start — partial combustion (not affected by throttle position) | EF & EC- 41 |
| 4. Impossible to start — partial combustion (throttle position changes combustion quality) | EF & EC- 42 |
| 5. Hard to start — before warm-up | EF & EC- 43 |
| 6. Hard to start — after warm-up | EF & EC- 44 |
| 7. Hard to start — every time | EF & EC- 45 |
| 8. Hard to start — morning after a rainy day | EF & EC- 46 |
| 9. Abnormal idling — no fast idle | EF & EC- 47 |
| 10. Abnormal idling — low idle (after warm-up) | EF & EC- 48 |
| 11. Abnormal idling — high idle (after warm-up) | EF & EC- 49 |
| 12. Unstable idling — before warm-up | EF & EC- 50 |
| 13. Unstable idling — after warm-up | EF & EC- 51 |
| 14. Poor driveability — stumble (while accelerating) | EF & EC- 52 |
| 15. Poor driveability — surge (while cruising) | EF & EC- 53 |
| 16. Poor driveability — lack of power | EF & EC- 54 |
| 17. Poor driveability — detonation | EF & EC- 55 |
| 18. Engine stall — during start-up | EF & EC- 56 |
| 19. Engine stall — while idling | EF & EC- 57 |
| 20. Engine stall — while accelerating | EF & EC- 58 |
| 21. Engine stall — while cruising | EF & EC- 59 |
| 22. Engine stall — while decelerating/just after stopping | EF & EC- 60 |
| 23. Engine stall — while loading | EF & EC- 61 |
| 24. Backfire — through the intake | EF & EC- 62 |
| 25. Backfire — through the exhaust | EF & EC- 63 |
| Self-diagnosis — Description | EF & EC- 64 |
| Self-diagnosis — Mode I & II (Model with catalyzer) | EF & EC- 67 |
| Self-diagnosis — Mode III | EF & EC- 68 |
| Self-diagnosis — Mode IV | EF & EC- 73 |
| Self-diagnosis — Mode V | EF & EC- 75 |
| Diagnostic Procedure | EF & EC- 78 |
| Diagnostic Procedure 1 POWER SOURCE AND GROUND CIRCUIT FOR E.C.U. | EF & EC- 80 |
| Diagnostic Procedure 2 CRANK ANGLE SENSOR | EF & EC- 82 |
| Diagnostic Procedure 3 AIR FLOW METER | EF & EC- 84 |
| Diagnostic Procedure 4 ENGINE TEMPERATURE SENSOR | EF & EC- 86 |
| Diagnostic Procedure 5 VEHICLE SPEED SENSOR | EF & EC- 88 |
| Diagnostic Procedure 6 IGNITION SIGNAL & DETONATION SENSOR | EF & EC- 90 |
| Diagnostic Procedure 7 IDLE SWITCH | EF & EC- 94 |
| Diagnostic Procedure 8 EXHAUST GAS SENSOR | EF & EC- 96 |
| Diagnostic Procedure 9 THROTTLE SENSOR | EF & EC- 98 |
| Diagnostic Procedure 10 FUEL PUMP | EF & EC-102 |
| Diagnostic Procedure 11 START SIGNAL | EF & EC-104 |

TROUBLE DIAGNOSES

Contents (Cont'd)

| | |
|--------------------------------------------------------|-------------|
| Diagnostic Procedure 12 | |
| AUXILIARY AIR CONTROL (A.A.C.) VALVE | EF & EC-106 |
| Diagnostic Procedure 13 | |
| I.A.A. CONTROL (F.I.C.D. CONTROL) | EF & EC-108 |
| Diagnostic Procedure 14 | |
| AIR REGURATOR | EF & EC-110 |
| Diagnostic Procedure 15 | |
| INJECTOR | EF & EC-112 |
| Diagnostic Procedure 16 | |
| PRESSURE REGULATOR (P.R.) CONTROL SOLENOID VALVE | EF & EC-114 |
| Diagnostic Procedure 17 | |
| NEUTRAL AND INHIBITOR SWITCH | EF & EC-116 |
| Diagnostic Procedure 18 | |
| ACCELERATION CUT CONTROL | EF & EC-118 |
| Electrical Components Inspection | EF & EC-119 |

TROUBLE DIAGNOSES

How to Perform Trouble Diagnoses for Quick and Accurate Repair

INTRODUCTION

The engine has an electronic control unit to control major systems such as fuel control, ignition control, idle speed control, etc. The control unit accepts input signals from sensors and instantly drives actuators. It is essential that both kinds of signals are proper and stable. At the same time, it is important that there are no conventional problems such as vacuum leaks, fouled spark plugs, or other problems with the engine.

It is much more difficult to diagnose a problem that occurs intermittently rather than continuously. Most intermittent problems are caused by poor electric connections or faulty wiring. In this case, careful checking of suspicious circuits may help prevent the replacement of good parts.

A visual check only may not find the cause of the problems. A road test with a circuit tester connected to a suspected circuit should be performed.

Before undertaking actual checks, take just a few minutes to talk with a customer who approaches with a driveability complaint. The customer is a very good supplier of information on such problems, especially intermittent ones. Through the talks with the customer, find out what symptoms are present and under what conditions they occur.

Start your diagnosis by looking for "conventional" problems first. This is one of the best ways to troubleshoot driveability problems on an electronically controlled engine vehicle.

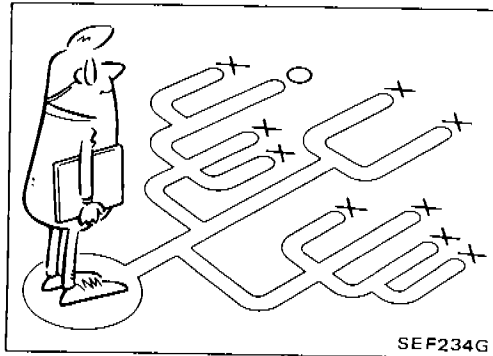
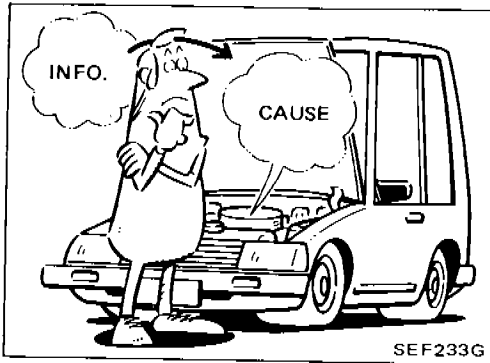
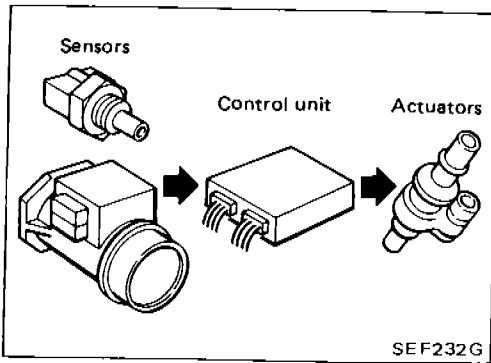

TROUBLE DIAGNOSES

How to Perform Trouble Diagnoses for Quick and Accurate Repair (Cont'd)

WORK FLOW

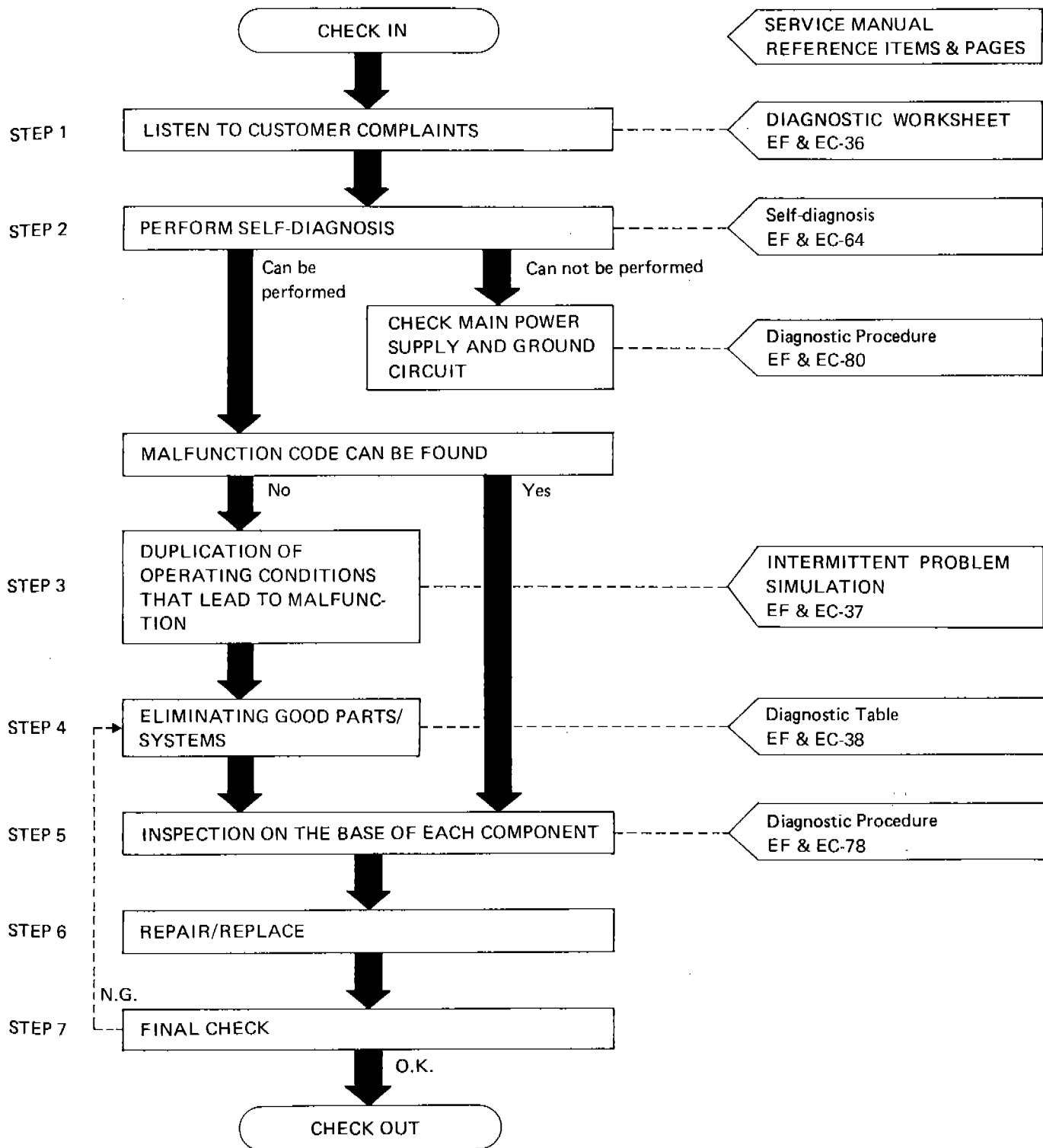

TROUBLE DIAGNOSES

How to Perform Trouble Diagnoses for Quick and Accurate Repair (Cont'd)

INTERMITTENT PROBLEM SIMULATION

In order to duplicate an intermittent problem, it is effective to create similar conditions for component parts, under which the problem might occur.

Perform the activity listed under Service procedure and note the result.

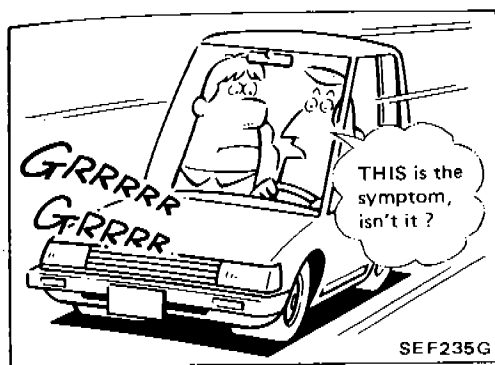

| | Variable factor | Influential part | Target condition | Service procedure |
|----|-------------------------------------------|------------------------------|-------------------------------------------|--------------------------------------------------------------------------------------------|
| 1 | Mixture ratio | Pressure regulator | Made lean | Remove vacuum hose and apply vacuum. |
| | | | Made rich | Remove vacuum hose and apply pressure. |
| 2 | Ignition timing | Crank angle sensor | Advanced | Rotate crank angle sensor counterclockwise. |
| | | | Retarded | Rotate crank angle sensor clockwise. |
| 3* | Mixture ratio feedback control | Exhaust gas sensor | Suspended | Disconnect exhaust gas sensor harness connector. |
| | | Control unit | Operation check | Perform self-diagnosis (Mode I/II) at 2,000 rpm. |
| 4 | Idle speed | I.A.A. unit | Raised | Turn idle adjust screw counterclockwise. |
| | | | Lowered | Turn idle adjust screw clockwise. |
| 5 | Electric connection (Electric continuity) | Harness connectors and wires | Poor electric connection or faulty wiring | Tap or wiggle. |
| | | | | Race engine rapidly. See if the torque reaction of the engine unit causes electric breaks. |
| 6 | Temperature | Control unit | Cooled | Cool with an icing spray or similar device. |
| | | | Warmed | Heat with a hair drier. [WARNING: Do not overheat the unit.] |
| 7 | Moisture | Electric parts | Damp | Wet [WARNING: Do not directly pour water on components. Use a mist sprayer.] |
| 8 | Electric loads | Load switches | Loaded | Turn on head lights, air conditioner, rear defogger, etc. |
| 9 | Idle switch condition | Control unit | ON-OFF switching | Perform self-diagnosis (Mode IV). |
| 10 | Ignition spark | Timing light | Spark power check | Try to flash timing light for each cylinder. |

*For catalyzer model

TROUBLE DIAGNOSES

Diagnostic Table

To assist with your trouble diagnoses, some typical diagnostic procedures for the following symptoms are described.

REMARKS

In the following pages, the numbers such as ①, ② in the above chart correspond to those in the service procedure described below.

Possible causes can be checked through the service procedure shown by the mark "○".

TROUBLE DIAGNOSES

Diagnostic Table (Cont'd)

SYMPTOM & CONDITION 1 Impossible to start – no combustion

| POSSIBLE CAUSES | | 1 | 2 | 3 | 4 | 5 | 6 | 7 |
|-----------------|-----------------------------------|---|---|---|---|---|---|---|
| SPECIFICATIONS | Mixture ratio (too lean) | ○ | ○ | | | | | |
| | Ignition sparks (weak, missing) | | | | ○ | ○ | | |
| | Ignition timing | | | | | | ○ | |
| FUEL SYSTEM | Fuel pump (no operation) | ○ | | | | | | |
| | Fuel pump relay (open circuited) | ○ | | | | | | |
| | Injectors (no operation, clogged) | | ○ | | | | | |
| IGNITION SYSTEM | Ignition switch | ○ | ○ | ○ | ○ | | ○ | |
| | E.C.C.S. relay | ○ | ○ | ○ | ○ | | ○ | |
| | Power transistor | | | ○ | ○ | | ○ | |
| | Ignition coil | | | | ○ | | ○ | |
| | Spark plugs | | | | | ○ | | |
| CONTROL SYSTEM | Crank angle sensor | ○ | ○ | | ○ | | ○ | ○ |

SERVICE PROCEDURE

1 LISTEN

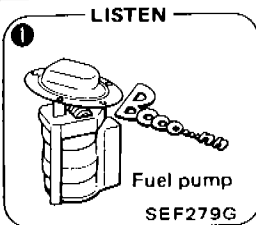

Fuel pump
SEF279G

Listen for fuel pump operating sound.

N.G. → Check fuel pump and/or related circuits. [See page EF & EC-102.]

2 LISTEN

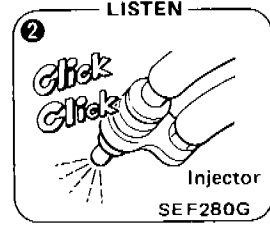

Injector
SEF280G

Listen for injector operating sound.

N.G. → Check injector circuit. [See page EF & EC-112.]

3 CHECK

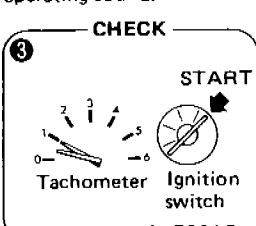

Tachometer Ignition switch
SEF281G

Make sure tachometer needle moves when cranking.

N.G. →

4 CHECK

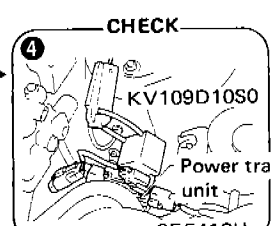

Power transistor unit
SEF418H

Check flashes of timing light for weakness.

N.G. → Check ignition signal circuit. [See page EF & EC-90.]

5 CHECK

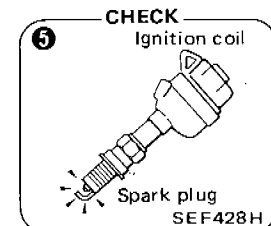

Spark plug
SEF428H

Remove spark plugs and check their ignition sparks.

6 CHECK

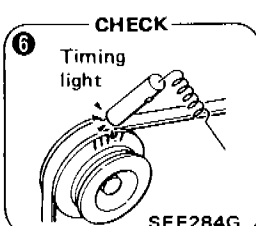

Timing light
SEF284G

Check ignition timing.

N.G. → Adjust ignition timing. [See page EF & EC-22.]

7 PERFORM

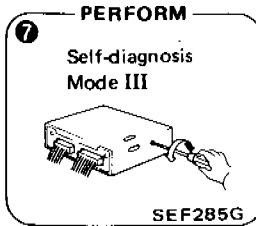

Self-diagnosis Mode III
SEF285G

Perform self-diagnosis Mode III (for crank angle sensor).

N.G. → Check crank angle sensor and/or related circuits. [See page EF & EC-82.]

TROUBLE DIAGNOSES

Diagnostic Table (Cont'd)

SYMPTOM & CONDITION 2 Impossible to start — partial combustion

| POSSIBLE CAUSES | | 1 | 2 | 3 | 4 | 5 |
|-----------------|----------------------------------|---|---|---|---|---|
| SPECIFICATIONS | Mixture ratio | ○ | ○ | ○ | | |
| | Fuel pressure (too low) | | | | ○ | |
| | Ignition timing | | | | | ○ |
| FUEL SYSTEM | Fuel pump | ○ | | | | |
| | Fuel pump relay (open circuited) | ○ | | | | |
| | Injectors (clogged) | | ○ | | | |

SERVICE PROCEDURE

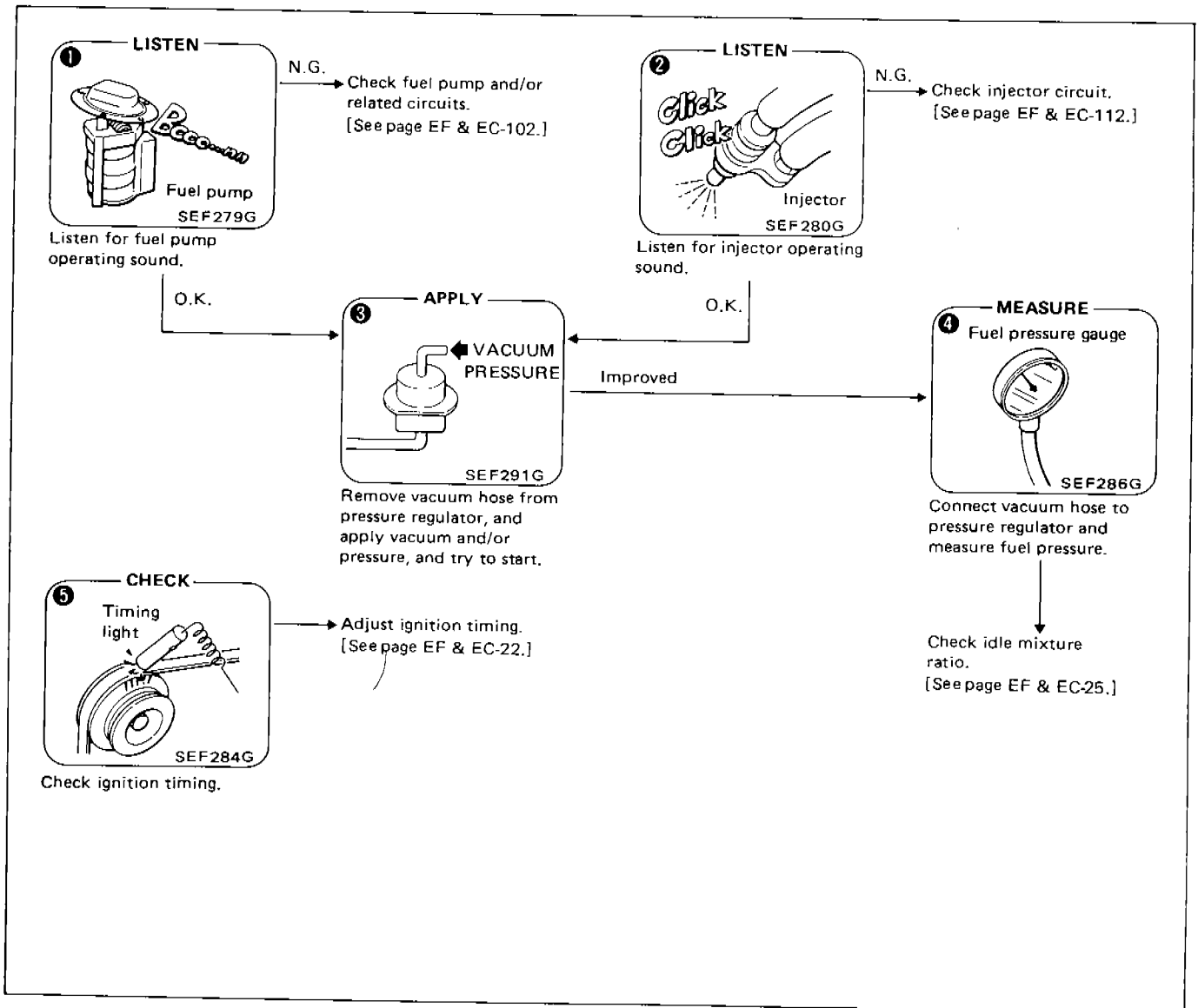

TROUBLE DIAGNOSES

Diagnostic Table (Cont'd)

SYMPTOM & CONDITION 3 Impossible to start – partial combustion (not affected by throttle position)

| POSSIBLE CAUSES | | 1 | 2 | 3 | 4 | 5 | 6 | 7 | 8 | 9 | 10 | 11 |
|-----------------|------------------------------------------|---|---|---|---|---|---|---|---|---|----|----|
| SPECIFICATIONS | Mixture ratio | ○ | | ○ | ○ | | | | | | | |
| | Fuel pressure (too low) | | | ○ | ○ | ○ | | | | | | |
| | Ignition timing | | | | | | ○ | | | | | |
| FUEL SYSTEM | Fuel filter (clogged) | | | | | ○ | | | | | | |
| | Fuel line (clogged) | | | | | ○ | | | | | | |
| | Injectors (clogged) | ○ | | | | | | | | | | |
| | Pressure regulator | | | | ○ | | | | | | | |
| | Pressure regulator vacuum hose (clogged) | | | ○ | | | | | | | | |
| IGNITION SYSTEM | Spark plugs (wet with fuel) | | | | | | | ○ | | ○ | | |
| | Ignition switch | ○ | | | | | | ○ | | ○ | | |
| INTAKE SYSTEM | Throttle chamber (with ports clogged) | | ○ | | | | | | | | | |
| | Throttle valve (clogged) | | ○ | | | | | | | | | |
| CONTROL SYSTEM | Engine temperature sensor | | | | | | | | | | ○ | ○ |
| | Crank angle sensor | ○ | | | | | | ○ | | | ○ | |

SERVICE PROCEDURE

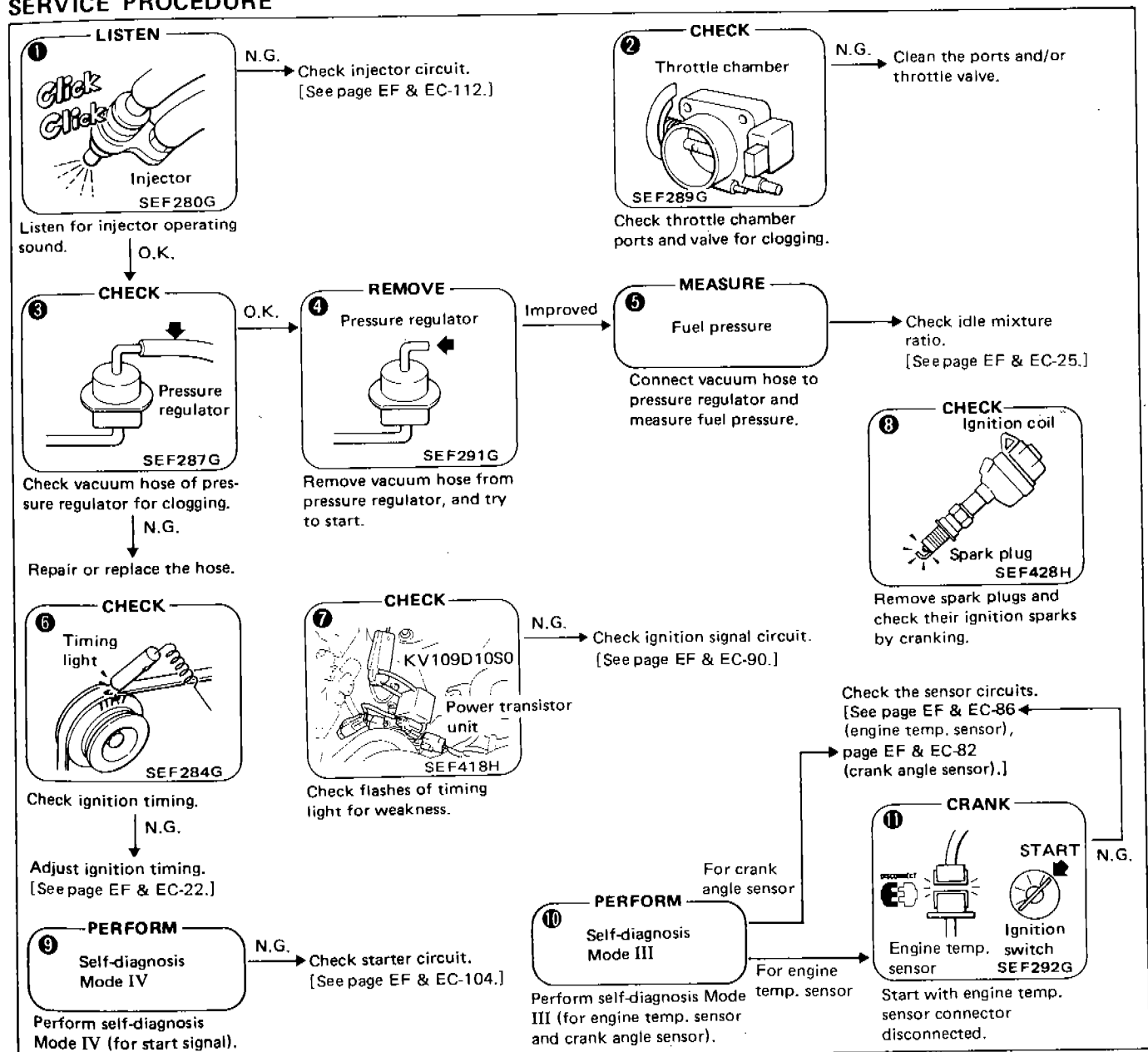

TROUBLE DIAGNOSES

Diagnostic Table (Cont'd)

SYMPTOM & CONDITION **4** Impossible to start — partial combustion (throttle position changes combustion quality)

| POSSIBLE CAUSES | | 1 | 2 | 3 | 4 | 5 |
|-----------------------|---------------------------------------|---|---|---|---|---|
| INTAKE SYSTEM | Throttle chamber (with ports clogged) | ○ | | | | |
| | Throttle valve (clogged) | | ○ | | | |
| | Air regulator (stuck closed) | | | ○ | | |
| CONTROL SYSTEM | Engine temperature sensor | | | | ○ | |
| | Idle switch | | | | ○ | |
| | Neutral switch | | | | | ○ |

SERVICE PROCEDURE

1 CHECK

Throttle chamber

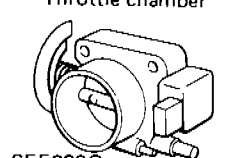

SEF289G

Check throttle chamber ports for clogging.

N.G. → Clean the ports.

2 CHECK

Throttle chamber

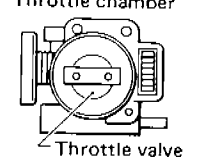

SEF290G

Check throttle valve for clogging.

N.G. → Clean the valve.

3 CHECK

Air regulator

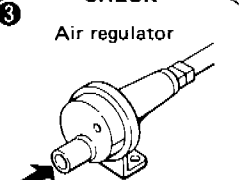

SEF293G

Make sure air regulator stays open before warm-up

N.G. → Check air regulator and/or its circuit.
[See page EF & EC-110.]

4 PERFORM

Self-dagnosis Mode III/IV

Perform self-diagnosis Mode III (for engine temp. sensor), Mode IV (for idle switch).

5 CHECK

Tachometer Ignition switch

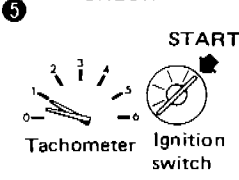

SEF281G

Make sure tachometer indicates about 300 rpm while cranking.

N.G. → Check neutral switch and/or its circuit
[See page EF & EC-116.]

TROUBLE DIAGNOSES

Diagnostic Table (Cont'd)

SYMPTOM & CONDITION 5 **Hard to start – before warm-up**

| POSSIBLE CAUSES | | 1 | 2 | 3 | 4 | 5 | 6 |
|-----------------|-----------------------------------|---|---|---|---|---|---|
| SPECIFICATIONS | Mixture ratio | | | ○ | | | ○ |
| IGNITION SYSTEM | Ignition switch (no start signal) | ○ | | | ○ | | |
| INTAKE SYSTEM | Air regulator | | | ○ | | | |
| CONTROL SYSTEM | Engine temperature sensor | | | | | ○ | ○ |
| | Idle switch | | | | ○ | | |
| | Neutral switch | ○ | | | | | |
| OTHERS | Starter (operation too slow) | ○ | | | | | |
| | Battery (voltage too low) | ○ | ○ | | | | |

SERVICE PROCEDURE

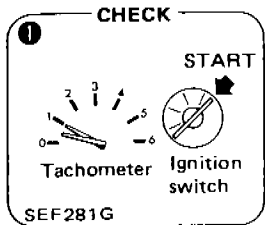

Make sure tachometer indicates about 300 rpm while cranking.

N.G.

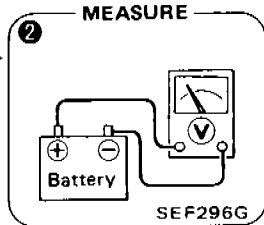

Measure battery voltage.

N.G. (less than 12V)

Charge the battery.

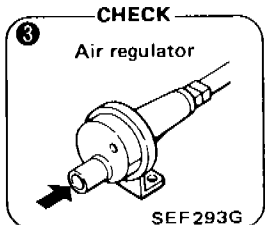

Make sure air regulator stays open before warm-up.

N.G.

Check air regulator and/or its circuit.
[See page EF & EC-110.]

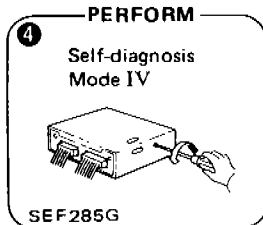

Perform self-diagnosis Mode IV (for start signal and idle switch).

N.G.

Check the malfunctioning switches and/or circuits.
[See page EF & EC-104 (start signal), page EF & EC-94 (idle switch).]



Perform self-diagnosis Mode III (for engine temp. sensor).

N.G.

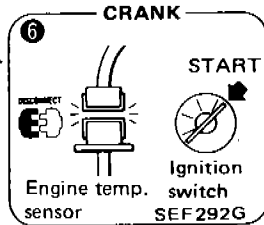

Start with engine temp. sensor connector disconnected.

N.G.

Check sensor circuit.
[See page EF & EC-86 (engine temp. sensor).]

TROUBLE DIAGNOSES

Diagnostic Table (Cont'd)

SYMPTOM & CONDITION **6** Hard to start — after warm-up

| POSSIBLE CAUSES | | 1 | 2 | 3 | 4 | 5 | 6 | 7 | 8 |
|-----------------|-------------------------------------------------|---|---|---|---|---|---|---|---|
| SPECIFICATIONS | Mixture ratio | | | ○ | | | ○ | | |
| | Fuel pressure | | | ○ | | | ○ | ○ | |
| FUEL SYSTEM | Fuel line (hot fuel) | | | ○ | | | | | |
| | Pressure regulator (low fuel pressure) | | | | | | ○ | | |
| | Pressure regulator vacuum hose (clogged) | | | | | | ○ | | |
| | Pressure regulator control solenoid | | | | | | | ○ | ○ |
| | Pressure regulator control solenoid vacuum hose | | | | | | ○ | | |
| IGNITION SYSTEM | Ignition switch (no start signal) | ○ | | | | ○ | | | |
| CONTROL SYSTEM | Engine temperature sensor | | | | ○ | | | | |
| | Air flow meter | | | | ○ | | | | |
| OTHERS | Starter (operation too slow) | ○ | | | | | | | |
| | Battery (voltage too low) | ○ | ○ | | | | | | |

SERVICE PROCEDURE

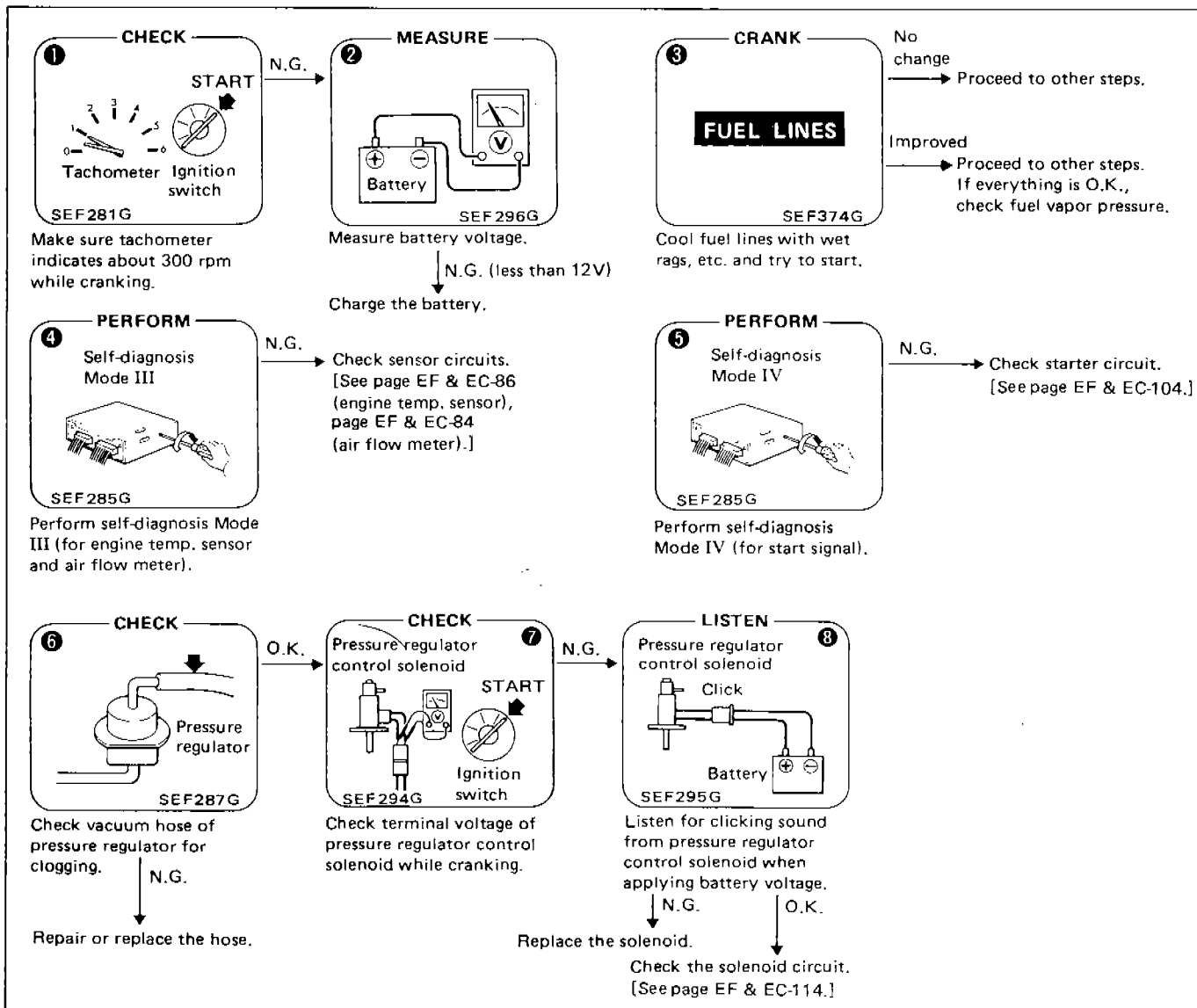

TROUBLE DIAGNOSES

Diagnostic Table (Cont'd)

SYMPTOM & CONDITION 7 **Hard to start – every time**

| POSSIBLE CAUSES | | 1 | 2 | 3 | 4 | 5 | 6 | 7 | 8 | 9 | 10 | 11 |
|-----------------|----------------------------------------|---|---|---|---|---|---|---|---|---|----|----|
| SPECIFICATIONS | Mixture ratio | ○ | | | | ○ | ○ | | | | | |
| | Fuel pressure | | | | | | ○ | ○ | | | | |
| | Ignition sparks (missing) | | | | | | | | ○ | | ○ | |
| | Ignition timing | | | | ○ | | | | | | | |
| FUEL SYSTEM | Fuel pump (improper operation) | ○ | | | | | | | | | | |
| | Fuel line (clogged) | | | | | | | ○ | | | | |
| | Canister (air leaks) | | | | | ○ | | | | | | |
| | Pressure regulator (low fuel pressure) | | | | | | ○ | | | | | |
| IGNITION SYSTEM | Spark plugs (improper gap) | | | | | | | | | ○ | | |
| CONTROL SYSTEM | Crank angle sensor | ○ | | | | | | | ○ | | | ○ |
| | Engine temperature sensor | | | | | | | | | | | ○ |
| | Idle switch | | | | | | | | | | | ○ |
| | Neutral switch | | ○ | | | | | | | | | |
| OTHERS | Starter (operation too slow) | | ○ | | | | | | | | | |
| | Battery (voltage too low) | | ○ | ○ | | | | | | | | |

SERVICE PROCEDURE

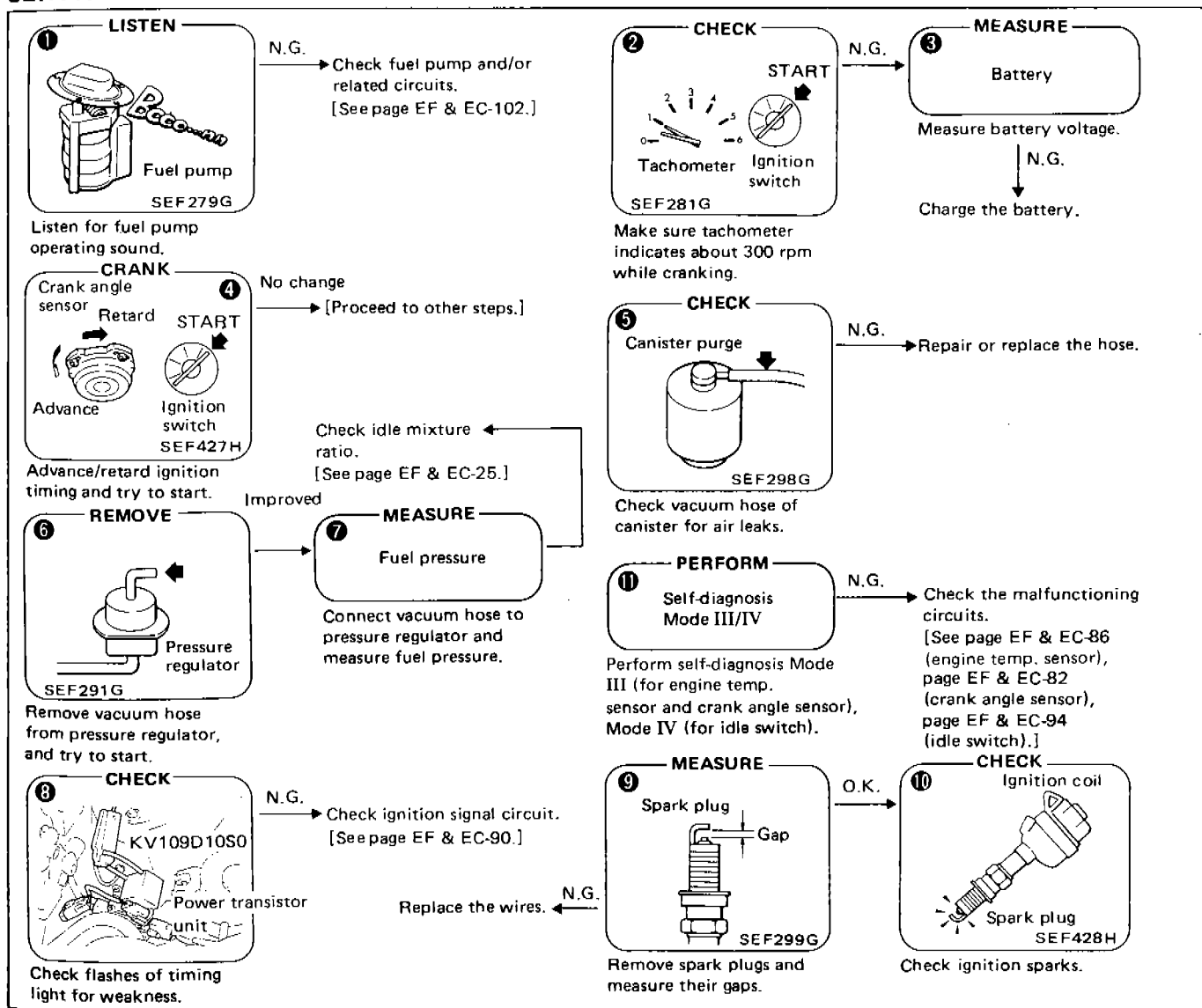

TROUBLE DIAGNOSES

Diagnostic Table (Cont'd)

SYMPTOM & CONDITION 8 **Hard to start – morning after a rainy day**

| POSSIBLE CAUSES | | 1 | 2 | 3 | 4 |
|-----------------|----------------------------|---|---|---|---|
| SPECIFICATIONS | Ignition sparks (weak) | ○ | | | ○ |
| IGNITION SYSTEM | Power transistor | ○ | | | ○ |
| | Ignition coil | ○ | ○ | | ○ |
| | Spark plugs (improper gap) | | | ○ | ○ |

SERVICE PROCEDURE

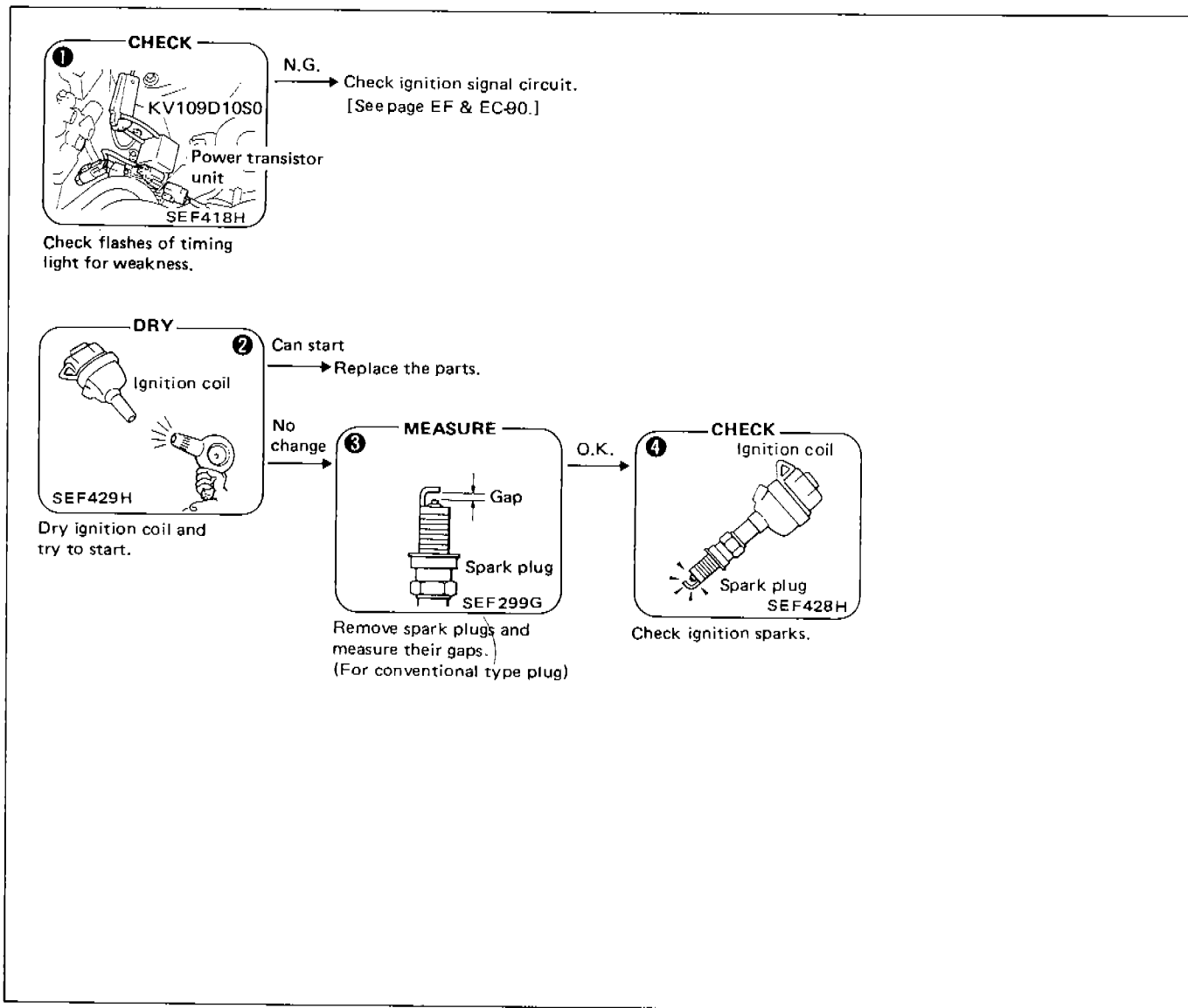

TROUBLE DIAGNOSES

Diagnostic Table (Cont'd)

SYMPTOM & CONDITION **9** **Abnormal idling – no fast idle**

| POSSIBLE CAUSES | | 1 | 2 | 3 | 4 | 5 | 6 |
|-----------------------|------------------------------|---|---|---|---|---|---|
| SPECIFICATIONS | Mixture ratio | ○ | ○ | | ○ | | |
| | Ignition timing | | | ○ | | | |
| INTAKE SYSTEM | Blow-by hose (clogged) | | ○ | | | | |
| | Air regulator (stuck closed) | ○ | | | | | |
| CONTROL SYSTEM | Engine temperature sensor | | | | | ○ | ○ |

SERVICE PROCEDURE

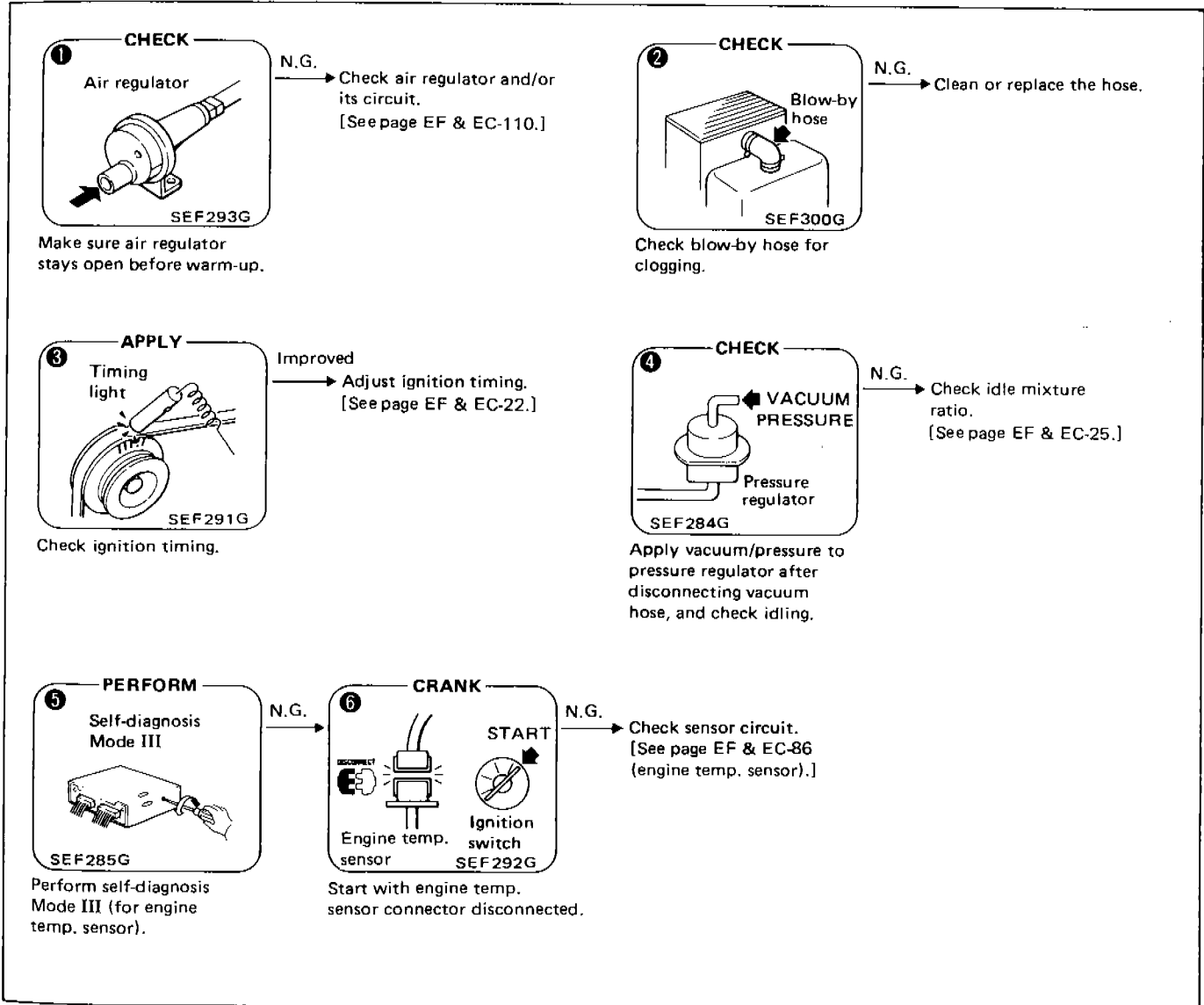

TROUBLE DIAGNOSES

Diagnostic Table (Cont'd)

SYMPTOM & CONDITION 10 Abnormal idling – low idle (after warm-up)

| POSSIBLE CAUSES | | 1 | 2 | 3 | 4 | 5 | 6 | 7 |
|-----------------|---------------------------------------|---|---|---|---|---|---|---|
| SPECIFICATIONS | Mixture ratio | | ○ | | | ○ | | |
| | Ignition timing (too retarded) | ○ | | | | | | |
| INTAKE SYSTEM | Throttle chamber (with ports clogged) | | | ○ | | | | |
| | Throttle valve (clogged) | | | | ○ | | | |
| CONTROL SYSTEM | Crank angle sensor | | | | | | ○ | |
| | Air flow meter | | | | | | ○ | |
| | Engine temperature sensor | | | | | | ○ | ○ |

SERVICE PROCEDURE

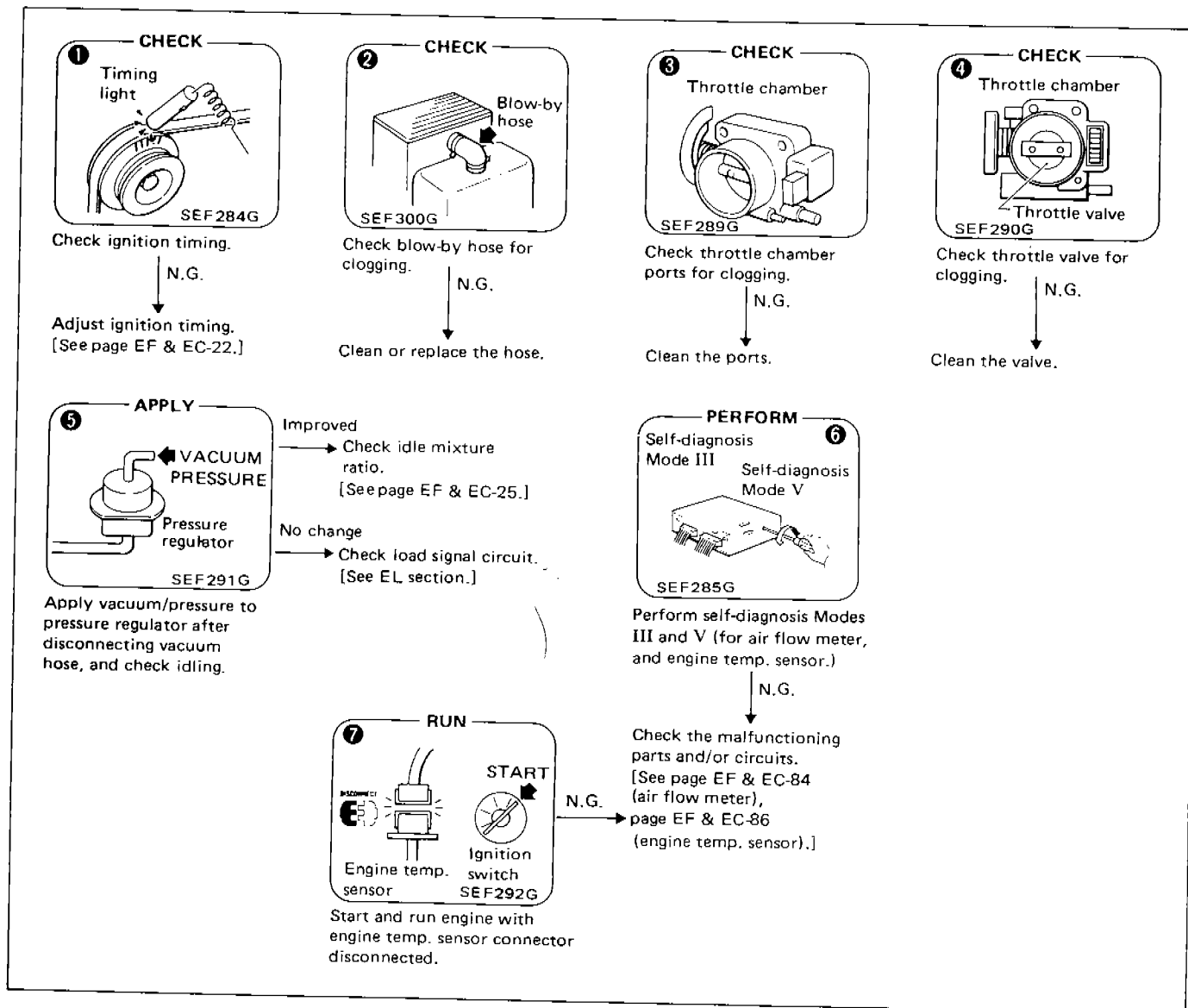

TROUBLE DIAGNOSES

Diagnostic Table (Cont'd)

SYMPTOM & CONDITION 11 Abnormal idling – high idle (after warm-up)

| POSSIBLE CAUSES | | 1 | 2 | 3 | 4 | 5 | 6 | 7 | 8 | 9 | 10 | 11 |
|-----------------|--------------------------------------|---|---|---|---|---|---|---|---|---|----|----|
| SPECIFICATIONS | Mixture ratio | | ○ | ○ | | ○ | ○ | | | ○ | | |
| | Ignition timing (too advanced) | ○ | | | | | | | | | | |
| INTAKE SYSTEM | Air duct (leaks) | | ○ | | | | | | | | | |
| | Throttle chamber (air leaks) | | | | ○ | | | | | | | |
| | Throttle valve (stuck control wire) | | | | ○ | | | | | | | |
| | Intake manifold (gasket) (air leaks) | | ○ | | | | | | | | | |
| | Air regulator (stuck open) | | | ○ | | | | | | | | |
| | A.A.C. valve | | | | | | | ○ | | | | |
| | F.I.C.D. solenoid (remaining ON) | | | | | | | | ○ | | | |
| CONTROL SYSTEM | Crank angle sensor | | | | | | | | | | ○ | |
| | Air flow meter | | | | | | | | | | ○ | |
| | Engine temperature sensor | | | | | | | | | ○ | ○ | |
| | Idle switch (remaining OFF) | | | | | | | ○ | | ○ | | |
| OTHERS | Battery (voltage too low) | | | | | | | | | | | |

SERVICE PROCEDURE

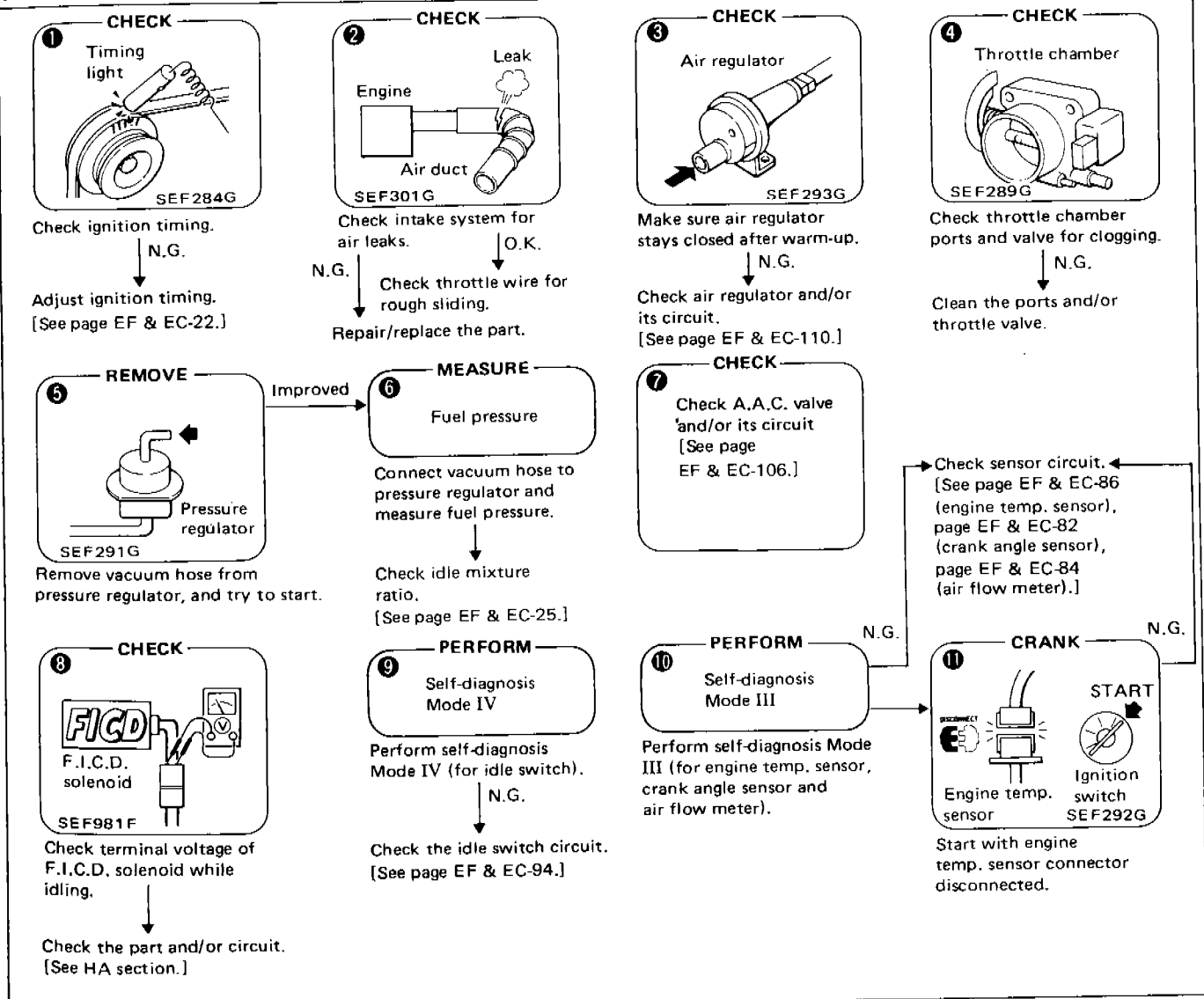

TROUBLE DIAGNOSES

Electrical Components Inspection (Cont'd) INJECTOR

1. Disconnect injector harness connector.
2. Check injector resistance.

Resistance:

2 - 3 Ω

3. Remove injector and check nozzle for clogging if necessary.

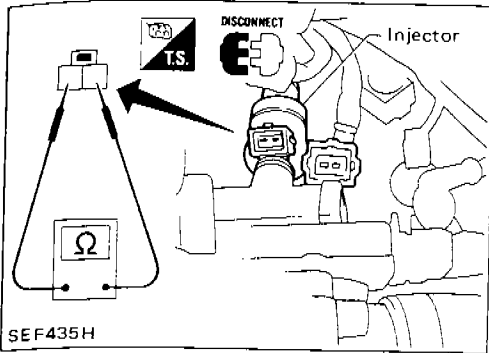

SEF435H

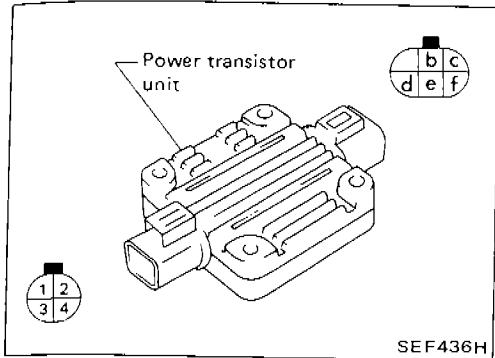

SEF436H

POWER TRANSISTOR

1. Disconnect power transistor harness connectors.
2. Check continuity between terminals as shown below:

| Terminal combination | | | | Tester polarity | Continuity | Tester polarity | Continuity |
|----------------------|---|---|---|-----------------------|------------|-----------------------|------------|
| 1 | 2 | 3 | 4 | \oplus \ominus | Yes | \oplus \ominus | No |
| 1 | 2 | 3 | 4 | \oplus \ominus | Yes | \oplus \ominus | No |
| d | d | d | d | \oplus \ominus | Yes | \oplus \ominus | Yes |

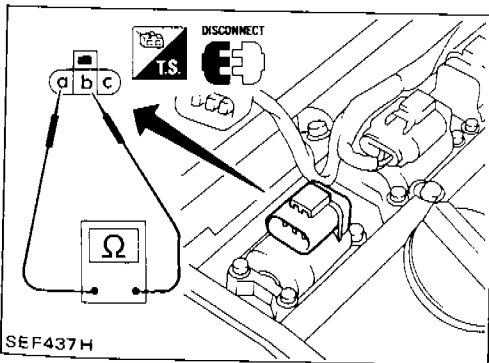

SEF437H

IGNITION COIL

1. Disconnect ignition coil harness connector.
2. Check resistance between terminals \textcircled{a} and \textcircled{b} .

Resistance:

0.6 - 0.8 Ω

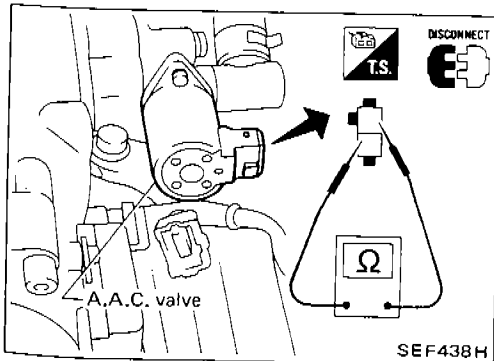

SEF438H

A.A.C. VALVE

1. Disconnect A.A.C. valve harness connector.
2. Check A.A.C. valve resistance.

Resistance:

Approximately 9 - 10 Ω

TROUBLE DIAGNOSES

Electrical Components Inspection (Cont'd) CRANK ANGLE SENSOR

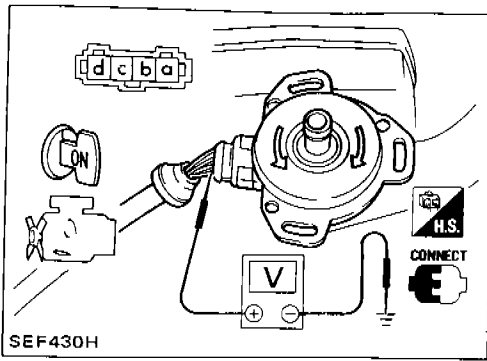

1. Remove crank angle sensor from engine.
2. Check voltage between terminal (a) and ground, and terminal (b) and ground while rotating the crank angle sensor shaft as shown. At this time make sure that injectors operating sound can be heard.

Voltage:

0V and approximately 5V appear alternately.

After this inspection, malfunction code No. 11 might be displayed though the crank angle sensor is functioning properly. In this case erase the stored memory.

AIR FLOW METER

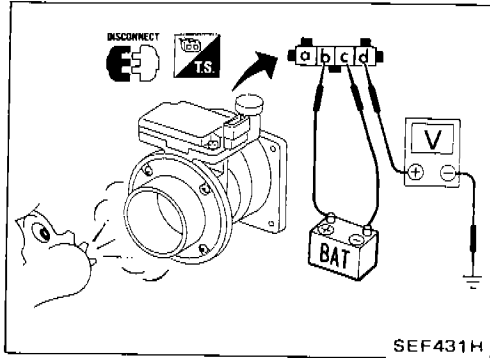

1. Remove air flow meter from vehicle and visually check hot wire air passage for dust.
2. Supply battery voltage between terminals (b) and (c).
3. Check voltage between terminal (d) and ground while blowing air flow meter as shown.

Voltage:

When blowing Approximately 2V

Not blowing Approximately 1V

IDLE SWITCH

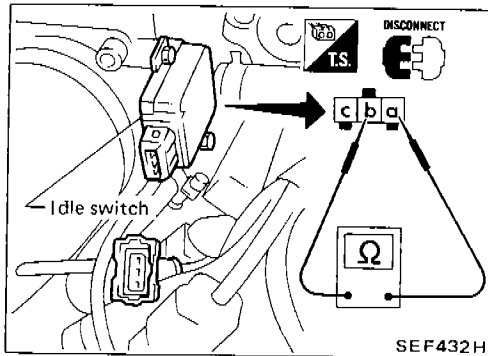

1. Disconnect idle switch harness connector.
2. Check continuity between terminals (a) and (b).

| Accelerator pedal | Continuity |
|---------------------|------------|
| Completely released | Yes |
| Depressed | No |

THROTTLE SENSOR

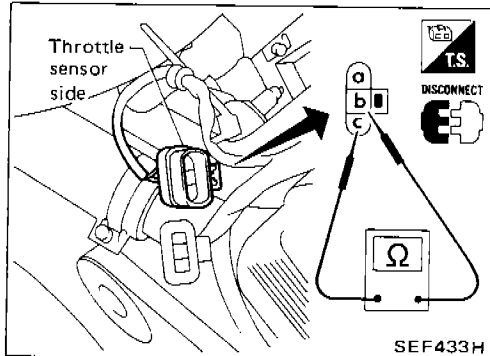

1. Disconnect throttle sensor harness connector.
2. Make sure that resistance between terminals (b) and (c) changes when opening throttle valve manually.

| Accelerator pedal | Resistance |
|----------------------|--------------------|
| Completely released | Approximately 1 kΩ |
| Partially depressed | 1 - 9 kΩ |
| Completely depressed | Approximately 9 kΩ |

ENGINE TEMPERATURE SENSOR

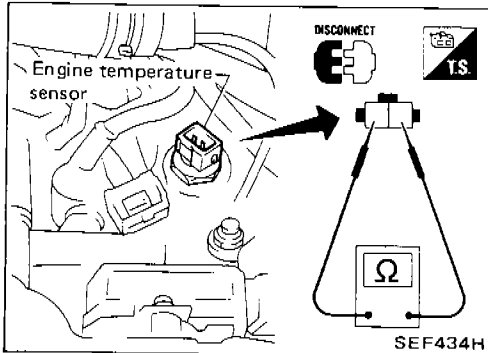

1. Disconnect engine temperature sensor harness connector.
2. Check engine temperature sensor resistance.

| Temperature °C (°F) | Resistance (kΩ) |
|---------------------|-----------------|
| 20 (68) | Approx. 2.5 |
| 80 (176) | Approx. 0.3 |

TROUBLE DIAGNOSES

Electrical Components Inspection (Cont'd)

*Data are reference values.

| TERMI- NAL NO. | ITEM | CONDITION | DATA* |
|----------------------|-----------------------------------------------------|------------------------------------------------------------------------------------------------------------------------------------|-------------------------------|
| 111 | Pressure regulator (P.R.) control solenoid valve | Ignition switch "ON" └─ For approximately 3 minutes after starting engine. Water temperature is above 60°C (140°F). | 0.8 - 1.0V |
| | | Ignition switch "ON" └─ In approximately 3 minutes after starting engine. [Water temperature is above 60°C (140°F).] | BATTERY VOLTAGE (11 - 14V) |
| | | Ignition switch "ON" or "START". [Water temperature is below 60°C (140°F).] | |

E.C.U. pin connector terminal layout

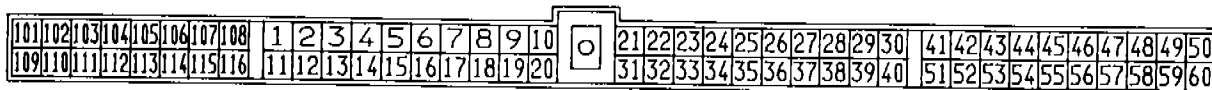

SEF424H

TROUBLE DIAGNOSES

Electrical Components Inspection (Cont'd)

*Data are reference values.

| TERMI- NAL NO. | ITEM | CONDITION | DATA* |
|----------------------|-----------------------------------------|-------------------------------------------------------------------------------------------------------------------------------------------------------|-------------------------------|
| 49 59 | Power source for E.C.U. | Ignition switch "ON" | BATTERY VOLTAGE (11 - 14V) |
| 54 | Idle switch (⊖ side) | Ignition switch "ON" └ Throttle valve: idle position | Approximately 8 - 10V |
| | | Ignition switch "ON" └ Throttle valve: Any position except idle position | 0V |
| 57 | Idle switch (⊕ side) | Ignition switch "ON" └ Throttle valve: idle position | Approximately 8 - 10V |
| | | Ignition switch "ON" └ Throttle valve: Any position except idle position | BATTERY VOLTAGE (11 - 14V) |
| 58 | Power source (Back-up) | Ignition switch "OFF" | BATTERY VOLTAGE (11 - 14V) |
| 101 | Injector No. 1 | Engine is running. | BATTERY VOLTAGE (11 - 14V) |
| 103 | Injector No. 3 | | |
| 110 | Injector No. 2 | | |
| 112 | Injector No. 4 | | |
| 106 | Auxiliary air control (A.A.C.) valve | Engine is running. └ Idle speed | 8 - 12V |
| | | Engine is running. └ Steering wheel is turned. └ Air conditioner is operating. └ Rear defogger is "ON". └ Headlamps are in high position. | 6 - 8V |

TROUBLE DIAGNOSES

Electrical Components Inspection (Cont'd)

*Data are reference values.

| TERMI- NAL NO. | ITEM | CONDITION | DATA* |
|----------------------|------------------------------------------|-------------------------------------------------------------------------------------------------------------------------------------------------------------------------------------------------------------------------------------------------------------------------------------------------------------------------------------------------------------------------------------|----------------------------------------------------------------------------|
| 27 | Air flow meter | <div style="border: 1px solid black; padding: 2px; display: inline-block;">Engine is running.</div> <ul style="list-style-type: none"> └ Idle speed └ Engine speed is approximately 2,500 rpm. | 1.6V 2.2V Output voltage varies with engine revolution. |
| 28 | Engine temperature sensor | <div style="border: 1px solid black; padding: 2px; display: inline-block;">Engine is running.</div> | 1.0 - 5.0V Output voltage varies with engine coolant temperature. |
| 29 | Exhaust gas sensor | <div style="border: 1px solid black; padding: 2px; display: inline-block;">Engine is running.</div> <ul style="list-style-type: none"> └ After warming up sufficiently | 0 - Approximately 1.0V |
| 38 | Throttle sensor | <div style="border: 1px solid black; padding: 2px; display: inline-block;">Ignition switch "ON"</div> | 0.5 - 4.0V Output voltage varies with the throttle valve opening angle. |
| 41 51 | Crank angle sensor (Reference signal) | <div style="border: 1px solid black; padding: 2px; display: inline-block;">Engine is running.</div> Do not run engine at high speed under no-load. | 0.6 - 0.8V |
| 42 52 | Crank angle sensor (Position signal) | <div style="border: 1px solid black; padding: 2px; display: inline-block;">Engine is running.</div> Do not run engine at high speed under no-load. | 2.0 - 2.6V |
| 43 | Start signal | Cranking | 8 - 12V |
| 44 | Neutral switch & Inhibitor switch | <div style="border: 1px solid black; padding: 2px; display: inline-block;">Ignition switch "ON"</div> <ul style="list-style-type: none"> └ Neutral/Parking <div style="border: 1px solid black; padding: 2px; display: inline-block; margin-top: 5px;">Ignition switch "ON"</div> <ul style="list-style-type: none"> └ Except the above gear position | 0V 4 - 5V |
| 45 | Ignition switch | <div style="border: 1px solid black; padding: 2px; display: inline-block;">Ignition switch "OFF"</div> <div style="border: 1px solid black; padding: 2px; display: inline-block; margin-top: 5px;">Ignition switch "ON"</div> | 0V BATTERY VOLTAGE (11 - 14V) |
| 46 | Air conditioner | <div style="border: 1px solid black; padding: 2px; display: inline-block;">Engine is running.</div> <ul style="list-style-type: none"> └ Both air conditioner switch and blower switch are "ON". | 0V |

TROUBLE DIAGNOSES

Electrical Components Inspection (Cont'd)

E.C.U. INPUT/OUTPUT SIGNAL INSPECTION

E.C.U. inspection table

*Data are reference values.

| TERMI- NAL NO. | ITEM | CONDITION | DATA* |
|----------------------|------------------------------------|-------------------------------------------------------------------------------------------------------------------------------------------------------------|-------------------------------|
| 1 | Ignition signal for No. 1 cylinder | | |
| 2 | Ignition signal for No. 2 cylinder | <div style="border: 1px solid black; padding: 2px; display: inline-block;">Engine is running.</div> └ Idle speed | 0.06V |
| 3 | Ignition signal for No. 3 cylinder | <div style="border: 1px solid black; padding: 2px; display: inline-block;">Engine is running.</div> └ Engine speed is approximately 2,500 rpm. | 0.12 - 0.13V |
| 11 | Ignition signal for No. 4 cylinder | | |
| 6 | Air conditioner relay | A/C switch "OFF" | BATTERY VOLTAGE (11 - 14V) |
| | | A/C switch "ON" | 0 - 1.0V |
| 7 | Tachometer | <div style="border: 1px solid black; padding: 2px; display: inline-block;">Engine is running.</div> └ Idle speed | 0.9V |
| | | <div style="border: 1px solid black; padding: 2px; display: inline-block;">Engine is running.</div> └ Engine speed is approximately 2,500 rpm. | 1.7V |
| 16 | E.C.C.S. relay | Ignition switch "ON" | 0 - 1.0V |
| | | Ignition switch "OFF" | BATTERY VOLTAGE (11 - 14V) |
| 18 | Fuel pump relay | <div style="border: 1px solid black; padding: 2px; display: inline-block;">Ignition switch "ON"</div> └ For 5 seconds after turning ignition switch "ON" | 0.7 - 0.9V |
| | | <div style="border: 1px solid black; padding: 2px; display: inline-block;">Engine is running.</div> | |
| | | <div style="border: 1px solid black; padding: 2px; display: inline-block;">Ignition switch "ON"</div> └ In 5 seconds after turning ignition switch "ON" | BATTERY VOLTAGE (11 - 14V) |
| 23 | Detonation sensor | <div style="border: 1px solid black; padding: 2px; display: inline-block;">Engine is running.</div> └ Idle speed | 3 - 4V |

TROUBLE DIAGNOSES

Electrical Components Inspection

MEASUREMENT VOLTAGE OR RESISTANCE OF E.C.U.

1. Disconnect battery ground cable.
2. Remove dash side panel from vehicle.
3. Disconnect connector cover from E.C.U.
4. Connect battery ground cable.
5. Measure the voltage at each terminal by following "E.C.U. inspection table".

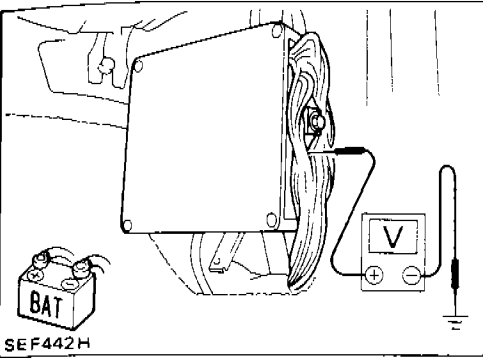
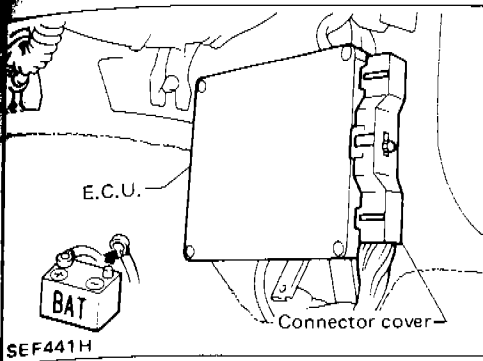

CAUTION:

- a. Perform all voltage measurements with the connectors connected.
- b. Perform all resistance measurements with the connectors disconnected.
- c. Make sure that there are not any bends or breaks on E.C.U. pin terminal before measurements.
- d. Do not touch tester probes between terminals ④9 and ⑤0, ⑤9 and ⑥0.

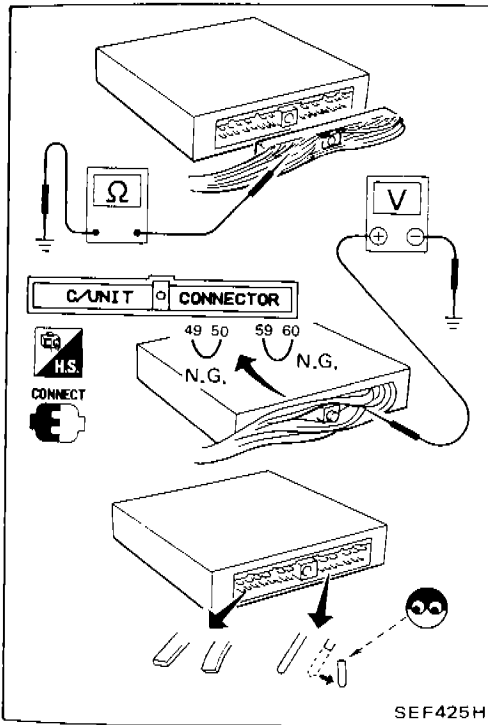

TROUBLE DIAGNOSES

Diagnostic Procedure 18

ACCELERATION CUT CONTROL (Not self-diagnostic item)

- (L) : L. H. drive model
- (R) : R. H. drive model
- (E) : For Europe
- (G) : Except for Europe

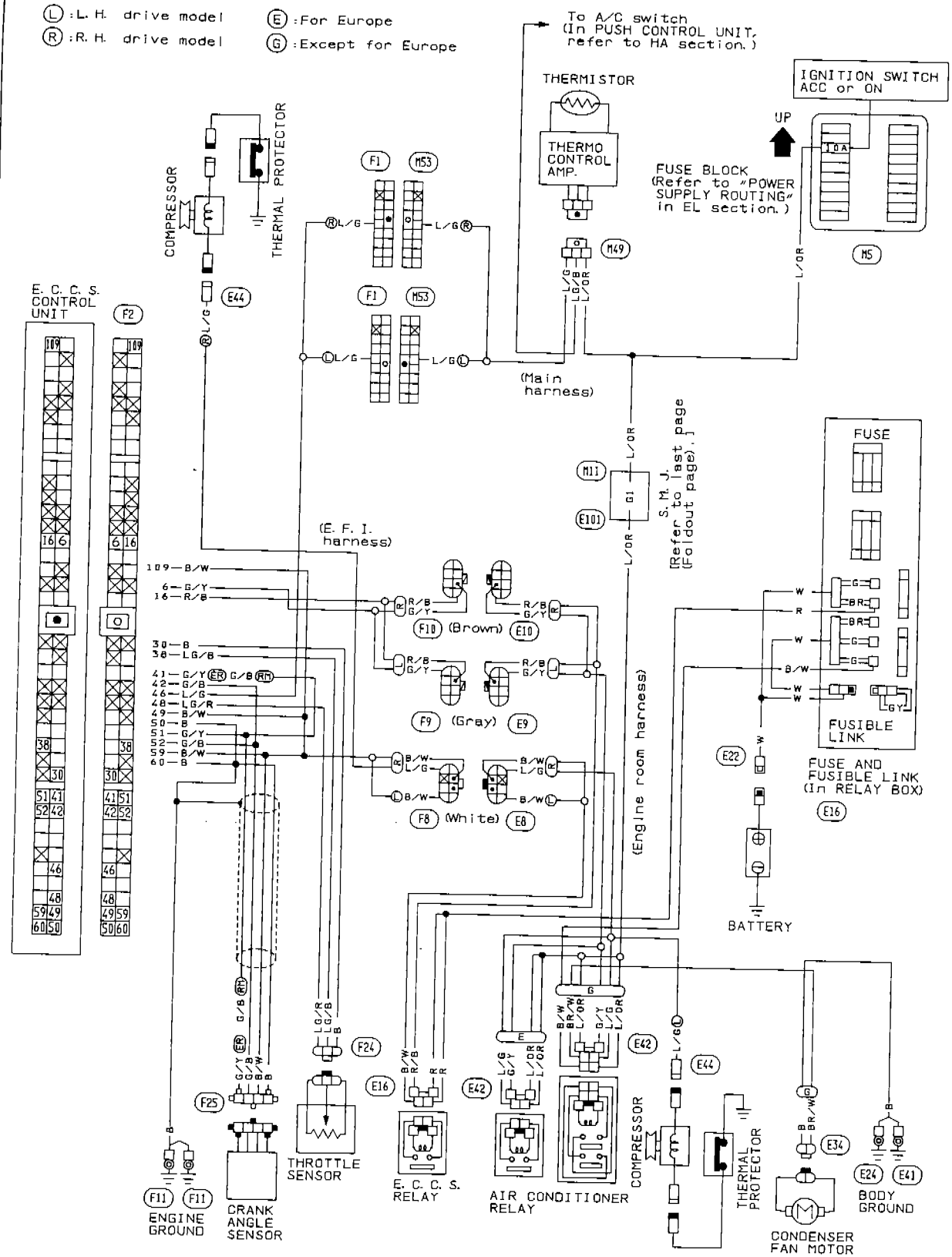

For inspection of this system, refer to HA section.

TROUBLE DIAGNOSES

Diagnostic Procedure 17 (Cont'd)

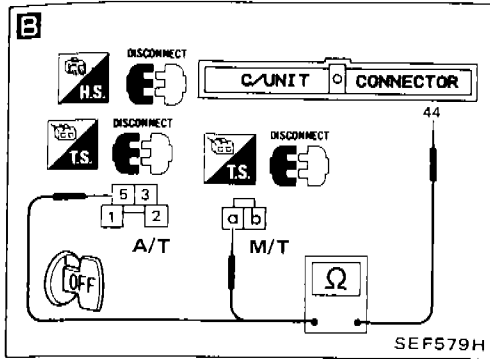
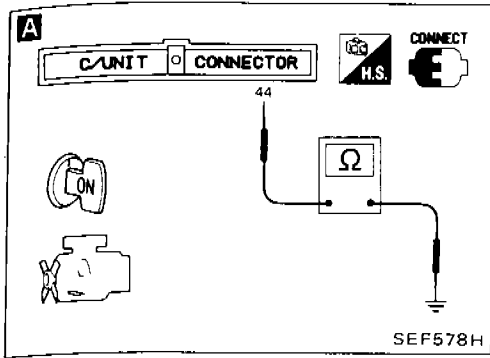

INSPECTION START

A

CHECK INPUT SIGNAL.

- 1) Turn ignition switch "ON".
- 2) Check continuity between terminal ④ and ground.

M/T model

| Shift lever position | Continuity |
|----------------------|------------|
| "Neutral" | Yes |
| Except "Neutral" | No |

A/T model

| Shift lever position | Continuity |
|----------------------------|------------|
| "Neutral" or "Park" | Yes |
| Except "Neutral" or "Park" | No |

O.K.

INSPECTION END

N.G.

B

- 1) Turn ignition switch "OFF".

— M/T model —

- 2) Disconnect E.C.U. harness connector and neutral switch harness connector.
- 3) Check resistance between terminals ④ and ①.

— A/T model —

- 2) Disconnect E.C.U. harness connector and inhibitor relay.
- 3) Check resistance between terminals ④ and ⑤.

Resistance:
Approximately 0Ω

N.G.

Repair or replace harness or connectors.

O.K.

CHECK COMPONENT.

M/T model

- Neutral switch

A/T model

- Inhibitor switch and relay

(See page EF & EC-127.)

N.G.

Repair or replace.

O.K.

INSPECTION END

TROUBLE DIAGNOSES

Diagnostic Procedure 17

NEUTRAL AND INHIBITOR SWITCH (Not self-diagnostic item)

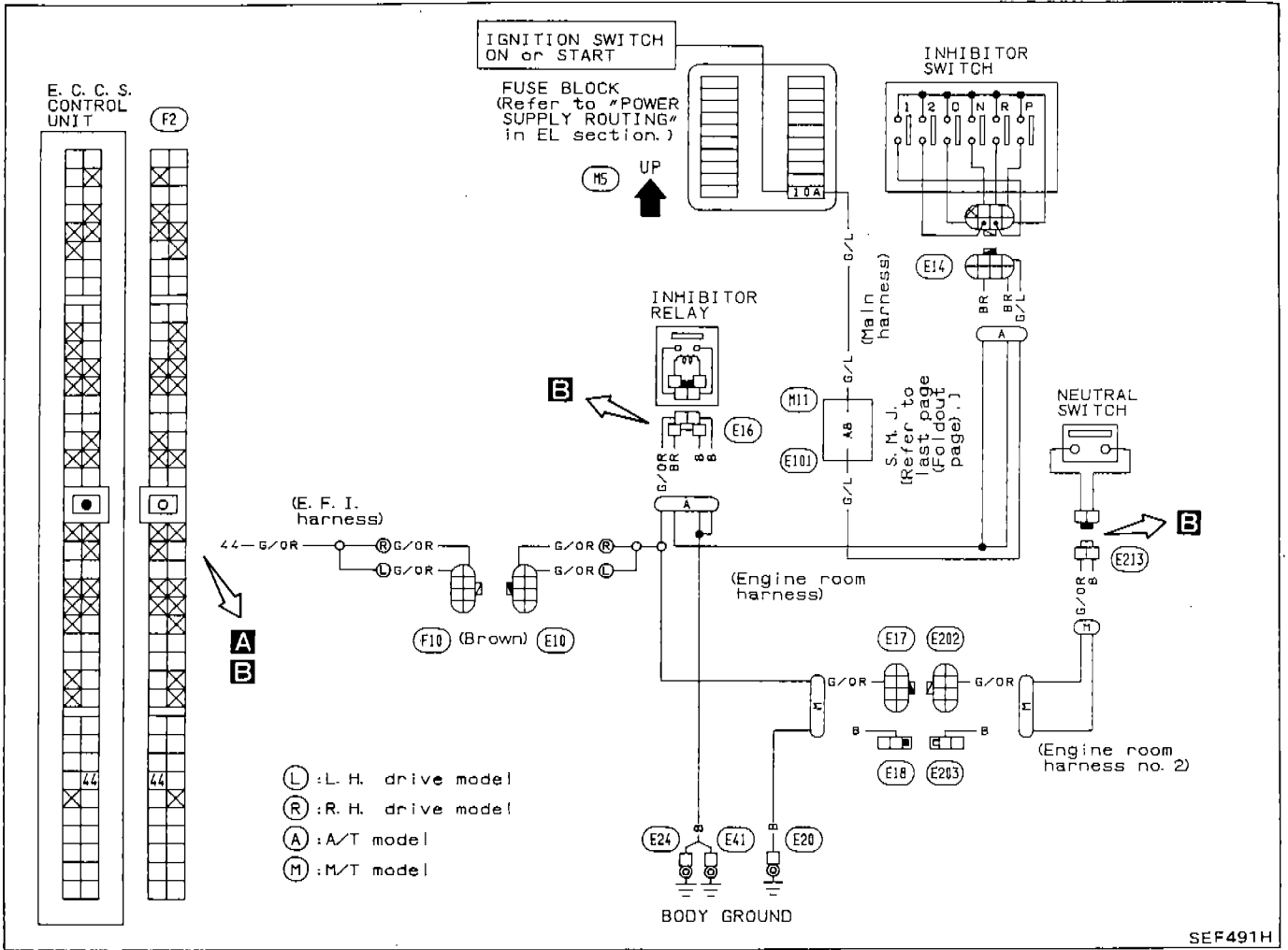

SEF491H

TROUBLE DIAGNOSES

Diagnostic Procedure 16 (Cont'd)

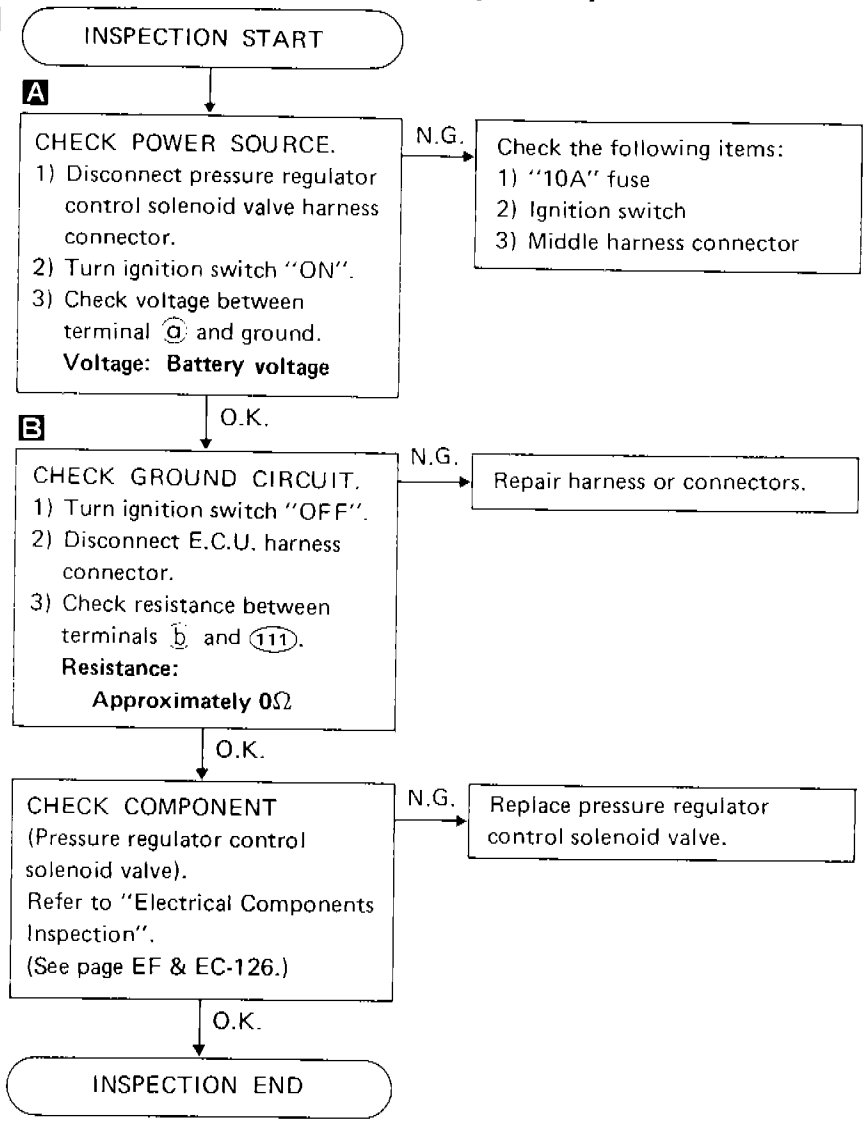
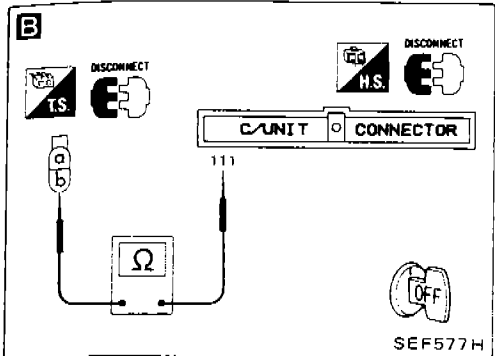
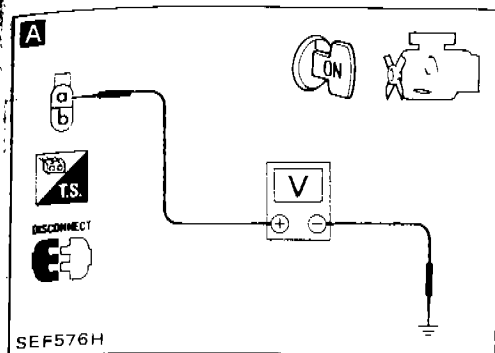

TROUBLE DIAGNOSES

Diagnostic Procedure 16

PRESSURE REGULATOR (P.R.) CONTROL SOLENOID VALVE (Not self-diagnostic item)

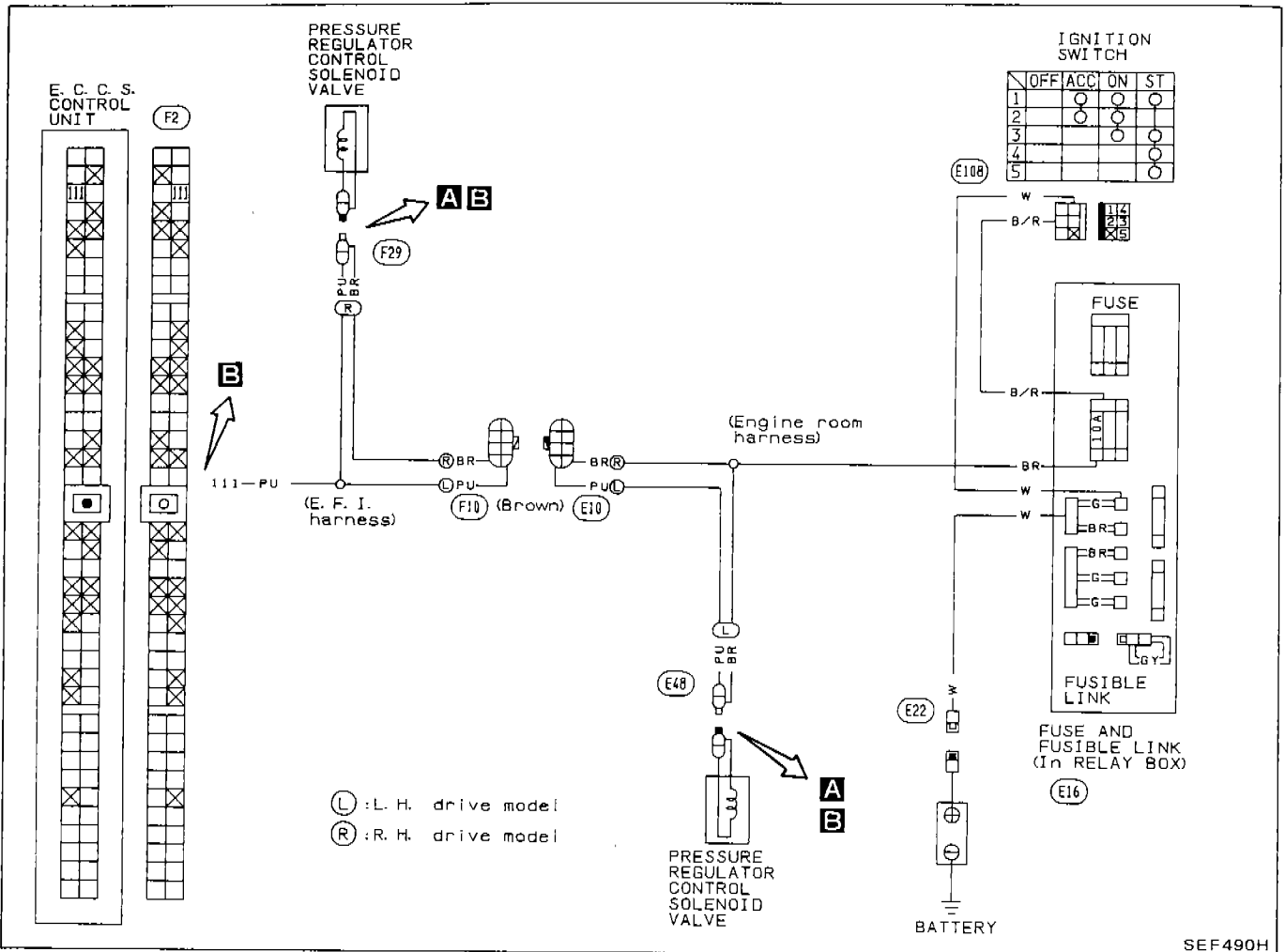

Component location

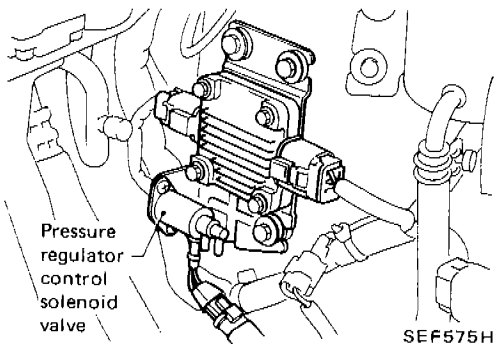

TROUBLE DIAGNOSES

Diagnostic Procedure 15 (Cont'd)

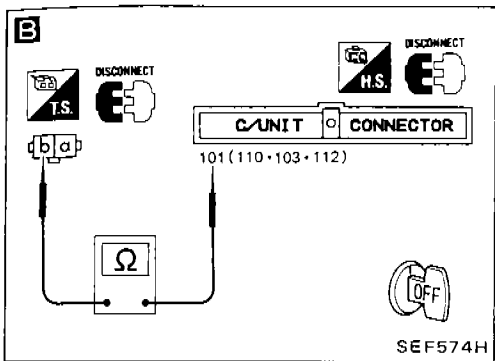
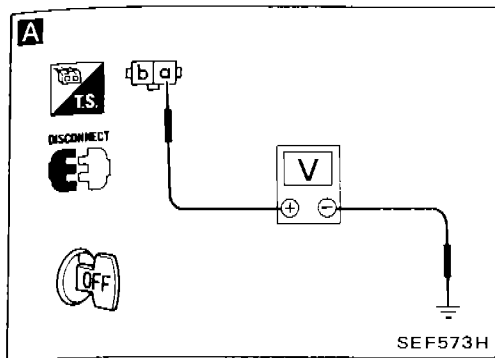

INSPECTION START

A

CHECK POWER SOURCE.

- 1) Disconnect injector harness connector.
- 2) Check voltage between terminal **a** and ground.

Voltage: Battery voltage

N.G.

Check the following items:

- 1) Dropping resistor (See page EF & EC-128.)
- 2) "BR" fusible link
- 3) Middle harness connector

O.K.

B

CHECK GROUND CIRCUIT.

- 1) Disconnect E.C.U. harness connector.
- 2) Check resistance between terminals **b** and **101** (No. 1 cylinder), **110** (No. 2 cylinder), **103** (No. 3 cylinder), **112** (No. 4 cylinder).

Resistance:

Approximately 0Ω

N.G.

Repair harness or connectors.

O.K.

CHECK COMPONENT (Injector).

Refer to "Electrical Components Inspection". (See page EF & EC-125.)

N.G.

Replace injector.

O.K.

INSPECTION END

TROUBLE DIAGNOSES

Diagnostic Procedure 15

INJECTOR (Not self-diagnostic item)

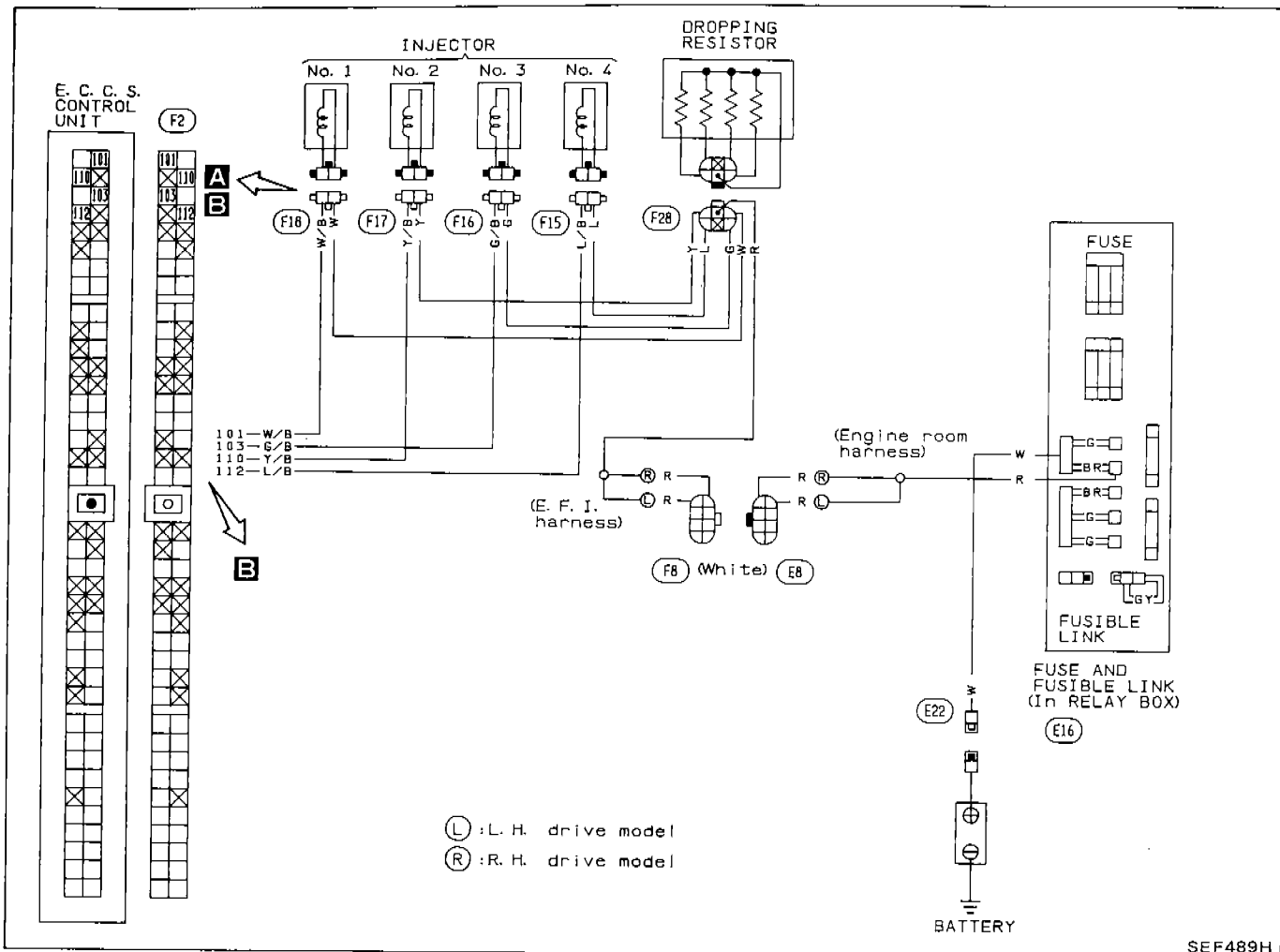

Component location

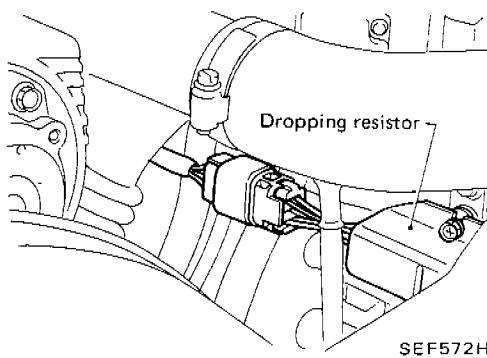
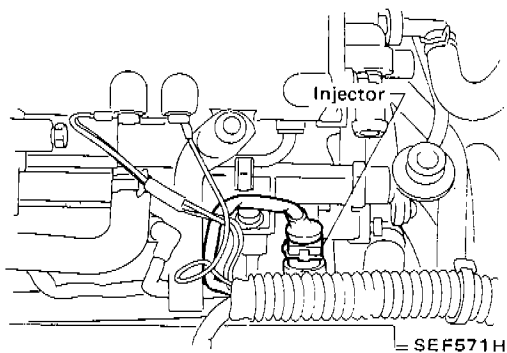

TROUBLE DIAGNOSES

Diagnostic Procedure 14 (Cont'd)

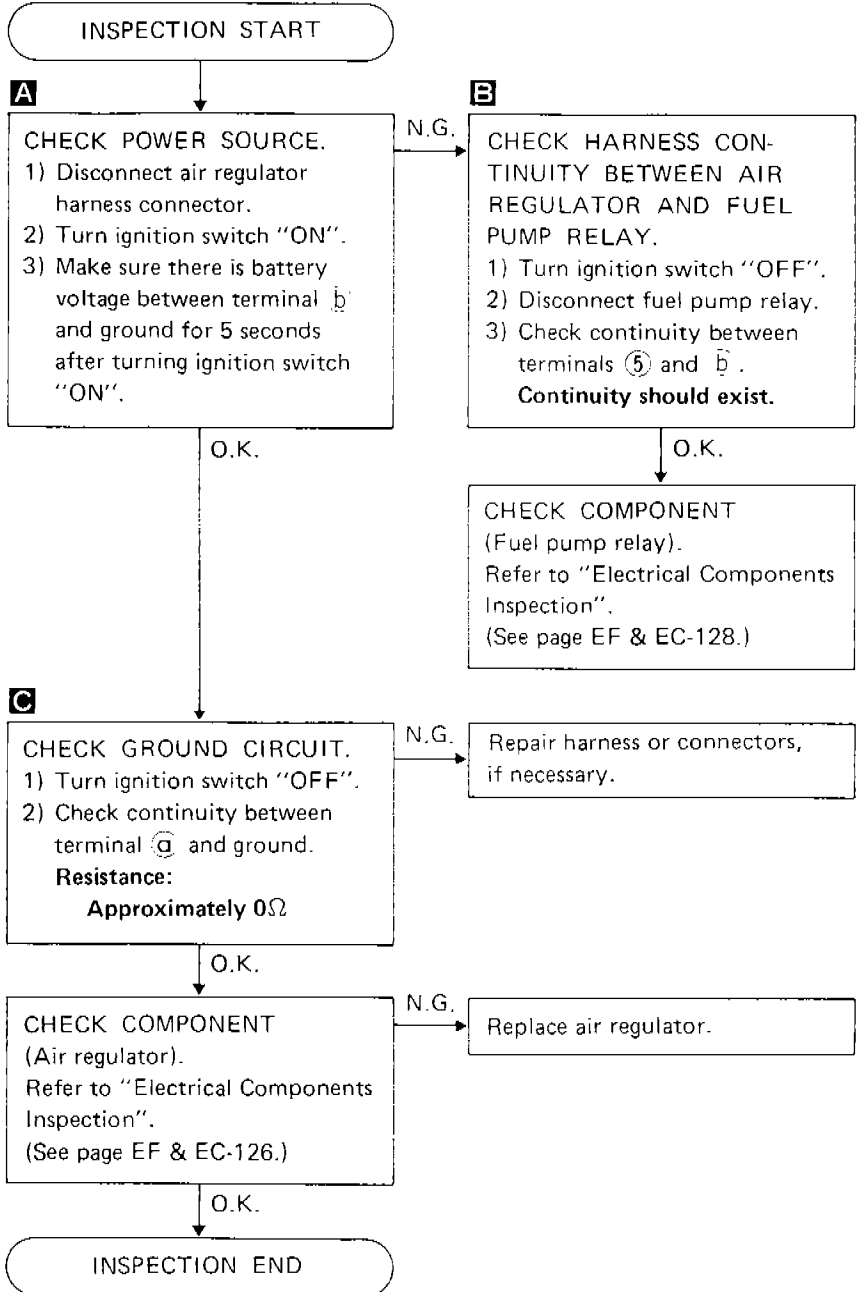
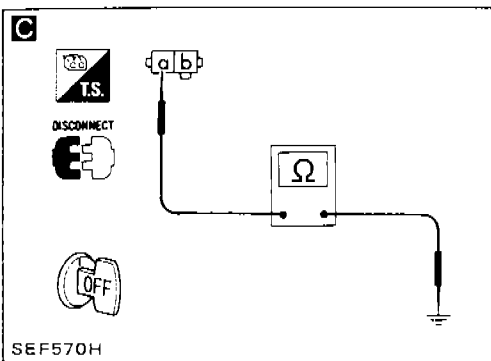
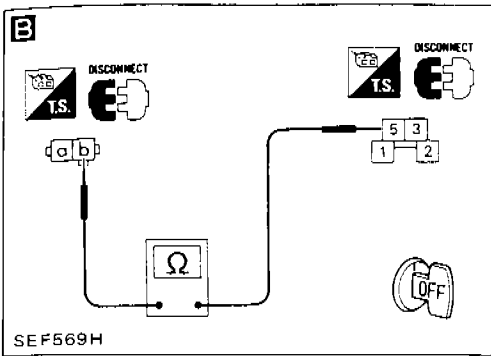
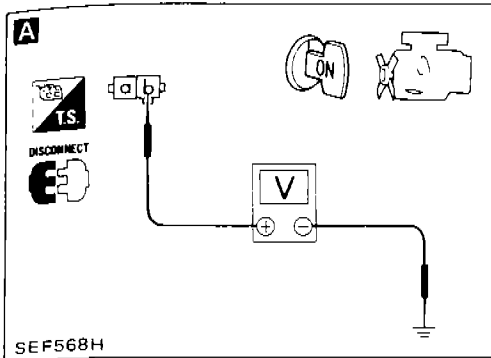

TROUBLE DIAGNOSES

Diagnostic Procedure 14

AIR REGULATOR (Not self-diagnostic item)

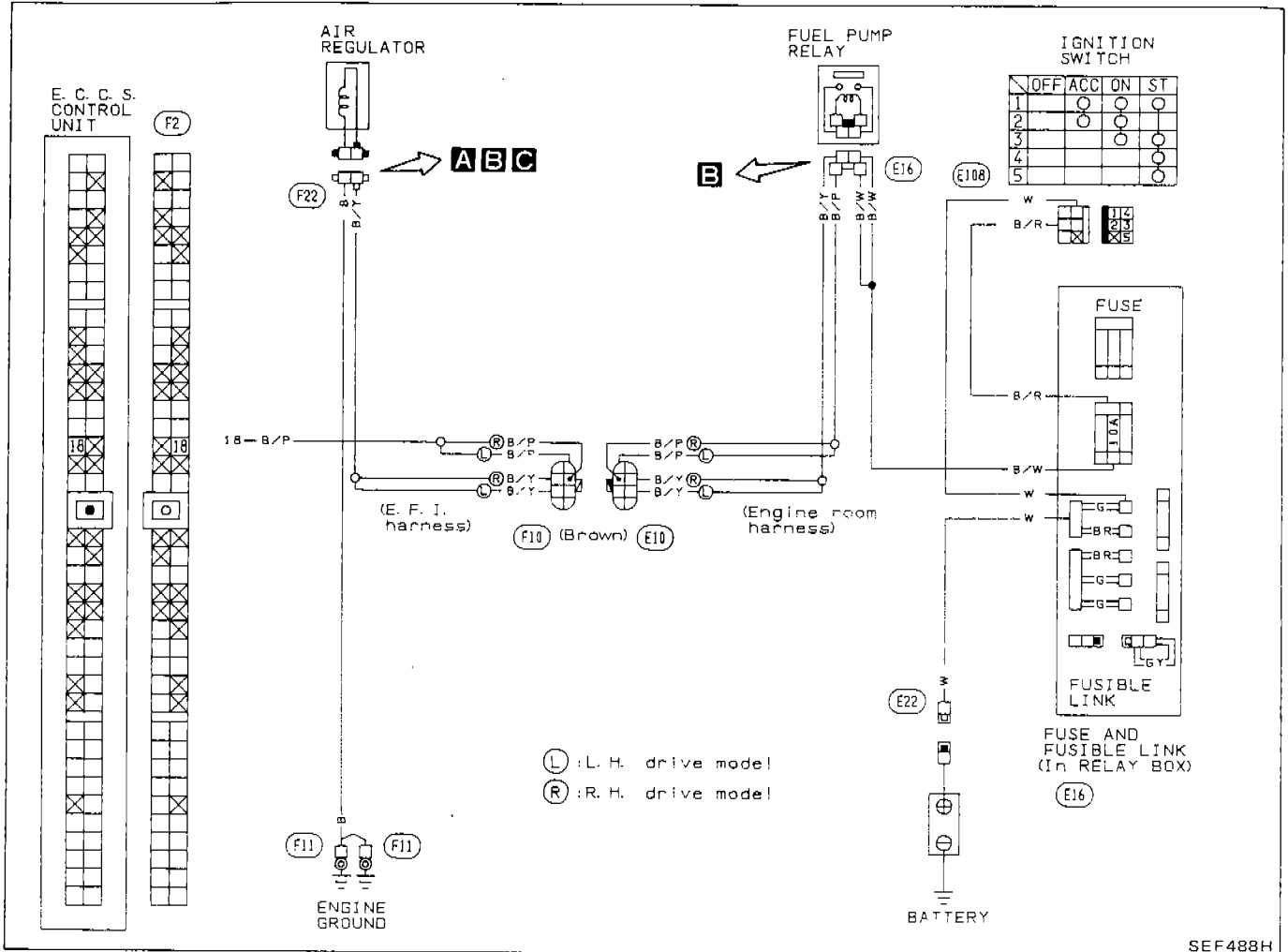

Component location

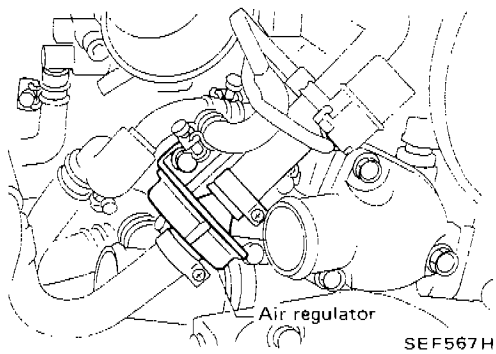

TROUBLE DIAGNOSES

Diagnostic Procedure 13 (Cont'd)

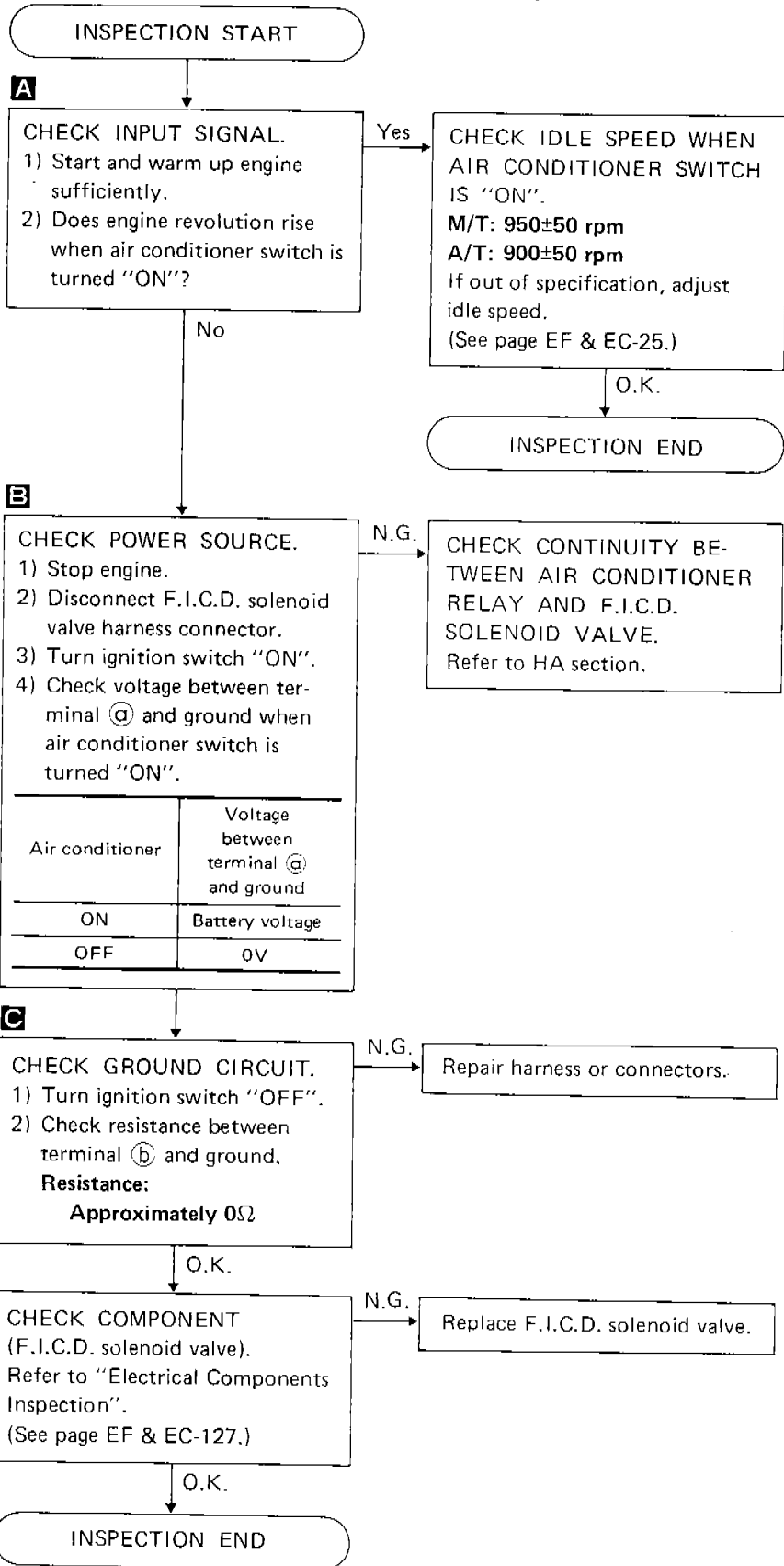
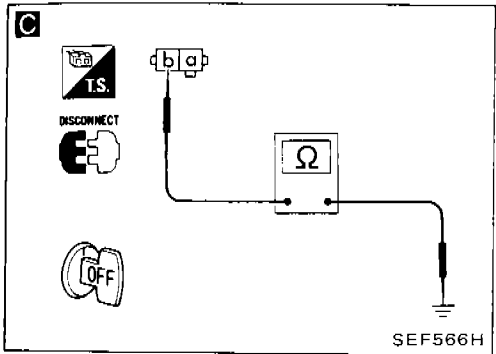
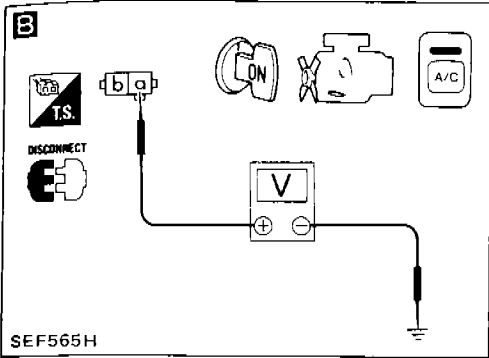
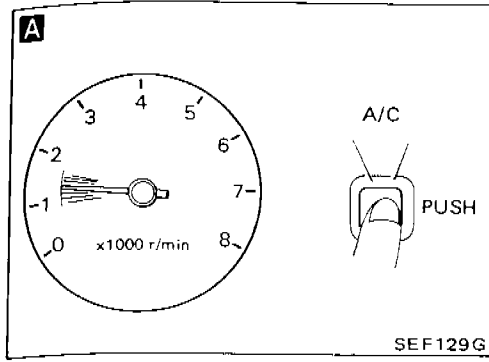

TROUBLE DIAGNOSES

Diagnostic Procedure 13

I.A.A. CONTROL (F.I.C.D. CONTROL) (Not self-diagnostic item)

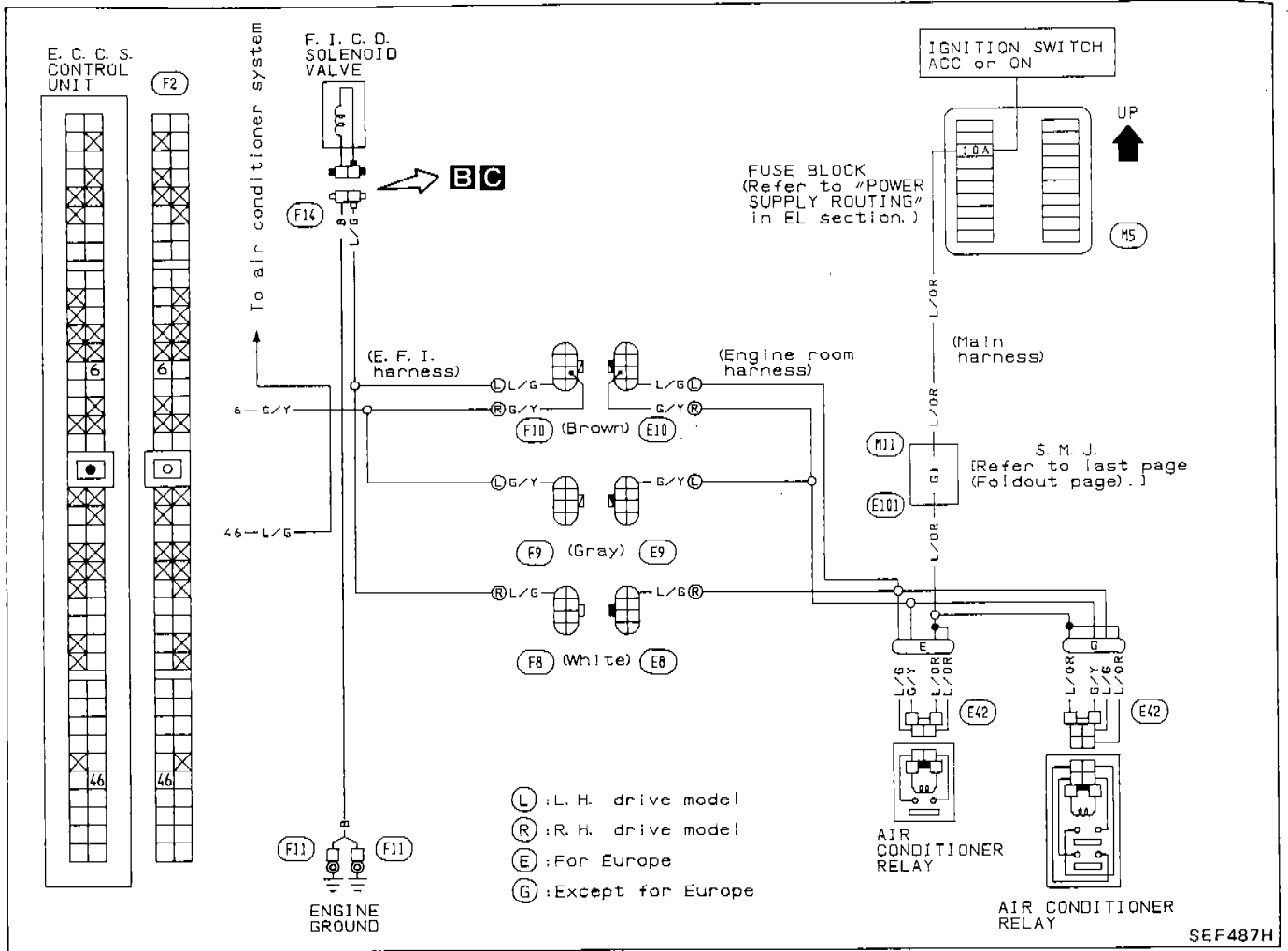

Component location

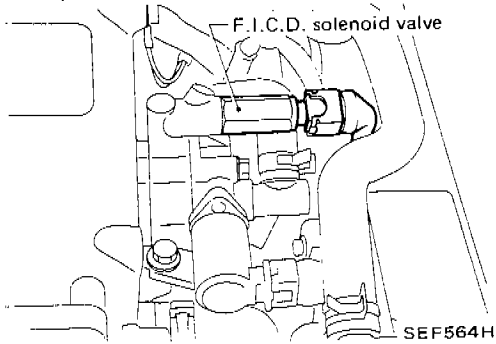

TROUBLE DIAGNOSES

Diagnostic Procedure 12 (Cont'd)

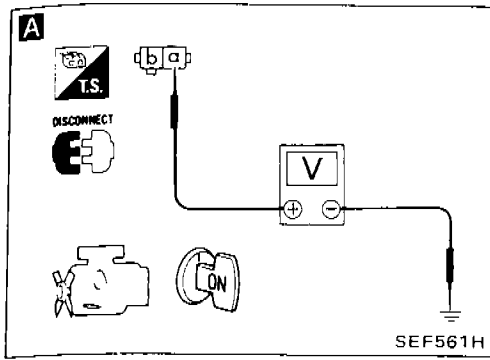

INSPECTION START

CHECK COMPONENT

(A.A.C. valve).

Refer to "Electrical Components Inspection".

(See page EF & EC-125.)

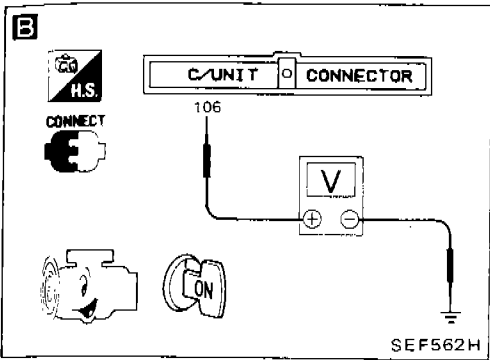

CHECK POWER SOURCE.

- 1) Disconnect A.A.C. valve harness connector.
- 2) Turn ignition switch "ON".
- 3) Check voltage between terminal ⑩ and ground.

Voltage: Battery voltage

If N.G., repair harness or connectors.

N.G.

Check the following items:

- 1) "10A" fuse
- 2) Ignition switch
- 3) Middle harness connector

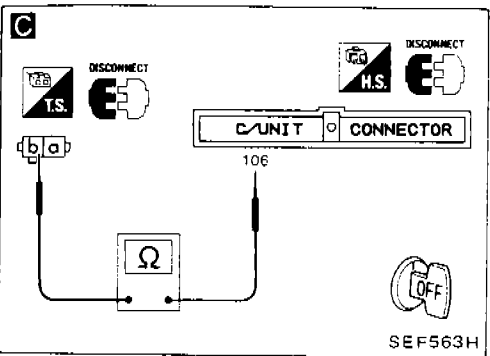

B

CHECK INPUT SIGNAL.

- 1) Reconnect A.A.C. valve harness connector.
- 2) Start engine and warm it up sufficiently.
- 3) Check voltage between E.C.U. terminal ⑩ and ground.

Voltage:

Approximately 6 - 12V

O.K.

C

CHECK CONTINUITY BETWEEN E.C.U. AND A.A.C. VALVE.

- 1) Stop engine.
- 2) Disconnect E.C.U. harness connector.
- 3) Disconnect A.A.C. valve harness connector.
- 4) Check resistance between terminals ⑩ and ⑥.

Resistance:

Approximately 0Ω

INSPECTION END

TROUBLE DIAGNOSES

Diagnostic Procedure 12

AUXILIARY AIR CONTROL (A.A.C.) VALVE (Not self-diagnostic item)

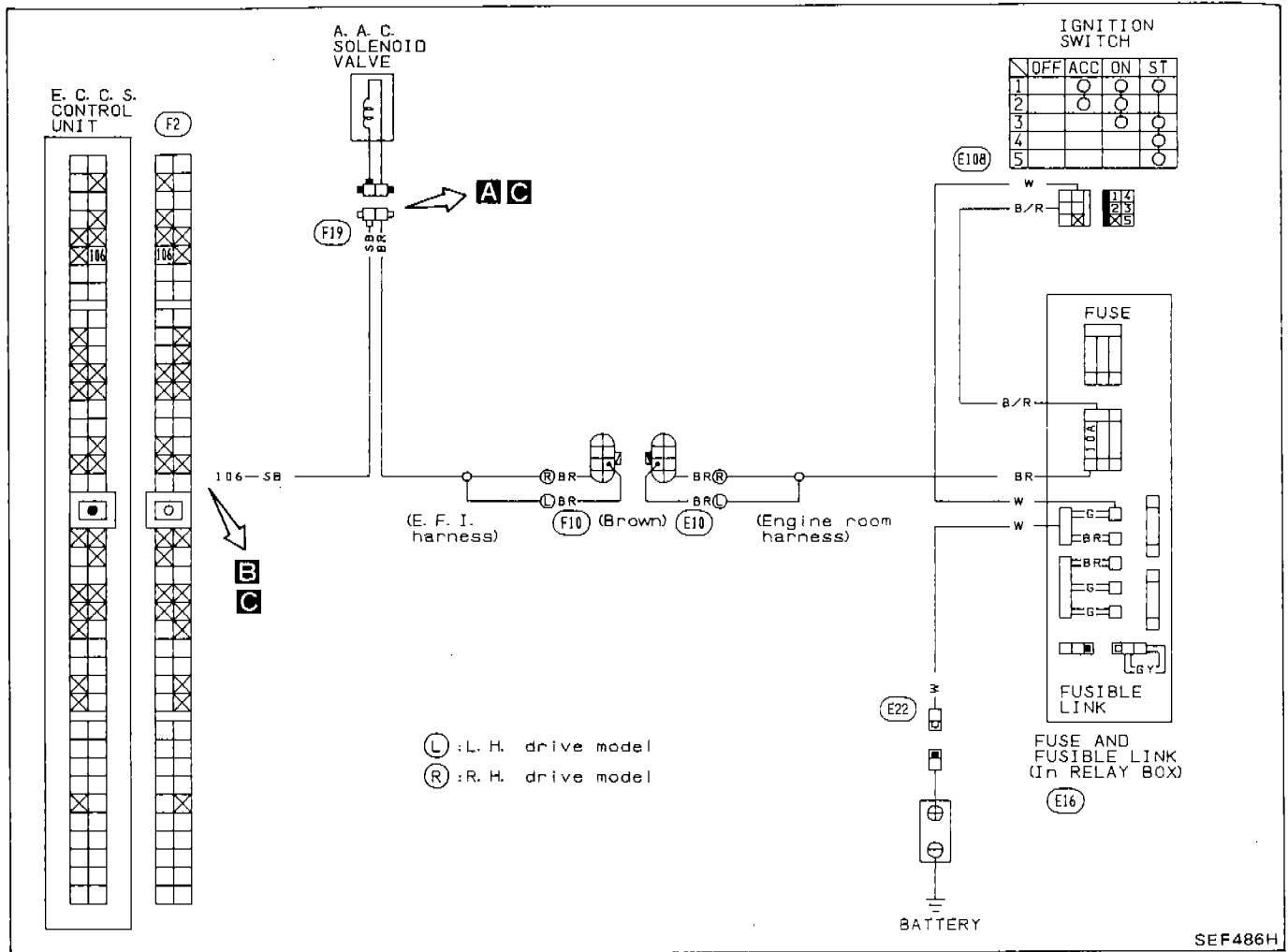

Component location

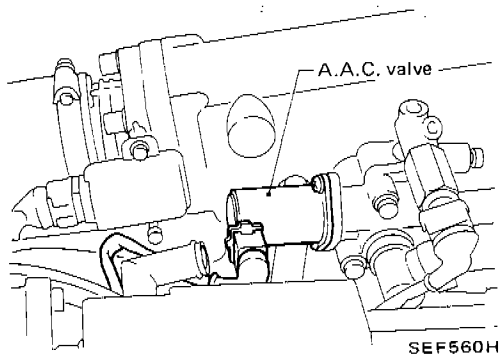

TROUBLE DIAGNOSES

Diagnostic Procedure 11 (Cont'd)

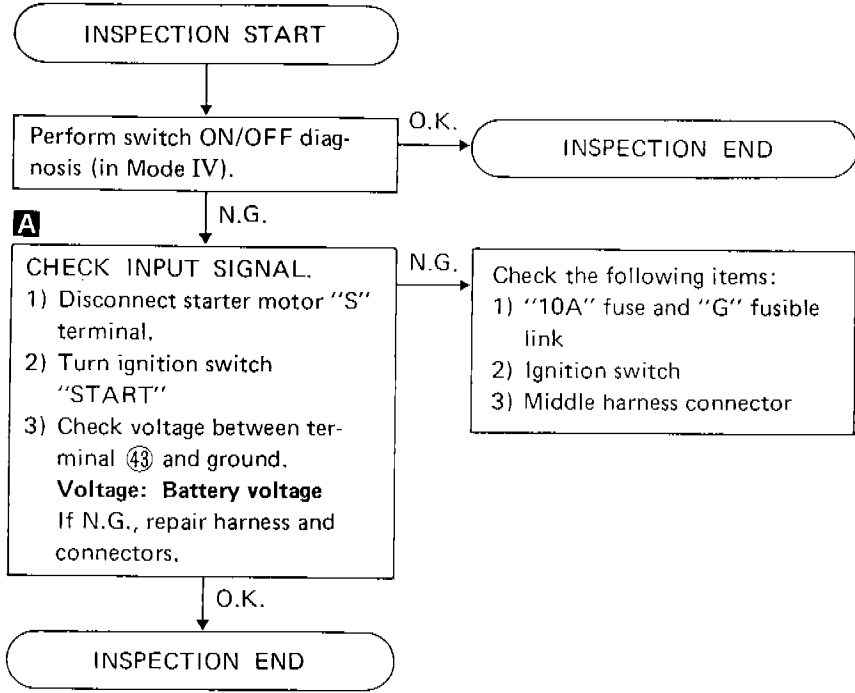
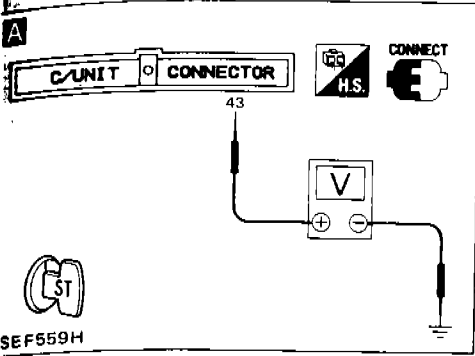

TROUBLE DIAGNOSES

Diagnostic Procedure 11

START SIGNAL (Switch ON/OFF diagnosis)

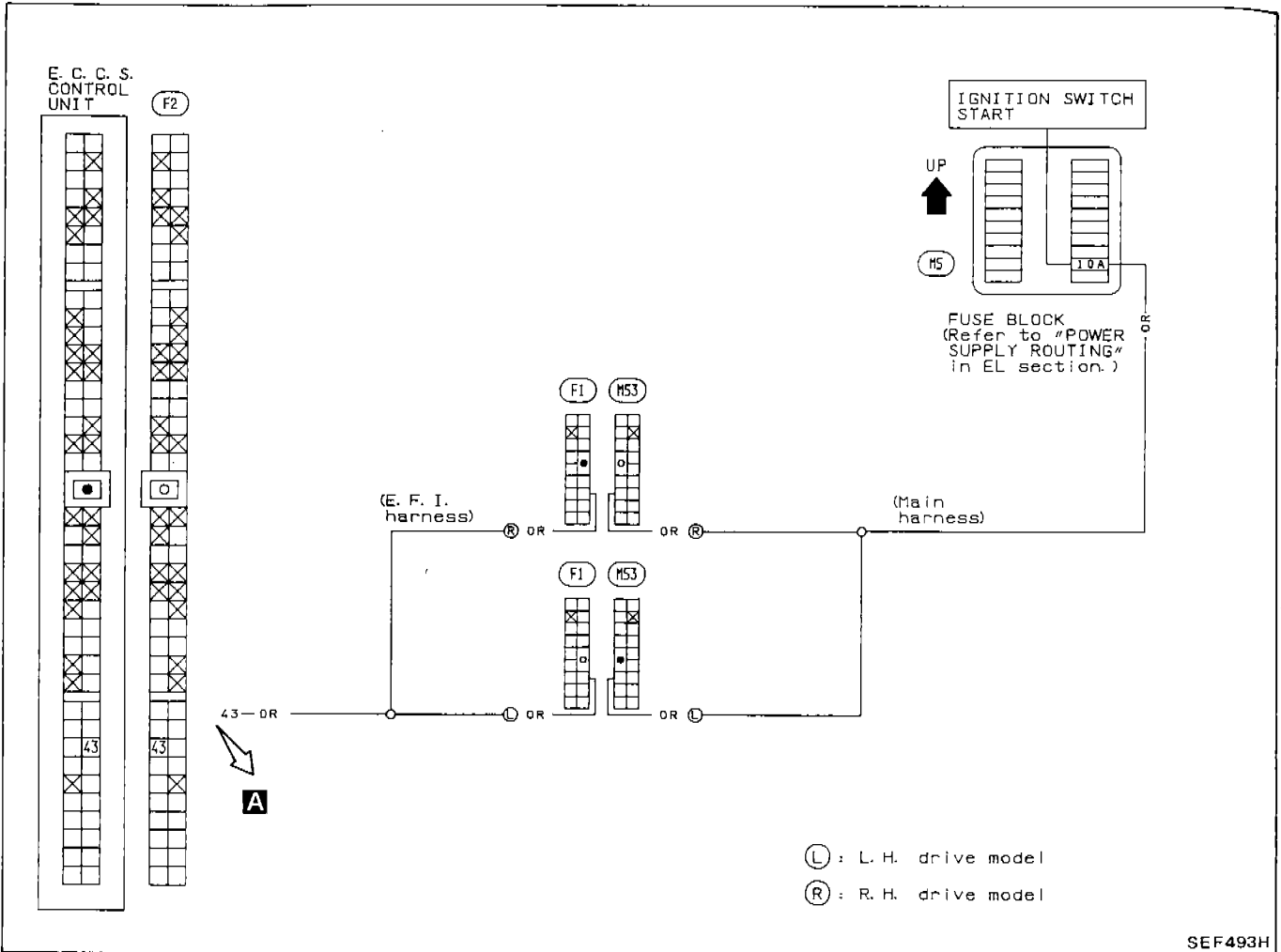

TROUBLE DIAGNOSES

Diagnostic Procedure 10 (Cont'd)

INSPECTION START

A

CHECK POWER SOURCE.

- 1) Disconnect fuel pump harness connector.
- 2) Turn ignition switch "ON".
- 3) Make sure there is battery voltage between terminal (b) and ground for 5 seconds after turning ignition switch "ON".

B

CHECK HARNESS CONTINUITY BETWEEN FUEL PUMP AND FUEL PUMP RELAY.

- 1) Turn ignition switch "OFF".
- 2) Disconnect fuel pump relay.
- 3) Disconnect fuel pump harness connector.
- 4) Check continuity between terminals (5) and (b).

CHECK COMPONENT (Fuel pump relay).
Refer to "Electrical Components Inspection".
(See page EF & EC-128.)

C

CHECK GROUND CIRCUIT.

- 1) Turn ignition switch "OFF".
- 2) Check continuity between terminal (a) and ground.

Continuity:
Approximately 0Ω

Repair harness or connectors, if necessary.

CHECK COMPONENT (Fuel pump).
Refer to "Electrical Components Inspection".
(See page EF & EC-126.)

Replace fuel pump.

INSPECTION END

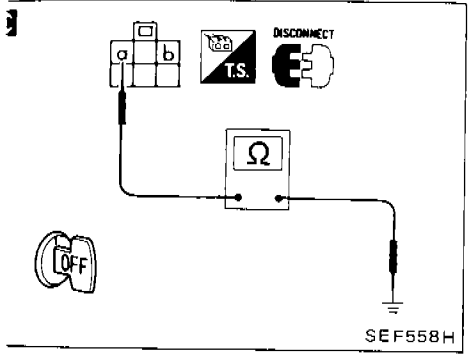
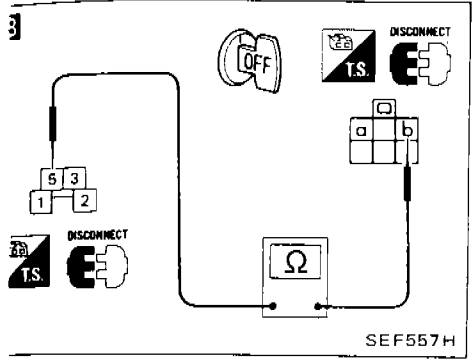
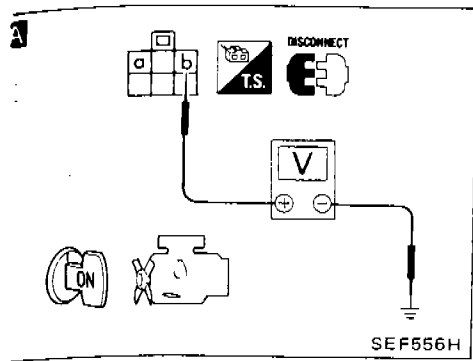

TROUBLE DIAGNOSES

Diagnostic Procedure 10

FUEL PUMP (Not self-diagnostic item)

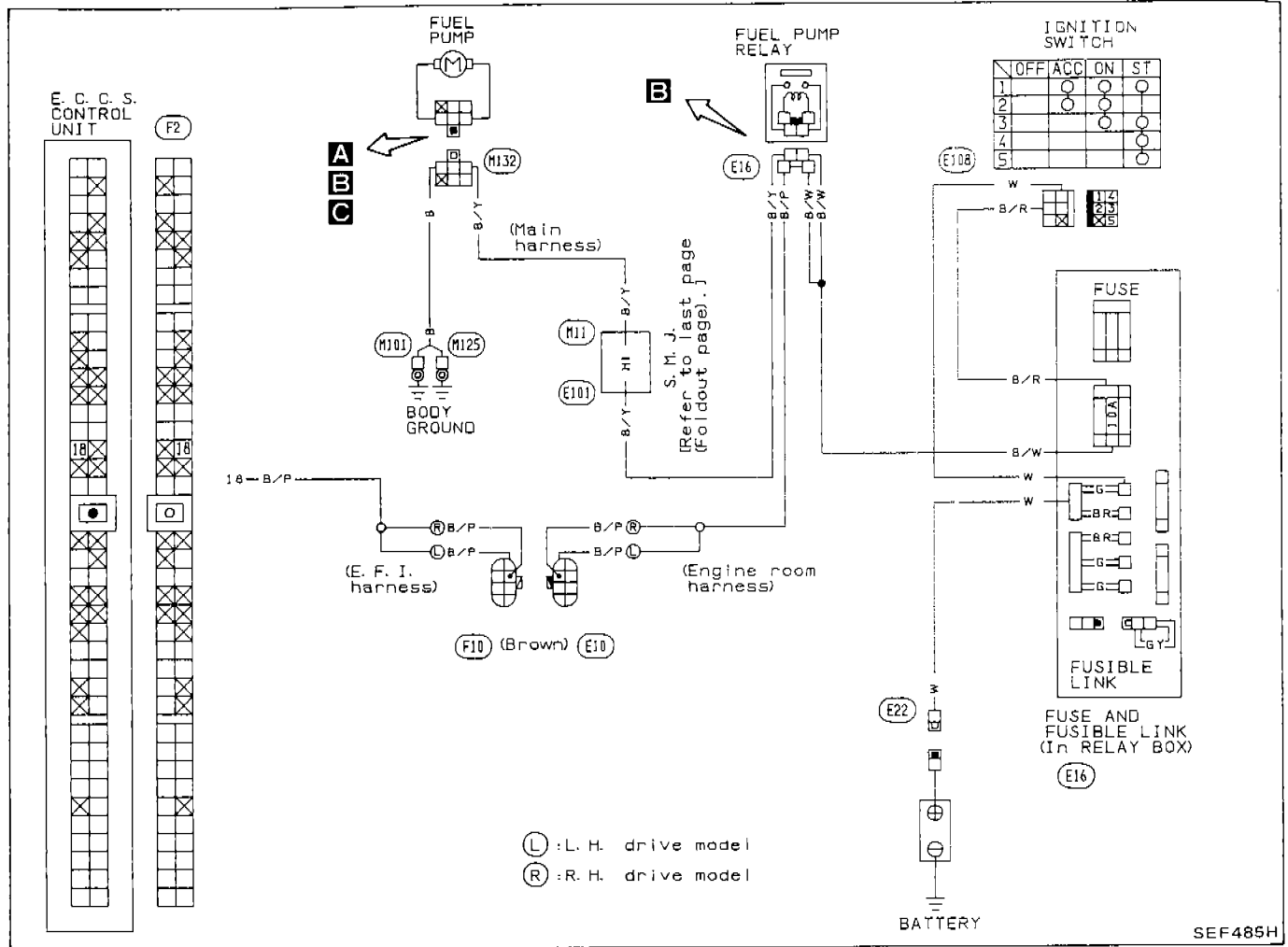

Component location

In the trunk room

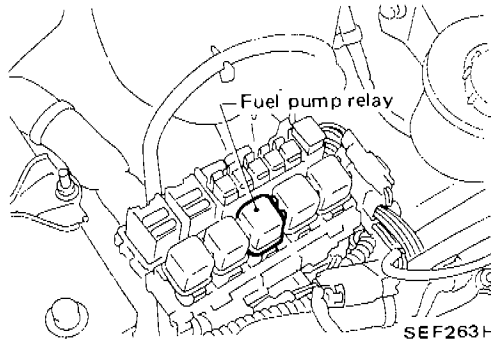
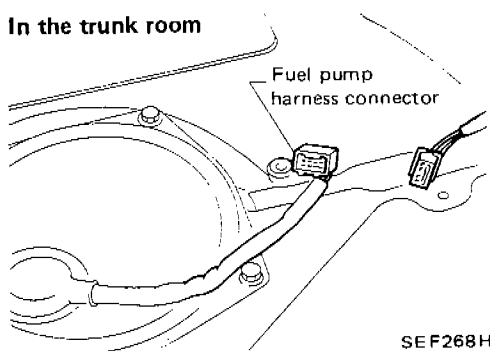

TROUBLE DIAGNOSES

NOTE

EF & EC-101

TROUBLE DIAGNOSES

Diagnostic Procedure 9 (Cont'd)

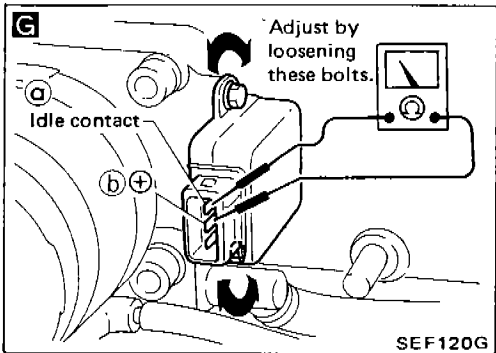
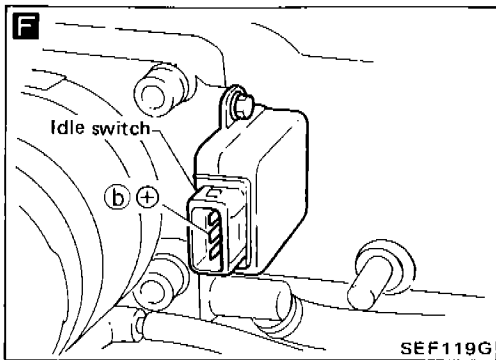

⊕
↓
Disconnect throttle sensor harness connector.

↓
CHECK COMPONENT
(Throttle sensor).
Refer to "Electrical Components Inspection".
(See page EF & EC-124.)

↓
CHECK IDLE SWITCH OFF → ON SPEED.

- 1) Reconnect throttle sensor harness connector.
- F** 2) Disconnect idle switch harness connector.
- 3) Start and warm up engine sufficiently.
- 4) Check idle switch OFF → ON speed with circuit tester, closing throttle valve manually.

Idle switch OFF → ON speed:

**M/T Idle speed +
250±150 rpm**

**A/T Engine speed (Idle
speed in "N"
position) +
250±150 rpm**

- G** 5) If N.G., loosen throttle sensor installing screws, then set idle switch OFF → ON speed to the specified value by turning throttle sensor body.
(Connect circuit tester with terminals **a** and **b** on idle switch side and find out OFF → ON point.)
- 6) Tighten throttle sensor installing screws after setting.

TROUBLE DIAGNOSES

Diagnostic Procedure 9 (Cont'd)

INSPECTION START

Perform self-diagnosis (Mode III).
Is code No. 43 indicated?

N.G.

INSPECTION END

A

CHECK POWER SOURCE.

- 1) Disconnect throttle sensor harness connector.
- 2) Turn ignition switch "ON".
- 3) Check voltage between terminal (f) and ground.

Voltage:

Approximately 5.0V

N.G.

Check the following items.

- B**
- 1) Harness continuity between throttle sensor harness connector and E.C.U.
 - a. Turn ignition switch "OFF".
 - b. Disconnect E.C.U. harness connector.
 - c. Check resistance between (f) and (48).

Resistance:

Approximately 0Ω

- 2) Middle harness connector
- 3) E.C.C.S. relay
(Refer to page EF & EC-128.)

O.K.

C

CHECK GROUND CIRCUIT.

- 1) Turn ignition switch "OFF" and disconnect E.C.U. harness connector.
- 2) Disconnect throttle sensor harness connector.
- 3) Check resistance between terminal (d) and E.C.U. terminal (30).

Resistance:

Approximately 0Ω

N.G.

- 1) Check harness continuity between throttle sensor and ground.
- 2) E.C.U. ground circuit.

O.K.

D

CHECK THROTTLE SENSOR CIRCUIT.

Check resistance between terminal (e) and E.C.U. terminal (38).

Resistance:

Approximately 0Ω

N.G.

Repair or replace harness.

O.K.

E

CHECK INPUT SIGNAL.

- 1) Reconnect E.C.U. harness connector and throttle sensor harness connector.
- 2) Turn ignition switch "ON".
- 3) Make sure that voltage between terminal (38) and ground changes when accelerator pedal is depressed.

Voltage:

Approximately 0.5 - 4.0V

O.K.

INSPECTION END

N.G.

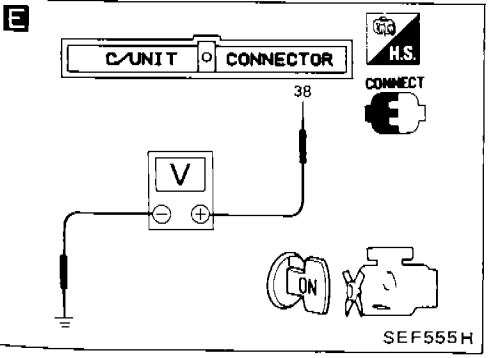
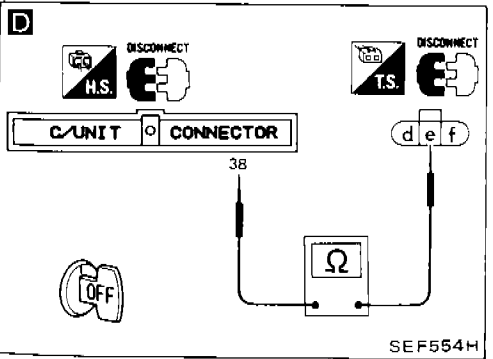
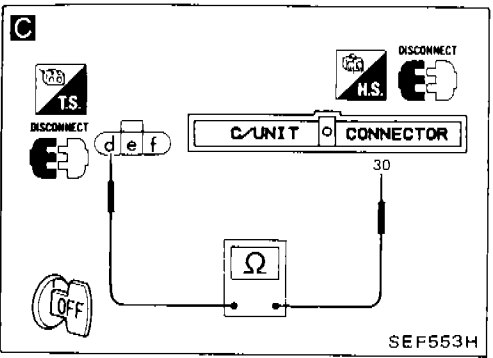
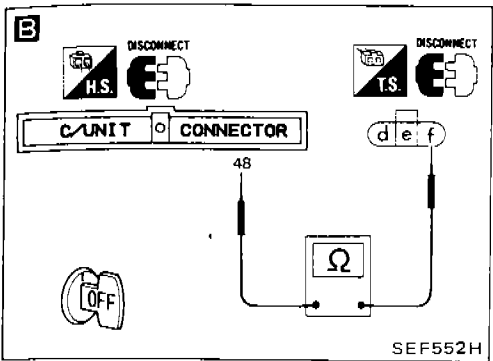
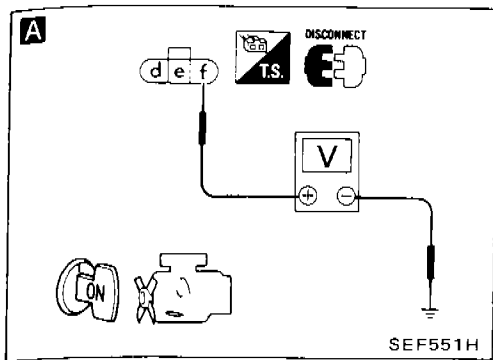

TROUBLE DIAGNOSES

Diagnostic Procedure 9

THROTTLE SENSOR (Code No. 43)

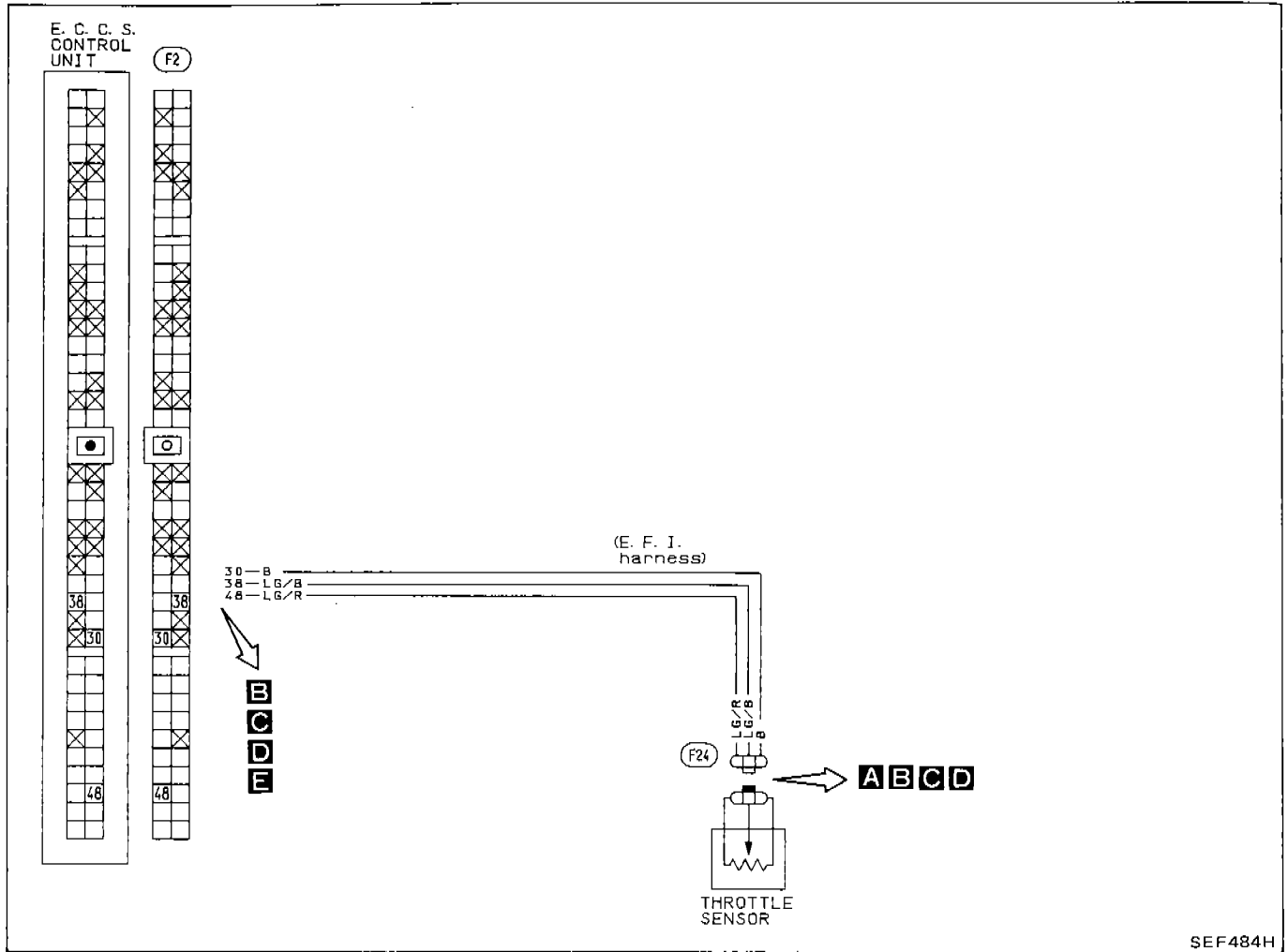

Component location

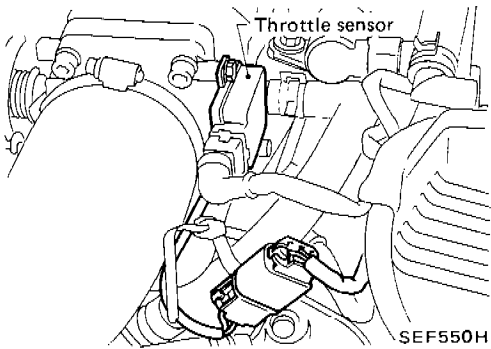

TROUBLE DIAGNOSES

Diagnostic Procedure 8 (Cont'd)

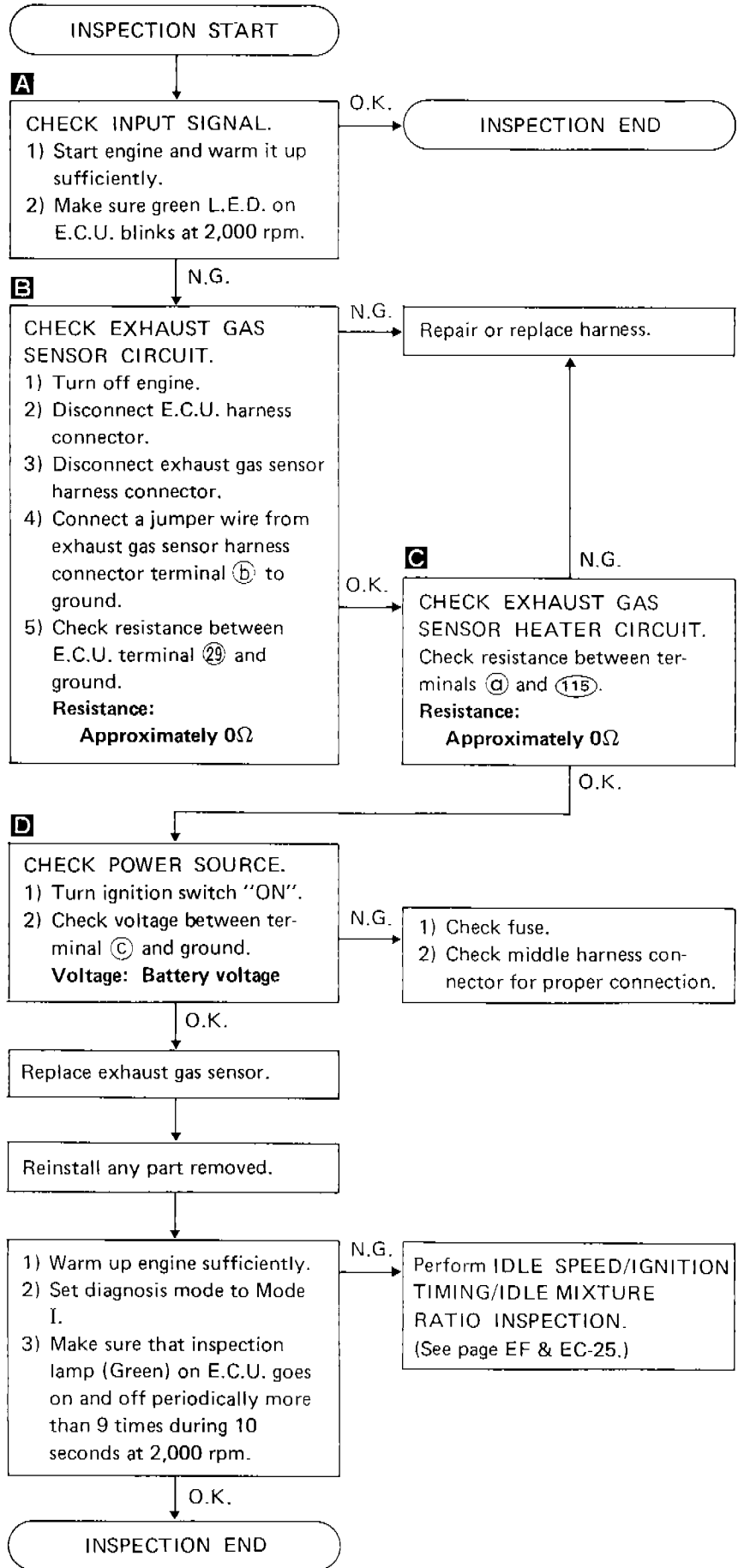
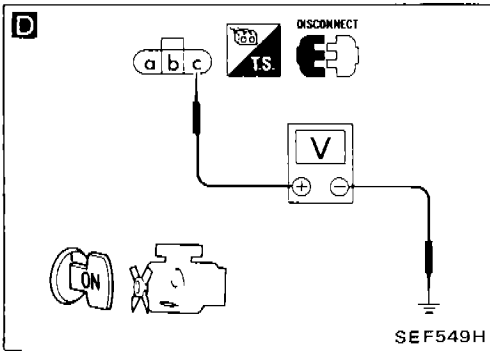
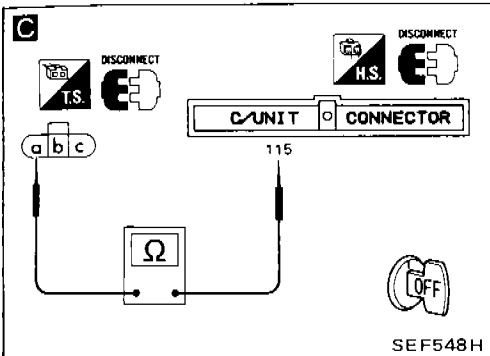
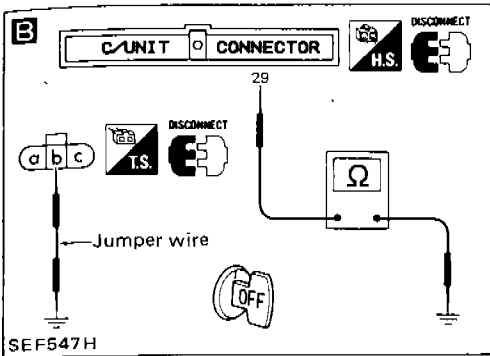
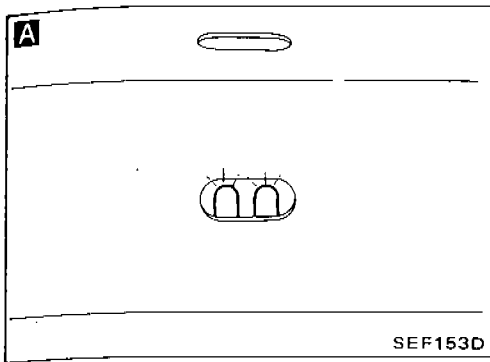

TROUBLE DIAGNOSES

Diagnostic Procedure 8

EXHAUST GAS SENSOR (Not self-diagnostic item)

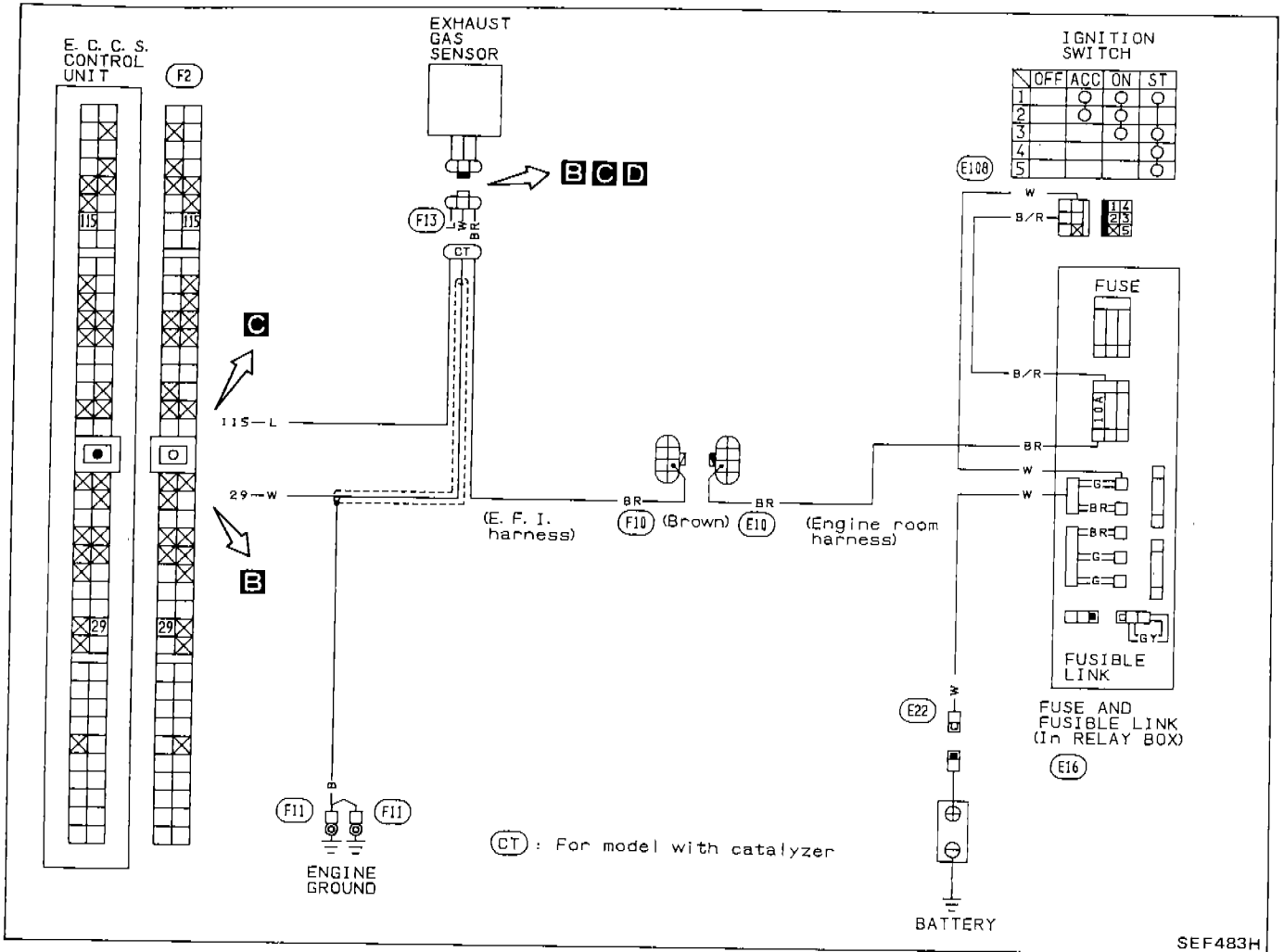

Component location

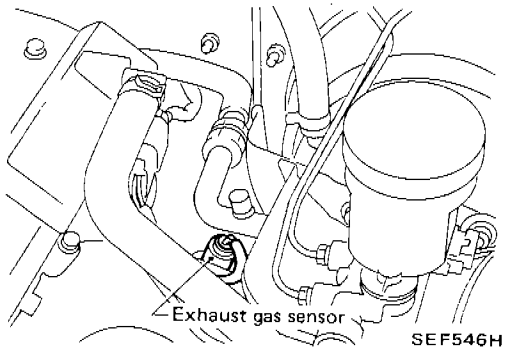

TROUBLE DIAGNOSES

Diagnostic Procedure 7 (Cont'd)

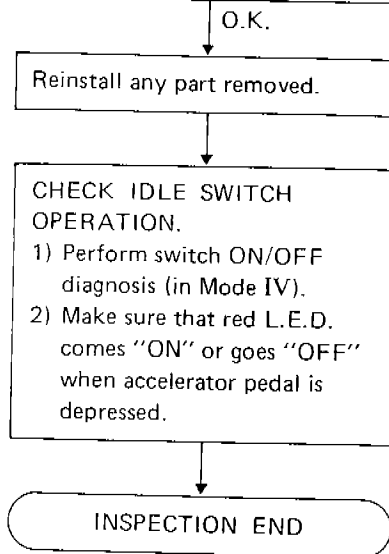
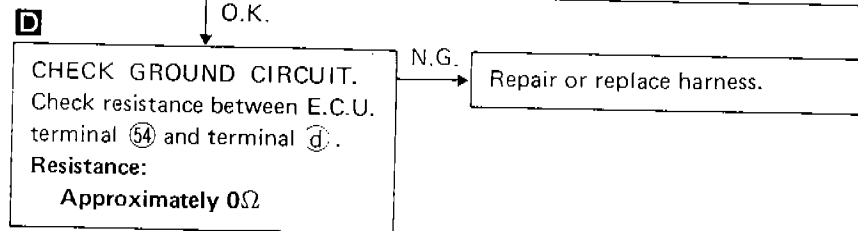
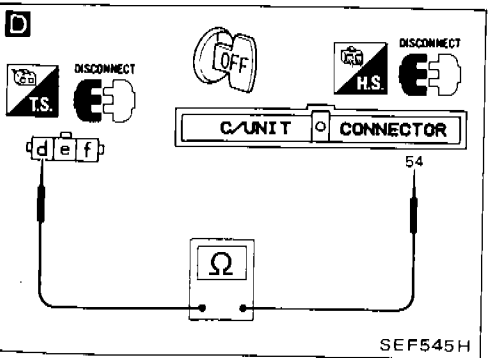
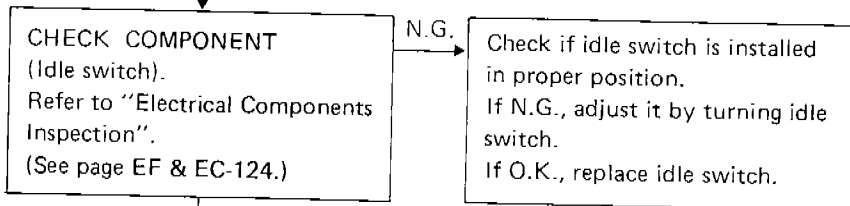
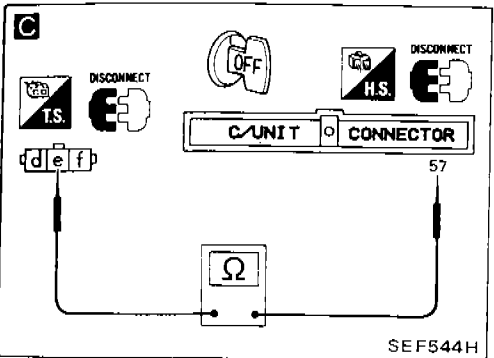
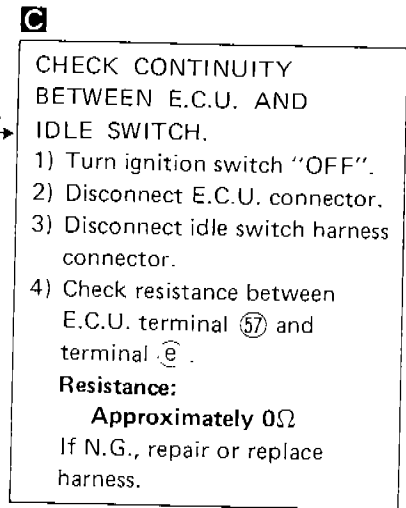
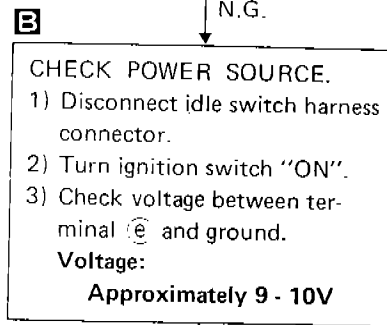
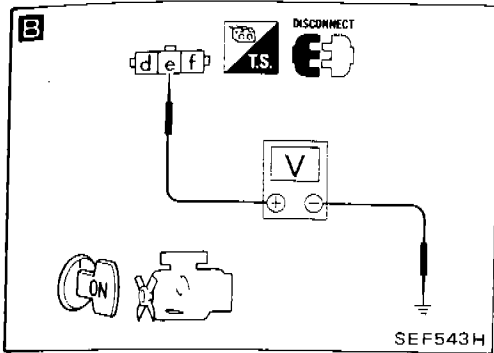
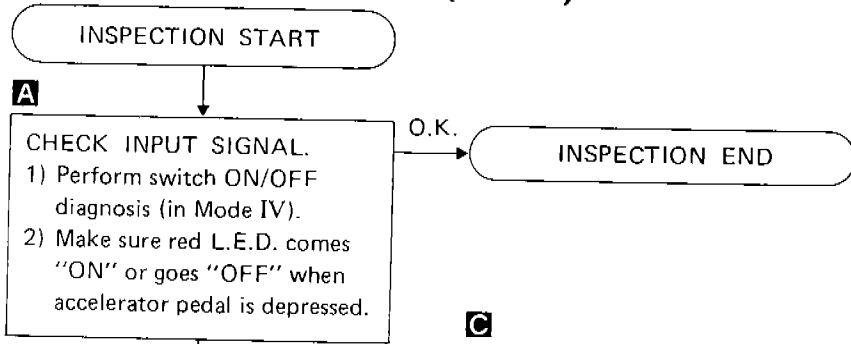
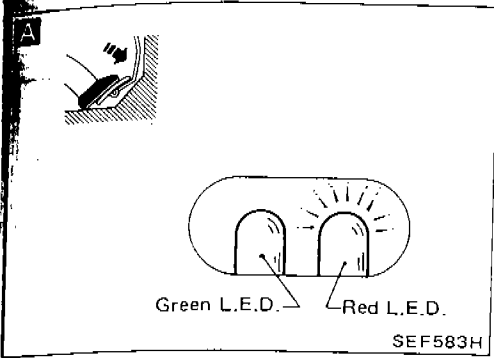

TROUBLE DIAGNOSES

Diagnostic Procedure 7

IDLE SWITCH (Switch ON/OFF diagnosis)

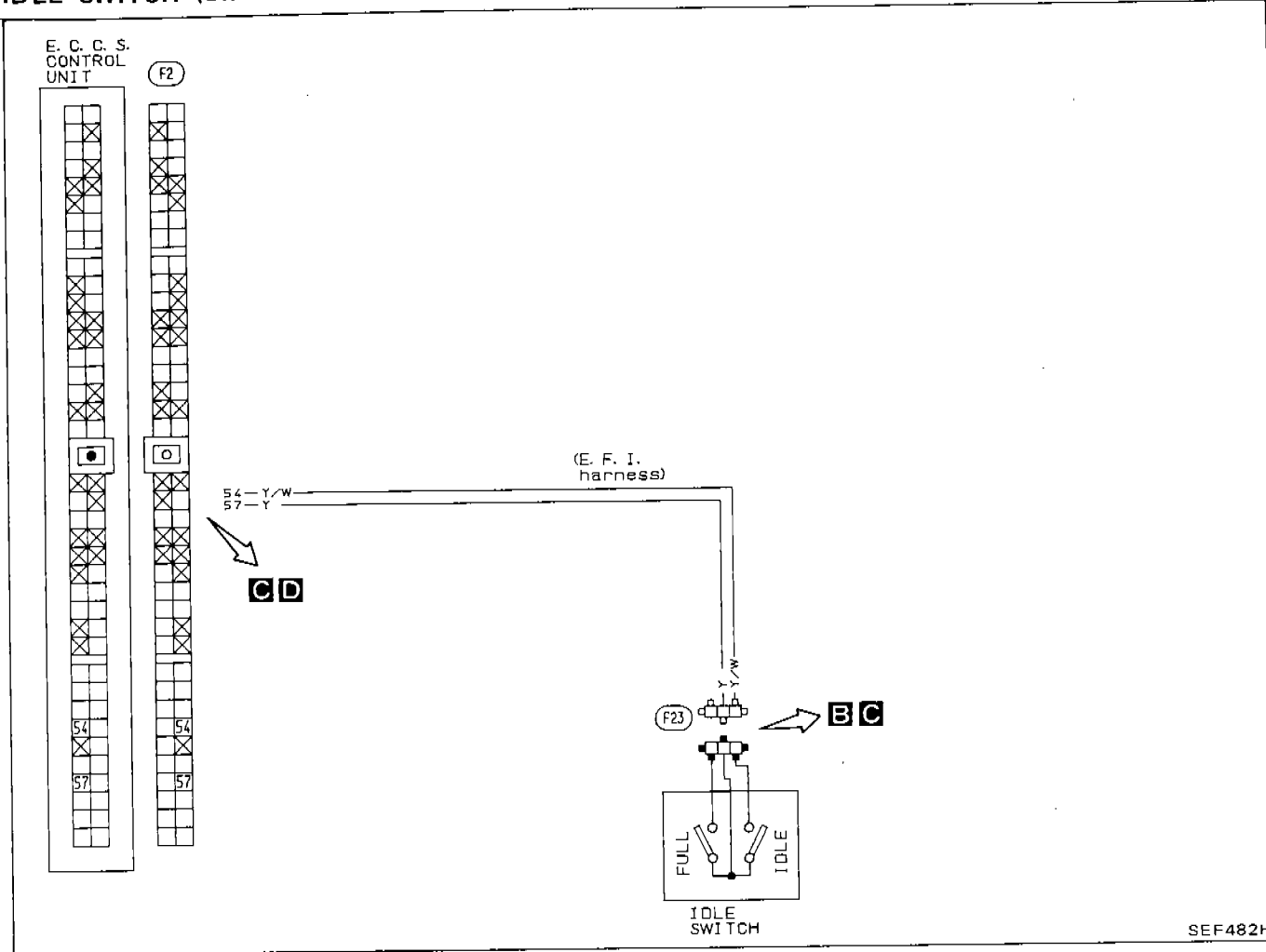

Component location

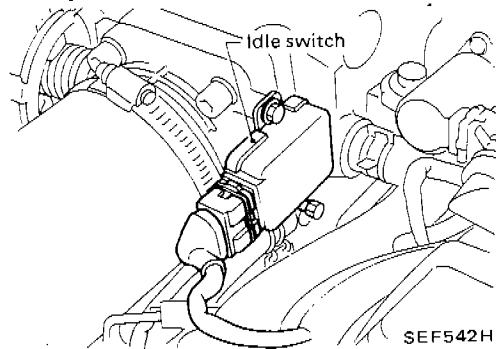

TROUBLE DIAGNOSES

NOTE

EF & EC-93

TROUBLE DIAGNOSES

Diagnostic Procedure 6 (Cont'd)

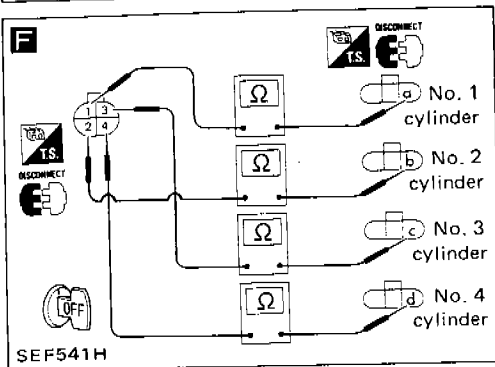
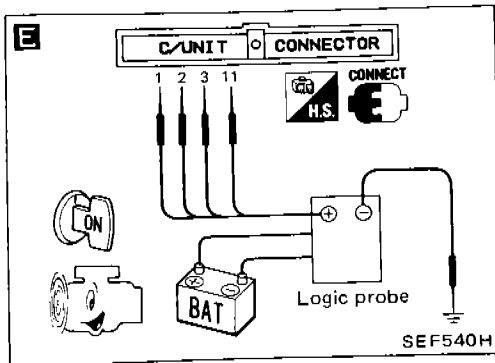

E

CHECK OUTPUT SIGNAL.

- 1) Reconnect power transistor harness connector.
- 2) Reconnect E.C.U. harness connector.
- 3) Reconnect ignition coil harness connector.
- 4) Start engine.
- 5) Make sure that pulse signals exist between E.C.U. terminals ①, ②, ③, ⑪ and ground with logic probe.

Pulse signal should exist.

N.G. → **CHECK COMPONENT**
(Power transistor).
Refer to "Electrical Components Inspection".
(See page EF & EC-125.)

F

CHECK HARNESS CONTINUITY BETWEEN POWER TRANSISTOR AND IGNITION COIL.

- 1) Stop engine and turn ignition switch "OFF".
- 2) Disconnect power transistor harness connector and ignition coil harness connector.
- 3) Check continuity between terminals a and ①, b and ②, c and ③, d and ④.

Continuity:
Approximately 0Ω

N.G. →

- 1) Check middle harness connector.
- 2) Repair harness or connectors.

O.K. → **INSPECTION END**

TROUBLE DIAGNOSES

Diagnostic Procedure 6 (Cont'd)

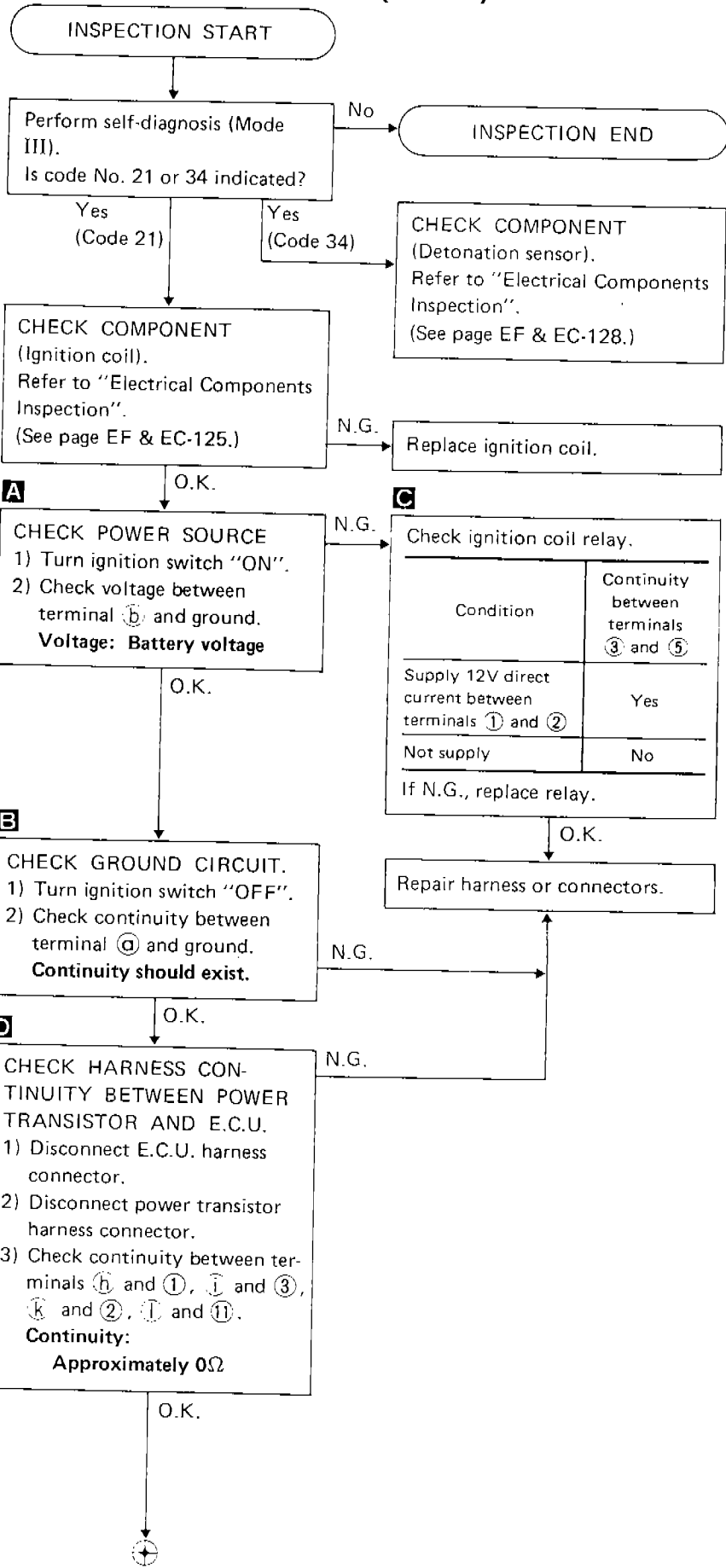
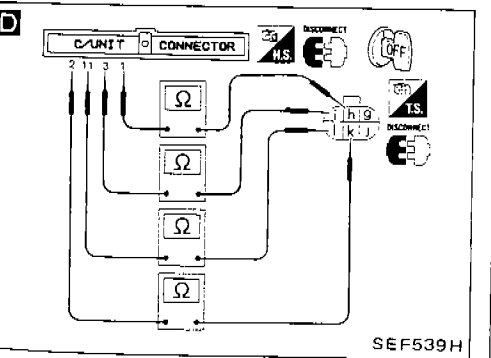
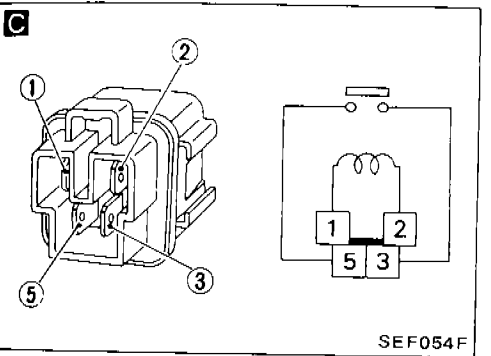
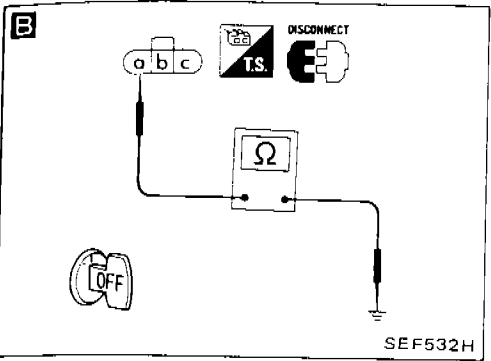
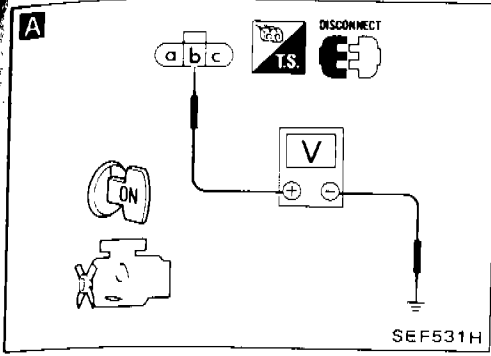

TROUBLE DIAGNOSES

Diagnostic Procedure 6

IGNITION SIGNAL (Code No. 21) & DETONATION SENSOR (Code No. 34)

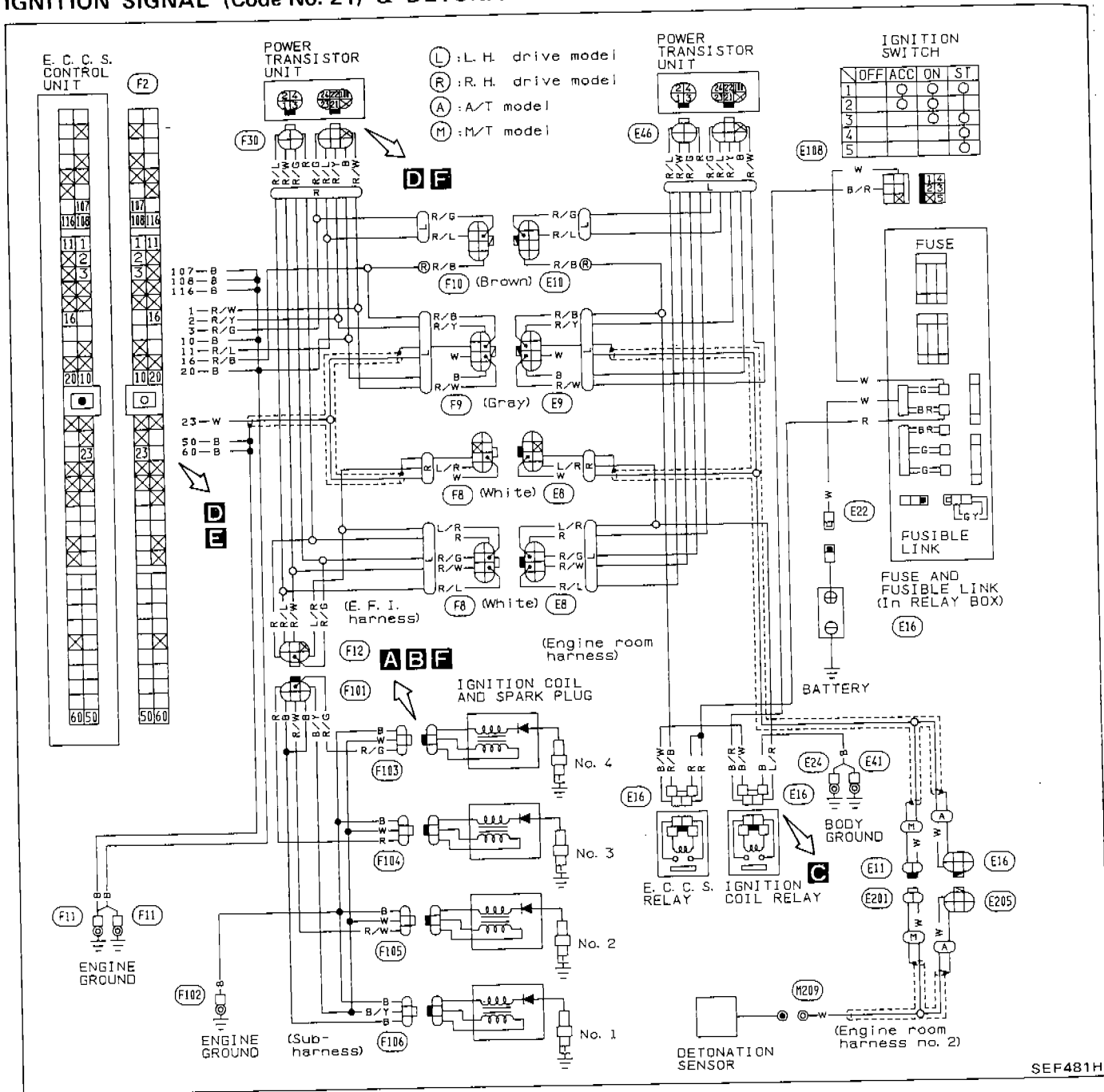

SEF481H

Component location

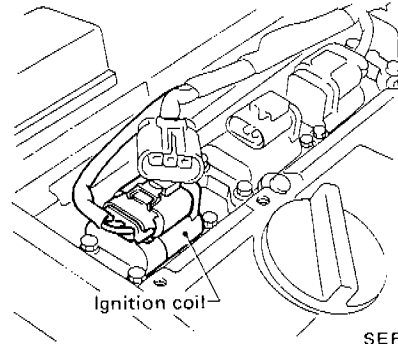
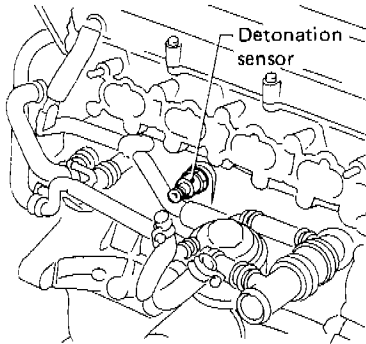
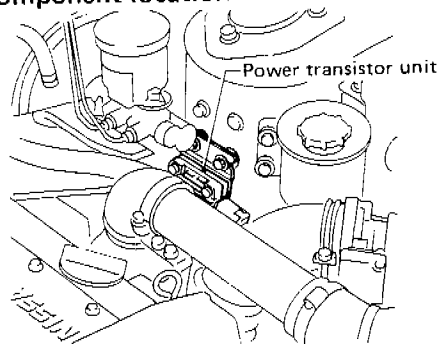

SEF530H

EF & EC-90

TROUBLE DIAGNOSES

Diagnostic Procedure 4 (Cont'd)

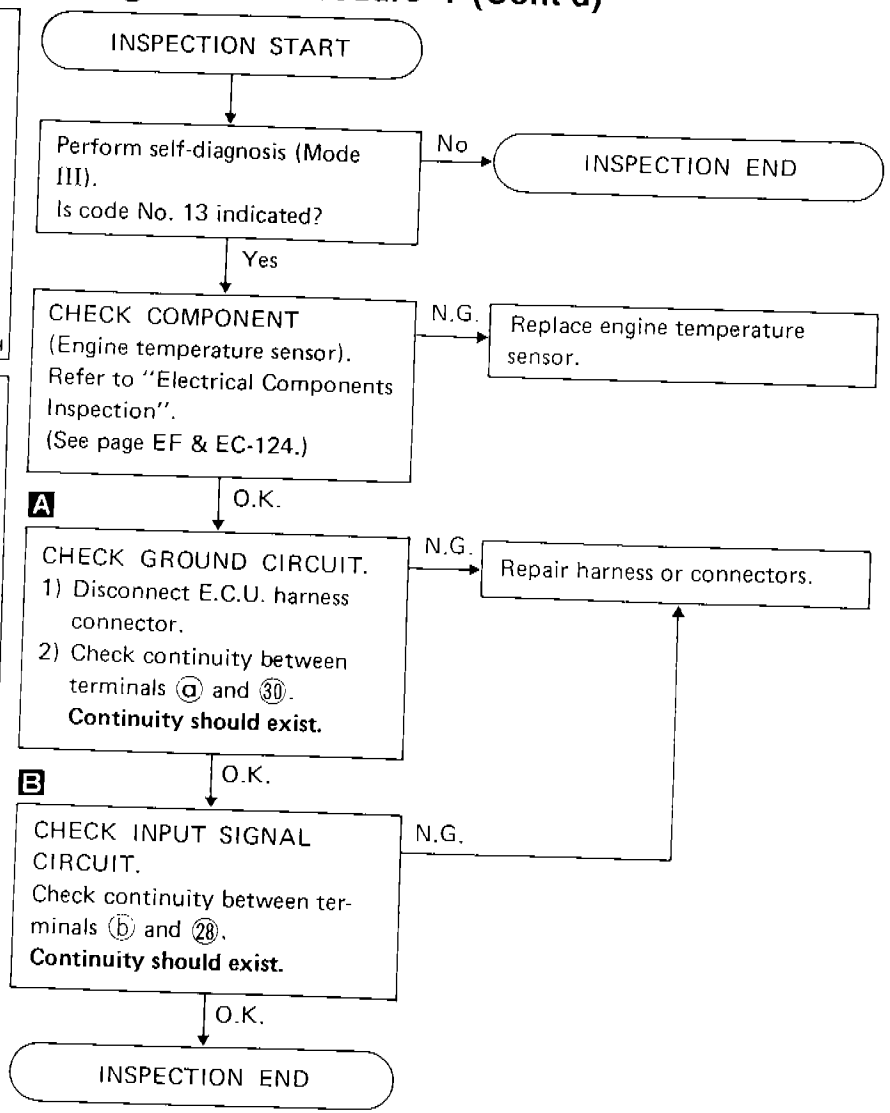
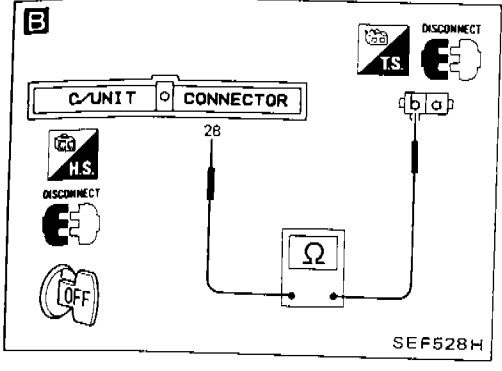
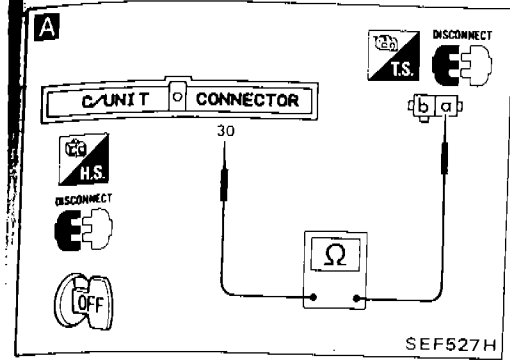

TROUBLE DIAGNOSES

Diagnostic Procedure 4

ENGINE TEMPERATURE SENSOR (Code No. 13)

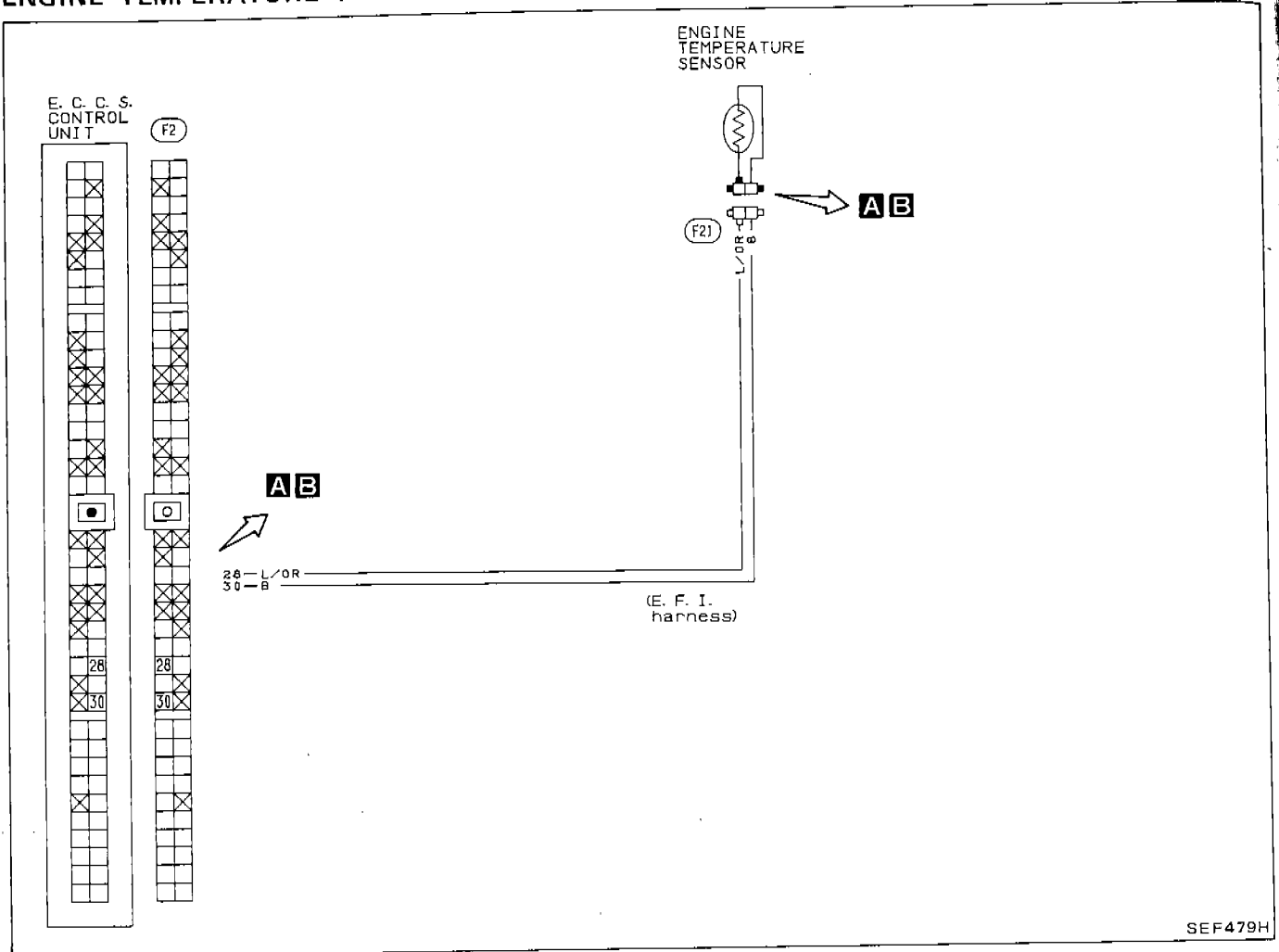

Component location

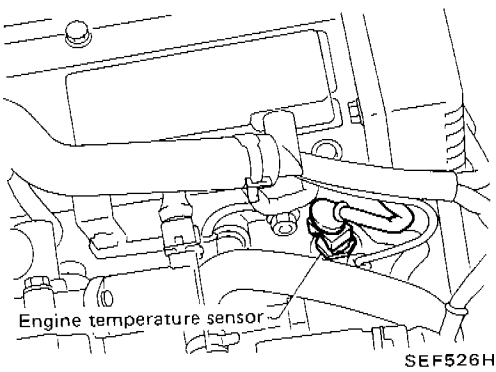

TROUBLE DIAGNOSES

Diagnostic Procedure 3 (Cont'd)

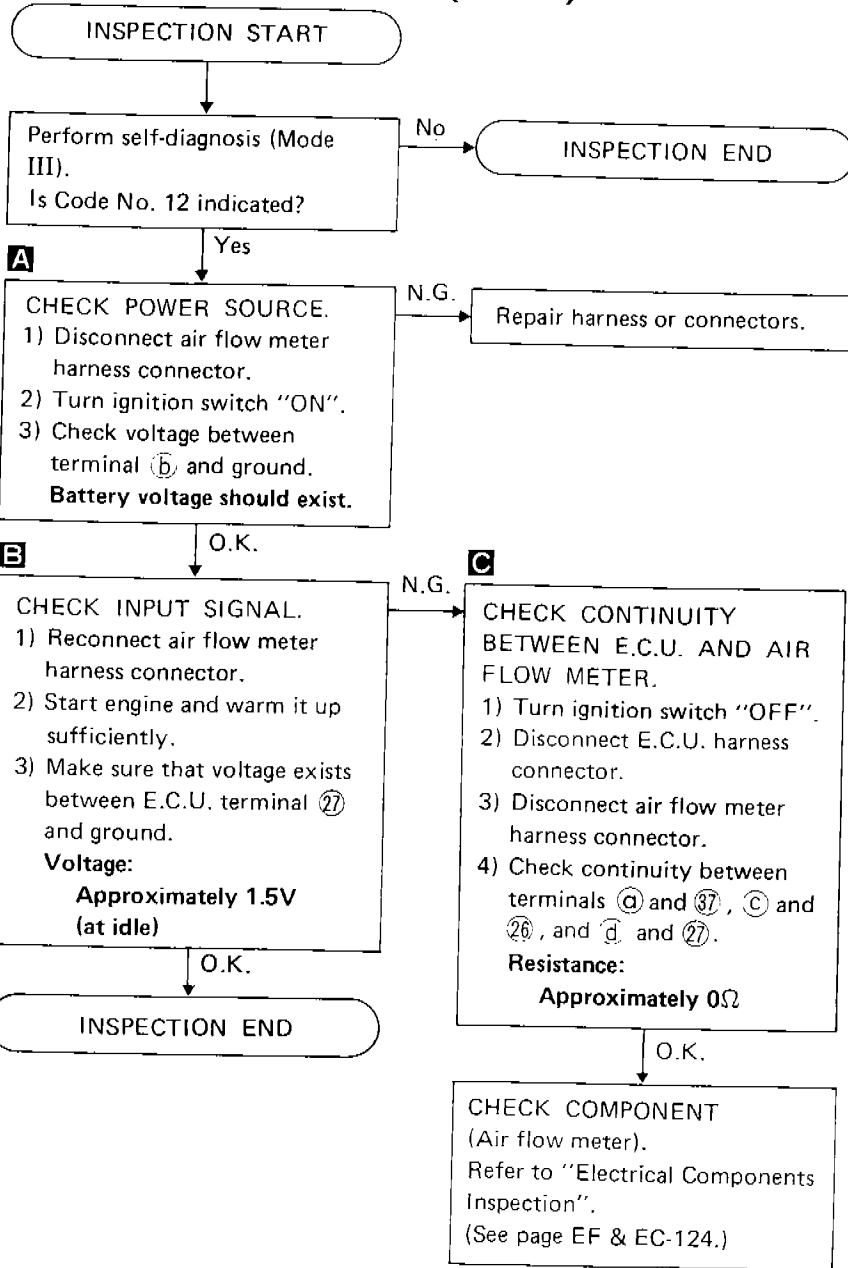
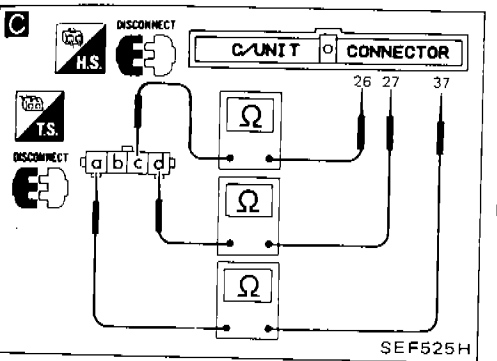
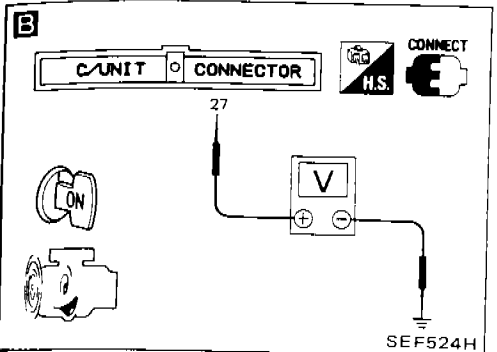
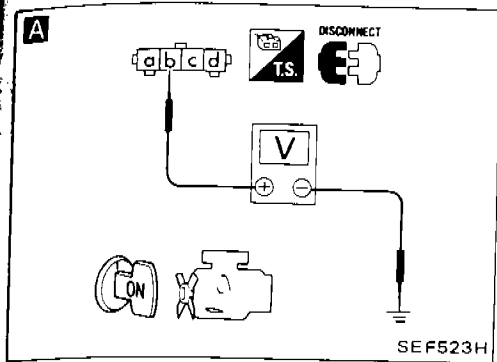

TROUBLE DIAGNOSES

Diagnostic Procedure 3

AIR FLOW METER (Code No. 12)

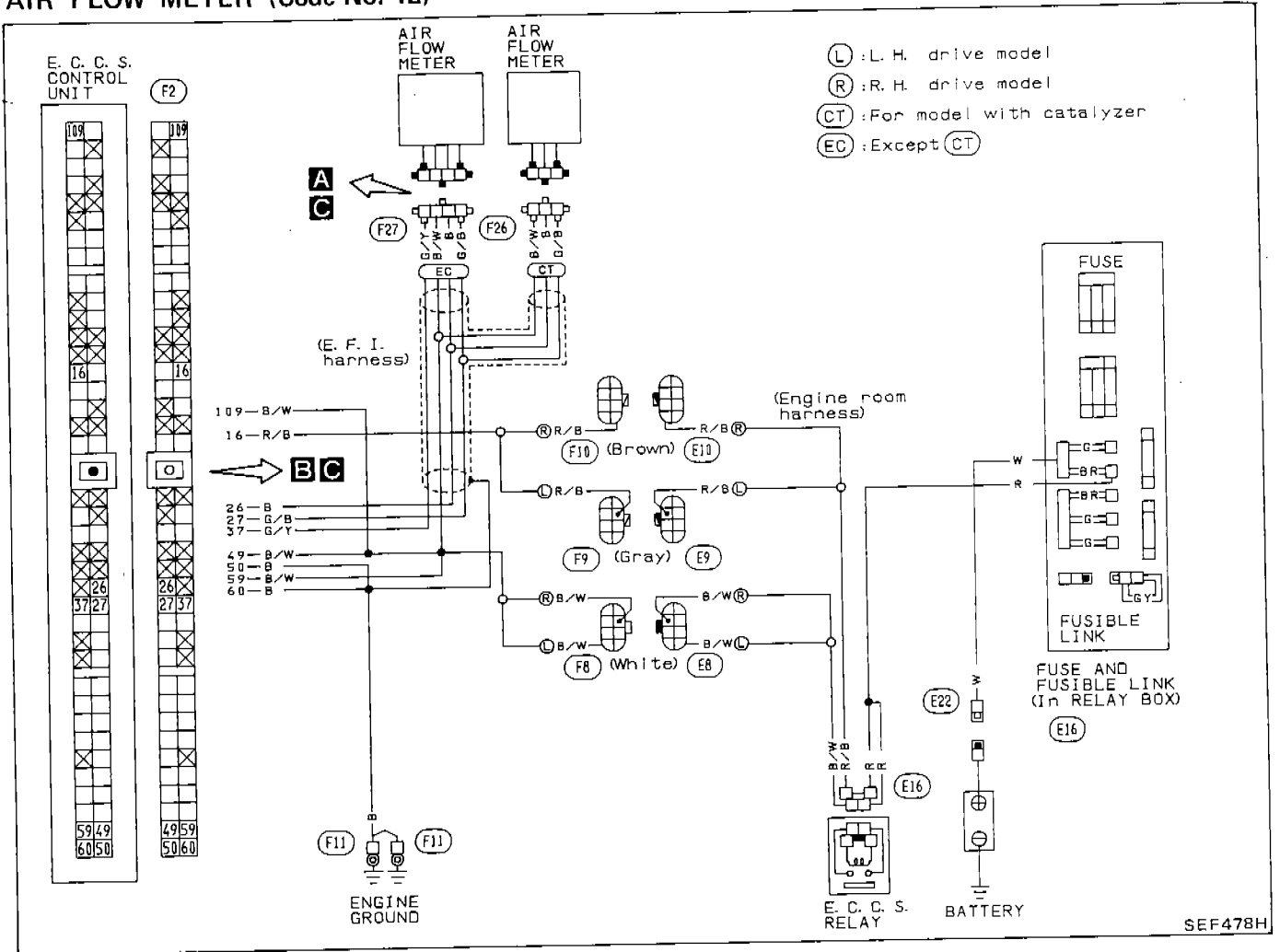

Component location

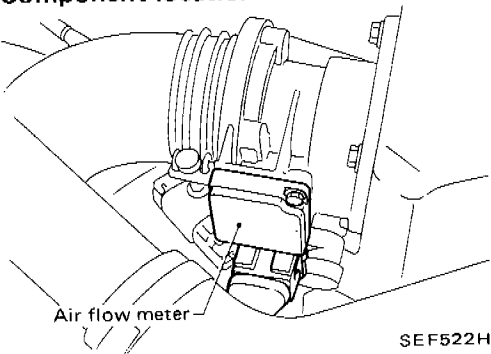

TROUBLE DIAGNOSES

Diagnostic Procedure 2 (Cont'd)

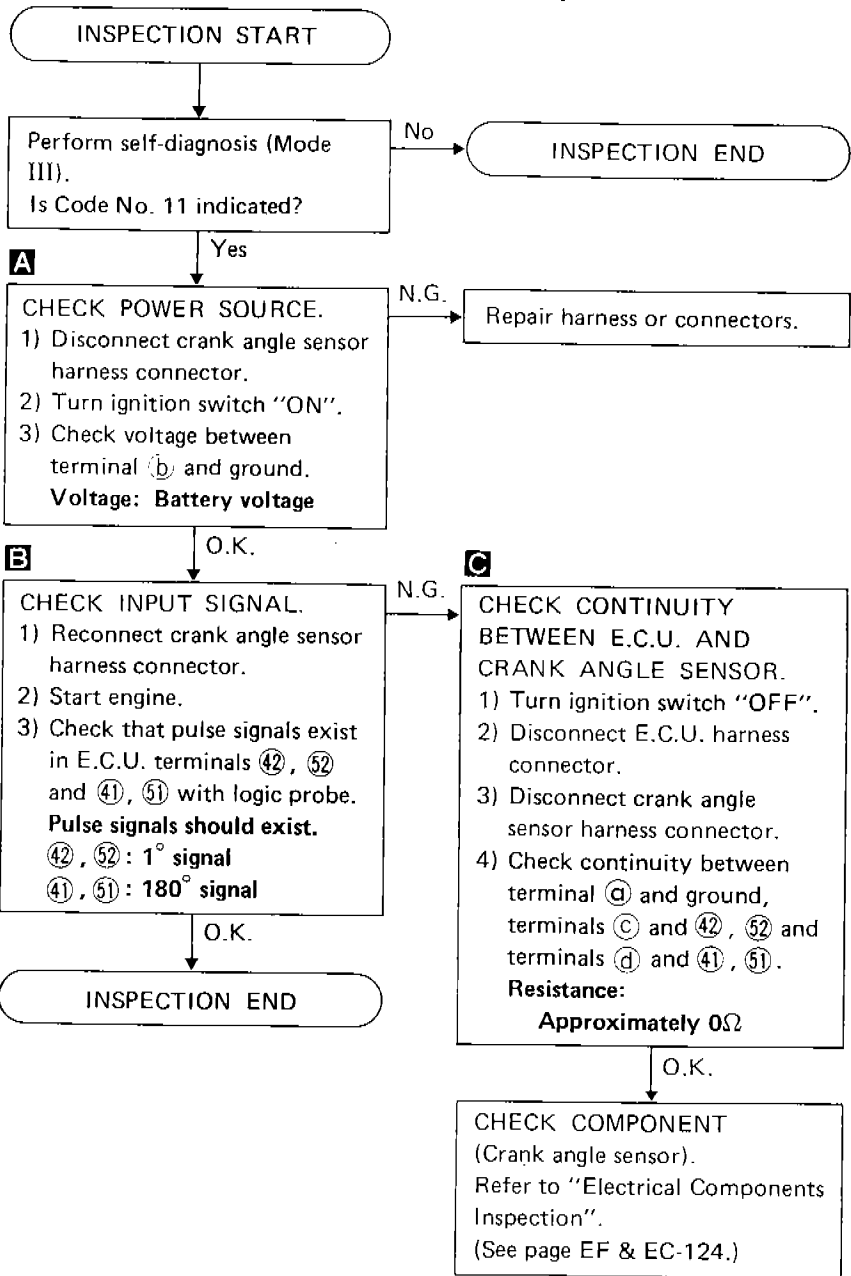
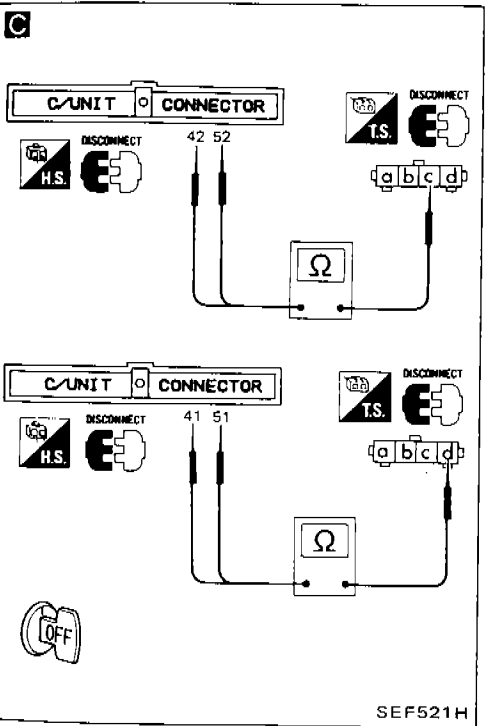
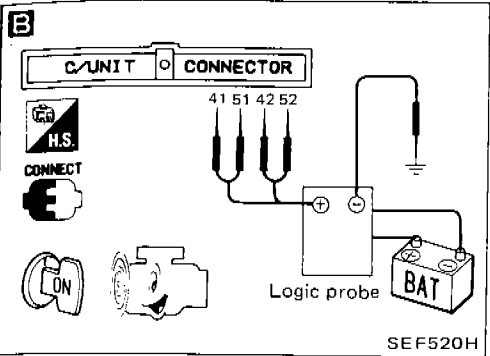
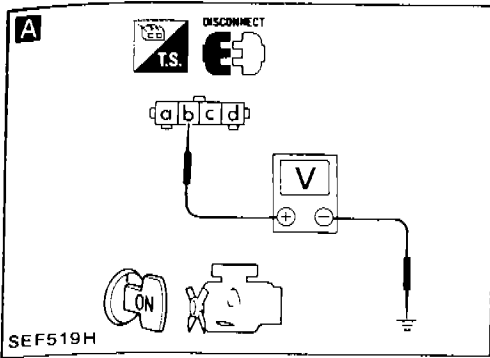

TROUBLE DIAGNOSES

Diagnostic Procedure 2

CRANK ANGLE SENSOR (Code No. 11)

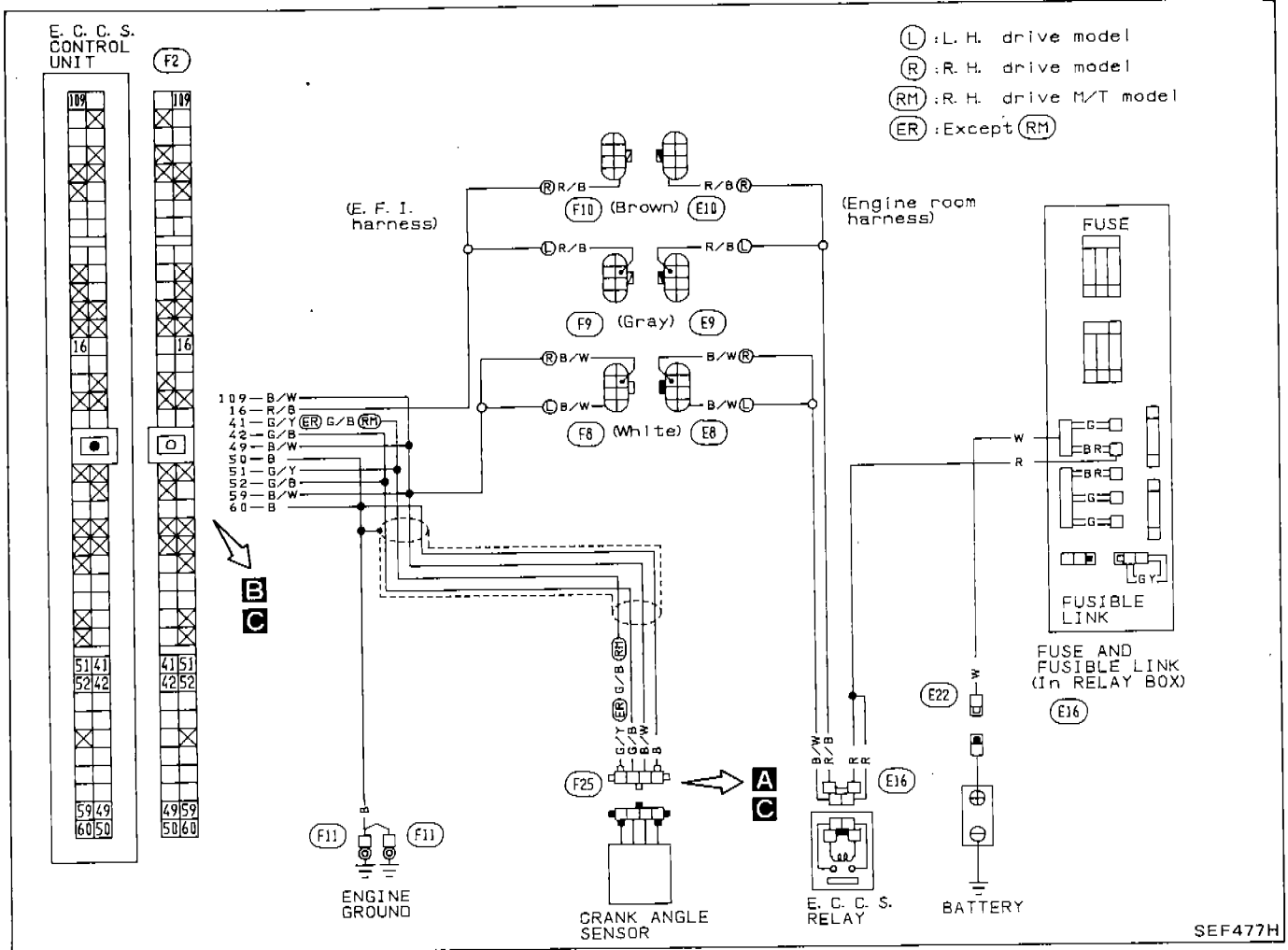

Component location

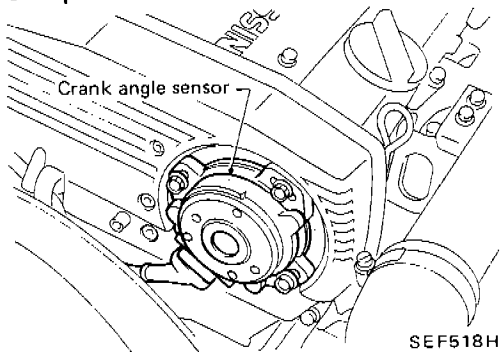

TROUBLE DIAGNOSES

Diagnostic Procedure 1 (Cont'd)

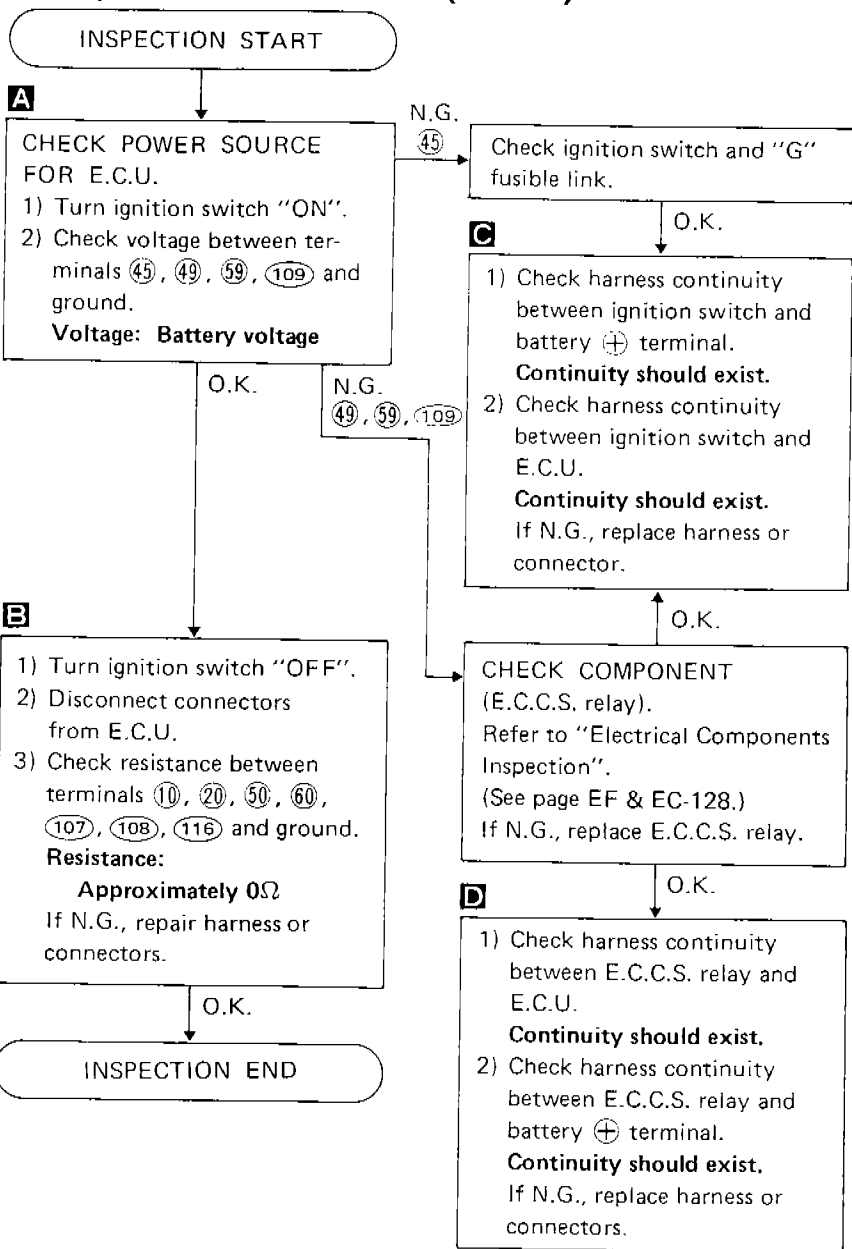
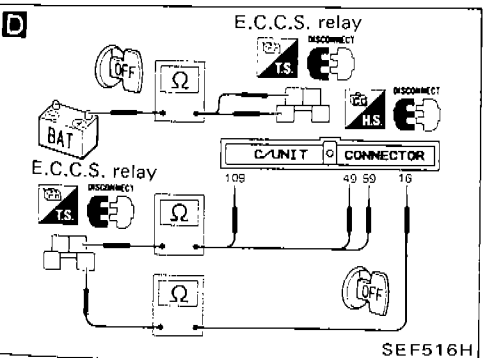
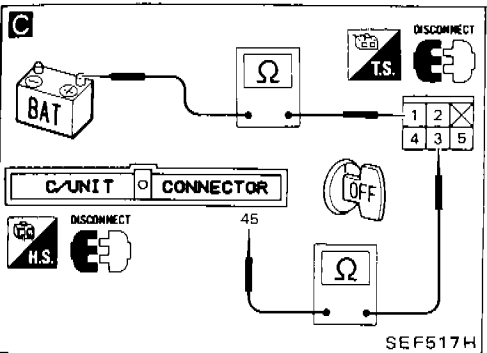
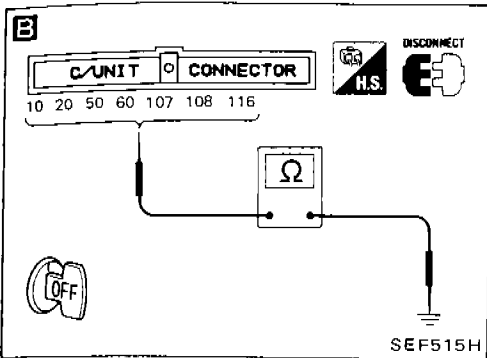
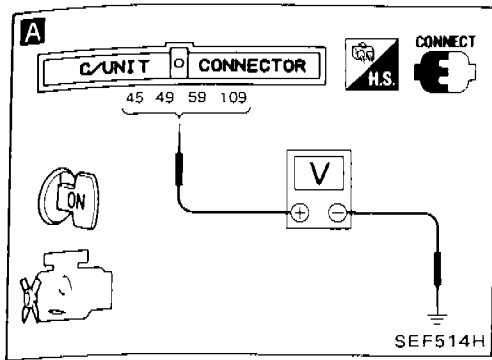

TROUBLE DIAGNOSES

Diagnostic Procedure 1

POWER SOURCE & GROUND CIRCUIT FOR E.C.U. (Not self-diagnostic item)

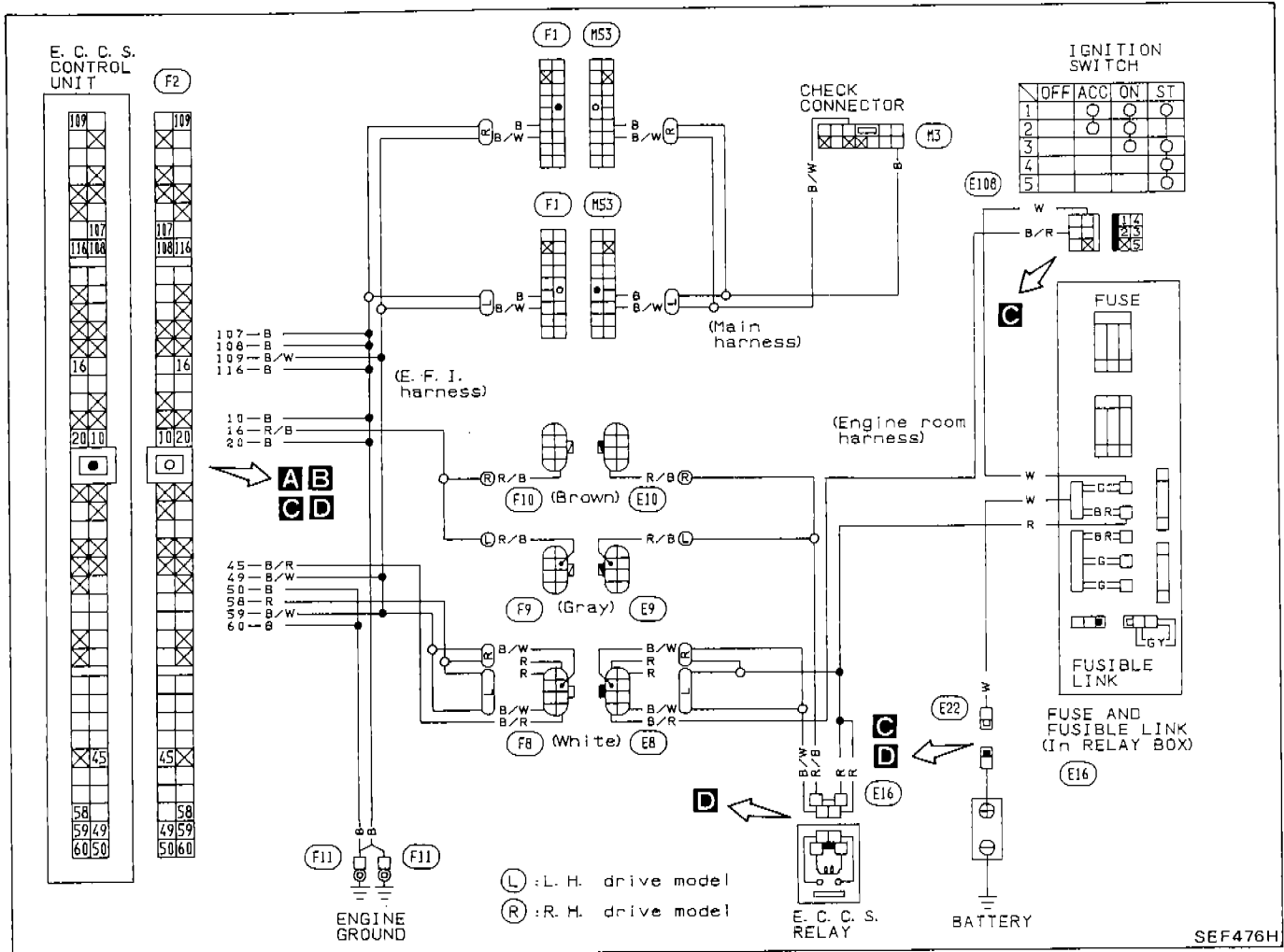

Component location

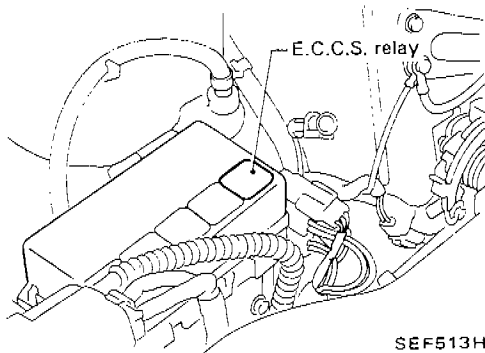

TROUBLE DIAGNOSES

Diagnostic Procedure (Cont'd)

7. When measuring supply voltage of E.C.U. controlled components with a circuit tester, separate one tester probe from the other.

If the two tester probes accidentally make contact with each other during measurement, the circuit will be shorted, resulting in damage to the power transistor of the control unit.

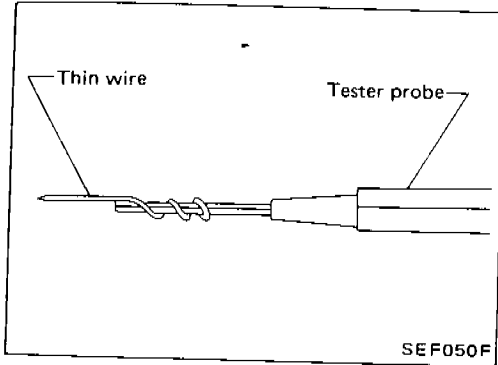
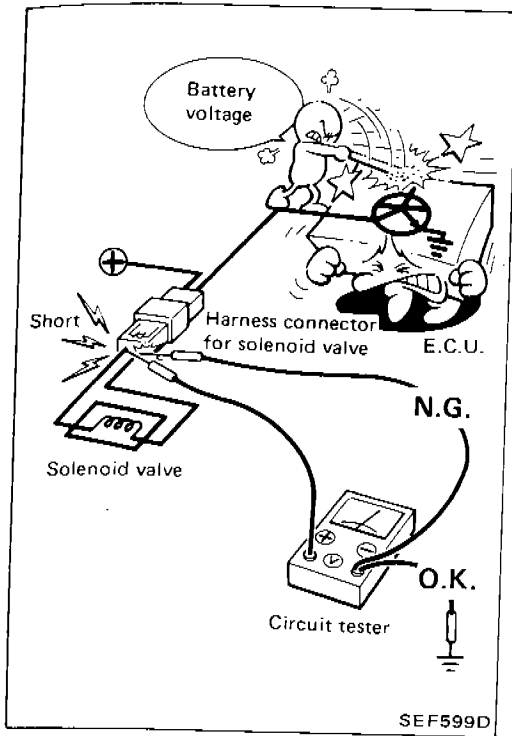

8. Improve tester probe as shown to perform test easily.
9. For the first trouble-shooting procedure, perform **POWER SOURCE & GROUND CIRCUIT FOR E.C.U. check.**

Diagnostic Procedure

CAUTION:

1. Before connecting or disconnecting E.C.U. harness connector to or from any E.C.U., be sure to turn the ignition switch to the "OFF" position and disconnect the negative battery terminal in order not to damage E.C.U. as battery voltage is applied to E.C.U. even if ignition switch is turned off. Otherwise, there may be damage to the E.C.U.
2. When connecting E.C.U. harness connector into E.C.U. or disconnecting it from E.C.U., take care not to damage pin terminal of E.C.U. (Bend or break).
3. Make sure that there are not any bends or breaks on E.C.U. pin terminal, when connecting pin connectors into E.C.U.
4. When connecting E.C.U. harness connector, tighten securing bolt until red projection is in line with connector face.
5. Before replacing E.C.U. perform E.C.U. input/output signal inspection and make sure whether E.C.U. functions properly or not. (See page EF & EC-120.)
6. After performing this "Diagnostic Procedure", perform E.C.C.S. self-diagnosis and driving test.

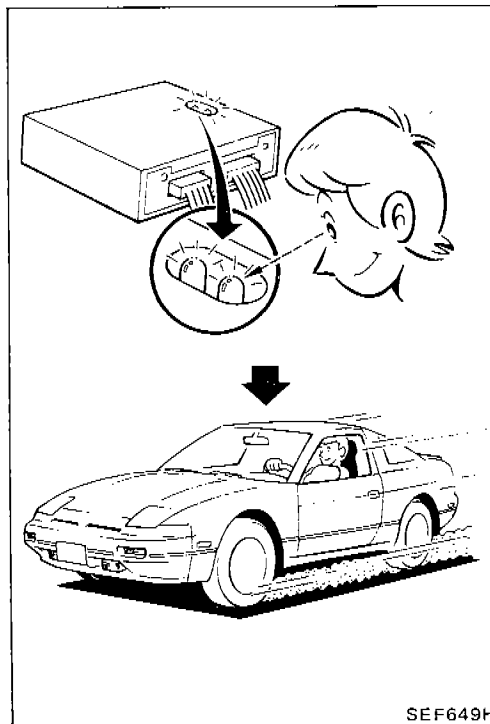
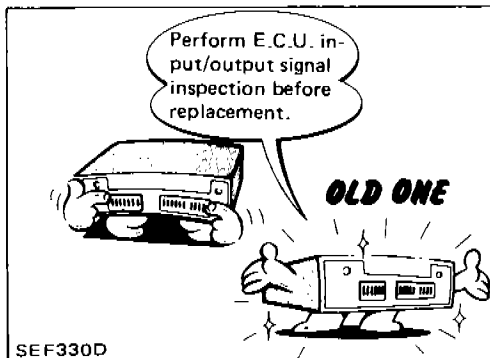
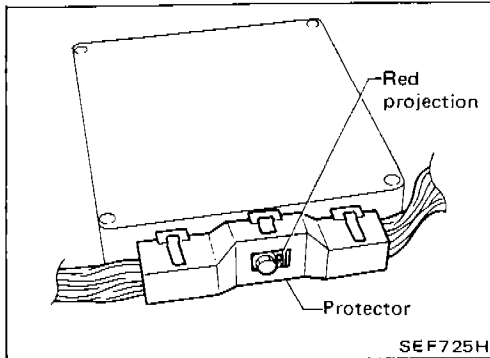
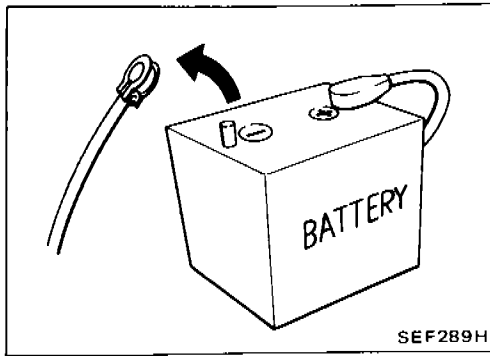

TROUBLE DIAGNOSES

Self-diagnosis — Mode V (Cont'd) REAL-TIME DIAGNOSTIC INSPECTION

X: Available
—: Not available

Crank Angle Sensor, Air Flow Meter and Ignition Signal

| Check sequence | Check items | Check conditions | Check parts | | | If malfunction, perform the following items. |
|----------------|----------------------------------------------------------------------------------|----------------------------|--------------------|-------------------|-------------------|----------------------------------------------------------------------------------|
| | | | Harness connectors | Sensor & actuator | E.C.U. connectors | |
| 1 | Tap harness connector or component during real-time diagnosis. | During real-time diagnosis | X | X | X | Go to check item 2. |
| 2 | Check harness continuity at connector. | Engine stopped | X | — | — | Go to check item 3. |
| 3 | Disconnect harness connector, and then check dust adhesion to harness connector. | Engine stopped | X | — | X | Clean terminal surface. |
| 4 | Check pin terminal bend. | Engine stopped | — | — | X | Take out bend. |
| 5 | Reconnect harness connector and then recheck harness continuity at connector. | Engine stopped | X | — | — | Replace terminal. |
| 6 | Tap harness connector or component during real-time diagnosis. | During real-time diagnosis | X | X | X | If malfunction codes are displayed during real-time diagnosis, replace terminal. |

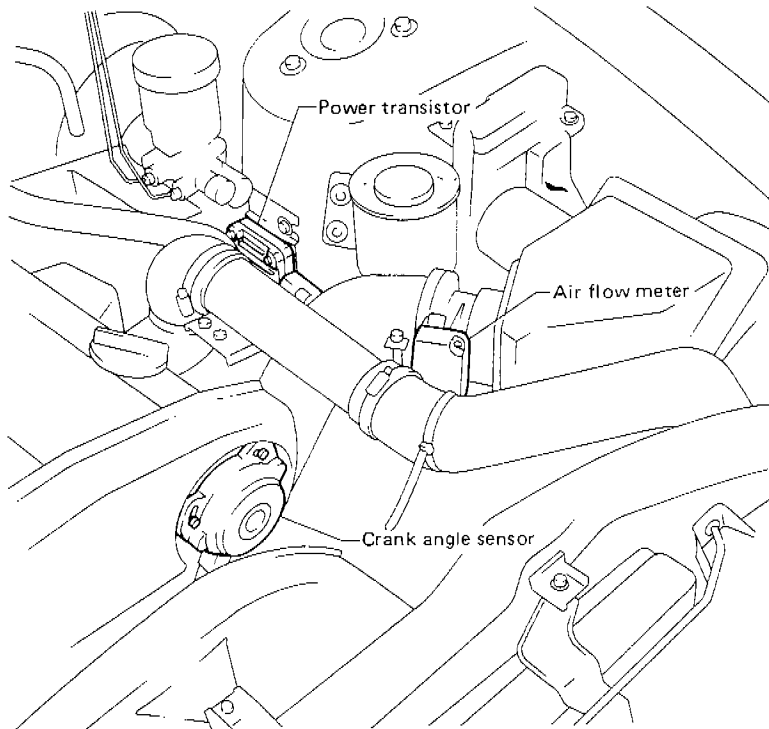

SEF426H

TROUBLE DIAGNOSES

Self-diagnosis — Mode V (Cont'd)

DECODING CHART

Display code

Malfunctioning circuit or parts

Control unit shows a malfunction signal when the following conditions are detected (Compare with Self-diagnosis — Mode III.)

CRANK ANGLE SENSOR

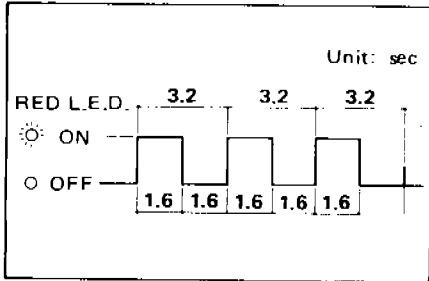

Malfunction of crank angle sensor circuit

- The 1° or 180° signal is momentarily missing, or, multiple, momentary noise signals enter.

REAL-TIME DIAGNOSTIC INSPECTION

See page EF & EC-77.

SEF047F

AIR FLOW METER

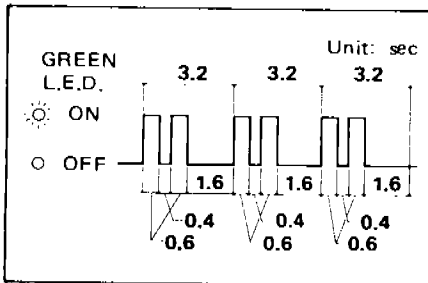

Malfunction of air flow meter circuit

- Abnormal, momentary increase in air flow meter output signal

REAL-TIME DIAGNOSTIC INSPECTION

See page EF & EC-77.

SEF048F

IGNITION SIGNAL

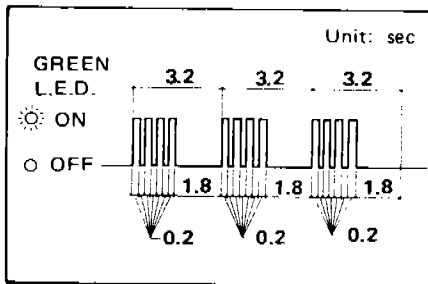

Malfunction of ignition signal

- Signal from the primary ignition coil momentarily drops off.

REAL-TIME DIAGNOSTIC INSPECTION

See page EF & EC-77.

SEF049F

TROUBLE DIAGNOSES

Self-diagnosis — Mode V

In real-time diagnosis, if any of the following items are judged to be faulty, a malfunction is indicated immediately.

- Crank angle sensor (180° signal & 1° signal)
- Ignition signal
- Air flow meter output signal

Consequently, this diagnosis is a very effective measure to diagnose whether the above systems cause the malfunction or not, during driving test. Compared with self-diagnosis, real-time diagnosis is very sensitive, and can detect malfunctioning conditions in a moment. Further, items regarded to be malfunctions in this diagnosis are not stored in E.C.U. memory.

SELF-DIAGNOSTIC PROCEDURE

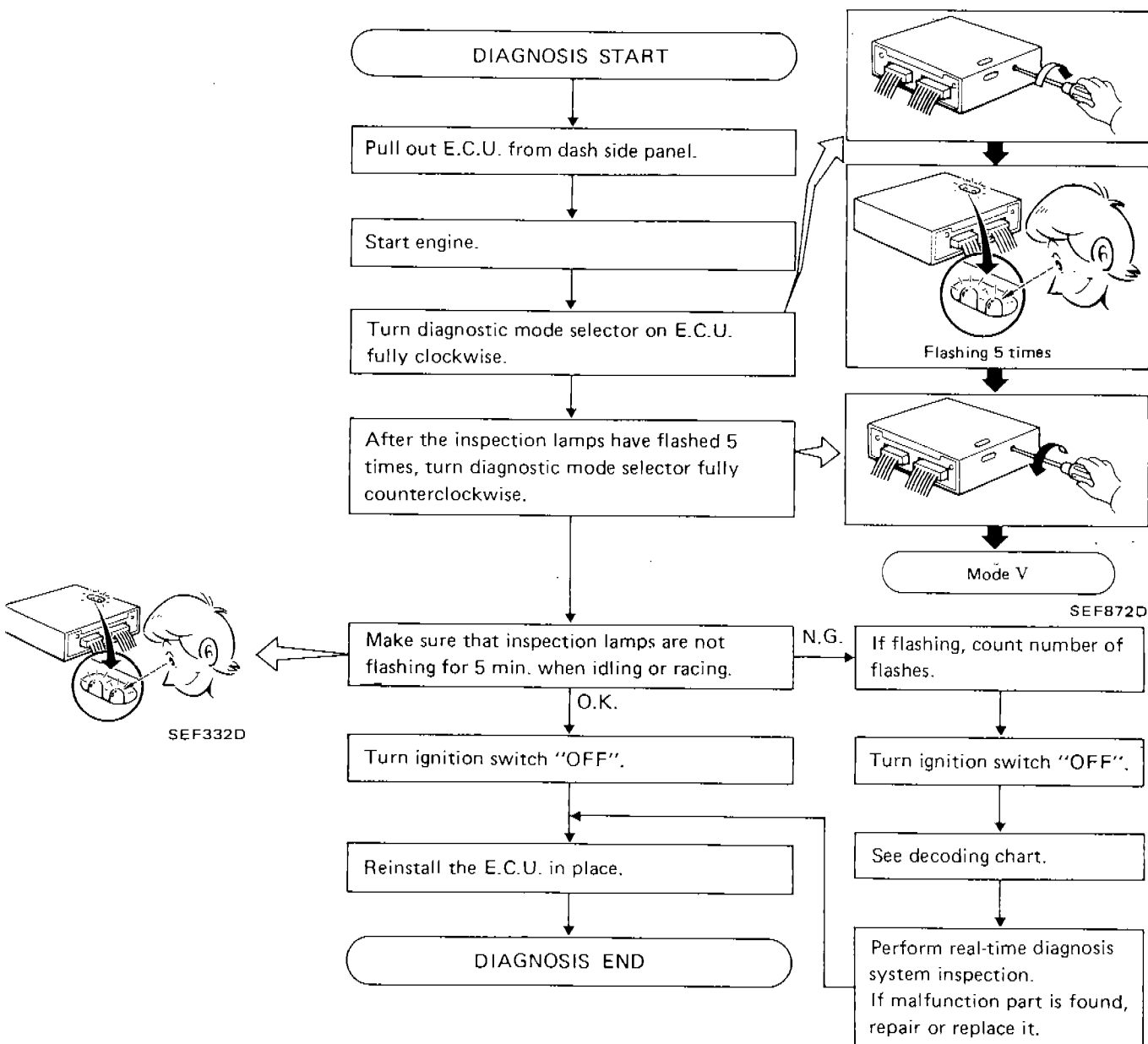

CAUTION:
In real-time diagnosis, pay attention to inspection lamp flashing. E.C.U. displays the malfunction code only once, and does not memorize the inspection.

TROUBLE DIAGNOSES

Self-diagnosis — Mode IV (Cont'd)

SELF-DIAGNOSTIC PROCEDURE

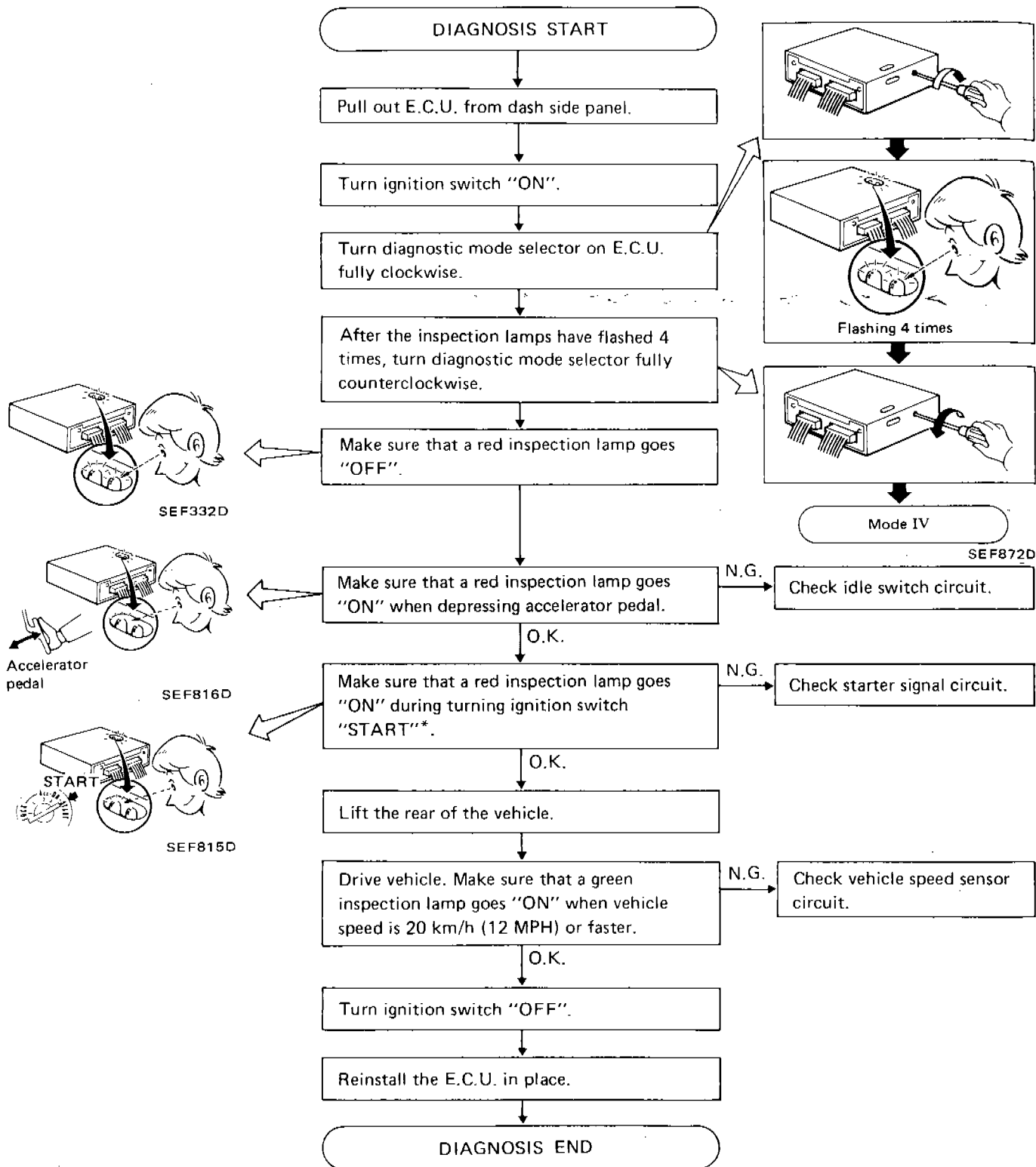

CAUTION:

- *If ignition switch is turned to "START" an even number of times, a red inspection lamp goes "OFF" when depressing accelerator pedal.
- For safety, do not turn front wheel at higher speed than required.

Self-diagnosis — Mode IV

In switches ON/OFF diagnosis system, ON/OFF operation of the following switches can be detected continuously.

- Idle switch
- Ignition switch "START"
- Vehicle speed sensor

(1) Idle switch & Ignition switch "START"

The switches ON/OFF status at the point when mode IV is selected is stored in E.C.U. memory. When either switch is turned from "ON" to "OFF" or "OFF" to "ON", the red L.E.D. on E.C.U. alternately comes on and goes off each time switching is detected.

(2) Vehicle speed sensor

The switches ON/OFF status at the point when mode IV is selected is stored in E.C.U. memory. When vehicle speed is 20 km/h (12 MPH) or slower, the green L.E.D. on E.C.U. is off. When vehicle speed exceeds 20 km/h (12 MPH), the green L.E.D. on E.C.U. comes "ON".

TROUBLE DIAGNOSES

Self-diagnosis — Mode III (Cont'd)

Display code

Malfunctioning circuit or parts

Control unit shows a malfunction signal when the following conditions are detected.

DETONATION SENSOR

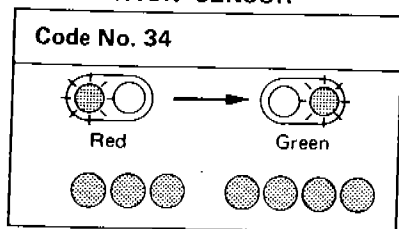

Detonation sensor circuit

- The detonation sensor circuit is open or shorted.

SYSTEM INSPECTION
See page EF & EC-90.

SEF132F

THROTTLE SENSOR

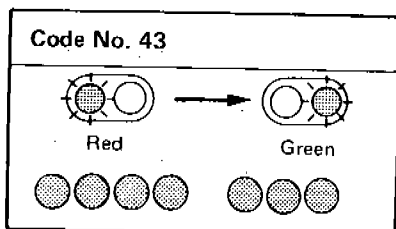

Throttle sensor circuit

- Throttle sensor circuit is open or short.
(Output voltage is too high or too low.)

SYSTEM INSPECTION
See page EF & EC-98.

SEF079G

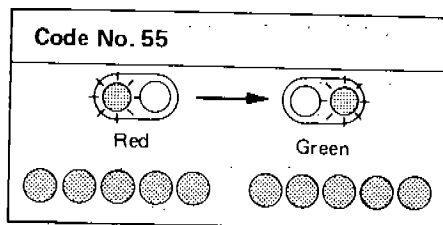

E.C.C.S.
normal
operation.

SEF984F

Self-diagnosis — Mode IV

In switches ON/OFF diagnosis system, ON/OFF operation of the following switches can be detected continuously.

- Idle switch
- Ignition switch "START"
- Vehicle speed sensor

(1) Idle switch & Ignition switch "START"

The switches ON/OFF status at the point when mode IV is selected is stored in E.C.U. memory. When either switch is turned from "ON" to "OFF" or "OFF" to "ON", the red L.E.D. on E.C.U. alternately comes on and goes off each time switching is detected.

(2) Vehicle speed sensor

The switches ON/OFF status at the point when mode IV is selected is stored in E.C.U. memory. When vehicle speed is 20 km/h (12 MPH) or slower, the green L.E.D. on E.C.U. is off. When vehicle speed exceeds 20 km/h (12 MPH), the green L.E.D. on E.C.U. comes "ON".

TROUBLE DIAGNOSES

Self-diagnosis — Mode III (Cont'd)

Display code

Malfunctioning circuit or parts

Control unit shows a malfunction signal when the following conditions are detected.

DETONATION SENSOR

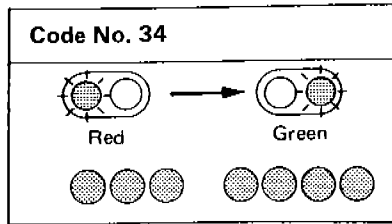

Detonation sensor circuit

- The detonation sensor circuit is open or shorted.

SYSTEM INSPECTION
See page EF & EC-90.

SEF132F

THROTTLE SENSOR

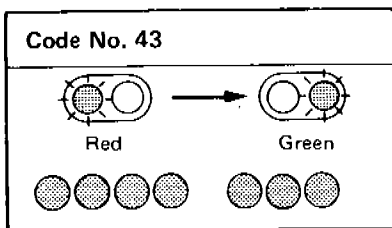

Throttle sensor circuit

- Throttle sensor circuit is open or short.
(Output voltage is too high or too low.)

SYSTEM INSPECTION
See page EF & EC-98.

SEF079G

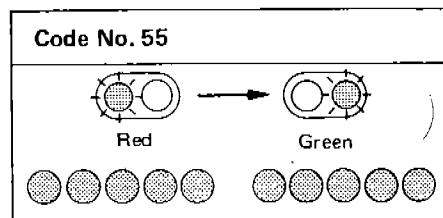

E.C.C.S.
normal
operation.

SEF984F

TROUBLE DIAGNOSES

Self-diagnosis — Mode III (Cont'd)

DECODING CHART

Display code

Malfunctioning circuit or parts

Control unit shows a malfunction signal when the following conditions are detected.

CRANK ANGLE SENSOR

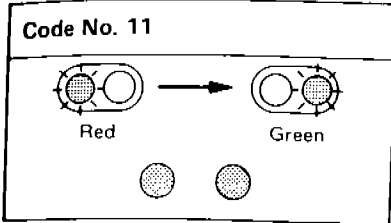

Crank angle sensor circuit

- Either 1° or 180° signal is not entered for the first few seconds during engine cranking.
- Either 1° or 180° signal is not input often enough while the engine speed is higher than the specified rpm.

SYSTEM INSPECTION
See page EF & EC-82.

SEF042F

AIR FLOW METER

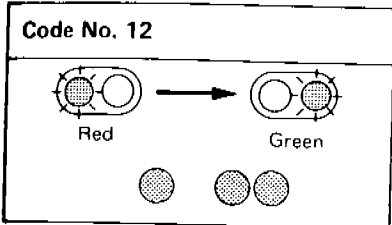

Air flow meter circuit

- The air flow meter circuit is open or shorted. (An abnormally high or low voltage is entered.)

SYSTEM INSPECTION
See page EF & EC-84.

SEF043F

ENGINE TEMPERATURE SENSOR

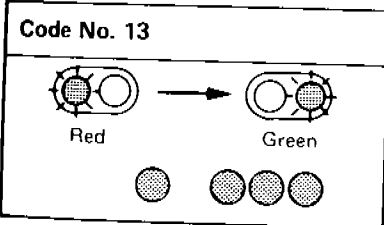

Engine temperature sensor circuit

- The engine temperature sensor circuit is open or shorted. (An abnormally high or low output voltage is entered.)

SYSTEM INSPECTION
See page EF & EC-86.

SEF044F

IGNITION SIGNAL

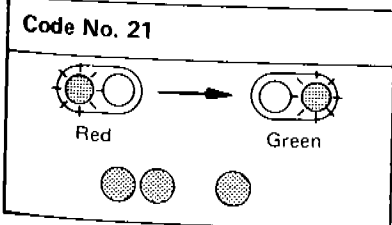

Ignition signal circuit

- The circuit between power transistor unit and E.C.U. is opened.

SYSTEM INSPECTION
See page EF & EC-90.

SEF045F

TROUBLE DIAGNOSES

Self-diagnosis — Mode III (Cont'd) SELF-DIAGNOSTIC PROCEDURE

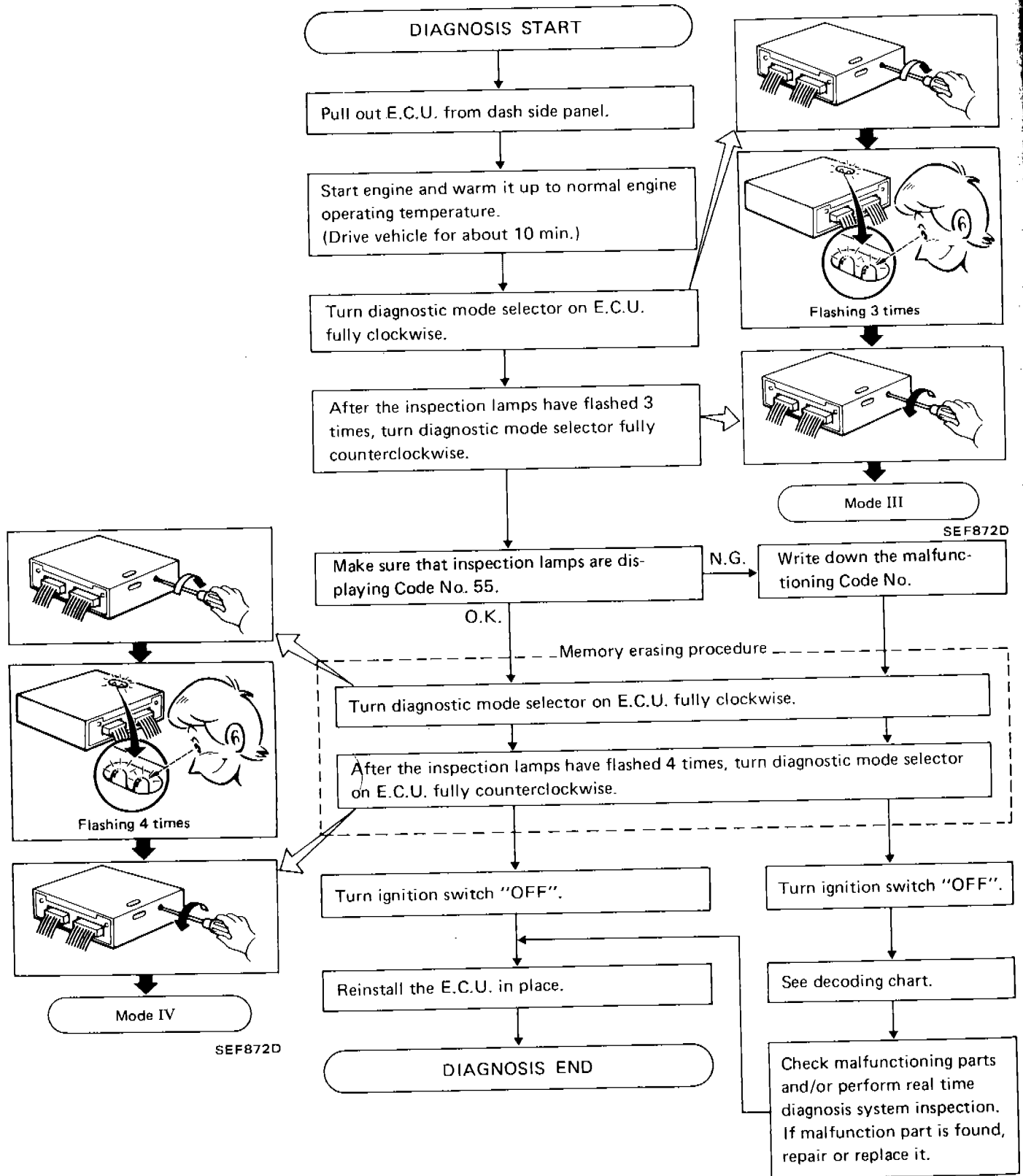

CAUTION:

During displaying Code No. in self-diagnosis mode (Mode III), if the other diagnostic mode should be done, make sure to write down the malfunctioning Code No. before turning diagnostic mode selector on E.C.U. fully clockwise, or select the diagnostic mode after turning switch "OFF". Otherwise self-diagnosis information stored in E.C.U. memory until now would be lost.

TROUBLE DIAGNOSES

Self-diagnosis — Mode III (Cont'd)

RETENTION OF DIAGNOSTIC RESULTS

The diagnostic result is retained in E.C.U. memory until the starter is operated fifty times after a diagnostic item is judged to be malfunctioning. The diagnostic result will then be cancelled automatically. If a diagnostic item which has been judged to be malfunctioning and stored in memory is again judged to be malfunctioning before the starter is operated fifty times, the second result will replace the previous one. It will be stored in E.C.U. memory until the starter is operated fifty times more.

RETENTION TERM CHART (Example)

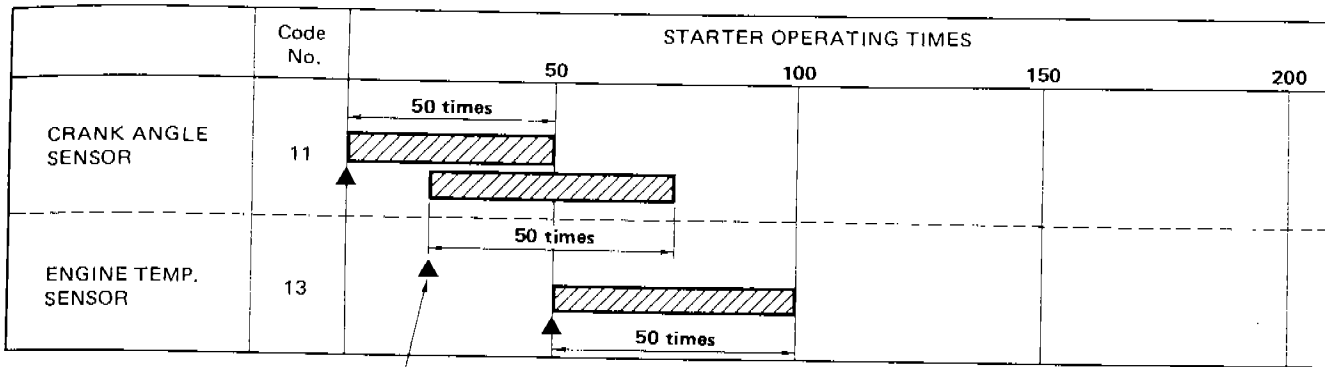

: Retention term



: Malfunction detecting point

If the same diagnostic item is judged to be malfunctioning before the starter is operated fifty times, it will be stored in E.C.U. memory until the starter is operated fifty times from this point in time.

SEF793D

Self-diagnosis — Mode III

The E.C.U. constantly monitors the function of these sensors and actuators, regardless of ignition key position. If a malfunction occurs, the information is stored in the E.C.U. and can be retrieved from the memory by turning on the diagnostic mode selector, located on the side of the E.C.U. When activated, the malfunction is indicated by flashing a red and a green L.E.D. (Light Emitting Diode), also located on the E.C.U. Since all the self-diagnostic results are stored in the E.C.U.'s memory even intermittent malfunctions can be diagnosed.

A malfunctioning part's group is indicated by the number of both the red and the green L.E.D.s flashing. First, the red L.E.D. flashes and the green flashes follow. The red L.E.D. refers to the number of tens while the green one refers to the number of units. For example, when the red L.E.D. flashes once and then the green one flashes twice, this means the number "12" showing the air flow meter signal is malfunctioning. In this way, all the problems are classified by the code numbers.

- When engine fails to start, crank engine more than two seconds before starting self-diagnosis.
- Before starting self-diagnosis, do not erase stored memory. If doing so, self-diagnosis function for intermittent malfunctions would be lost.

The stored memory would be lost if:

1. Battery terminal is disconnected.
2. After selecting Mode III, Mode IV is selected.

DISPLAY CODE TABLE

| Code No. | Detected items |
|----------|----------------------------------------|
| 11 | Crank angle sensor circuit |
| 12 | Air flow meter circuit |
| 13 | Engine temperature sensor circuit |
| 21 | Ignition signal circuit |
| 34 | Detonation sensor circuit |
| 43 | Throttle sensor circuit |
| 55 | No malfunctioning in the above circuit |

TROUBLE DIAGNOSES

Self-diagnosis — Modes I & II (Model with catalyzer)

In these modes, the control unit provides the mixture ratio monitor presentation and the mixture ratio feedback coefficient monitor presentation.

| Mode | L.E.D. | Engine stopped (Ignition switch "ON") | Engine running | | | |
|------------------------|--------|------------------------------------------|--------------------------------------------------------|-----------------------------------|--------------------------------|------|
| | | | Open loop condition | | Closed loop condition | |
| Mode I (Monitor A) | Green | ON | * Remains ON or OFF | | Blinks | |
| | Red | ON | OFF | | | |
| Mode II (Monitor B) | Green | ON | * Remains ON or OFF | | Blinks | |
| | Red | OFF | * Remains ON or OFF (synchronous with green L.E.D.) | Compensating mixture ratio | | |
| | | | | More than 5% rich | Between 5% lean and 5% rich | More |
| | | | OFF | Synchronized with green L.E.D. | Remains ON | |

*Maintains conditions just before switching to open loop

Modes I & II are not available for non-catalyzer model.

TROUBLE DIAGNOSES

Self-diagnosis — Description (Cont'd)

CHECKER BOX

The Checker Box is used to control and read the self-diagnosis systems on models equipped with the "check connector" harness. It is a tool which can be used to operate the self-diagnosis system easily.

The Checker Box switch is used to trigger each of the self-diagnosis modes. You can read the red and green light emitting diode (L.E.D.) codes in the Checker Box, so it is not necessary to remove the E.C.U. The Checker Box also has an audible tone for each L.E.D. signal, so you can "hear" the codes instead of looking at the L.E.D. if necessary.

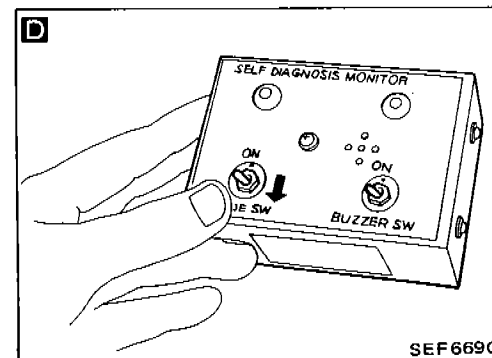
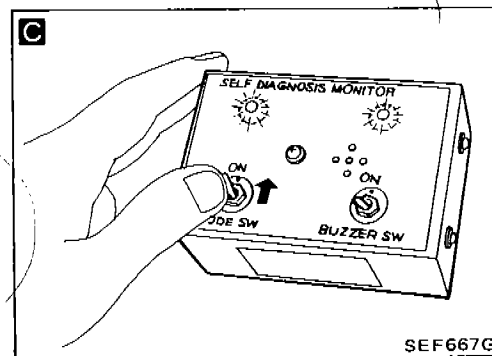
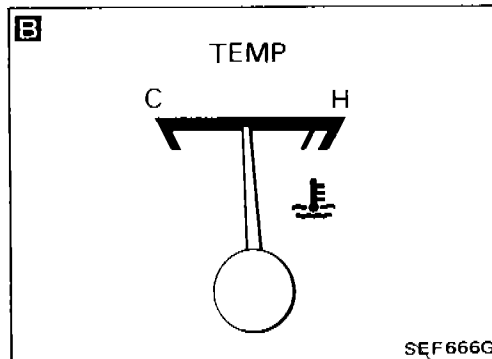
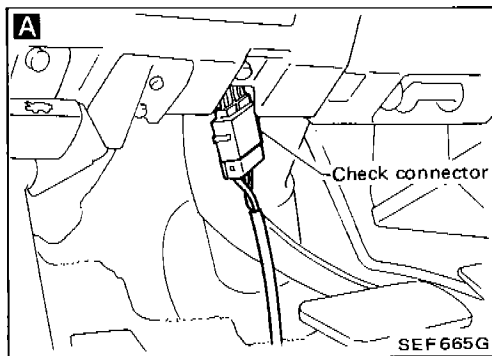
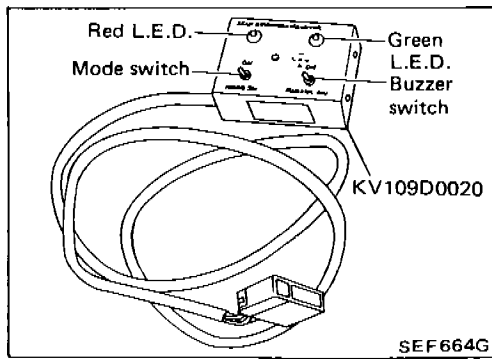

Self-diagnostic procedure

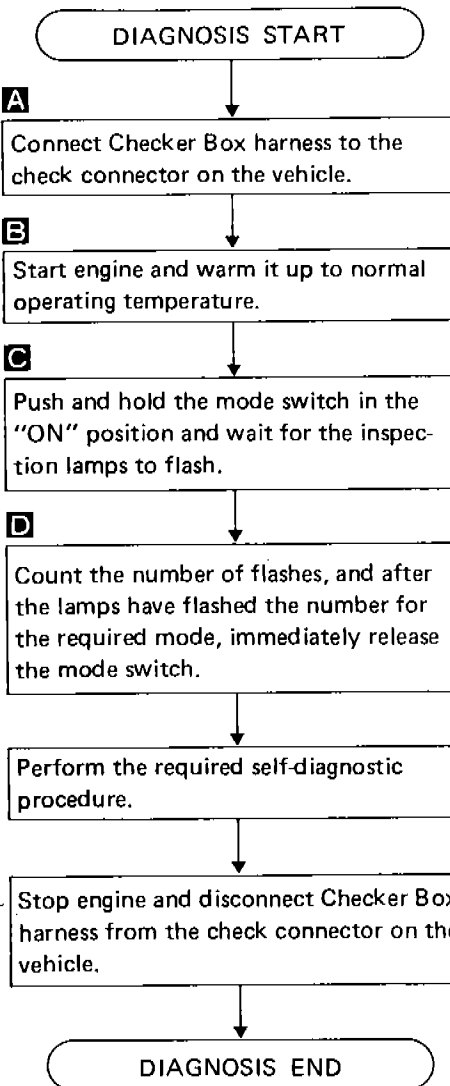

- Connect the Checker Box to the check connector only when the ignition key is in the "OFF" position.

- You can erase the stored memory by changing from diagnostic mode to Mode IV using the mode switch on the Checker Box.

- Disconnect the Checker Box from the check connector only when the ignition key is in the "OFF" position and the inspection lamps turn off.

Service procedures and instructions except for the above are the same as those where Checker Box is not used.

TROUBLE DIAGNOSES

Self-diagnosis — Description (Cont'd)

SWITCHING THE MODES

1. Turn ignition switch "ON".
2. Turn diagnostic mode selector on E.C.U. fully clockwise and wait the inspection lamps flash.
3. Count the number of the flashing time, and after the inspection lamps have flashed the number of the required mode, turn diagnostic mode selector fully counterclockwise immediately.

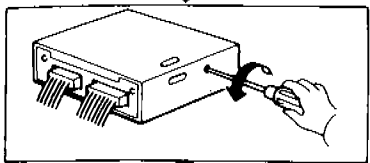
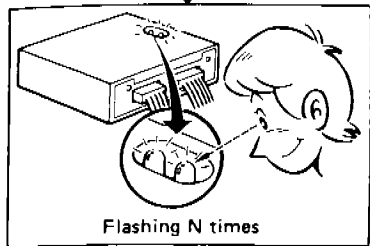
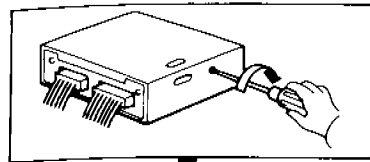

Mode N

SEF872D

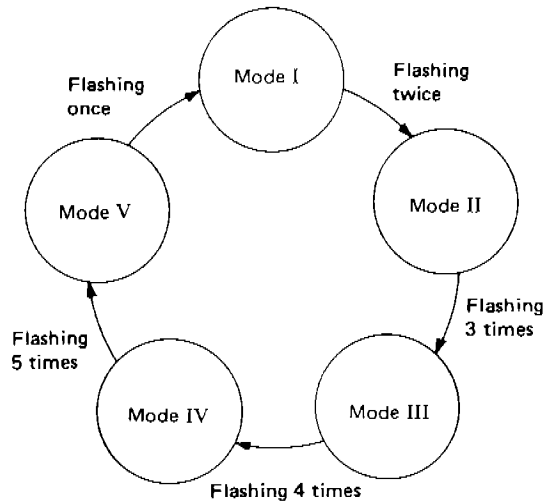

SEF989D

When the ignition switch is turned off during diagnosis, in each mode, and then turned back on again after the power to the E.C.U. has dropped off completely, the diagnosis will automatically return to Mode I.

The stored memory would be lost if:

1. Battery terminal is disconnected.
2. After selecting Mode III, Mode IV is selected.

However, if the diagnostic mode selector is kept turned fully clockwise, it will continue to change in the order of Mode I → II → III → IV → V → I ... etc., and in this state the stored memory will not be erased.

Self-diagnosis — Description

The self-diagnosis is useful to diagnose malfunctions in major sensors and actuators of the E.C.C.S. system. There are 5 modes in the self-diagnosis system.

Mode I and Mode II apply only for model with catalyzer.

1. Mode I — Mixture ratio feedback control monitor A

- During closed loop condition:
The green inspection lamp turns ON when lean condition is detected and goes OFF by rich condition.
- During open loop condition:
The green inspection lamp remains ON or OFF.

2. Mode II — Mixture ratio feedback control monitor B

- The green inspection lamp function is the same as Mode I.
- During closed loop condition:
The red inspection lamp turns ON and OFF simultaneously with the green inspection lamp when the mixture ratio is controlled within the specified value.
 - During open loop condition:
The red inspection lamp remains ON or OFF.

3. Mode III — Self-diagnosis

This mode is the same as the former self-diagnosis in self-diagnosis mode.

4. Mode IV — Switches ON/OFF diagnosis

During this mode, the inspection lamps monitor the switch ON-OFF condition.

- Idle switch
- Ignition switch "START"
- Vehicle speed sensor

5. Mode V — Real-time diagnosis

The moment the malfunction is detected, the display will be presented immediately. That is, the condition at which the malfunction occurs can be found by observing the inspection lamps during driving test.

TROUBLE DIAGNOSES

Diagnostic Table (Cont'd)

SYMPTOM & CONDITION 25 Backfire – through the exhaust

| POSSIBLE CAUSES | | 1 | 2 | 3 | 4 |
|------------------------|-------------------------------|---|---|---|---|
| SPECIFICATIONS | Mixture ratio (too rich) | ○ | ○ | | |
| FUEL SYSTEM | Injectors (fuel leaks) | | ○ | | |
| IGNITION SYSTEM | (missing) | | | | ○ |
| INTAKE SYSTEM | Air cleaner element (clogged) | ○ | | | |
| CONTROL SYSTEM | Idle switch (remaining OFF) | | | ○ | |

SERVICE PROCEDURE

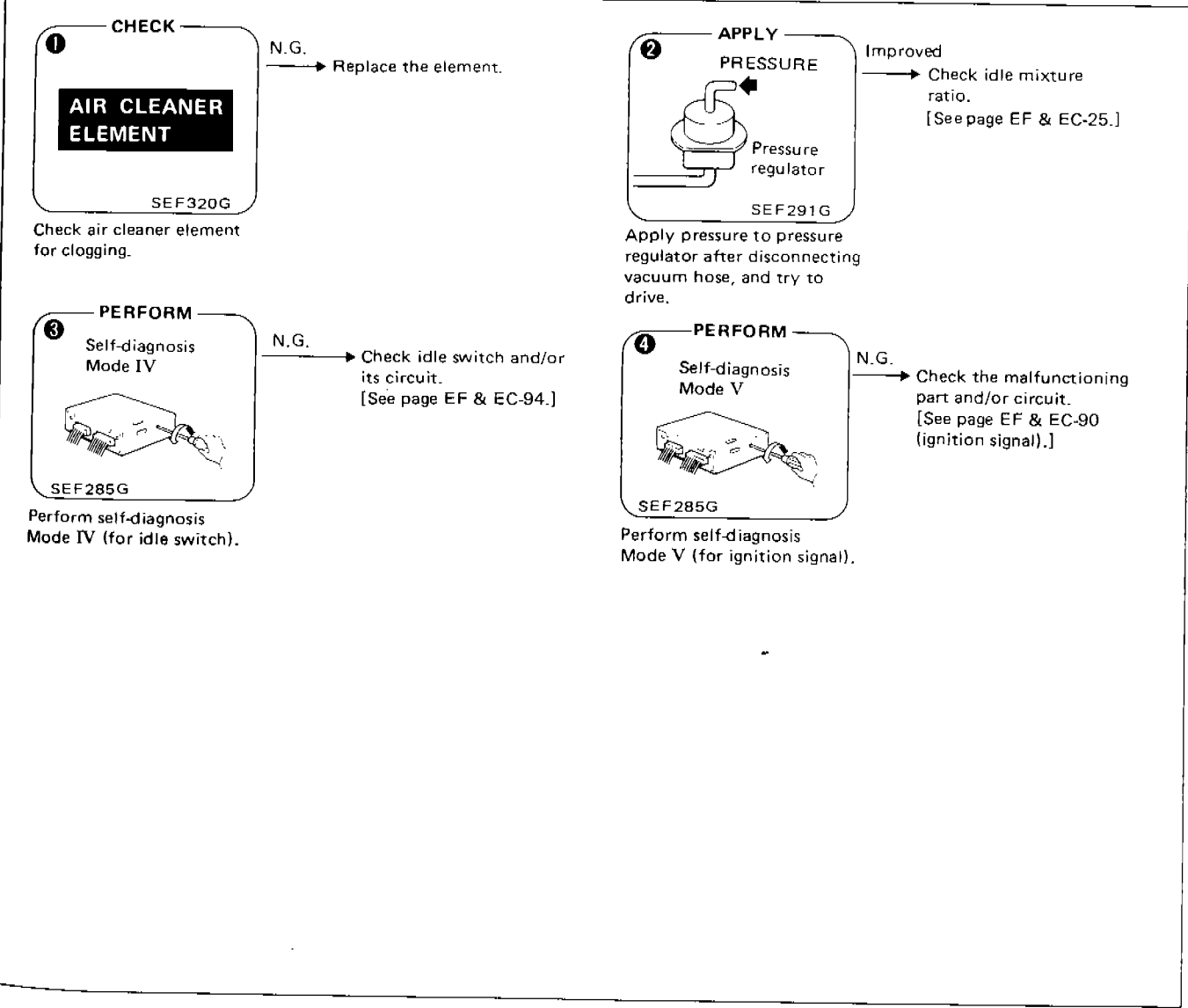

TROUBLE DIAGNOSES

Diagnostic Table (Cont'd)

SYMPTOM & CONDITION 24 Backfire -- through the intake

| POSSIBLE CAUSES | | 1 | 2 | 3 | 4 | 5 | 6 | 7 |
|-----------------------|---------------------------------------|---|---|---|---|---|---|---|
| SPECIFICATIONS | Mixture ratio (too lean) | ○ | | ○ | | ○ | ○ | |
| | Ignition timing (too retarded) | | ○ | | | | | |
| FUEL SYSTEM | Injectors (clogged) | | | | ○ | | | |
| INTAKE SYSTEM | Air duct (air leaks) | ○ | | | | | | |
| | Intake manifold (gaskets) (air leaks) | ○ | | | | | | |
| CONTROL SYSTEM | Air flow meter | | | | | | | ○ |
| | Exhaust gas sensor | | | | | ○ | ○ | |

SERVICE PROCEDURE

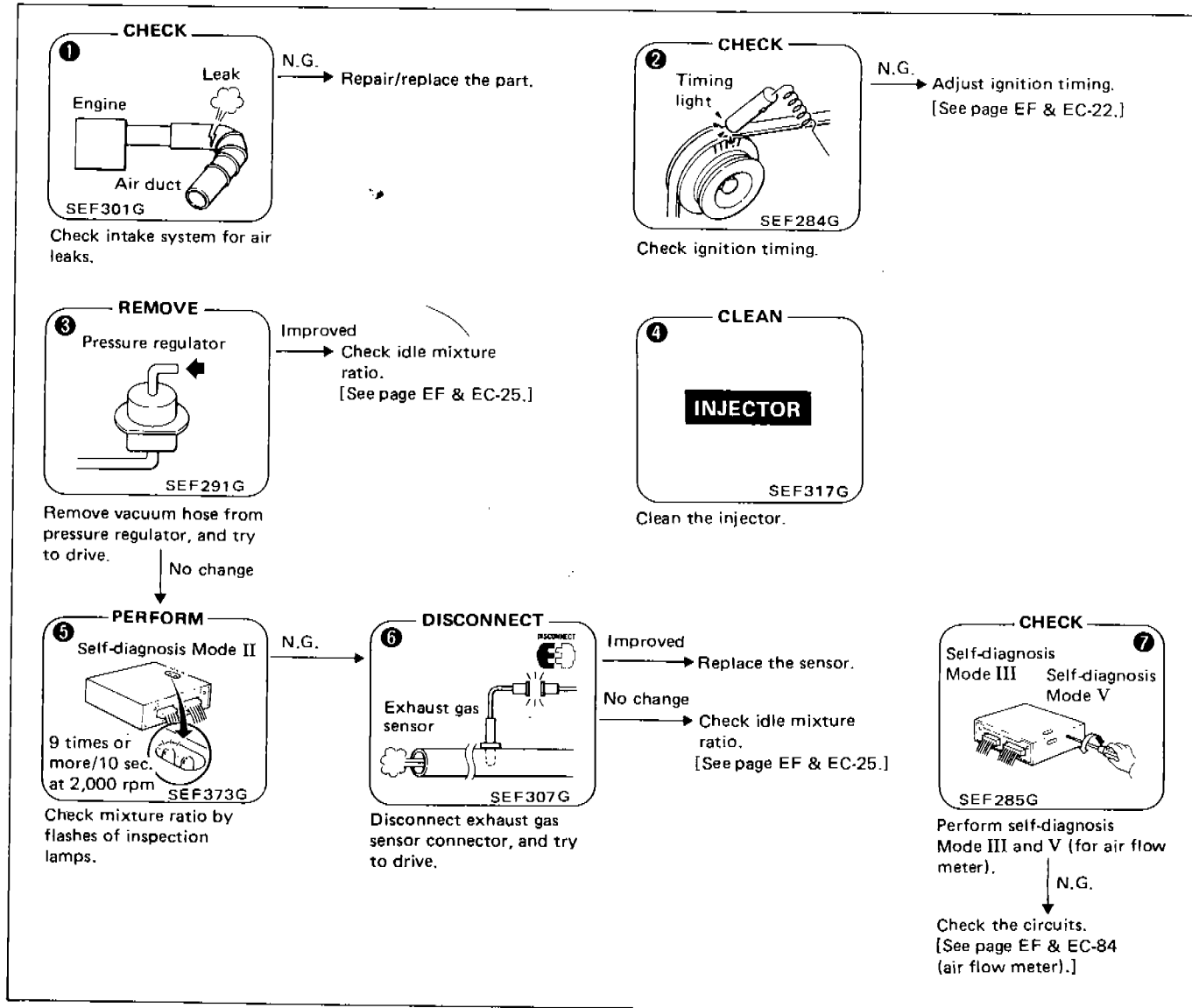

TROUBLE DIAGNOSES

Diagnostic Table (Cont'd)

SYMPTOM & CONDITION 23 Engine stall — while loading

| POSSIBLE CAUSES | | 1 | 2 | 3 | 4 | 5 |
|-----------------|-----------------------------------|---|---|---|---|---|
| SPECIFICATIONS | Ignition timing | | ○ | | | |
| | Idle speed (too low) | ○ | | | | |
| INTAKE SYSTEM | A.A.C. valve | ○ | | ○ | | |
| | F.I.C.D. solenoid (remaining OFF) | ○ | | | ○ | |
| CONTROL SYSTEM | Idle switch (remaining OFF) | ○ | | | | ○ |

SERVICE PROCEDURE

1 MEASURE

Tachometer

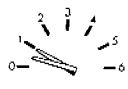

SEF316G

Measure idle speed.

N.G. → Adjust idle speed.
[See page EF & EC-25.]

2 CHECK

Timing light

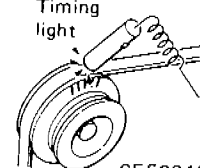

SEF284G

Check ignition timing.

N.G. → Adjust ignition timing.
[See page EF & EC-22.]

3 CHECK

Check A.A.C. valve and/or its circuit.
[See page EF & EC-106.]

4 CHECK

F.I.C.D. solenoid

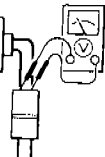

SEF981F

Check terminal voltage of F.I.C.D. solenoid.

→ Check the part and/or circuit.
[See HA section.]

5 PERFORM

Self-diagnosis Mode IV

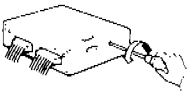

SEF285G

Perform self-diagnosis Mode IV (for idle switch).

N.G. → Check the idle switch circuit.
[See page EF & EC-94.]

TROUBLE DIAGNOSES

Diagnostic Table (Cont'd)

SYMPTOM & CONDITION 22 Engine stall – while decelerating/just after stopping

| POSSIBLE CAUSES | | 1 | 2 | 3 | 4 | 5 | 6 |
|-----------------|-----------------------------|---|---|---|---|---|---|
| SPECIFICATIONS | Mixture ratio | | | | | ○ | ○ |
| | Ignition sparks (missing) | ○ | | | | | |
| | Idle speed (too low) | | | ○ | | | |
| IGNITION SYSTEM | (missing) | ○ | ○ | | | | |
| INTAKE SYSTEM | A.A.C. valve | | | ○ | ○ | | |
| CONTROL SYSTEM | Exhaust gas sensor | | | | | ○ | ○ |
| | Crank angle sensor | | ○ | | | | |
| | Idle switch (remaining OFF) | | | ○ | | | |

SERVICE PROCEDURE

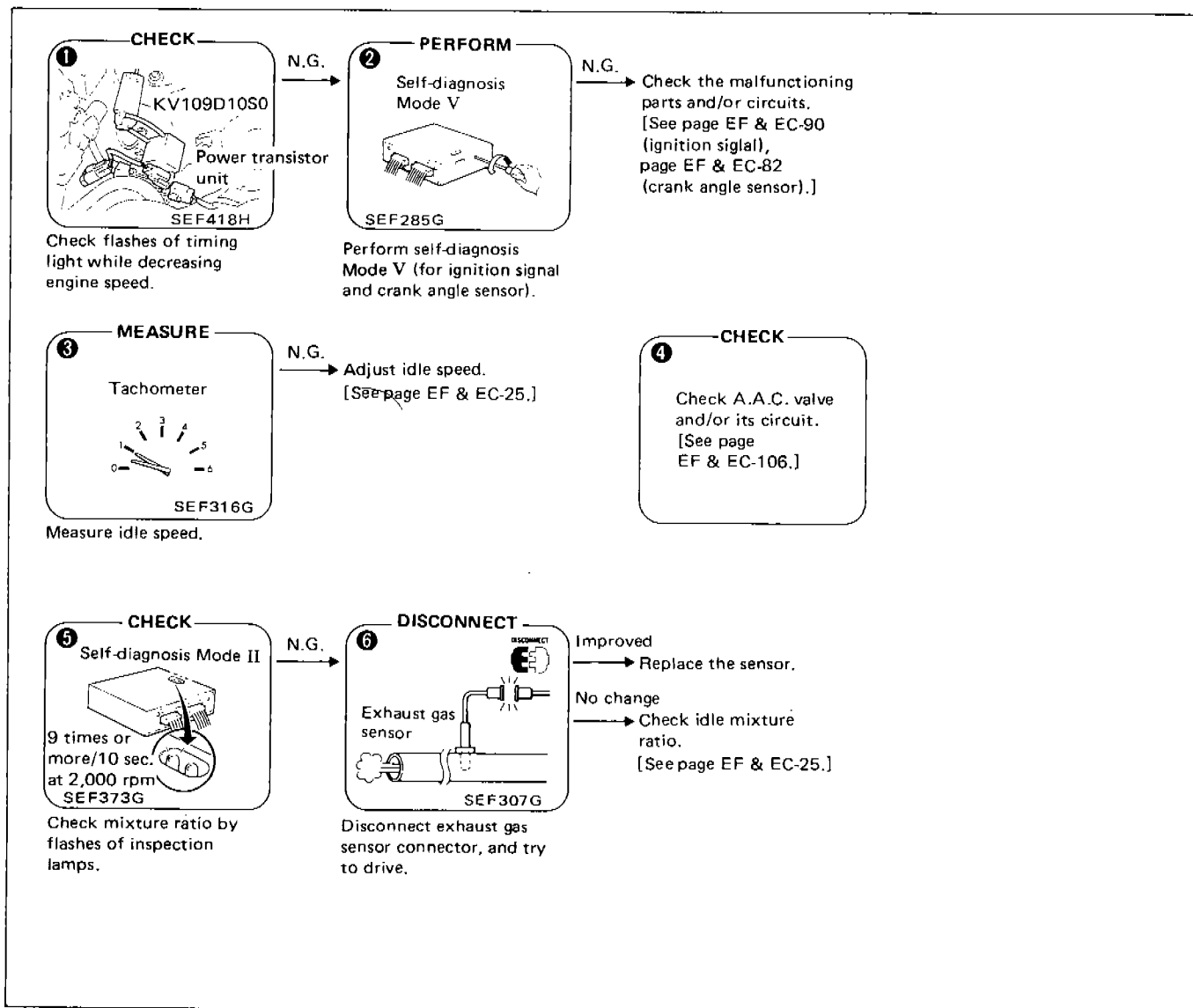

TROUBLE DIAGNOSES

Diagnostic Table (Cont'd)

SYMPTOM & CONDITION 21 Engine stall – while cruising

| POSSIBLE CAUSES | | 1 | 2 | 3 | 4 | 5 |
|-----------------|---------------------------------|---|---|---|---|---|
| SPECIFICATIONS | Mixture ratio | | | ○ | ○ | |
| | Ignition sparks (weak, missing) | ○ | ○ | | | |
| CONTROL SYSTEM | Crank angle sensor | | | | | ○ |
| | Air flow meter | | | | | ○ |
| | Exhaust gas sensor | | | ○ | ○ | |

SERVICE PROCEDURE

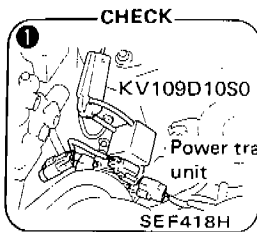

N.G. → Check ignition signal circuit.
[See page EF & EC-90.]

Check flashes of timing light for weakness at constant engine rev. (1,000 to 2,000 rpm).

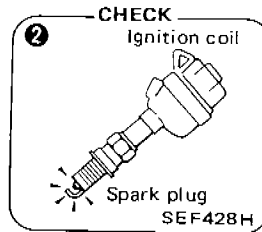

Remove spark plugs and check their ignition sparks.

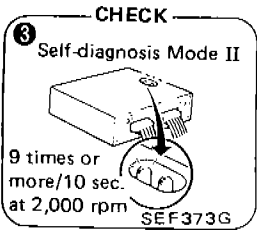

N.G. →

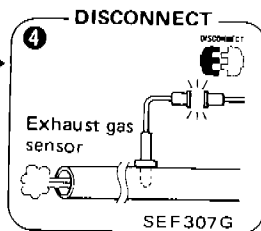

Improved → Replace the sensor.
No change → Check idle mixture ratio.
[See page EF & EC-25.]

Disconnect exhaust gas sensor connector, and try to drive.

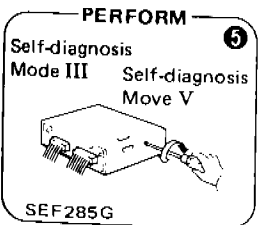

N.G. →

Check the circuits.
[See page EF & EC-82 (crank angle sensor), page EF & EC-84 (air flow meter).]

Perform self-diagnosis Mode III and V (for air flow meter and crank angle sensor).

TROUBLE DIAGNOSES

Diagnostic Table (Cont'd)

SYMPTOM & CONDITION 20 Engine stall – while accelerating

| POSSIBLE CAUSES | | 1 | 2 | 3 | 4 | 5 | 6 |
|-----------------|---------------------------------|---|---|---|---|---|---|
| SPECIFICATIONS | Mixture ratio | | | | ○ | ○ | |
| | Ignition sparks (weak, missing) | ○ | ○ | | | | |
| | Compression pressure (low) | | | ○ | | | |
| CONTROL SYSTEM | Crank angle sensor | ○ | | | | | ○ |
| | Air flow meter | | | | | | ○ |
| | Exhaust gas sensor | | | | ○ | ○ | |

SERVICE PROCEDURE

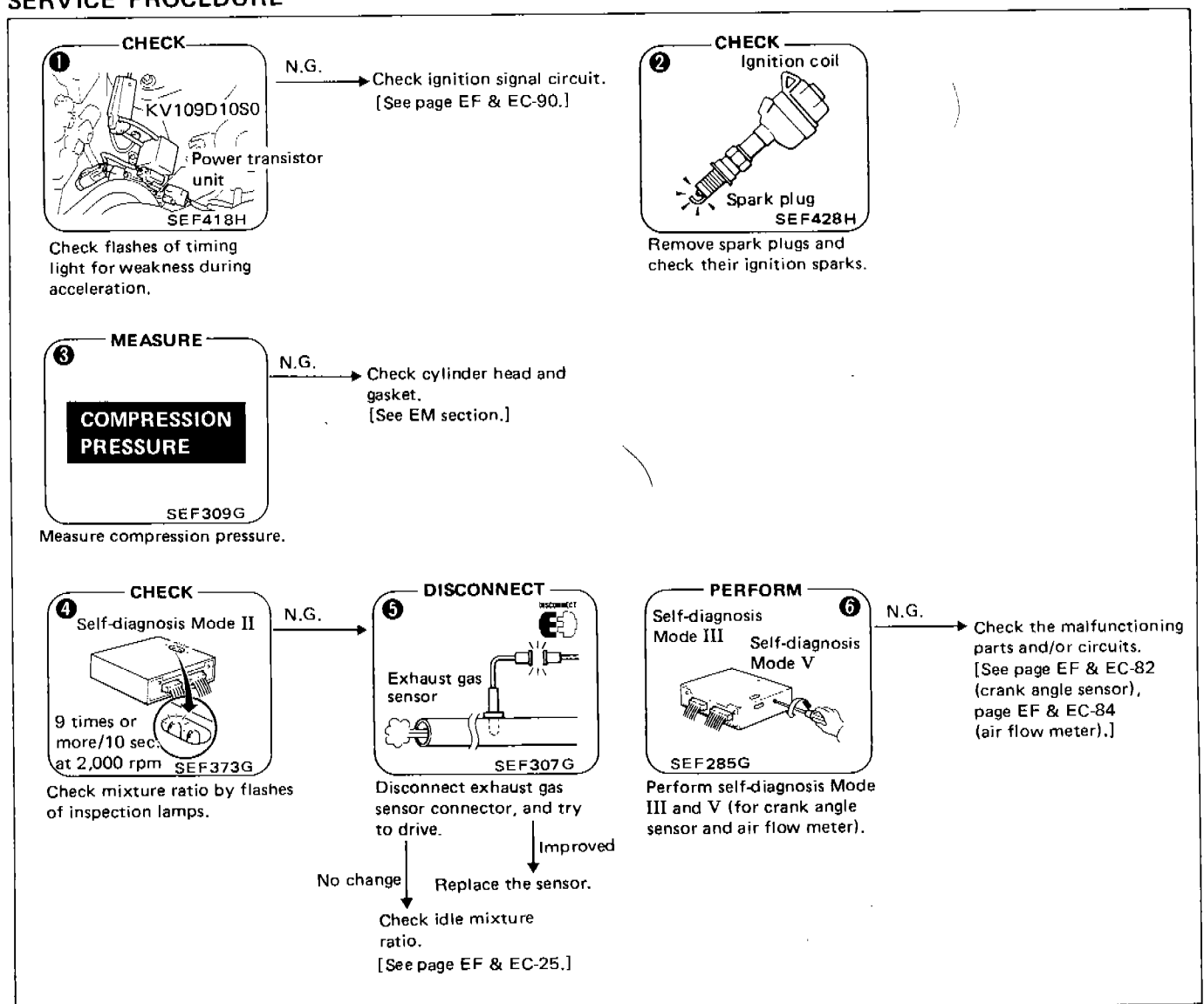

TROUBLE DIAGNOSES

Diagnostic Table (Cont'd)

SYMPTOM & CONDITION 19 Engine stall – while idling

| POSSIBLE CAUSES | | 1 | 2 | 3 | 4 | 5 | 6 | 7 | 8 | 9 |
|-----------------|-------------------------------------------|---|---|---|---|---|---|---|---|---|
| SPECIFICATIONS | Mixture ratio (too rich/too lean) | ○ | ○ | | | | | | | |
| | Fuel pressure (low) | ○ | ○ | | | | | | | |
| | Ignition sparks (weak, missing) | | | | ○ | | | | | |
| | Idle speed (low) | | | ○ | | | | | | |
| FUEL SYSTEM | Fuel line (clogged) | | ○ | | | | | | | |
| IGNITION SYSTEM | Spark plugs (wet with fuel, improper gap) | | | | | ○ | ○ | | | |
| INTAKE SYSTEM | A.A.C. valve | | | ○ | | | | ○ | | |
| | F.I.C.D. solenoid (improper operation) | | | ○ | | | | | ○ | |
| CONTROL SYSTEM | Idle switch (remaining OFF) | | | | | | | | | ○ |
| | Neutral switch (remaining OFF) | | | ○ | | | | | | |

SERVICE PROCEDURE

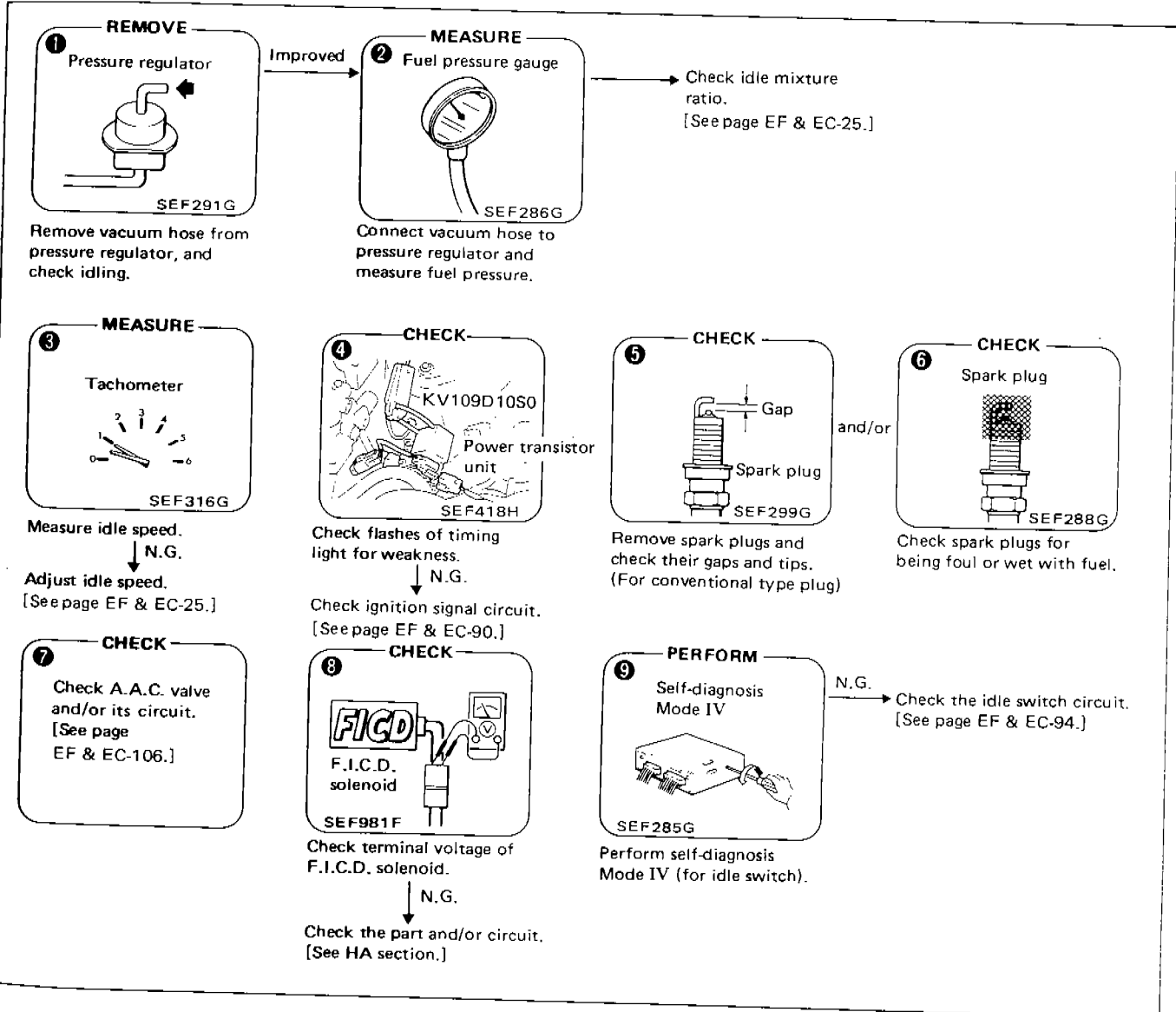

TROUBLE DIAGNOSES

Diagnostic Table (Cont'd)

SYMPTOM & CONDITION 18 Engine stall — during start-up

| POSSIBLE CAUSES | | 1 | 2 | 3 | 4 | 5 | 6 | 7 | 8 |
|-----------------|-------------------------------------------|---|---|---|---|---|---|---|---|
| SPECIFICATIONS | Mixture ratio (too rich/too lean) | | | | | | ○ | ○ | ○ |
| | Ignition sparks (weak) | | | ○ | | | | | |
| | Ignition timing | ○ | | | | | | | |
| | Compression pressure (too low) | | | | | ○ | | | |
| FUEL SYSTEM | Canister (too much evaporation to intake) | | | | | | ○ | | |
| IGNITION SYSTEM | Spark plugs (wet with fuel, improper gap) | | | | ○ | | | | |
| INTAKE SYSTEM | Throttle valve (not open enough) | | ○ | | | | | | |
| CONTROL SYSTEM | Exhaust gas sensor | | | | | | | | ○ |

SERVICE PROCEDURE

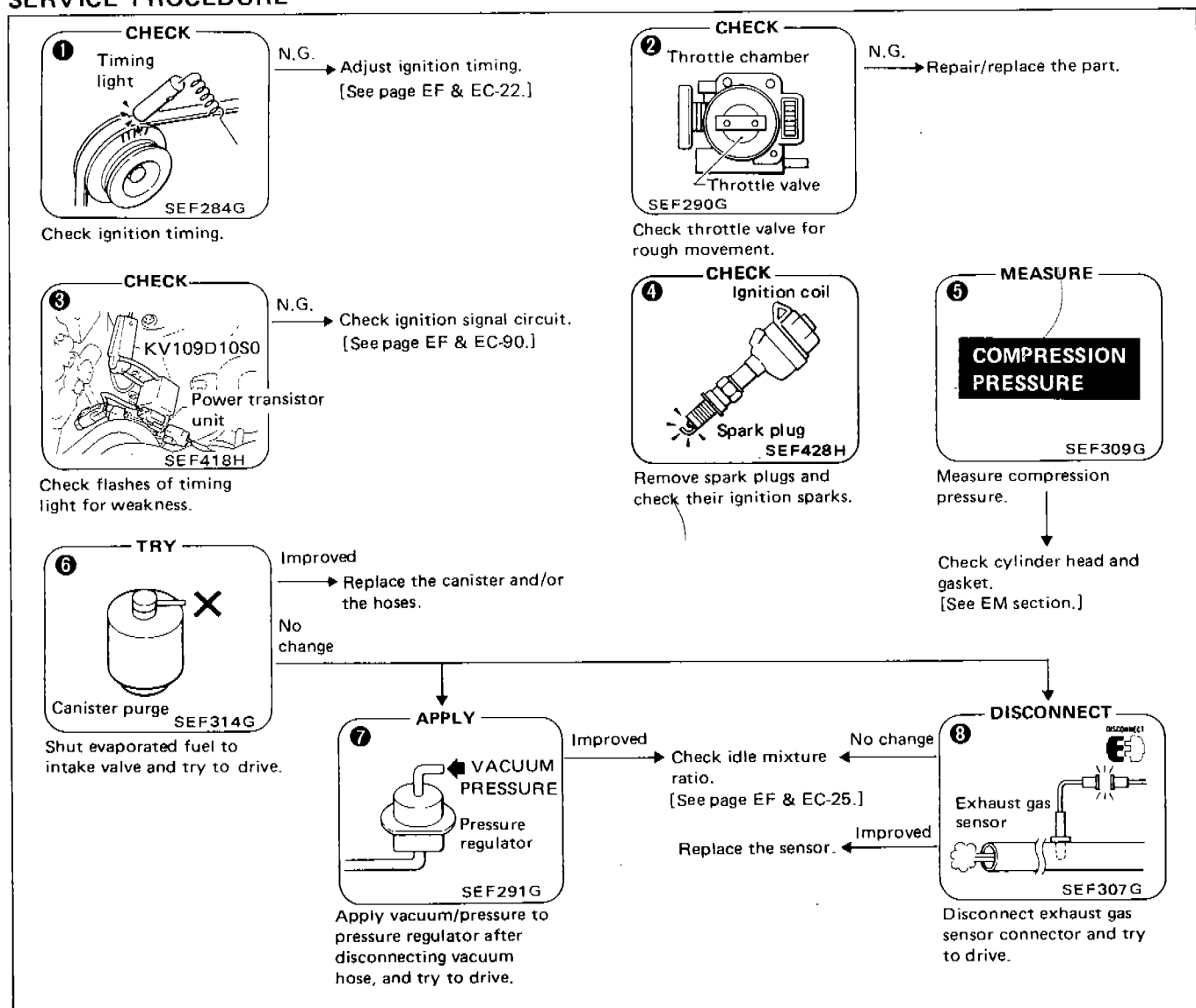

TROUBLE DIAGNOSES

Diagnostic Table (Cont'd)

SYMPTOM & CONDITION 17 **Poor driveability – detonation**

| POSSIBLE CAUSES | | 1 | 2 | 3 | 4 | 5 |
|-----------------|------------------------------------------|---|---|---|---|---|
| SPECIFICATIONS | Mixture ratio (too lean) | | | ○ | ○ | |
| | Fuel pressure (low) | | | ○ | | |
| | Ignition timing (too advanced) | | ○ | | | |
| FUEL SYSTEM | Fuel filter (clogged) | | | | ○ | |
| | Fuel line (clogged) | | | | ○ | |
| | Injectors (clogged) | | | | ○ | |
| CONTROL SYSTEM | Crank angle sensor (improper 1°-signals) | | | | | ○ |
| | Air flow meter | | | | | ○ |
| | Engine temperature sensor | | | | | ○ |
| OTHERS | Engine coolant temperature (too high) | ○ | | | | |
| | Fuel (low octane rating, poor quality) | | | | | |

SERVICE PROCEDURE

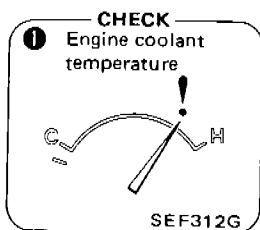

Too high → Check cooling system.
[See LC section.]

Check engine coolant temperature.

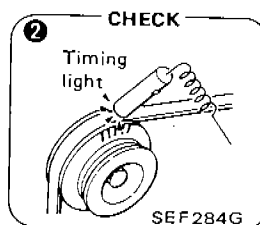

N.G. → Adjust ignition timing.
[See page EF & EC-22.]

Check ignition timing.

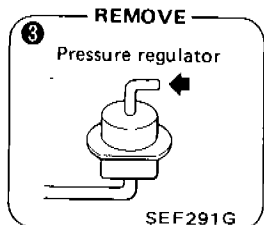

Remove vacuum hose from pressure regulator, and try to drive.

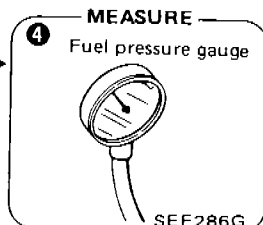

Connect vacuum hose to pressure regulator, and measure fuel pressure while driving.

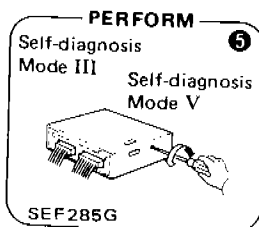

Perform self-diagnosis Mode III and V (for crank angle sensor, air flow meter and engine temp. sensor).

N.G. → Check the malfunctioning parts.
[See page EF & EC-82 (crank angle sensor), page EF & EC-84 (air flow meter), page EF & EC-86 (engine temp. sensor).]

TROUBLE DIAGNOSES

Diagnostic Table (Cont'd)

SYMPTOM & CONDITION 16 Poor driveability — lack of power

| POSSIBLE CAUSES | | 1 | 2 | 3 | 4 | 5 | 6 | 7 | 8 | 9 |
|-----------------|----------------------------------|---|---|---|---|---|---|---|---|---|
| SPECIFICATIONS | Fuel pressure | | | | | | ○ | ○ | | |
| | Ignition timing | | ○ | | | | | | | |
| | Compression pressure (too low) | | | | | ○ | | | | |
| FUEL SYSTEM | Fuel pump (low fuel output) | | | | | | | ○ | | |
| | Fuel filter (clogged) | | | | | | | ○ | | |
| | Fuel line (clogged) | | | | | | | ○ | | |
| | Injectors (clogged) | | | | | | | ○ | | |
| IGNITION SYSTEM | Spark plugs (improper gap) | | | | ○ | | | | | |
| INTAKE SYSTEM | Air cleaner element (clogged) | ○ | | | | | | | | |
| | Throttle chamber (clogged) | | | ○ | | | | | | |
| | Throttle valve (not open enough) | | | ○ | | | | | | |
| CONTROL SYSTEM | Air flow meter | | | | | | | | ○ | |
| | Exhaust gas sensor | | | | | | | | | ○ |

SERVICE PROCEDURE

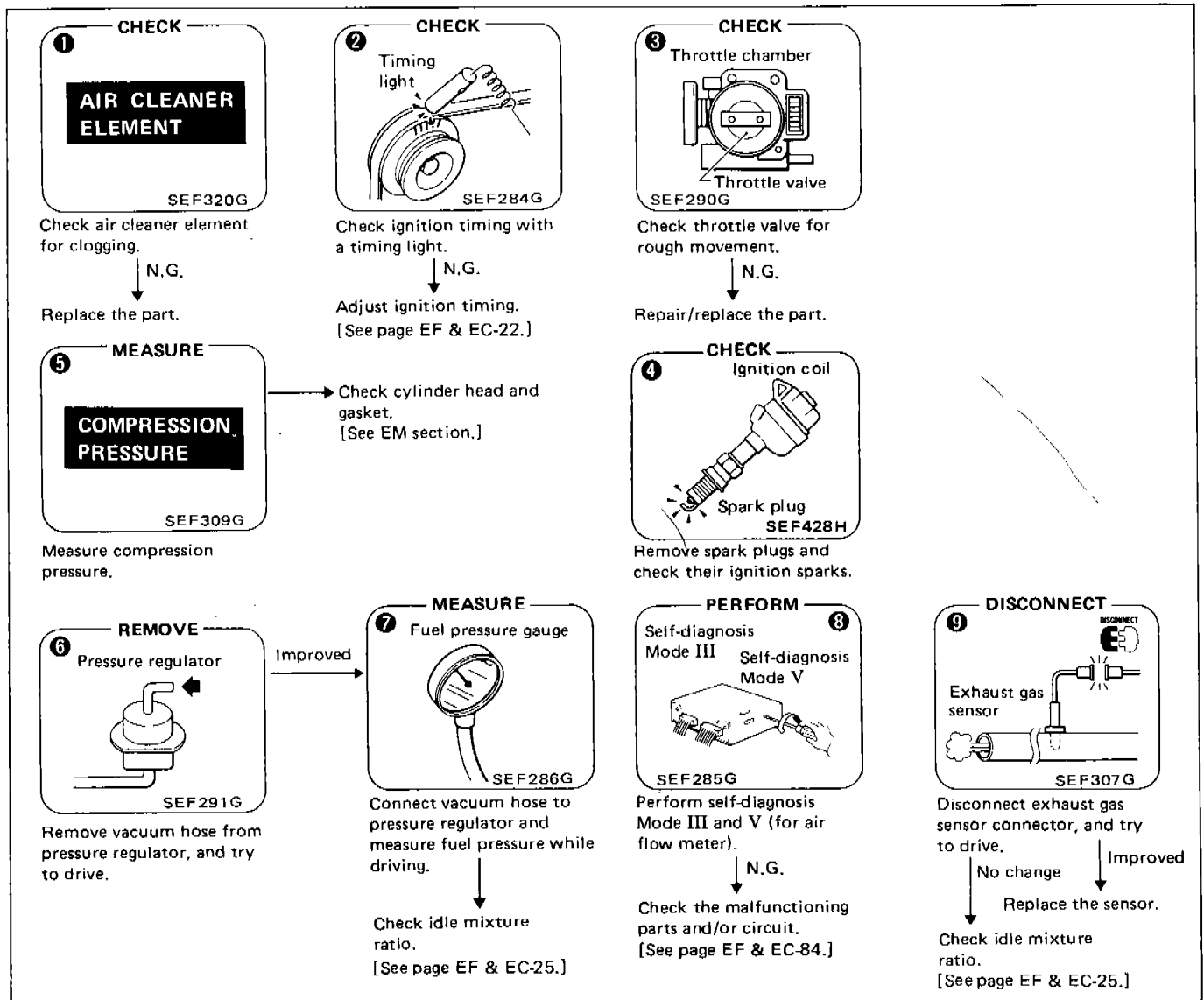

TROUBLE DIAGNOSES

Diagnostic Table (Cont'd)

SYMPTOM & CONDITION 15 Poor driveability – surge (while cruising)

| POSSIBLE CAUSES | | 1 | 2 | 3 | 4 | 5 | 6 | 7 |
|-----------------|--------------------------------------|---|---|---|---|---|---|---|
| SPECIFICATIONS | Mixture ratio (too lean) | ○ | | ○ | ○ | | | ○ |
| | Fuel pressure (low) | | | ○ | ○ | | | |
| | Ignition timing | | ○ | | | | | |
| IGNITION SYSTEM | (missing) | | | | | | ○ | |
| INTAKE SYSTEM | Air duct (leaks) | ○ | | | | | | |
| | Throttle chamber (air leaks) | ○ | | | | | | |
| | Intake manifold (gasket) (air leaks) | ○ | | | | | | |
| CONTROL SYSTEM | Crank angle sensor | | | | | | ○ | |
| | Air flow meter | | | | | | ○ | |
| | Exhaust gas sensor | | | | | | | ○ |
| | Idle switch | | | | | ○ | | |

SERVICE PROCEDURE

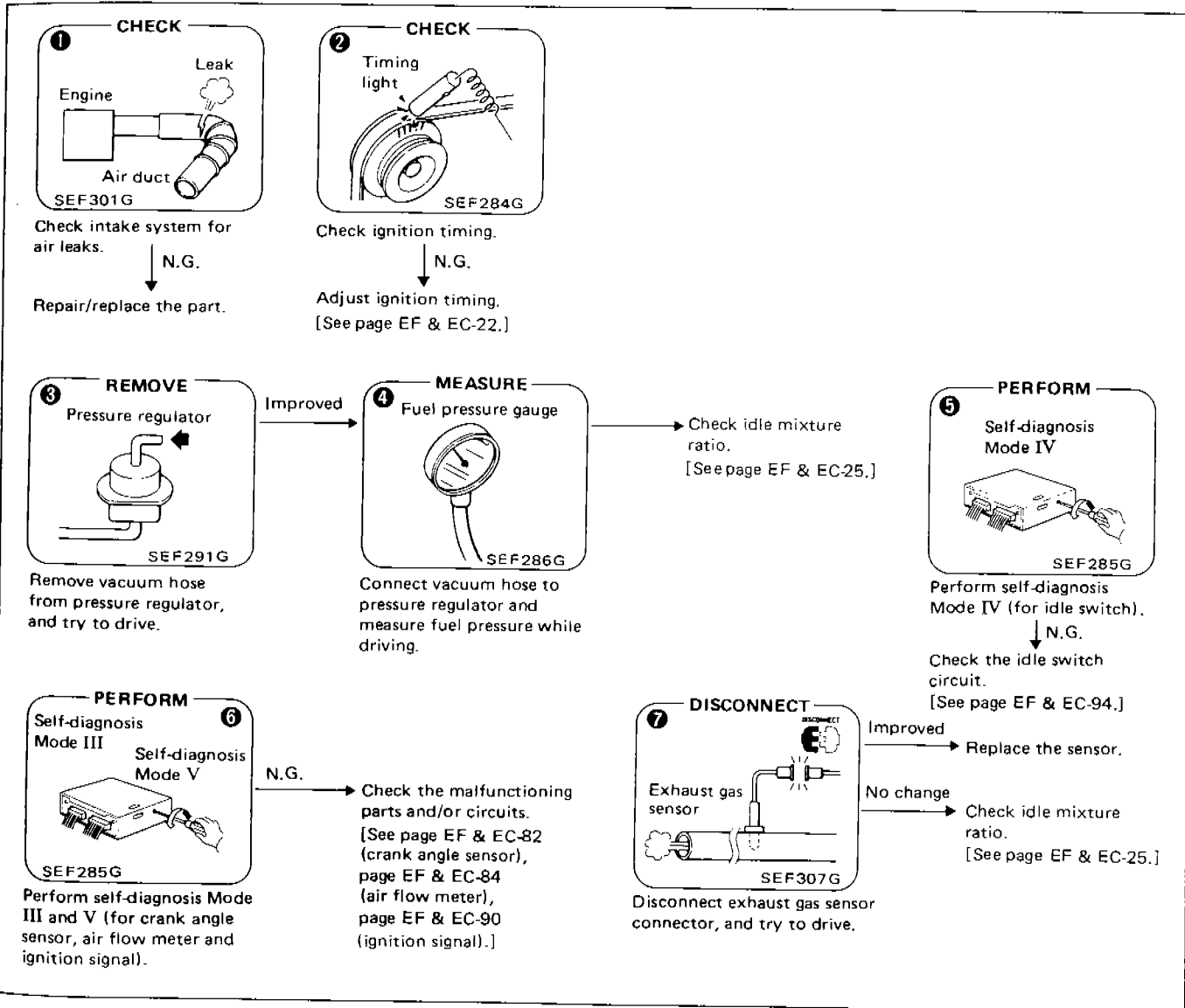

TROUBLE DIAGNOSES

Diagnostic Table (Cont'd)

SYMPTOM & CONDITION 14 Poor driveability – stumble (while accelerating)

| POSSIBLE CAUSES | | 1 | 2 | 3 | 4 | 5 | 6 | 7 | 8 |
|-----------------|--------------------------------------------|---|---|---|---|---|---|---|---|
| SPECIFICATIONS | Mixture ratio | | | ○ | | ○ | ○ | | ○ |
| | Fuel pressure | | | | | ○ | ○ | | |
| FUEL SYSTEM | Fuel filter (clogged) | | | | | | ○ | | |
| | Fuel line (clogged) | | | | | | ○ | | |
| | Injectors (clogged) | | | | | | ○ | | |
| IGNITION SYSTEM | Power transistor | ○ | ○ | | | | | | |
| | Ignition coil | ○ | ○ | | | | | | |
| | Spark plugs (ignition leaks, improper gap) | | ○ | | | | | | |
| INTAKE SYSTEM | Air duct (leaks) | | | ○ | | | | | |
| CONTROL SYSTEM | Crank angle sensor | ○ | | | | | | ○ | |
| | Air flow meter | | | | | | | ○ | |
| | Engine temperature sensor | ○ | | | | | | ○ | |
| | Exhaust gas sensor | | | | | | | | ○ |
| | Idle switch (remaining OFF) | | | | ○ | | | | |
| OTHERS | Fuel (poor quality) | | | | | | | | |

SERVICE PROCEDURE

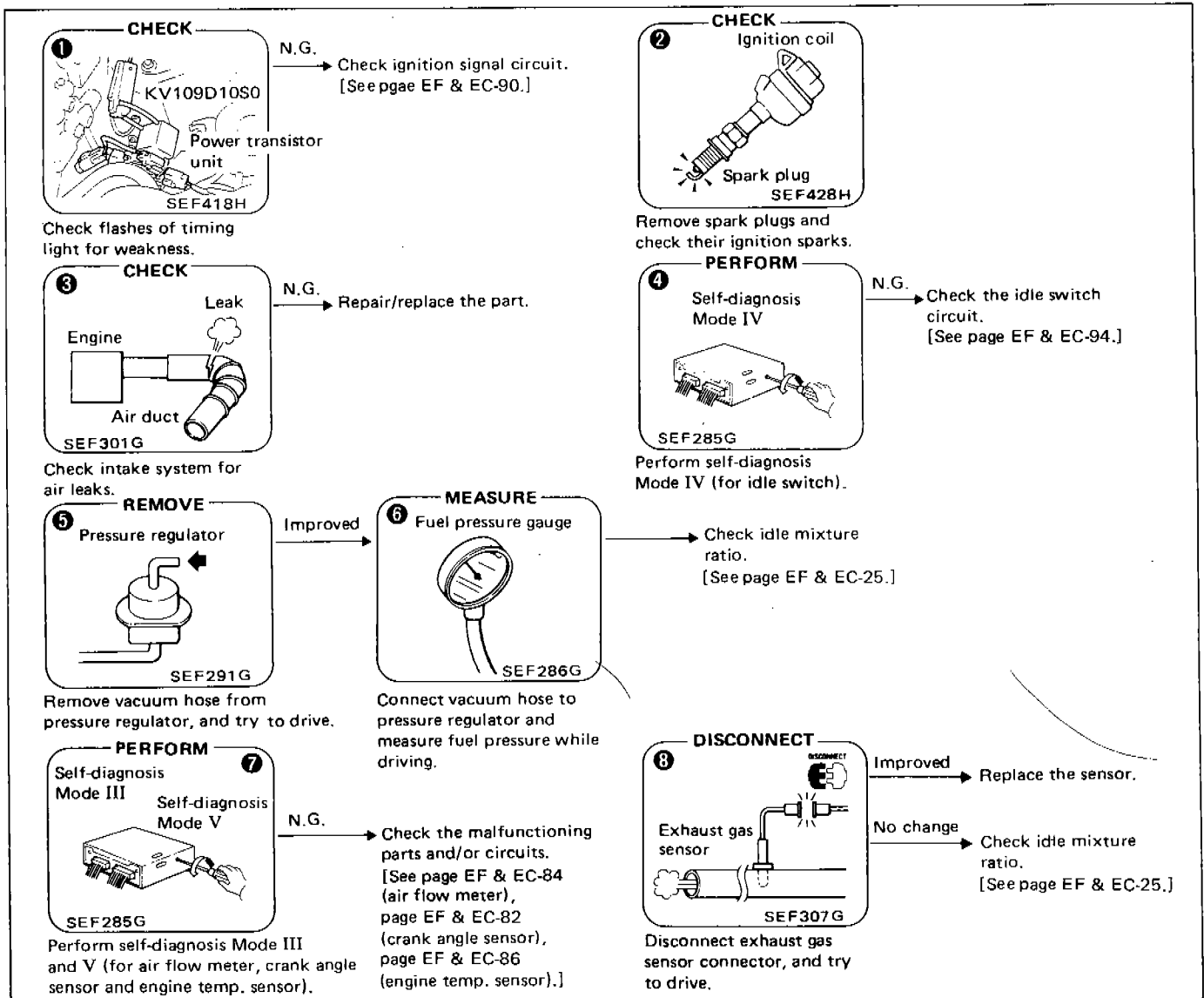

TROUBLE DIAGNOSES

Diagnostic Table (Cont'd)

SYMPTOM & CONDITION 13 Unstable idling – after warm-up

| POSSIBLE CAUSES | | 1 | 2 | 3 | 4 | 5 | 6 | 7 | 8 | 9 |
|-----------------|-------------------------------------|---|---|---|---|---|---|---|---|---|
| SPECIFICATIONS | Mixture ratio | ○ | ○ | ○ | ○ | | | | | |
| | Ignition sparks | | | | | ○ | ○ | | | |
| | Ignition timing | | | | | | | ○ | | |
| | Compression pressure | | | | | | | | ○ | |
| FUEL SYSTEM | Fuel line (clogged) | | | | | | | | | |
| | Canister (air leaks) | | | ○ | | | | | | |
| | Pressure regulator control solenoid | | | | ○ | | | | | |
| IGNITION SYSTEM | Power transistor | | | | | ○ | ○ | | | |
| | Ignition coil | | | | | ○ | ○ | | | |
| INTAKE SYSTEM | Blow-by hose (leaks) | ○ | | | | | | | | |
| | Air duct (leaks) | | ○ | | | | | | | |
| CONTROL SYSTEM | Idle switch | | | | | | | | | ○ |

SERVICE PROCEDURE

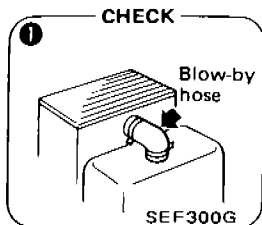

1 CHECK
Check blow-by hose for leaks.
↓ N.G.
Repair/replace the hose.

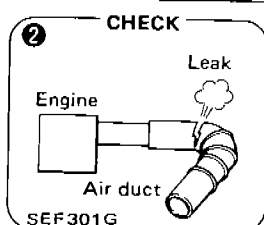

2 CHECK
Check intake system for air leaks.
↓ N.G.
Repair/replace the part.

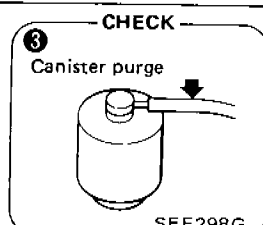

3 CHECK
Check purge line for leaks.
↓ N.G.
Repair/replace the hose.

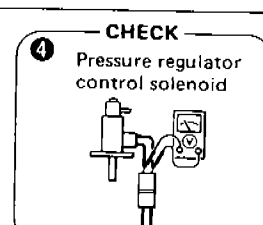

4 CHECK
Check terminal voltage of the solenoid while idling.
↓ N.G.
Check the solenoid circuit. [See page EF & EC-114.]

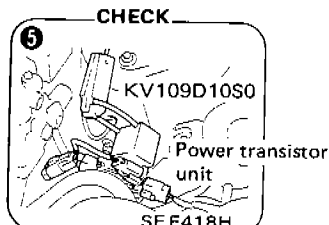

5 CHECK
Check flashes of timing light for weakness.
↓ N.G.
Check ignition signal circuit. [See page EF & EC-90.]

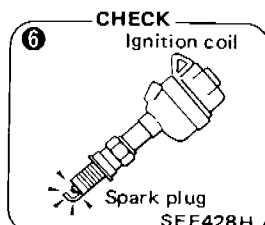

6 CHECK
Remove spark plugs and check their ignition sparks.

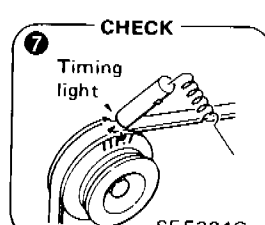

7 CHECK
Check ignition timing.
↓ N.G.
Adjust ignition timing. [See page EF & EC-22.]

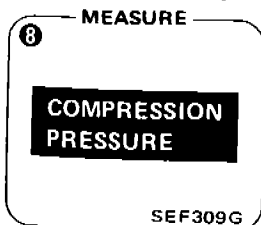

8 MEASURE
Measure compression pressure.
↓ N.G.
Check cylinder head and gasket. [See EM section.]

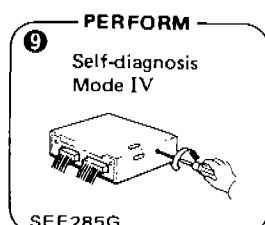

9 PERFORM
Perform self-diagnosis Mode IV (for idle switch).
↓ N.G.
Check the idle switch circuit. [See page EF & EC-94.]

TROUBLE DIAGNOSES

Diagnostic Table (Cont'd)

SYMPTOM & CONDITION 12 Unstable idling – before warm-up

| POSSIBLE CAUSES | | 1 | 2 | 3 | 4 | 5 | 6 |
|-----------------|---------------------------------|---|---|---|---|---|---|
| SPECIFICATIONS | Mixture ratio | | ○ | ○ | | | |
| | Ignition timing | ○ | | | | | |
| INTAKE SYSTEM | Air regulator (not open enough) | | ○ | | | | |
| | A.A.C. valve | | | | ○ | | |
| CONTROL SYSTEM | Engine temperature sensor | | | | | ○ | ○ |

SERVICE PROCEDURE

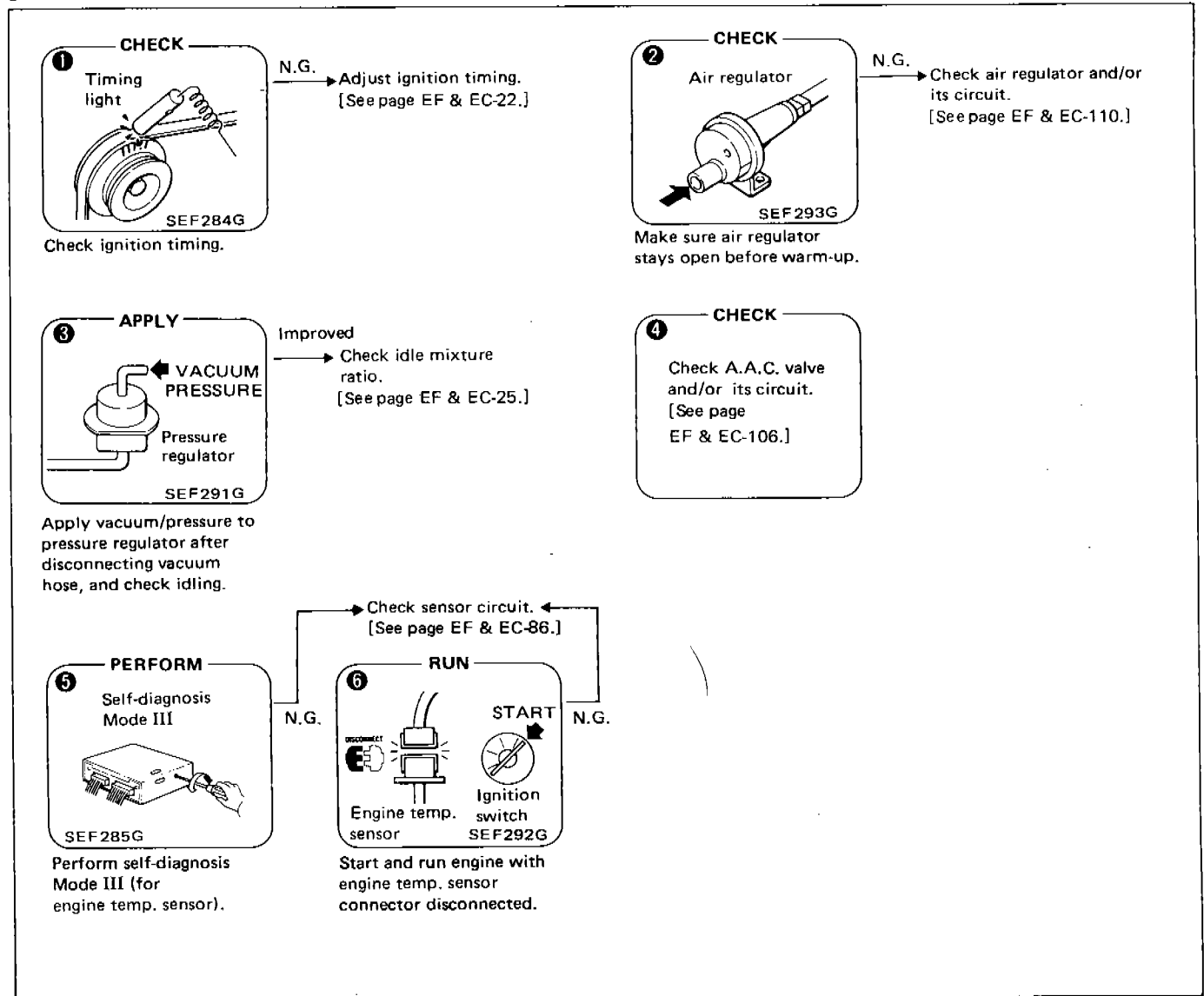

PRECAUTIONS

E.C.U.

- Do not disassemble E.C.C.S. control unit. (E.C.U.)
- Do not turn diagnosis mode selector forcibly.
- If a battery terminal is disconnected, the memory will return to the ROM value. The E.C.C.S. will now start to self-control at its initial value. Engine operation can vary slightly when the terminal is disconnected. However, this is not an indication of a problem. Do not replace parts because of a slight variation. (Model with catalyzer)
- Do not apply undue force to mounting bracket.
- Before connecting or disconnecting E.C.U. connector, make sure red and green L.E.D.s are off after turning ignition key off.
- Always install specified E.C.U. on car; otherwise, erroneous engine operation may result.
- Disconnect connector by pulling it (not the harness) straight out.

E.C.C.S. HARNESS HANDLING

- Securely connect E.C.C.S. harness connectors. A poor connection can cause extremely high voltage to develop in the coil and condenser, resulting in damage to ICs.
- Keep E.C.C.S. harness at least 10 cm (3.9 in) away from adjacent harnesses, to prevent an E.C.C.S. system malfunction due to receiving external noise, degraded operation of ICs, etc.
- Keep E.C.C.S. parts and harnesses dry.
- Before removing parts, turn off ignition switch and then disconnect battery ground cable.
- Before connecting connector, make sure all pins are straight.

E.C.C.S. PARTS HANDLING

- Handle air flow meter carefully to avoid damage.
- Do not disassemble air flow meter.
- Do not clean air flow meter with detergent.
- Do not shock or jar the crank angle sensor.

INJECTOR

- Do not disconnect injector harness connectors with engine running.
- Do not apply battery power directly to injectors; otherwise injectors will be damaged.

FUEL PUMP

- Do not operate fuel pump when there is no fuel in lines.
- Do not reuse fuel hose clamps.
- Tighten fuel hose clamps to the specified torque.

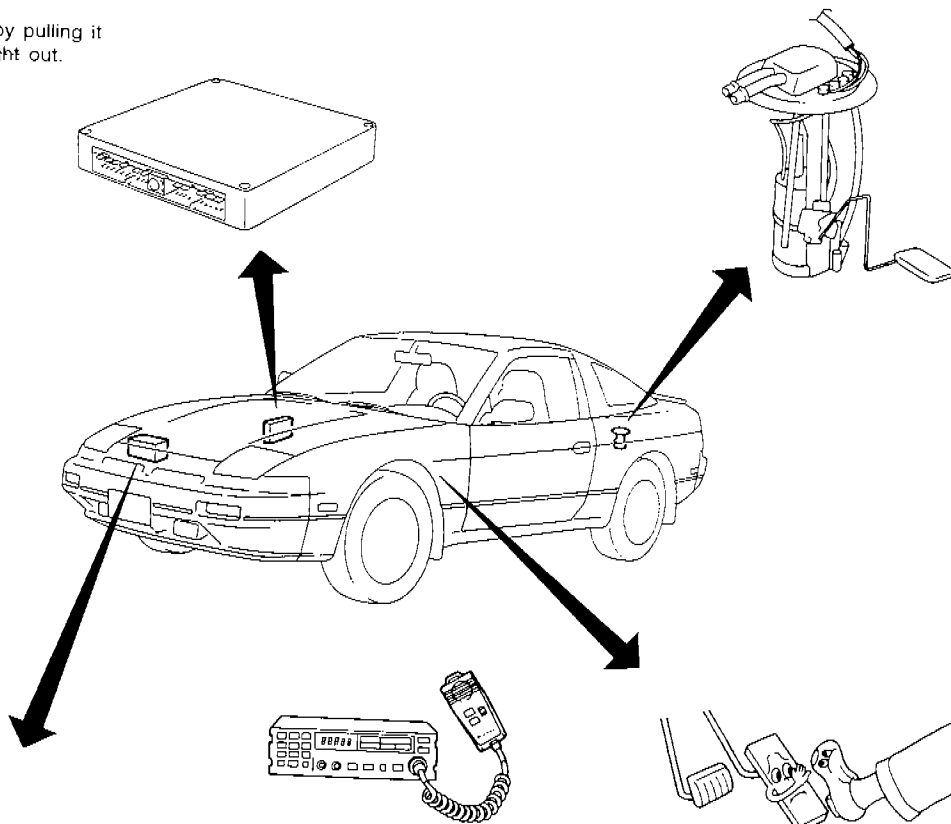

BATTERY

- Always use a 12 volt battery as power source.
- Do not disconnect battery cables while the engine is running.
- Do not reverse polarity of battery when connecting it. Otherwise, E.C.U. and/or injectors may be burned.

WIRELESS EQUIPMENT

- When installing a C.B. ham radio or a mobile phone, be sure to observe the following, as installation location may affect the electronic control systems.
 - 1) Keep antenna as far as possible away from electronic control units.
 - 2) Keep antenna feeder line more than 20 cm (7.9 in) away from harness of electronic controls. Do not let them run parallel for a long distance.
 - 3) Adjust antenna and feeder line so that standing-wave ratio can be kept smaller.
 - 4) Be sure to ground radio to vehicle body.

WHEN STARTING

- Do not depress accelerator pedal when starting.
- Immediately after starting, do not rev up engine unnecessarily.
- Do not rev up engine just prior to shutdown.

SEF398H

PREPARATION

SPECIAL SERVICE TOOLS

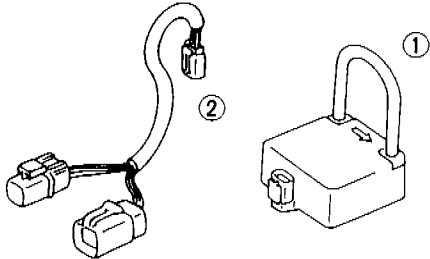
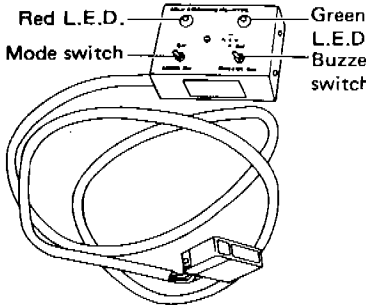
| Tool number Tool name | Description |
|-----------------------------------------------------------------------------------------------------------------------------------------|---------------------------------------------------------------------------------------------------------------------------------------------------------------------------------------------------------------------------------------------------------------------------------------------------------------------|
| KV109D10S0 Ignition timing adapter coil set ① KV109D0010 Ignition timing adapter coil ② KV109D0015 Adapter harness |  <p>Measuring ignition timing</p> <p>The diagram shows two components: a coil set (labeled 2) with a curved lead and a connector, and a rectangular box (labeled 1) with a handle and a connector.</p> |
| KV109D0020 Checker Box |  <p>Reading self-diagnosis indication</p> <p>The diagram shows a rectangular checker box with a mode switch, a red L.E.D., a green L.E.D., and a buzzer switch. A cable with a connector is attached to the bottom of the box.</p> |

TROUBLE DIAGNOSES

Diagnostic Procedure 5 (Cont'd)

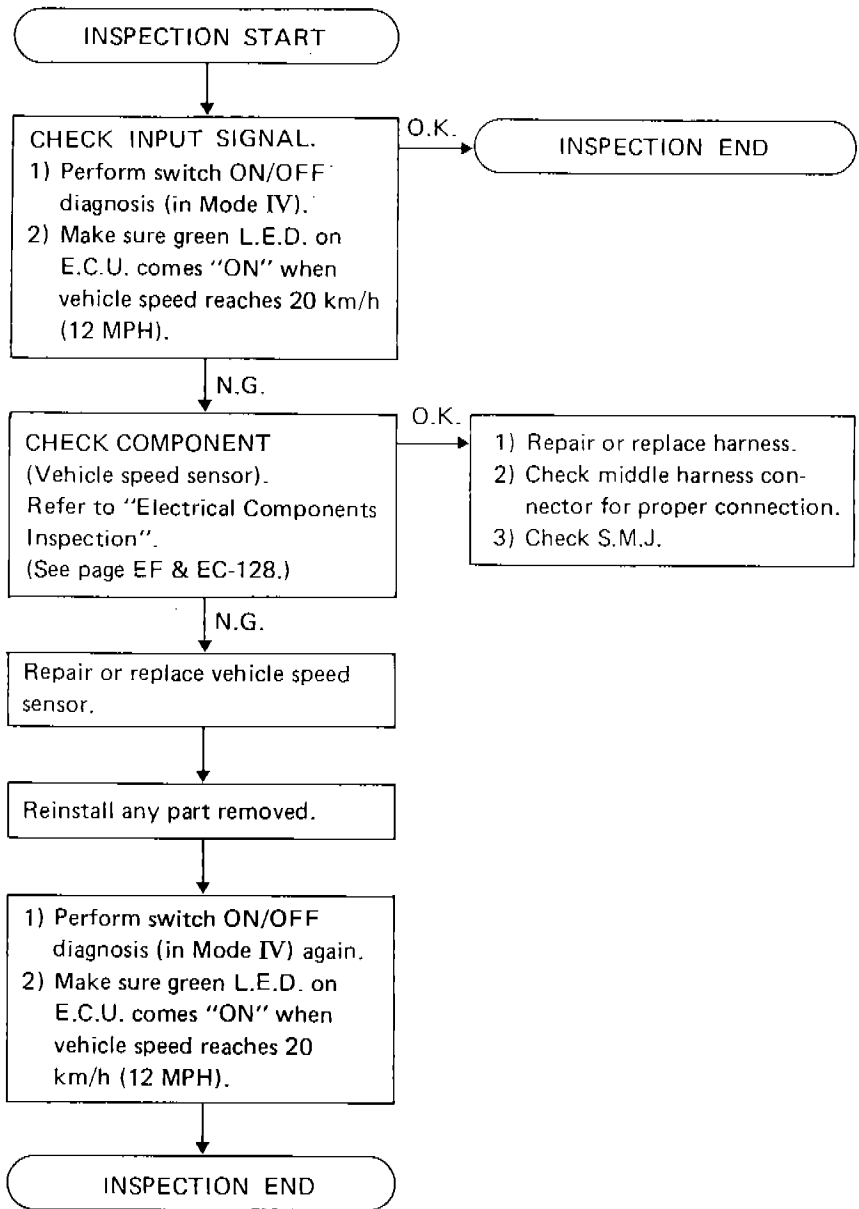
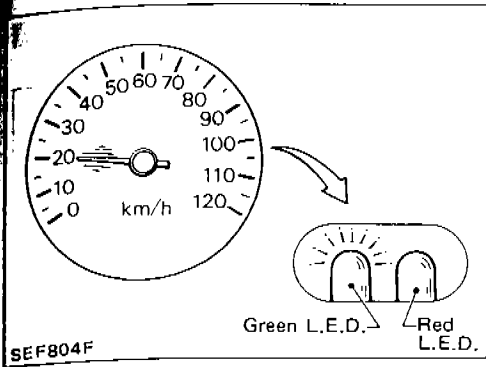

TROUBLE DIAGNOSES

Diagnostic Procedure 5

VEHICLE SPEED SENSOR

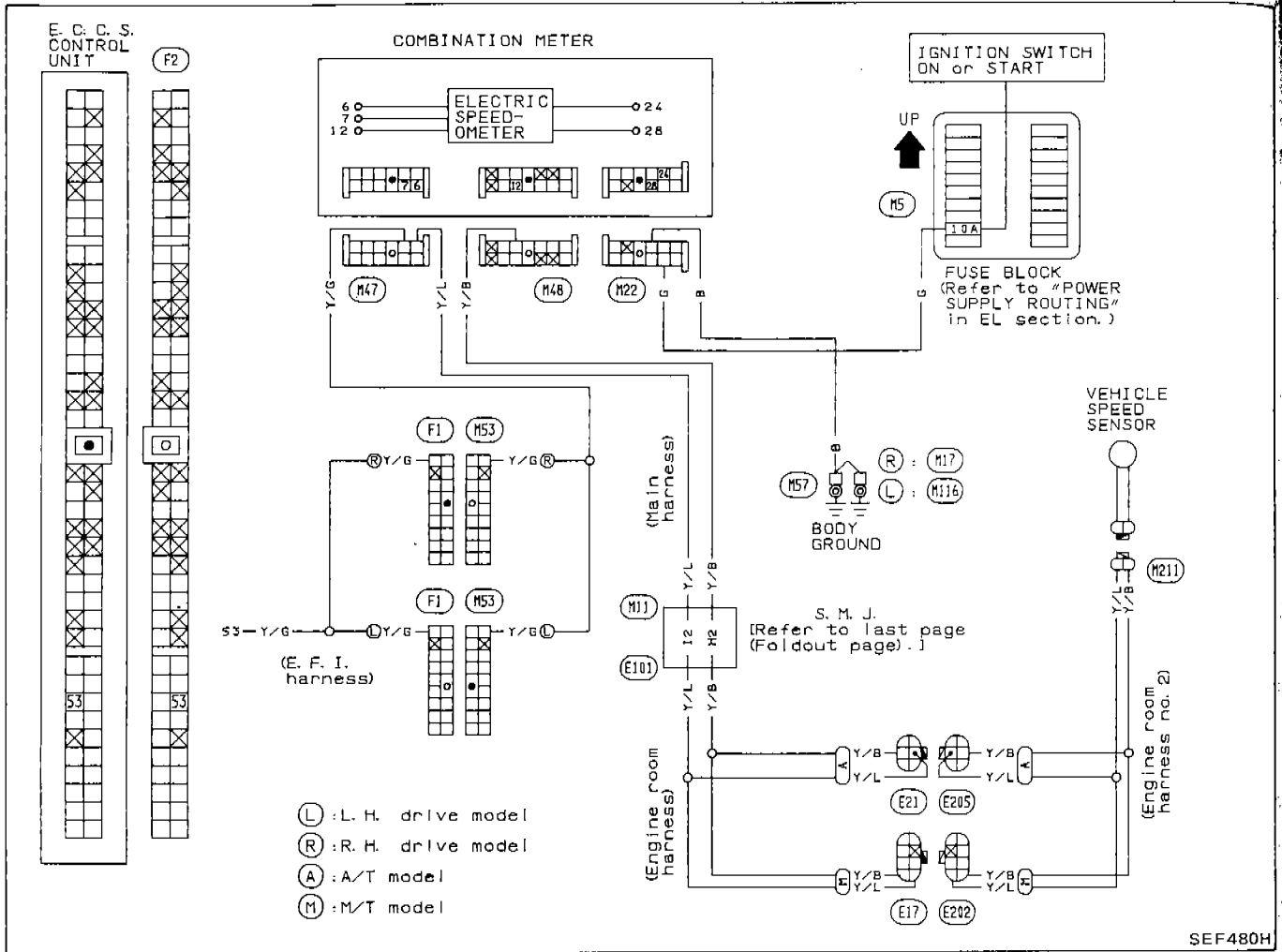

SEF480H

ENGINE MAINTENANCE

Checking Exhaust Gas Sensor

Checking procedure

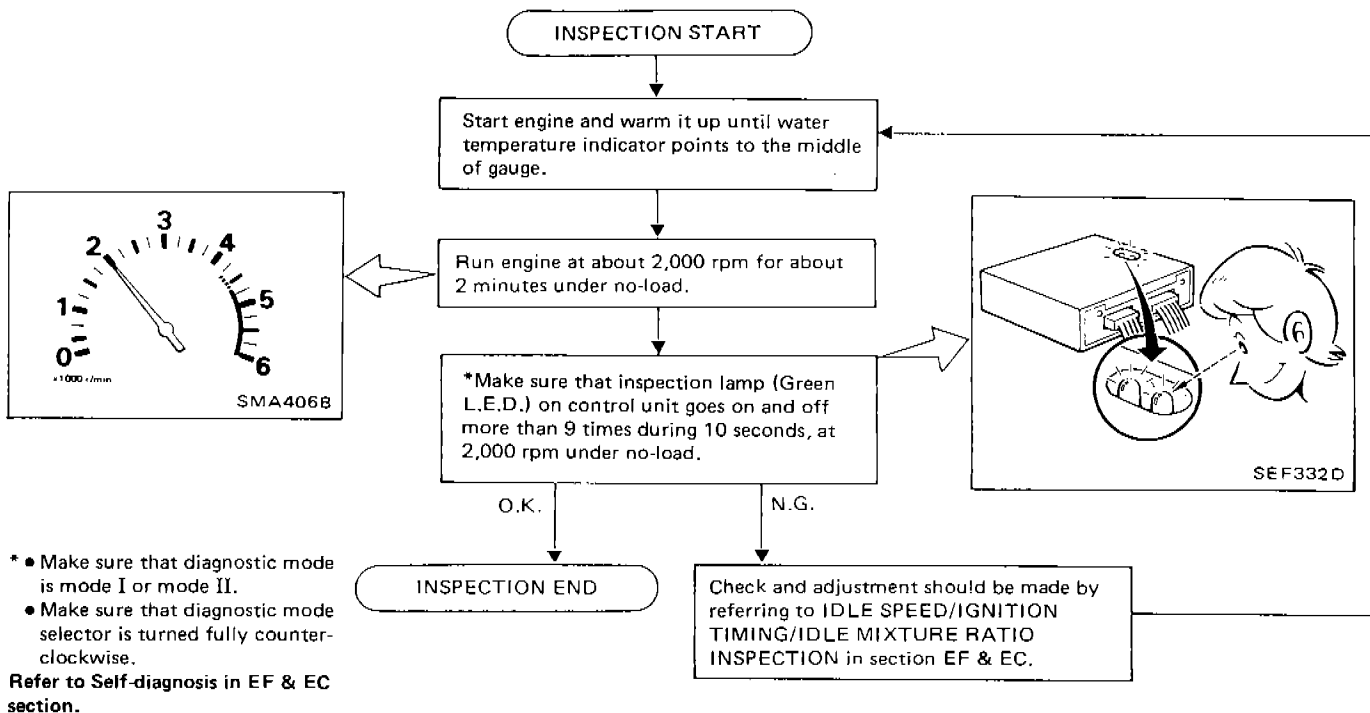

CHASSIS AND BODY MAINTENANCE

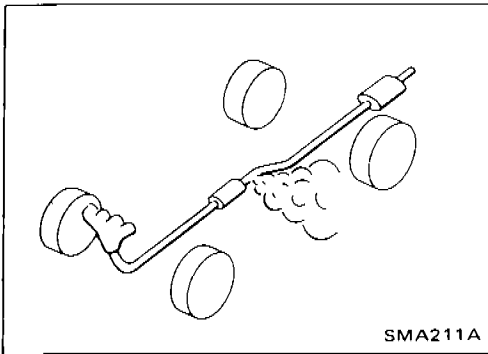

Checking Exhaust System

- Check exhaust pipes, muffler and mounting for improper attachment and for leaks, cracks, damage, loose connections, chafing and deterioration.

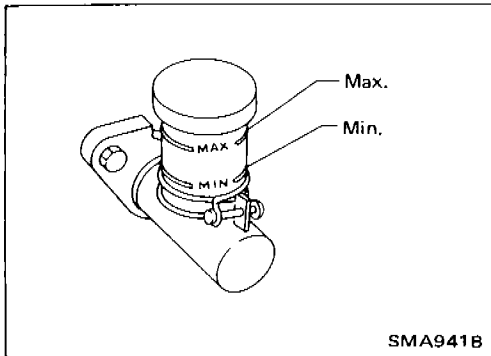

Checking Clutch Fluid Level and Leaks

- If fluid level is extremely low, check clutch system for leaks.

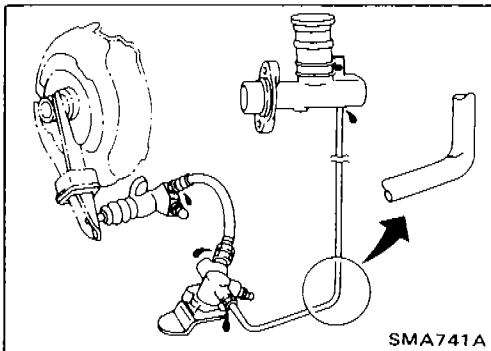

Checking Clutch System

HYDRAULIC TYPE

Check fluid lines and operating cylinder for improper attachment, cracks, damage, loose connections, chafing and deterioration.

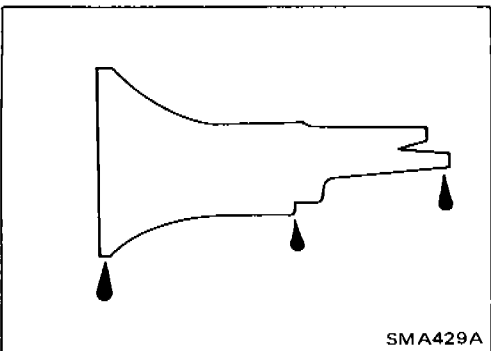

Checking M/T Oil

1. Check for oil leakage.

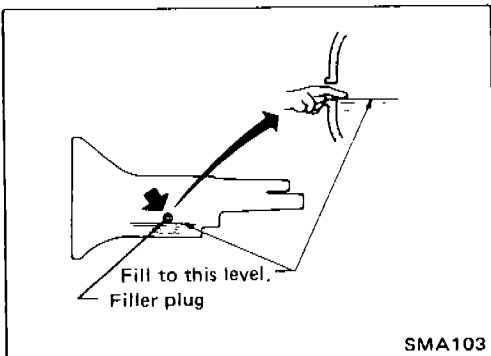

2. Check oil level.

Never start engine while checking oil level.

Filler plug:

⌚: 25 - 34 N·m (2.5 - 3.5 kg-m, 18 - 25 ft-lb)

FRONT SUSPENSION

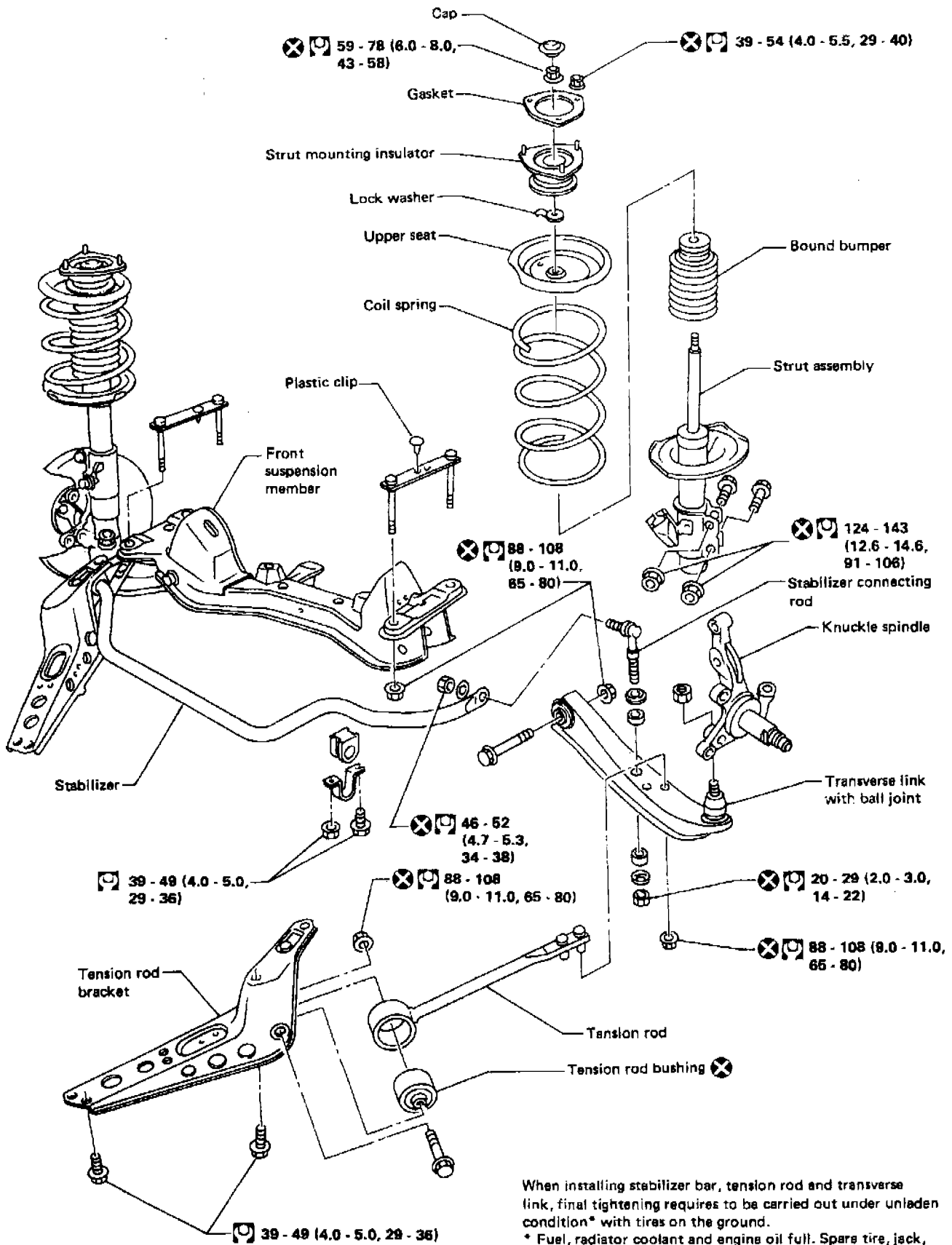

When installing stabilizer bar, tension rod and transverse link, final tightening requires to be carried out under unladen condition* with tires on the ground.

* Fuel, radiator coolant and engine oil full. Spare tire, jack, hand tools and mats in designated position.

: N-m (kg-m, ft-lb)

SFA560A



ENGINE AND EMISSION CONTROL OVERALL SYSTEM

Circuit Diagram

(For Wiring Diagram — see pull-out following page EL-108.)

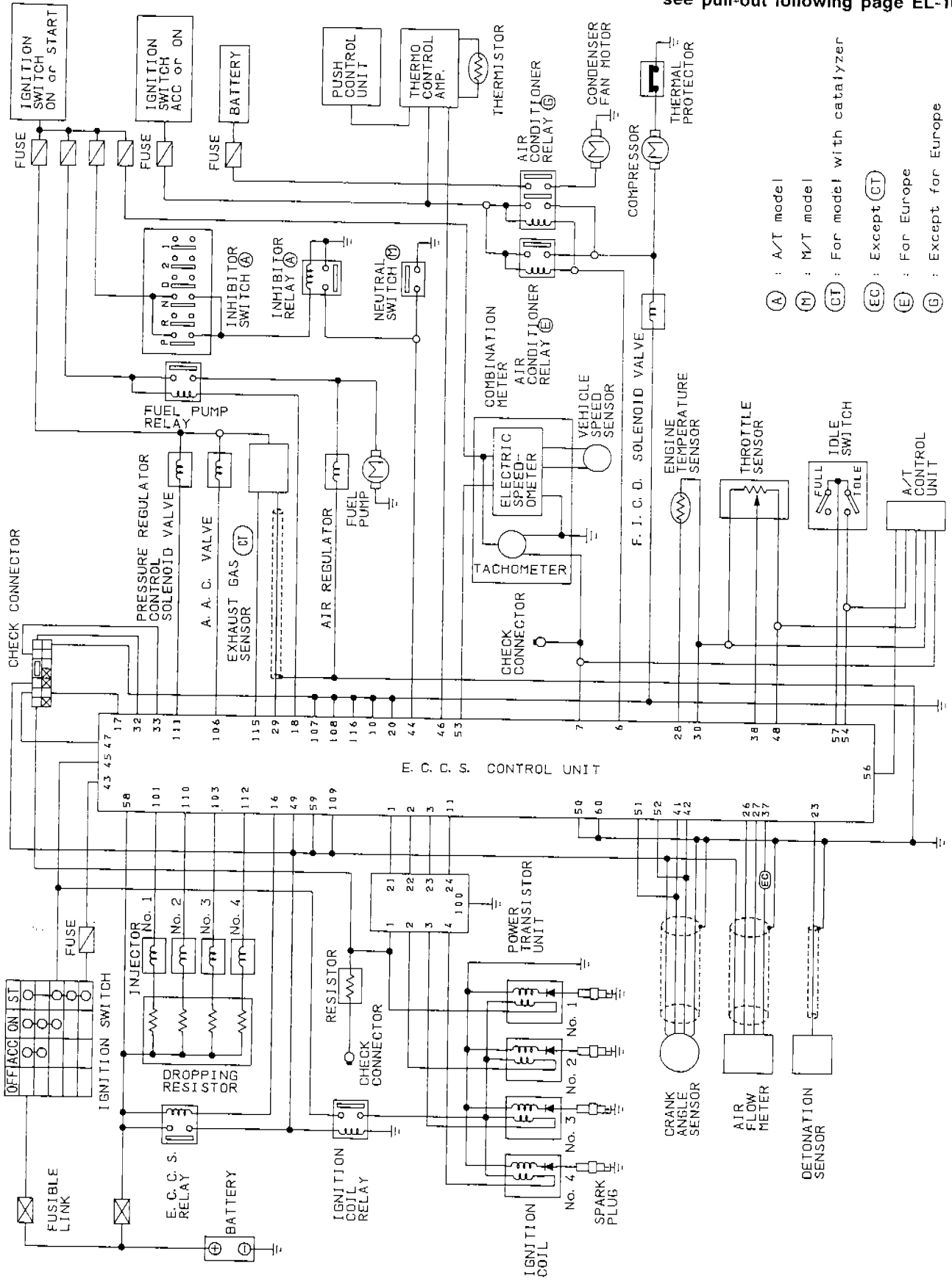

SEF400H

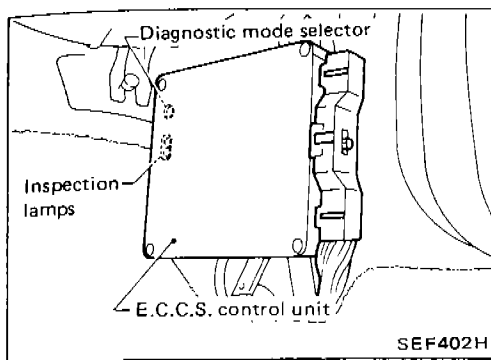

E.C.C.S. Control Unit (E.C.U.)

The E.C.U. consists of a microcomputer, inspection lamps, a diagnostic mode selector, and connectors for signal input and output and for power supply. The unit controls the engine.

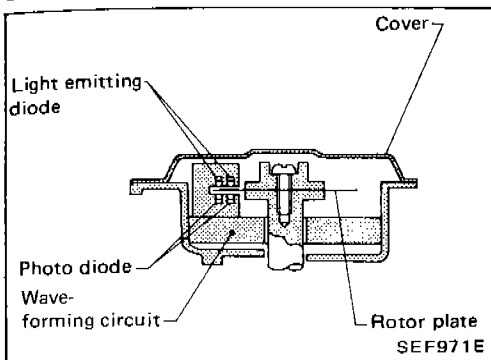

Crank Angle Sensor

The crank angle sensor is a basic component of the entire E.C.C.S. It monitors engine speed and piston position, and sends signals to the E.C.U. to control fuel injection, ignition timing and other functions.

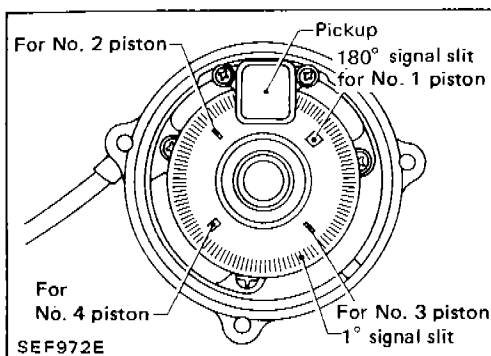

The crank angle sensor has a rotor plate and a wave-forming circuit. The rotor plate has 360 slits for 1° signal and 4 slits for 180° signal. Light Emitting Diodes (L.E.D.) and photo diodes are built in the wave-forming circuit.

When the rotor plate passes between the L.E.D. and the photo diode, the slits in the rotor plate continually cut the light being transmitted to the photo diode from the L.E.D. This generates rough-shaped pulses which are converted into on-off pulses by the wave-forming circuit, which are sent to the E.C.U.

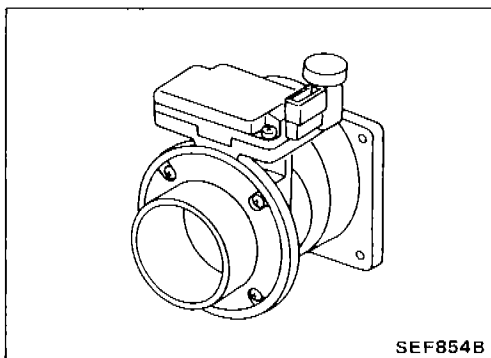

Air Flow Meter

The air flow meter measures the mass flow rate of intake air. Measurements are made so that the control circuit will emit an electrical output signal corresponding to the amount of heat dissipated from a hot wire placed in the stream of intake air.

The airflow past the hot wire removes the heat from the hot wire. The temperature of the hot wire is very sensitive to the mass flow rate. The higher the temperature of the hot wire, the greater its resistance value. This temperature change (resistance) is determined by the mass air flow rate. The control circuit accurately regulates current (I) in relation to the varying resistance value (R_H) so that V_A always equals V_B . The air flow meter transmits an output for voltage V_A to the control unit where the output is converted into an intake air signal.

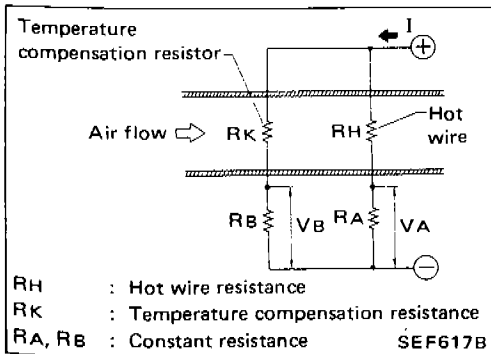

ENGINE AND EMISSION CONTROL PARTS DESCRIPTION

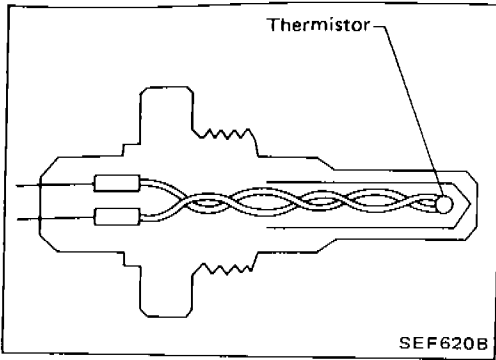

Engine Temperature Sensor

The engine temperature sensor detects the engine temperature, which is dependent on engine coolant, and transmits a signal to the E.C.U.

The temperature sensing unit employs a thermistor which is sensitive to the change in temperature. Electrical resistance of the thermistor decreases in response to the temperature rise.

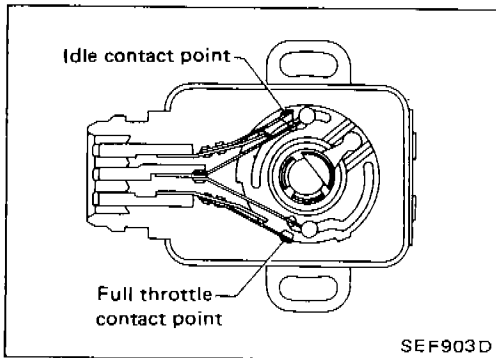

Throttle Sensor and Idle Switch

The throttle sensor responds to the accelerator pedal movement. This sensor is a kind of potentiometer which transforms the throttle valve position into output voltage, and emits the voltage signal to the E.C.U. In addition the sensor detects the opening and closing speed of the throttle valve, and feeds the voltage signal to the A/T control unit. The idle switch actuates in response to accelerator pedal movement.

This switch has idle contact and full throttle contact. The idle contact is used for engine control. It closes when the throttle valve is positioned at idle and opens when it is at any other position.

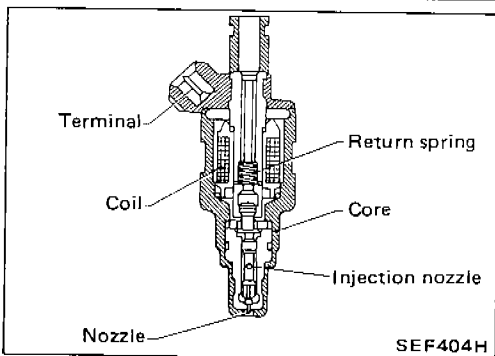
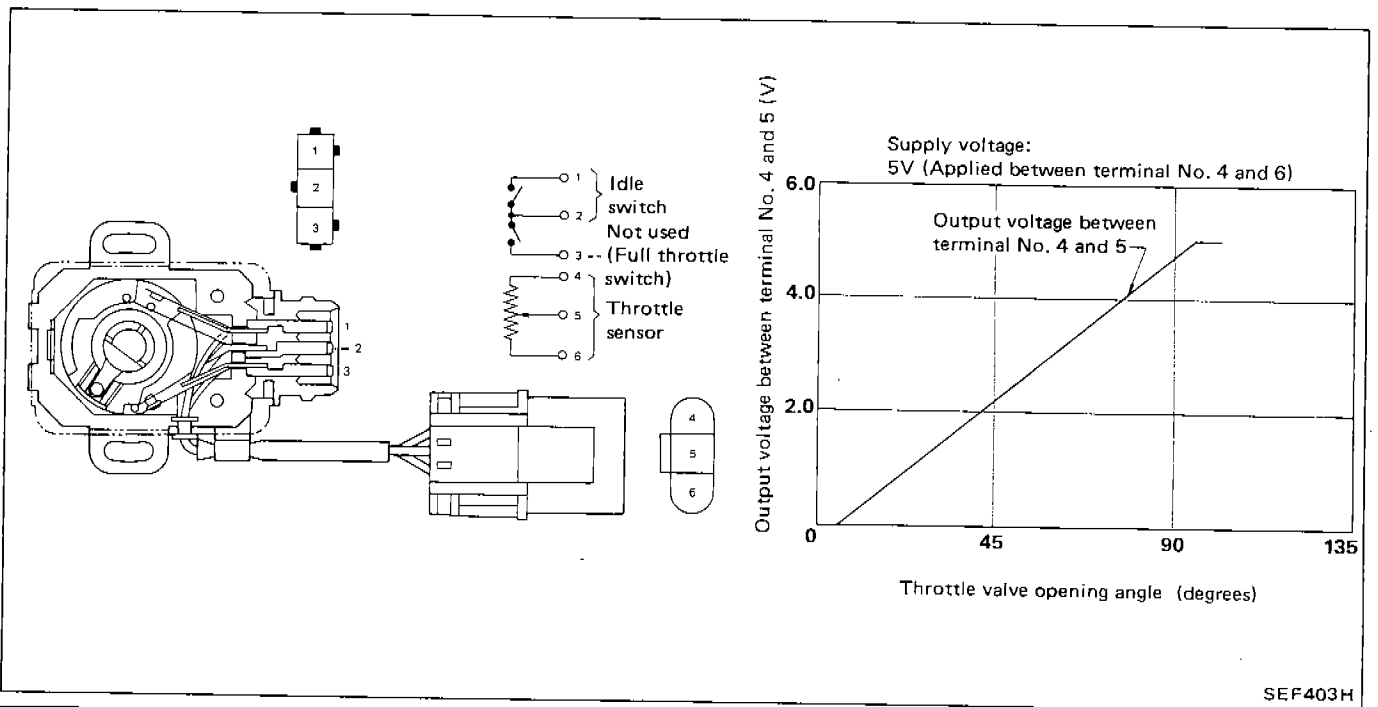

Fuel Injector

The fuel injector is a small, elaborate solenoid valve. As the E.C.U. sends injection signals to the injector, the coil in the injector pulls the needle valve back and fuel is released into the intake manifold through the nozzle. The injected fuel is controlled by the E.C.U. in terms of injection pulse duration.

ENGINE AND EMISSION CONTROL PARTS DESCRIPTION

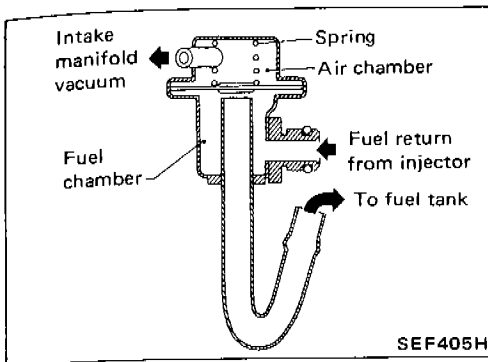

Pressure Regulator

The pressure regulator maintains the fuel pressure at 250.1 kPa (2.501 bar, 2.55 kg/cm², 36.3 psi). Since the injected fuel amount depends on injection pulse duration, it is necessary to maintain the pressure at the above value.

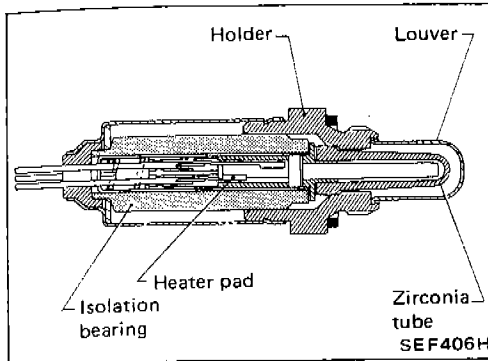

Exhaust Gas Sensor (For catalyzer model)

The exhaust gas sensor, which is placed into the exhaust outlet, monitors the amount of oxygen in the exhaust gas. The sensor has a closed-end tube made of ceramic zirconia. The outer surface of the tube is exposed to exhaust gas, and the inner surface to atmosphere. The zirconia of the tube compares the oxygen density of exhaust gas with that of atmosphere, and generates electricity. In order to improve generating power of the zirconia, its tube is coated with platinum. The voltage is approximately 1V in a richer condition of the mixture ratio than the ideal air-fuel ratio, while approximately 0V in leaner conditions. The radical change from 1V to 0V occurs at around the ideal mixture ratio. In this way, the exhaust gas sensor detects the amount of oxygen in the exhaust gas and sends the signal of approximately 1V or 0V to the E.C.U. A heater is used to activate the sensor.

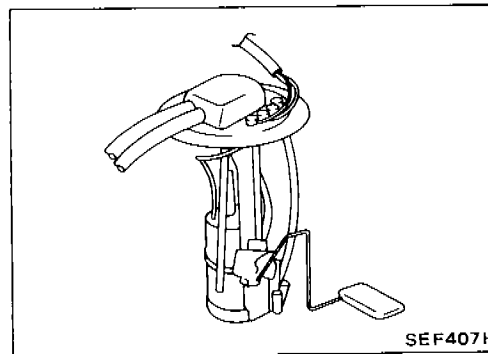
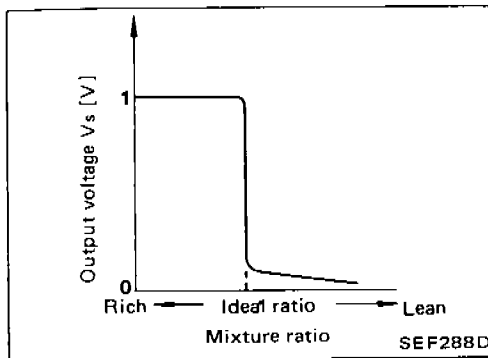

Fuel Pump

The fuel pump is an electric turbine type with the turbines directly connected to the motor. This assembly is located in the fuel tank.

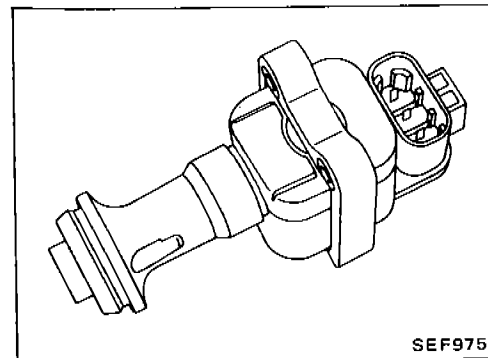

Ignition Coil

The ignition coil is a small, molded type.

IDLE SPEED/IGNITION TIMING/IDLE MIXTURE RATIO INSPECTION

INSPECTION PROCEDURE

For catalyzer model

INSPECTION START

Visually check the following:

- Air cleaner clogging
- Hoses and ducts for leaks
- Electrical connectors
- Gaskets
- Throttle valve and throttle valve switch operation

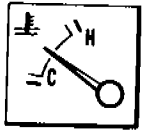

SEF457C

Start engine and warm it up until water temperature indicator points to the middle of gauge.

Open engine hood and run engine at about 2,000 rpm for about 2 minutes under no-load.

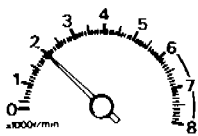

SEF477B

Perform E.C.C.S. self-diagnosis. (Select mode III)

O.K.

N.G.

Check, correct or replace malfunctioning parts.

Does engine run smoothly?

O.K.

N.G.

Check and clean injectors, and replace injectors if necessary.

Race engine two or three times under no-load, then run engine at idle speed.

Check idle speed.

M/T: 850±50 rpm

A/T: 850±50 rpm (in "N" position)

O.K.

N.G.

Check ignition timing with a timing light. Refer to page EF & EC-22.

15°±2° B.T.D.C.

N.G.

Adjust ignition timing by turning crank angle sensor after loosening bolts which secure it.

O.K.

Disconnect A.A.C. valve harness connector.

Adjust idle speed to 800 rpm by turning idle speed adjusting screw.

Connect A.A.C. valve harness connector.

A

B

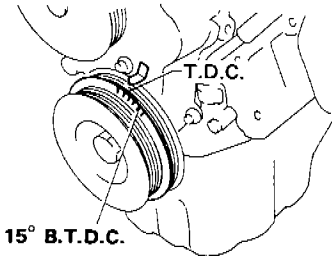

SEF131F

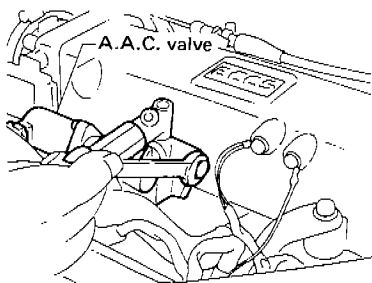

SEF647H

IDLE SPEED/IGNITION TIMING/IDLE MIXTURE RATIO INSPECTION

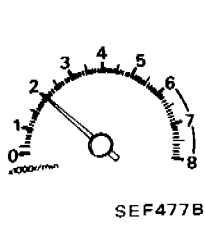

Run engine at about 2,000 rpm for about 2 minutes under no-load.

Make sure that inspection lamp (Green) on control unit goes on and off periodically more than 9 times during 10 seconds at 2,000 rpm under no-load. (Select mode I or II)

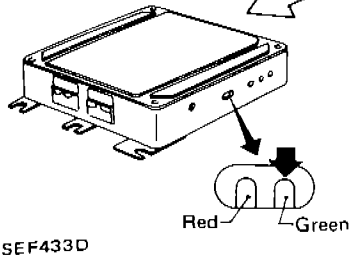

O.K. N.G.

Race engine two or three times under no-load, then run engine at idle speed.

Set the diagnosis mode of E.C.U. to No. 2 mode and check that inspection lamps (Red and Green) on control unit blink at 2,000 rpm under no-load. They should blink simultaneously.

Yes
INSPECTION END

No
C

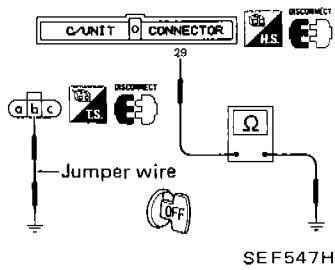

Check exhaust gas sensor harness:

- 1) Turn off engine and disconnect battery ground cable.
- 2) Disconnect connector from Control Unit.
- 3) Disconnect exhaust gas sensor harness connector and connect terminal for exhaust gas sensor harness connector to ground with a jumping wire.
- 4) Check for continuity between terminal No. 29 and ground metal on vehicle body.
- 5) Connect Control Unit connector and battery ground cable.

Continuity exists O.K.
Continuity does not exist N.G.

O.K. N.G.
Repair or replace E.C.C.S. harness.

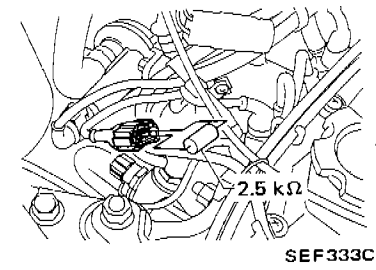

- Disconnect engine temperature sensor harness connector.
- Connect a resistor (2.5 kΩ) between terminals of engine temperature sensor harness connector.
- Disconnect A.A.C. valve harness connector.

D

B

TROUBLE DIAGNOSES

Electrical Components Inspection (Cont'd)

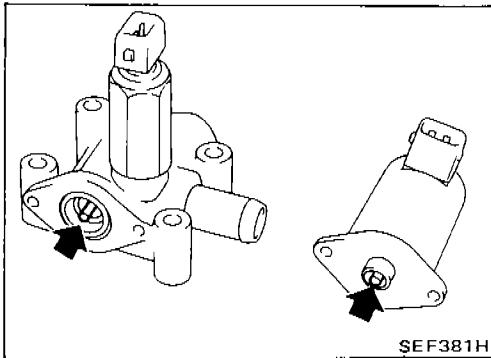

3. Remove A.A.C. valve
4. Check plunger for seizure or sticking.
5. Check spring for damage.

PRESSURE REGULATOR CONTROL SOLENOID VALVE

1. Check it for electric continuity.

Resistance:

30 - 40 Ω

(Above resistance has no change even if the polarity of the circuit tester is changed when measuring it.)

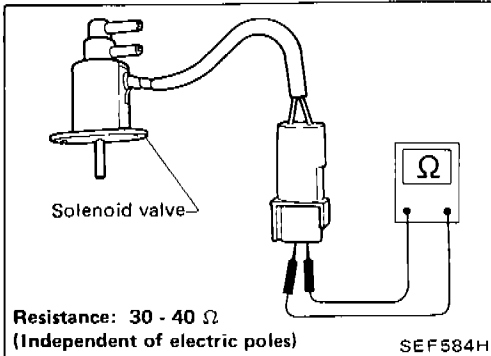

2. Check the solenoid valve for normal operation. Supply it with battery voltage, and check whether there is continuity between ports A, B and C.

| Solenoid valve | | OFF | ON |
|----------------|--|------|-----|
| | | Item | |
| Continuity | | B-C | A-B |

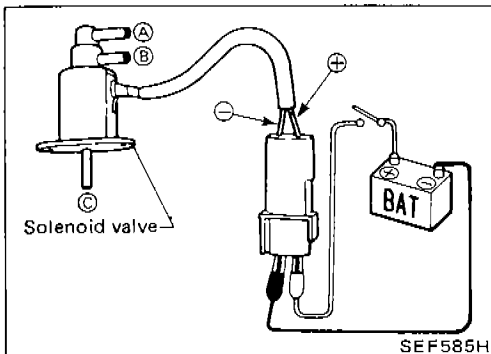

AIR REGULATOR

1. Check air regulator resistance.

Resistance:

Approximately 70 Ω

2. Check air regulator for clogging.

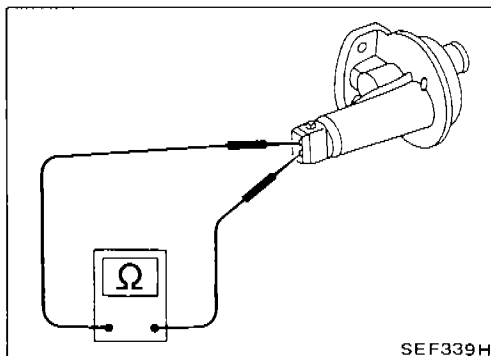

FUEL PUMP

1. Disconnect fuel pump harness connector. Check resistance between terminals a and c.

Resistance:

Approximately 0.5 Ω

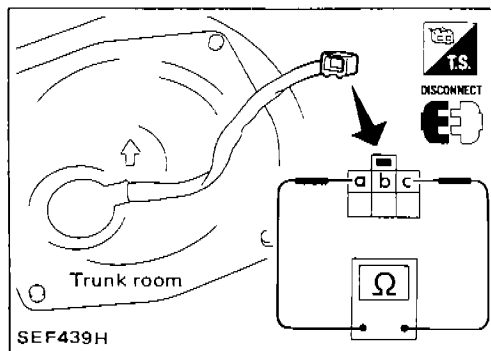

TROUBLE DIAGNOSES

Electrical Components Inspection (Cont'd)

- Check fuel pump for normal operation by supplying it with battery voltage between terminals **a** and **c**.

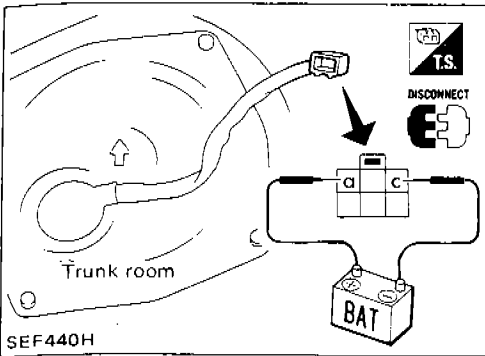

F.I.C.D. SOLENOID VALVE

- Check that clicking sound is heard when applying 12V direct current to terminals.

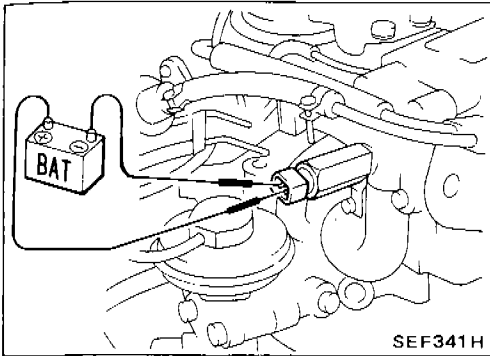

- Check plunger for seizure or sticking.
- Check for broken spring.

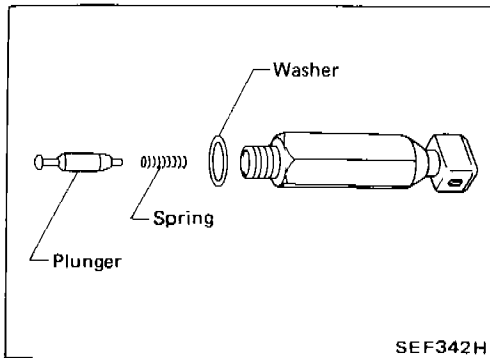

NEUTRAL SWITCH

Check continuity between terminals **a** and **b**.

| Conditions | Continuity |
|-------------------------|------------|
| Shift to Neutral | Yes |
| Shift to other position | No |

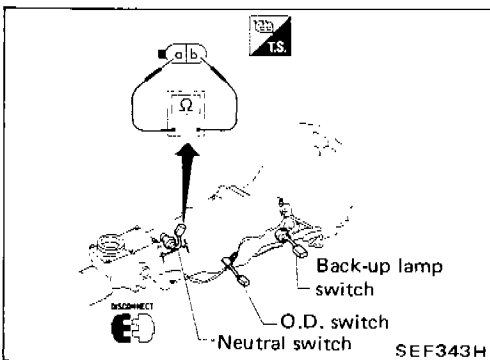

INHIBITOR SWITCH

Check continuity between terminals **a** and **b**, **f**.

| Conditions | Continuity between terminals a and b | Continuity between terminals a and f |
|-------------------------------------------|----------------------------------------------------|----------------------------------------------------|
| Shift to "P" position | Yes | No |
| Shift to "N" position | No | Yes |
| Shift to positions other than "P" and "N" | No | No |

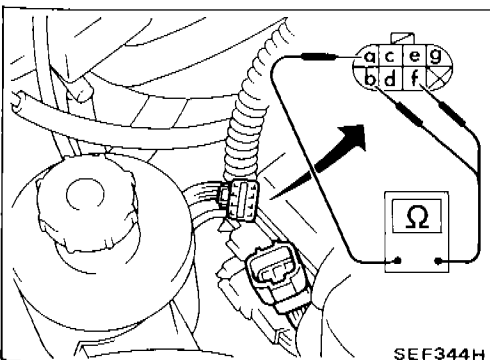

TROUBLE DIAGNOSES

Electrical Components Inspection (Cont'd) E.C.C.S. RELAY, FUEL PUMP RELAY AND INHIBITOR RELAY

Check continuity between terminals ③ and ⑤.

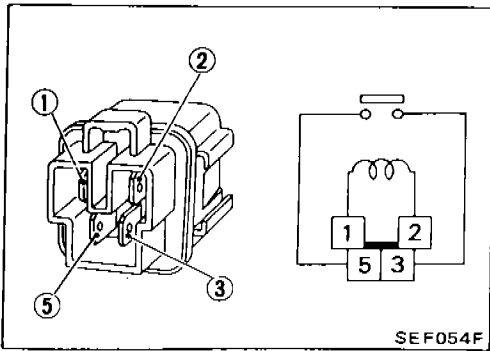

| Condition | Continuity |
|-----------------------------------------------------|------------|
| 12V direct current supply between terminals ① and ② | Yes |
| No supply | No |

DROPPING RESISTOR

1. Disconnect dropping resistor harness connector.
2. Check dropping resistor resistance.

Resistance:

Approximately 6Ω

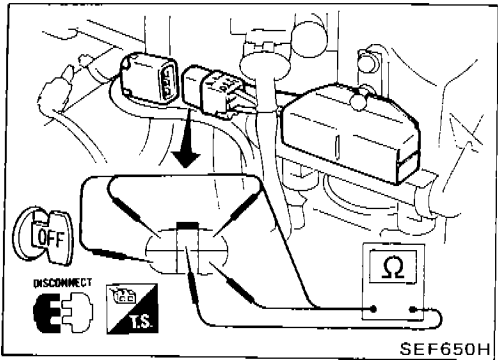

VEHICLE SPEED SENSOR

1. Jack up rear wheels.
2. Disconnect vehicle speed sensor harness connector.
3. Check continuity between terminals ① and ② while rotating rear wheel by hand.

Continuity should be intermittent.

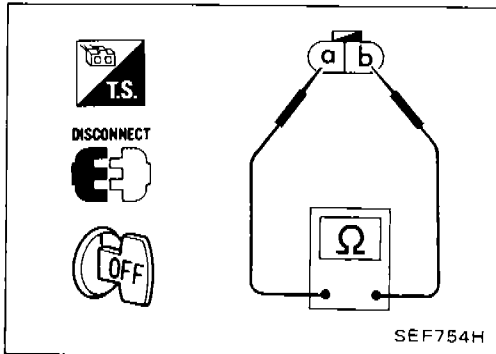

DETONATION SENSOR

1. Disconnect detonation sensor harness.
2. Check continuity between detonation sensor terminal and ground.

Continuity should exist.

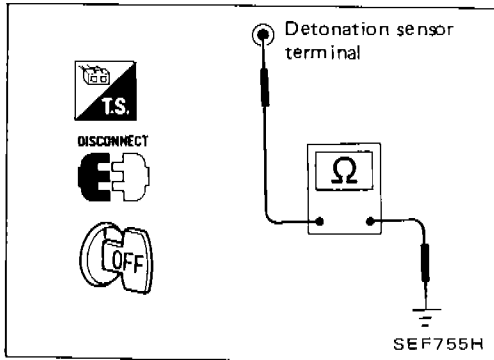

FUEL INJECTION CONTROL SYSTEM INSPECTION

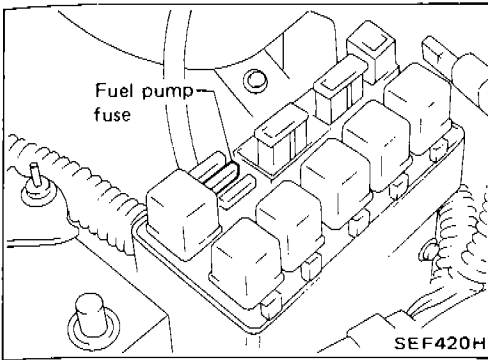

Releasing Fuel Pressure

Before disconnecting fuel line, release fuel pressure from fuel line to eliminate danger.

1. Remove fuse for fuel pump.
2. Start engine.
3. After engine stalls, crank it two or three times to release all fuel pressure.
4. Turn ignition switch off and reconnect fuel pump fuse.

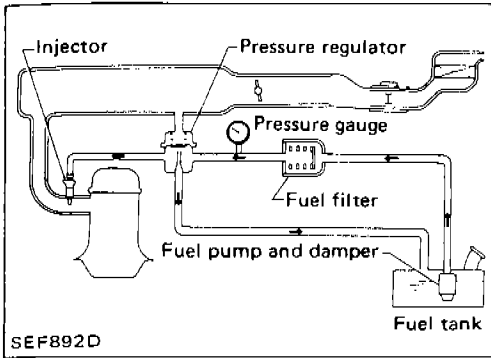

Fuel Pressure Check

- a. When reconnecting fuel line, always use new clamps.
 - b. Make sure that clamp screw does not contact adjacent parts.
 - c. Use a torque driver to tighten clamps.
 - d. Use Pressure Gauge to check fuel pressure.
 - e. Do not perform fuel pressure check while fuel pressure regulator control system is operating; otherwise, fuel pressure gauge might indicate incorrect readings.
1. Release fuel pressure to zero.
 2. Disconnect fuel hose between fuel filter and fuel tube (engine side).
 3. Install pressure gauge between fuel filter and fuel tube.
 4. Start engine and check for fuel leakage.

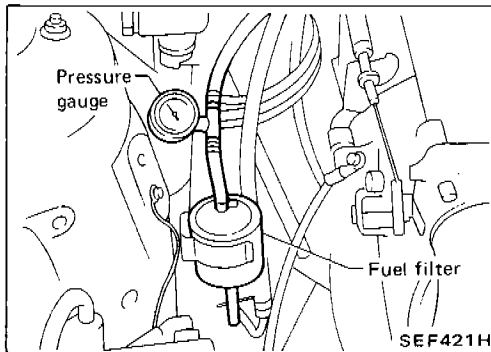

5. Read the indication of fuel pressure gauge.

At idling:

When fuel pressure regulator valve vacuum hose is connected.

**Approximately 196 kPa
(1.96 bar, 2.0 kg/cm², 28 psi)**

When fuel pressure regulator valve vacuum is disconnected.

**Approximately 245 kPa
(2.45 bar, 2.5 kg/cm², 36 psi)**

6. Stop engine and disconnect fuel pressure regulator vacuum hose from intake manifold.
7. Plug intake manifold with a rubber cap.
8. Connect variable vacuum source to fuel pressure regulator.

FUEL INJECTION CONTROL SYSTEM INSPECTION

Fuel Pressure Check (Cont'd)

9. Start engine and read indication of fuel pressure gauge as vacuum is changed.

Fuel pressure should decrease as vacuum increases. If results are unsatisfactory, replace fuel pressure regulator.

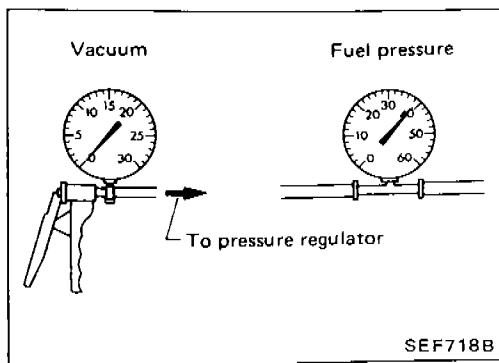

Injector Removal and Installation

1. Release fuel pressure to zero.
2. Remove I.A.A. unit and intake manifold stay.
3. Disconnect pressure regulator vacuum hose.
4. Remove fuel tube assembly fixing bolts.

Be careful not to damage the injector, nor to deform the fuel tube.

5. Remove injectors from fuel tube.

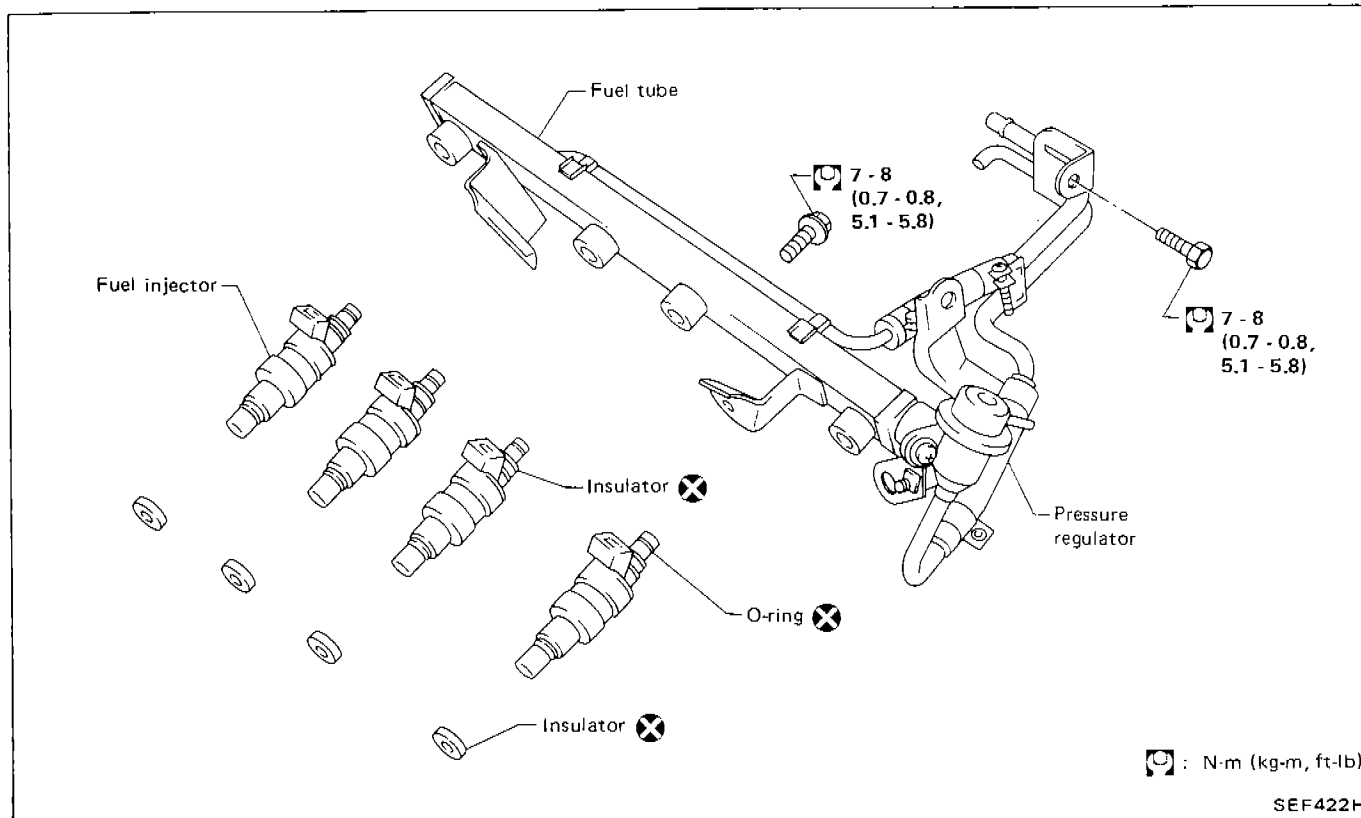

CAUTION:

- Do not reuse old O-rings.
- Apply a coat of engine oil (SAE 10W-30) to new O-rings. Do not use solvent for wiping.
- Keep O-rings and their mating parts clean and free from foreign particles (dirt, ravelings, etc.) before installation.
- Do not scratch the O-ring either with tools or finger nails during installation. Be careful not to expand or twist excessively. Do not insert into fuel tube immediately after expansion.

FUEL INJECTION CONTROL SYSTEM INSPECTION

Injector Removal and Installation (Cont'd)

- Do not attempt to rotate or twist fuel injector and pressure regulator when inserting into fuel tube.
 - Do not store O-rings in an area where ozone, oxygen, humidity, etc. are relatively high. Do not expose them to direct sunlight.
 - After properly connecting fuel injector to fuel tube, check connection for fuel leakage.
6. Assemble injectors with fuel tube.
 7. Install fuel tube assembly.

EVAPORATIVE EMISSION CONTROL SYSTEM (For catalyzer model)

Description

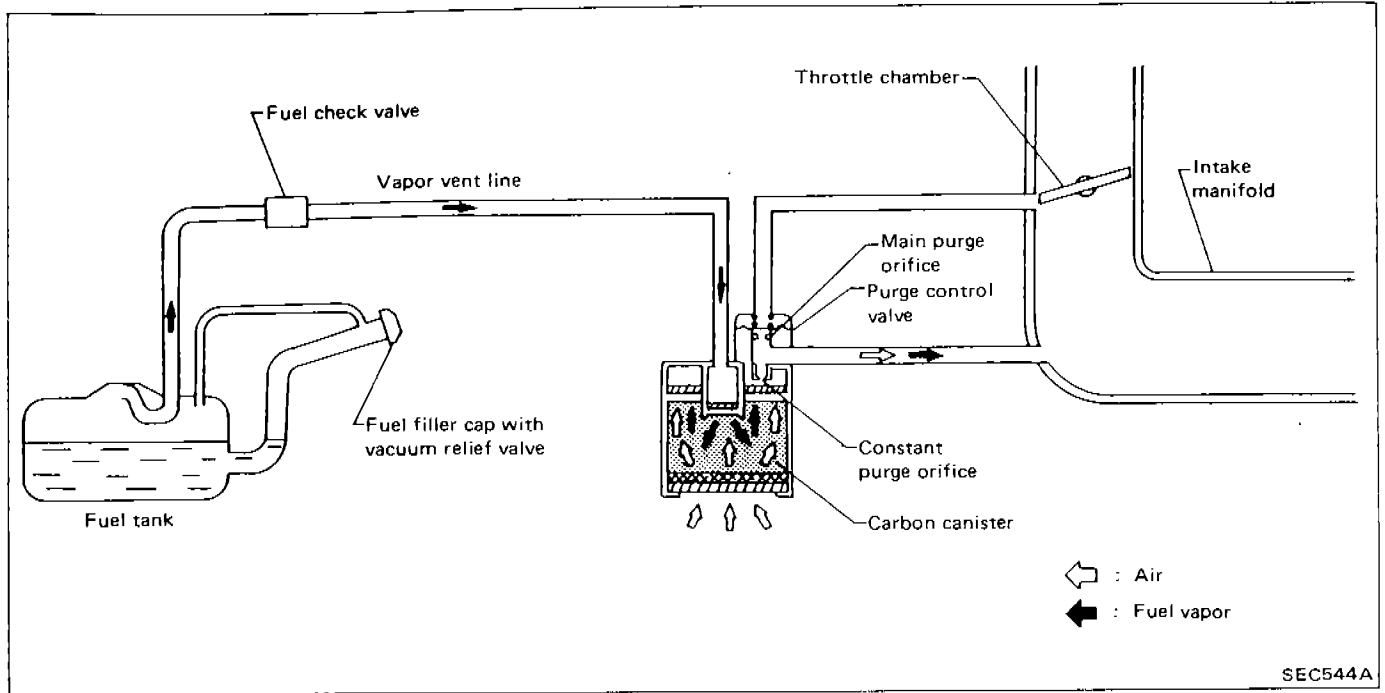

The evaporative emission control system is used to reduce hydrocarbons emitted to the atmosphere from the fuel system. This reduction of hydrocarbons is accomplished by activated charcoals in the carbon canister.

The fuel vapor from the sealed fuel tank is led into the canister which contains activated carbon and the vapor is stored there when the engine is not running.

The canister retains the fuel vapor until the canister is purged by the air drawn through the bottom of the canister to the intake manifold when the engine is running. When the engine runs at idle, the purge control valve is closed.

Only a small amount of stored vapor flows into the intake manifold through the constant purge orifice. As the engine speed increases, and the throttle vacuum rises higher, the purge control valve opens and the vapor is sucked into the intake manifold through both the main purge orifice and the constant purge orifice.

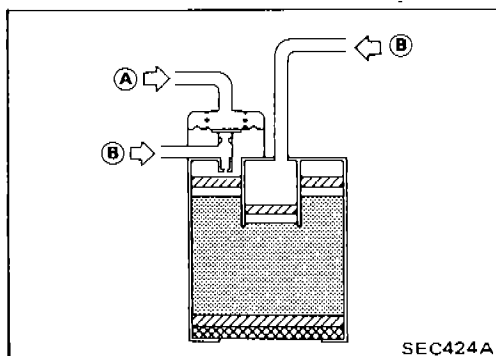

Inspection

CARBON CANISTER

Check carbon canister as follows:

- (A) : Blow air and ensure that there is no leakage.
- (B) : Blow air and ensure that there is leakage.

EVAPORATIVE EMISSION CONTROL SYSTEM (For catalyzer model)

Inspection (Cont'd)

FUEL TANK VACUUM RELIEF VALVE

1. Wipe clean valve housing.
2. Inhale air through the cap. A slight resistance accompanied by valve clicks indicates that valve is in good mechanical condition. Note also that, by further inhaling air, the resistance should disappear with valve clicks.
3. If valve is clogged or if no resistance is felt, replace cap as an assembly.

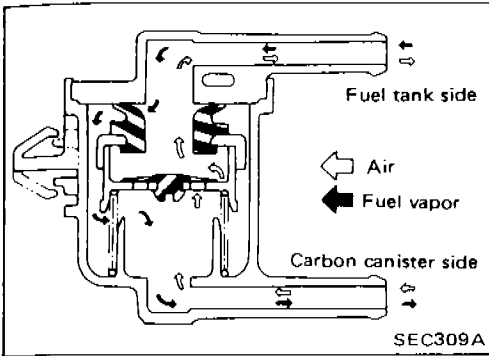
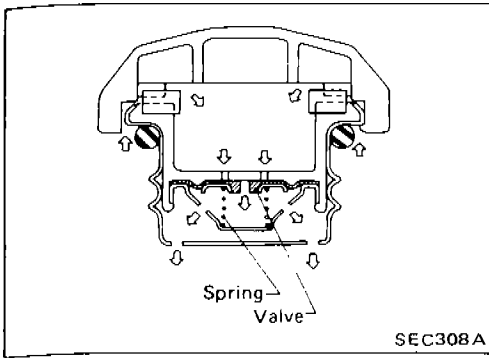

FUEL CHECK VALVE

1. Blow air through connector on fuel tank side.
A considerable resistance should be felt and a portion of air flow should be directed toward the canister.
2. Blow air through connector on canister side.
Air flow should be smoothly directed toward fuel tank.
3. If fuel check valve is suspected of not properly functioning in steps 1 and 2 above, replace it.

CRANKCASE EMISSION CONTROL SYSTEM

Description

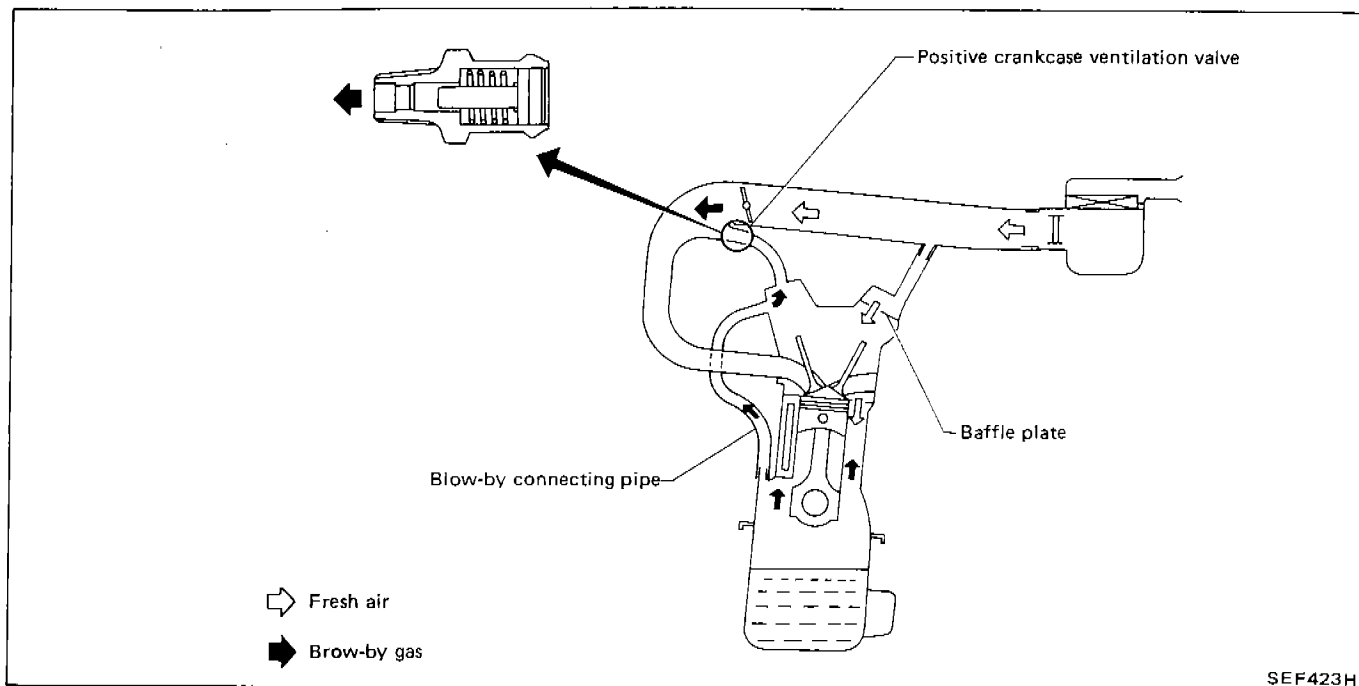

This system returns blow-by gas to the intake manifold. The positive crankcase ventilation (P.C.V.) valve is provided to conduct crankcase blow-by gas to the intake manifold. During partial throttle operation of the engine, the intake manifold sucks the blow-by gas through the P.C.V. valve. Normally, the capacity of the valve is sufficient to handle any blow-by and a small amount of ventilating air. The ventilating air is then drawn from the air cleaner, through the hose connecting air inlet to rocker cover, into the crankcase. Under full-throttle condition, the manifold vacuum is insufficient to draw the blow-by flow through the valve, and its flow goes through the hose connection in the reverse direction. On vehicles with an excessively high blow-by some of the flow will go through the hose connection to the air inlet under all conditions.

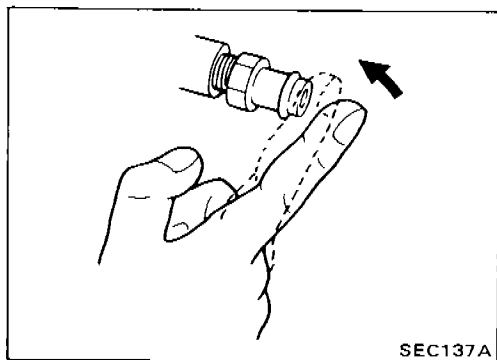

Inspection

P.C.V. (Positive Crankcase Ventilation) VALVE

With engine running at idle, remove ventilation hose from P.C.V. valve; if valve is working properly, a hissing noise will be heard as air passes through it and a strong vacuum should be felt immediately when a finger is placed over valve inlet.

CRANKCASE EMISSION CONTROL SYSTEM

Inspection (Cont'd) VENTILATION HOSE

1. Check hoses and hose connections for leaks.
2. Disconnect all hoses and clean with compressed air. If any hose cannot be freed of obstructions, replace.

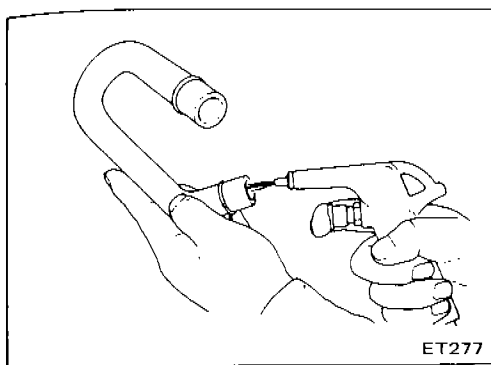

SERVICE DATA AND SPECIFICATIONS (S.D.S.)

General Specifications

| | |
|-------------------------------------|---------------------|
| PRESSURE REGULATOR | |
| Regulated pressure | 250.1 |
| kPa (bar, kg/cm ² , psi) | (2.501, 2.55, 36.3) |

Inspection and Adjustment

| | | |
|-------------------------------------------------------------|-------------------------------------|------------------------------------|
| AIR FLOW METER | | |
| Output voltage | V | 1.0 - 3.0 |
| ENGINE TEMPERATURE SENSOR | | |
| Thermistor resistance | k Ω | Approx. 2.5 |
| at 20°C (68°F) | | |
| at 80°C (176°F) | | Approx. 0.3 |
| THROTTLE VALVE SWITCH | | |
| Engine speed when idle switch is changed from "OFF" to "ON" | | Idle speed + 250 \pm 150 |
| | rpm | |
| FUEL PRESSURE | | |
| At idle | kPa (bar, kg/cm ² , psi) | 196 (1.96, 2.0, 28) |
| FUEL INJECTOR | | |
| Coil resistance | Ω | 2 - 3 |
| IDLE SPEED | rpm | |
| M/T model | | 850 \pm 50 |
| A/T model in "N" position | | |
| IDLE SPEED (A/C ON) | | |
| M/T model | | 950 \pm 50 |
| A/T model in "N" position | | 900 \pm 50 |
| IGNITION TIMING (B.T.D.C.) | | |
| M/T | | 15° \pm 2° |
| A/T | | |
| IDLE CO | % | Idle mixture is preset at factory. |
| AIR REGULATOR | Ω | Approx. 70 |
| IGNITION COIL | | |
| Primary resistance [at 20°C (68°F)] | Ω | 0.6 - 0.8 |
| Secondary resistance [at 20°C (68°F)] | k Ω | 6 - 8 |

ENGINE CONTROL, FUEL & EXHAUST SYSTEMS

SECTION **FE**

CONTENTS

| | |
|-----------------------------|------|
| ENGINE CONTROL SYSTEM | FE-2 |
| FUEL SYSTEM | FE-3 |
| EXHAUST SYSTEM | FE-4 |

FE

ENGINE CONTROL SYSTEM

Accelerator Control System

- When removing accelerator wire, make a mark to indicate lock nut's initial position.
- Check that throttle valve fully opens when accelerator pedal is fully depressed and that it returns to idle position when pedal is released.
- Adjust accelerator wire according to the following procedure.
Tighten "adjusting nut" until "throttle drum" starts to move.
From that position turn back "adjusting nut" 1.5 to 2 turns, and fasten it with a lock nut.
- Check accelerator control parts for improper contact with any adjacent parts.
- When connecting accelerator wire, be careful not to twist or scratch its inner wire.

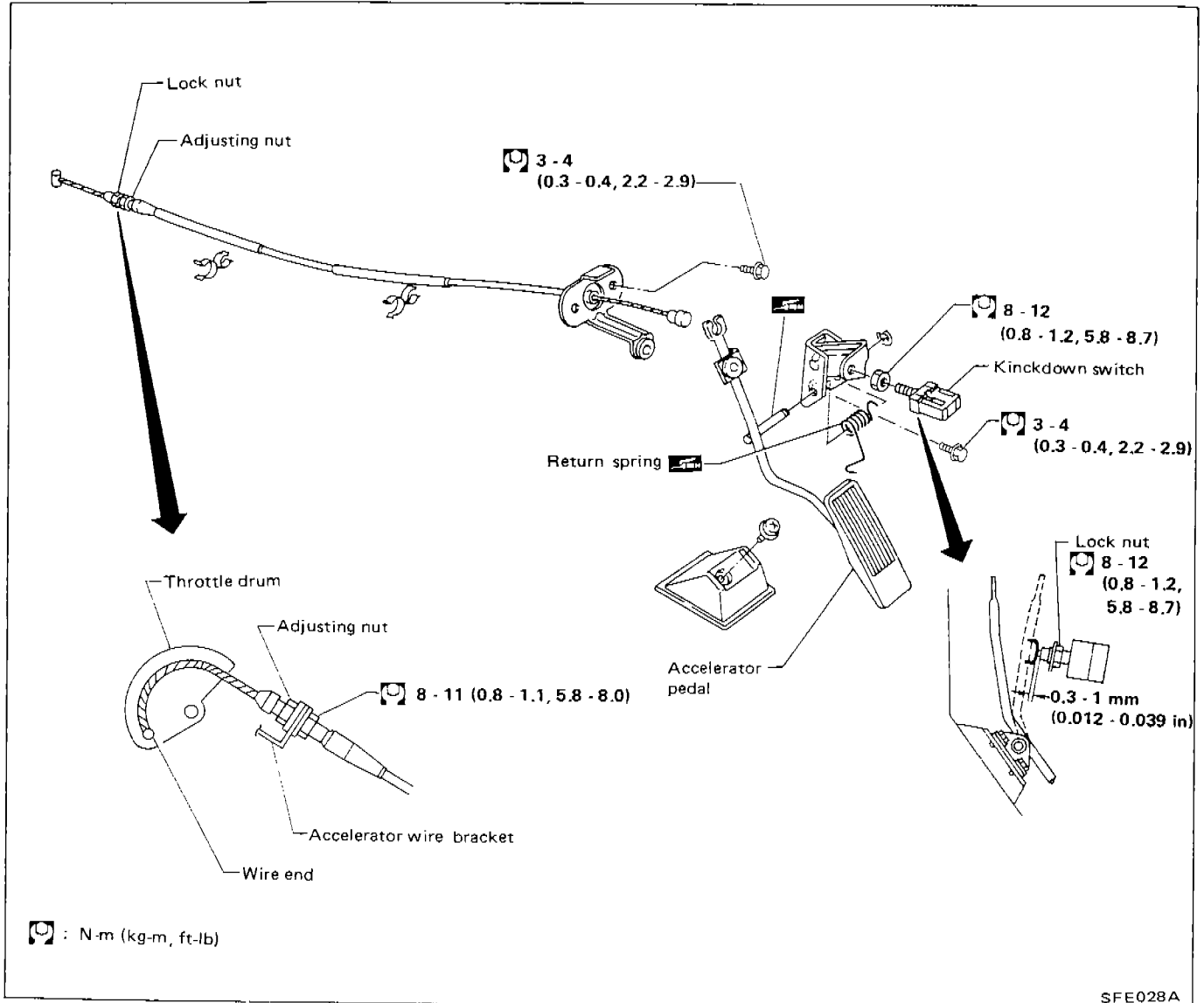

FUEL SYSTEM

WARNING:

When replacing fuel line parts, be sure to observe the following:

- Put a "CAUTION: INFLAMMABLE" sign in workshop.
- Do not smoke while servicing fuel system. Keep open flames and sparks away from work area.
- Be sure to disconnect battery ground cable before conducting operations.
- Put drained fuel in an explosion-proof container and put lid on securely.

CAUTION:

- For electric fuel pump model, before disconnecting fuel hose, release fuel pressure from fuel line. Refer to "Changing Fuel Filter" in MA section.
- Do not disconnect any fuel line unless absolutely necessary.
- Plug hose and pipe openings to prevent entry of dust or dirt.
- Always replace O-ring and clamps with new ones.
- Do not kink or twist hose and tube when they are installed.
- Do not tighten hose clamps excessively to avoid damaging hoses.
- When installing fuel check valve, be careful of its designated direction. (Refer to section EF & EC.)
- Run engine and check for leaks at connections.

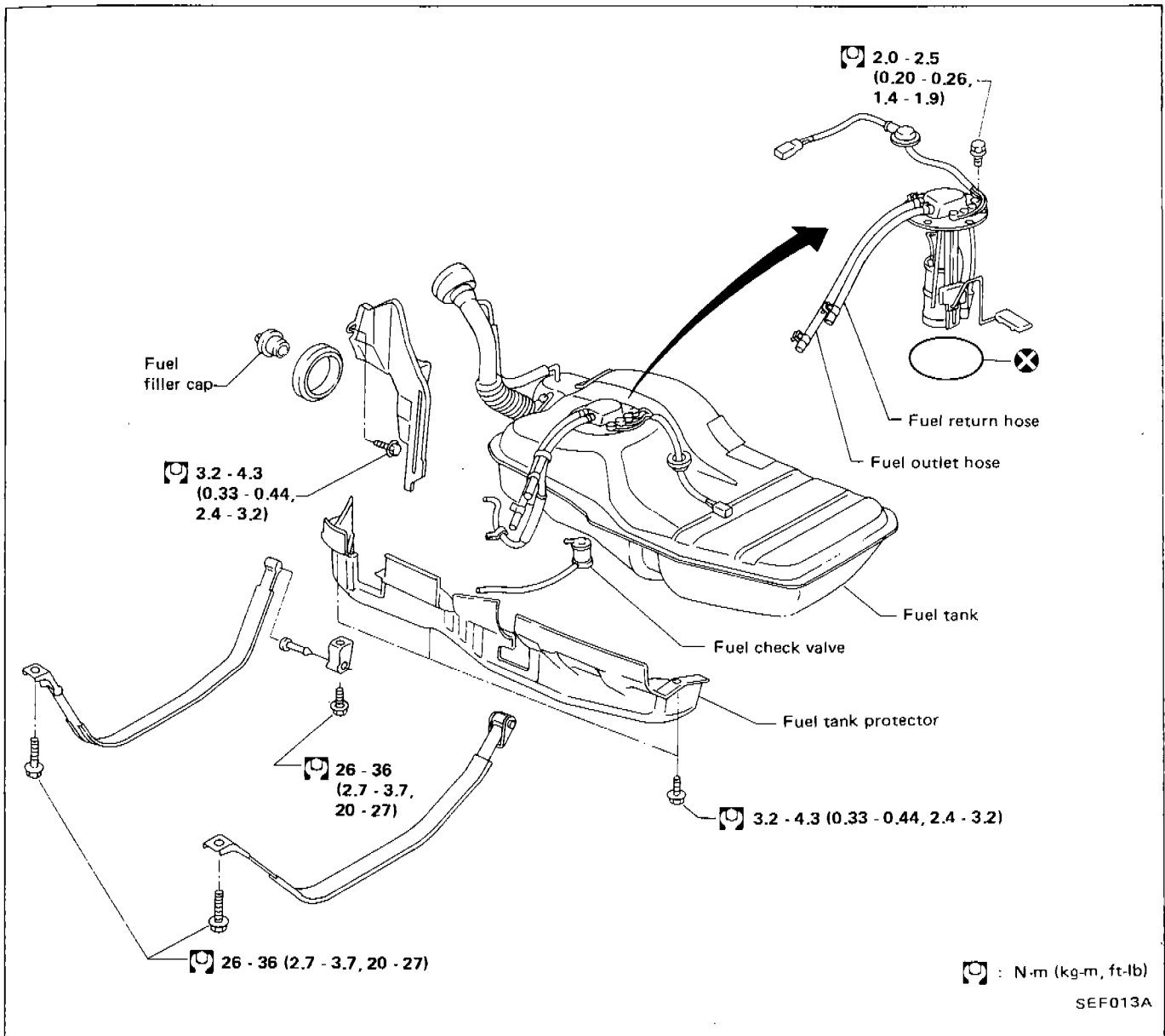

EXHAUST SYSTEM

CAUTION:

- Always replace exhaust gaskets with new ones when disassembling.
- Check all tube connections for exhaust gas leaks, and entire system for unusual noises, with engine running.
- After installation, check that mounting brackets and mounting insulator are free from undue stress. If any of above parts are not installed properly, excessive noise or vibration may be transmitted to vehicle body.

Model with catalyzer

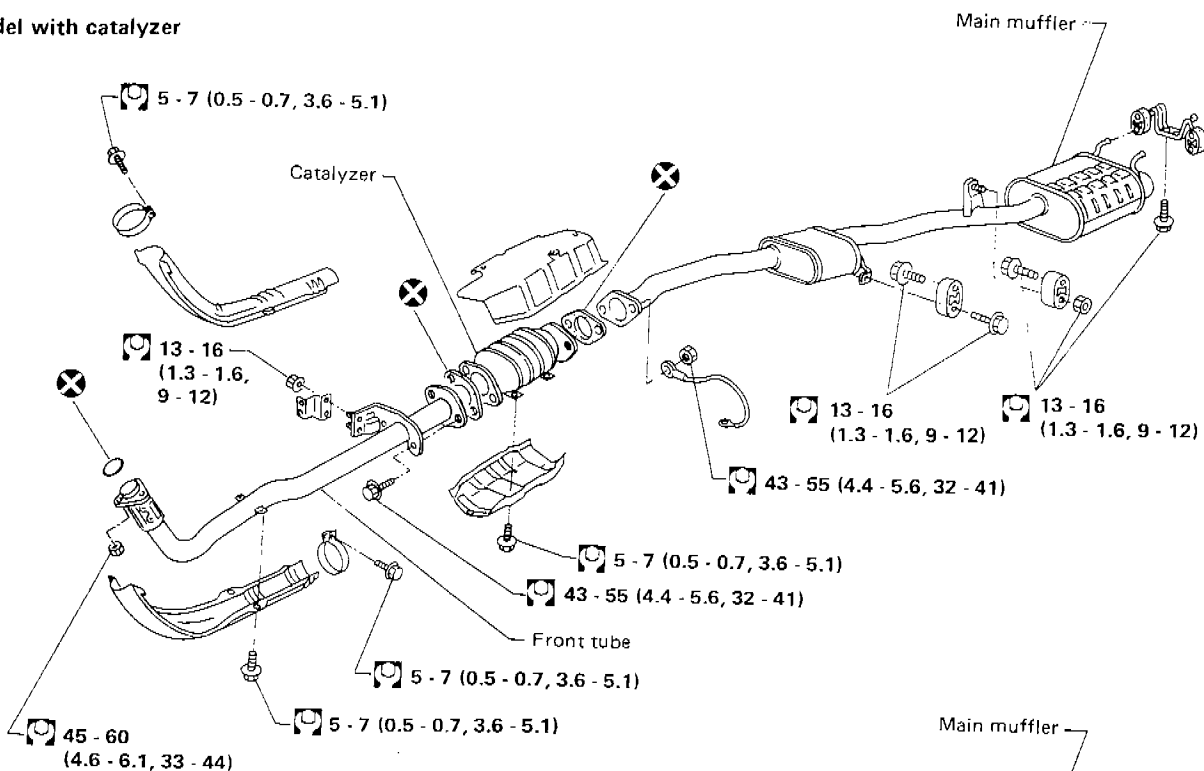

Model without catalyzer

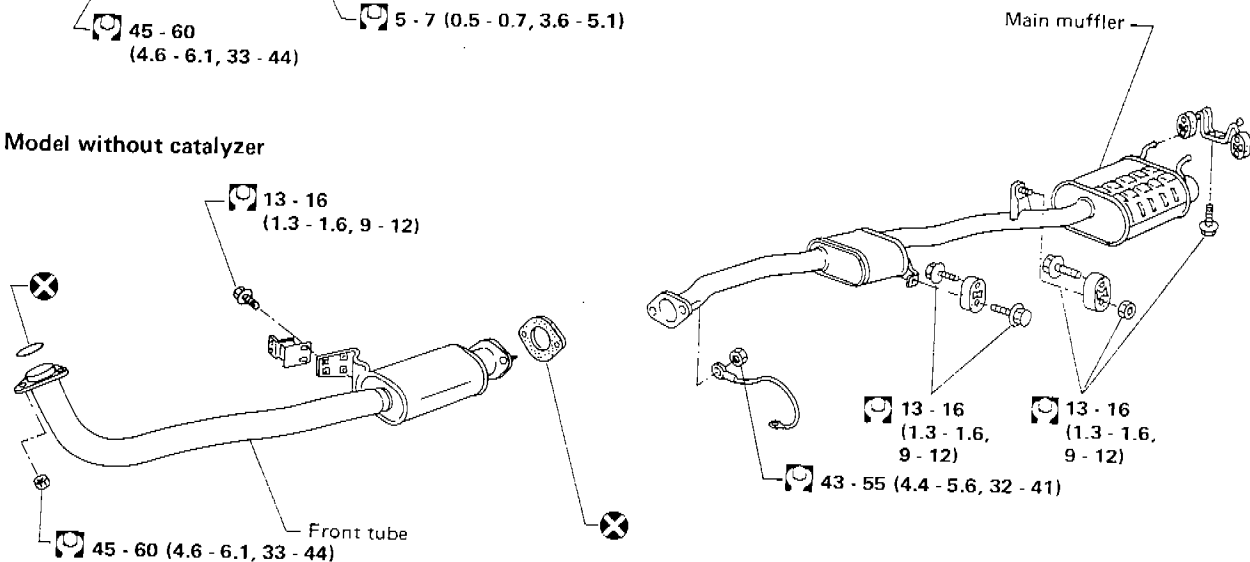

: N·m (kg-m, ft-lb)

SFE182A

CLUTCH

SECTION **CL**

CONTENTS

| | |
|------------------------------------------------|-------|
| PRECAUTIONS AND PREPARATION | CL- 2 |
| CLUTCH SYSTEM | CL- 4 |
| INSPECTION AND ADJUSTMENT | CL- 5 |
| HYDRAULIC CLUTCH CONTROL | CL- 6 |
| CLUTCH RELEASE MECHANISM | CL- 8 |
| CLUTCH DISC AND CLUTCH COVER | CL-10 |
| SERVICE DATA AND SPECIFICATIONS (S.D.S.) | CL-12 |

CL

PRECAUTIONS AND PREPARATION

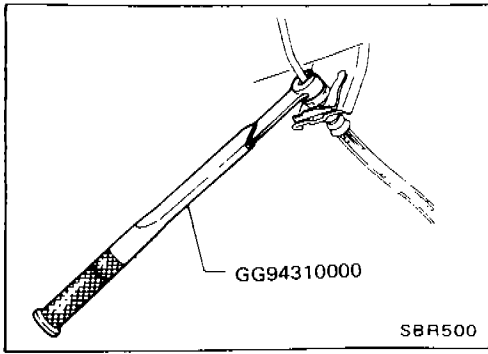

Precautions

- Recommended fluid is brake fluid "DOT 3".
- Never reuse drained brake fluid.
- Be careful not to splash brake fluid on painted areas.
- When removing and installing clutch piping, use Tool.
- Use new brake fluid to clean or wash all parts of master cylinder, operating cylinder and clutch damper.
- Never use mineral oils such as gasoline or kerosene. It will ruin the rubber parts of the hydraulic system.



WARNING:

After cleaning the clutch disc, wipe it with a dust collector. Do not use compressed air.

Preparation

SPECIAL SERVICE TOOLS

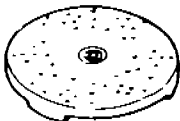
*: Special tool or commercial equivalent

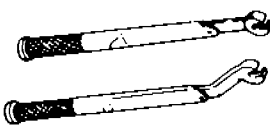
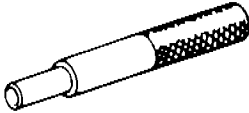
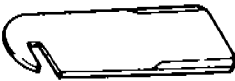
| Tool number Tool name | Description | |
|--------------------------------------------------|-------------------------------------------------------------------------------------|----------------------------------------------------------|
| ST20050010 Base plate |  | Inspecting diaphragm spring of clutch cover |
| ST20050100 Distance piece |  | Inspecting diaphragm spring of clutch cover |
| GG94310000* Flare nut torque wrench |  | Removing and installing each clutch piping |
| ST20600000* Clutch aligning bar |  | Installing clutch cover and clutch disc |
| ST20050240* Diaphragm spring adjusting wrench |  | Adjusting unevenness of diaphragm spring of clutch cover |

PRECAUTIONS AND PREPARATION

Preparation (Cont'd)

COMMERCIAL SERVICE TOOLS

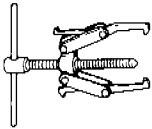
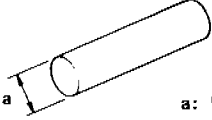
| Tool name | Description |
|----------------|--------------------------------------------------------------------------------------------------------------|
| Bearing puller |  Removing release bearing |
| Bearing drift |  a: 50 mm (1.97 in) dia. |

CLUTCH SYSTEM

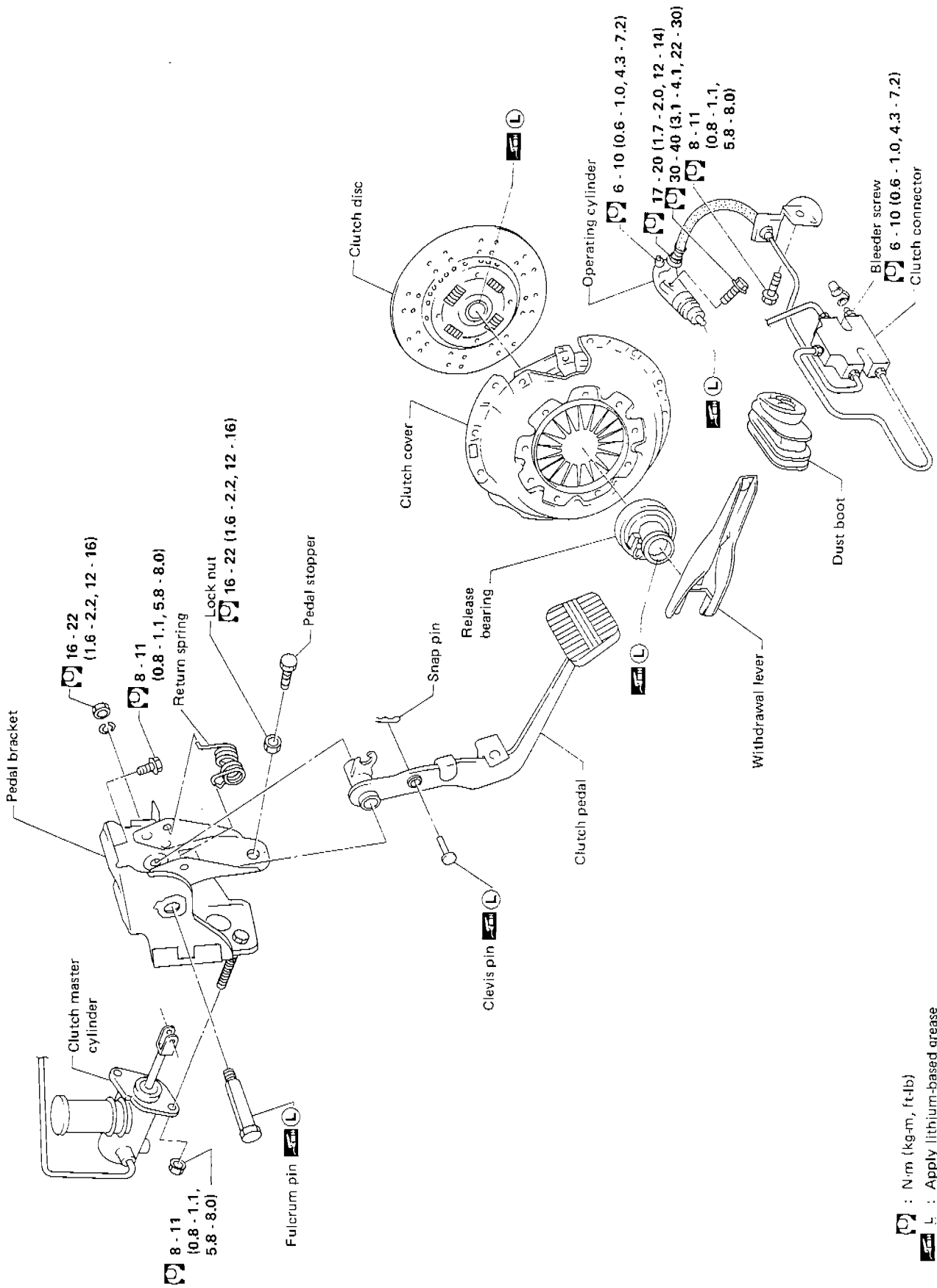

CL-4

N : N·m (kg·m, ft·lb)
 L : Apply lithium-based grease including molybdenum disulphide.

SCL356

INSPECTION AND ADJUSTMENT

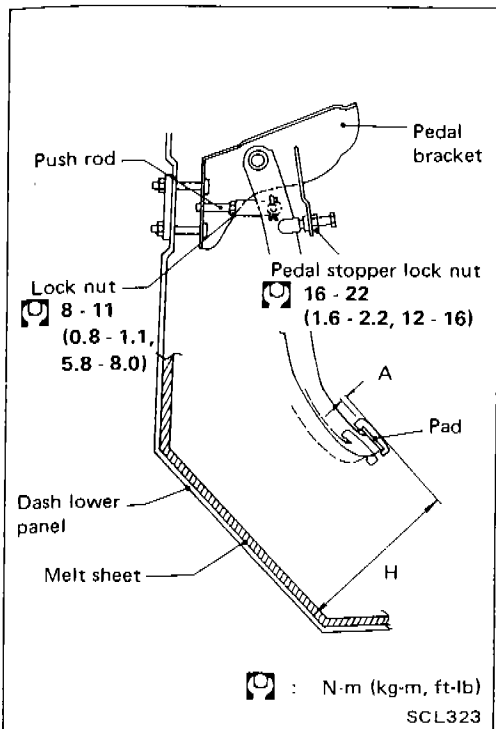

Adjusting Clutch Pedal

1. Adjust pedal height with pedal stopper.

Pedal height "H":

L.H. 186 - 196 mm (7.32 - 7.72 in)

R.H. 182 - 192 mm (7.17 - 7.56 in)

2. Adjust pedal free play with master cylinder push rod. Then tighten lock nut.

Pedal free play "A":

1.0 - 3.0 mm (0.039 - 0.118 in)

Pedal free play means the following total measured at position of pedal pad:

- Play due to clevis pin and clevis pin hole in clutch pedal.
- Play due to piston and push rod.

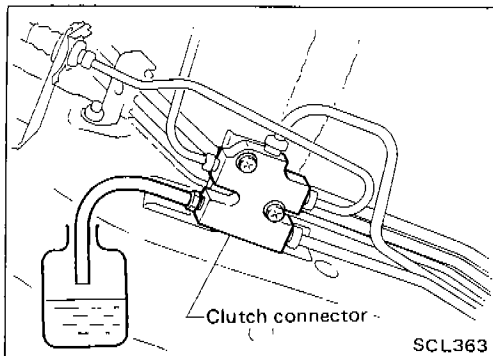

Bleeding Procedure

Bleed air according to the following procedure.

Clutch connector → Clutch operating cylinder

- Carefully monitor fluid level at master cylinder during bleeding operation.
1. Top up reservoir with recommended brake fluid.
 2. Connect a transparent vinyl tube to air bleeder valve.
 3. Fully depress clutch pedal several times.
 4. With clutch pedal depressed, open bleeder valve to release air.
 5. Close bleeder valve.
 6. Repeat steps 3 through 5 above until brake fluid flows from air bleeder valve without air bubbles.

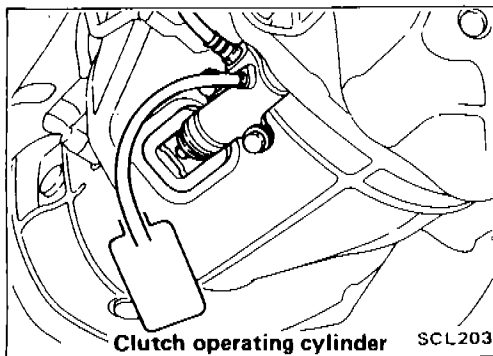

HYDRAULIC CLUTCH CONTROL

Clutch Master Cylinder (Cont'd)

INSPECTION

- Check cylinder and piston rubbing surface for uneven wear, rust or damage. Replace if necessary.
- Check piston with piston cup for wear or damage. Replace if necessary.
- Check return spring for wear or damage. Replace if necessary.
- Check reservoir for deformation or damage. Replace if necessary.
- Check dust cover for cracks, deformation or damage. Replace if necessary.

Operating Cylinder

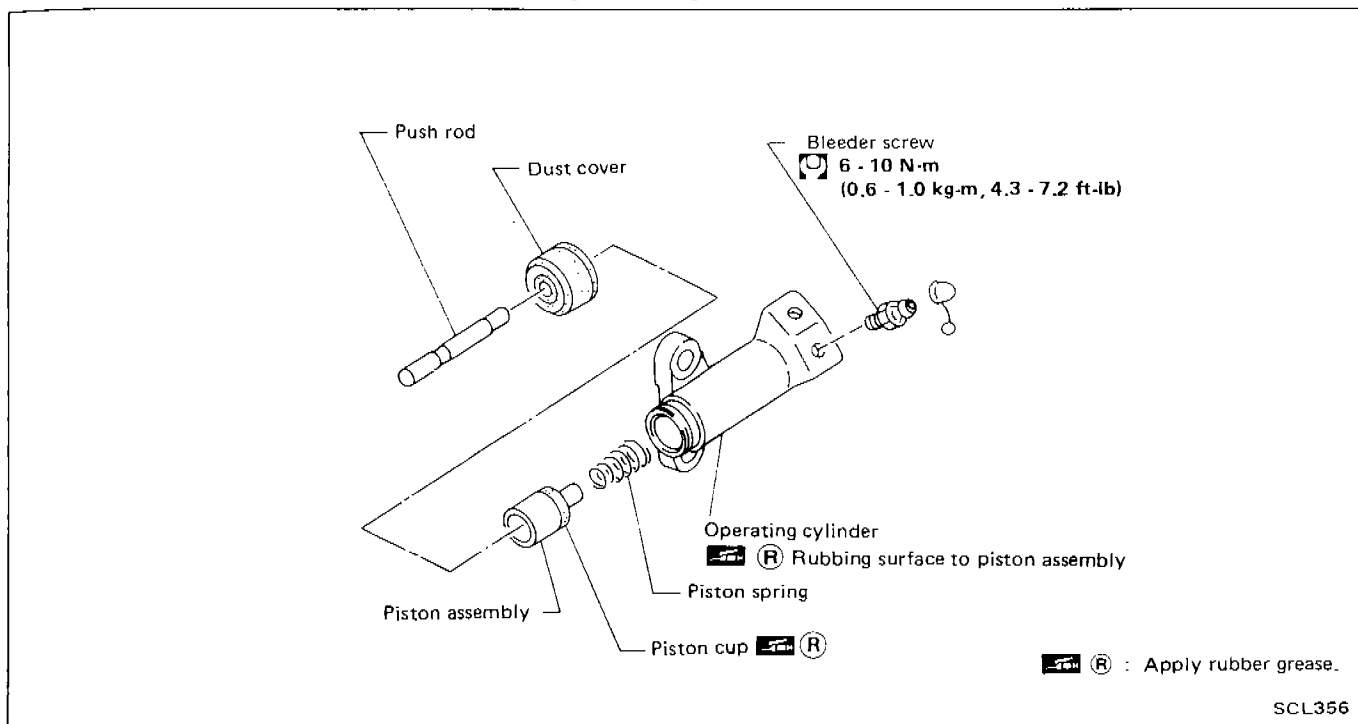

INSPECTION

- Check rubbing surface of cylinder for wear, rust or damage. Replace if necessary.
- Check piston with piston cup for wear or damage. Replace if necessary.
- Check piston spring for wear or damage. Replace if necessary.
- Check dust cover for cracks, deformation or damage. Replace if necessary.

HYDRAULIC CLUTCH CONTROL

Clutch Master Cylinder

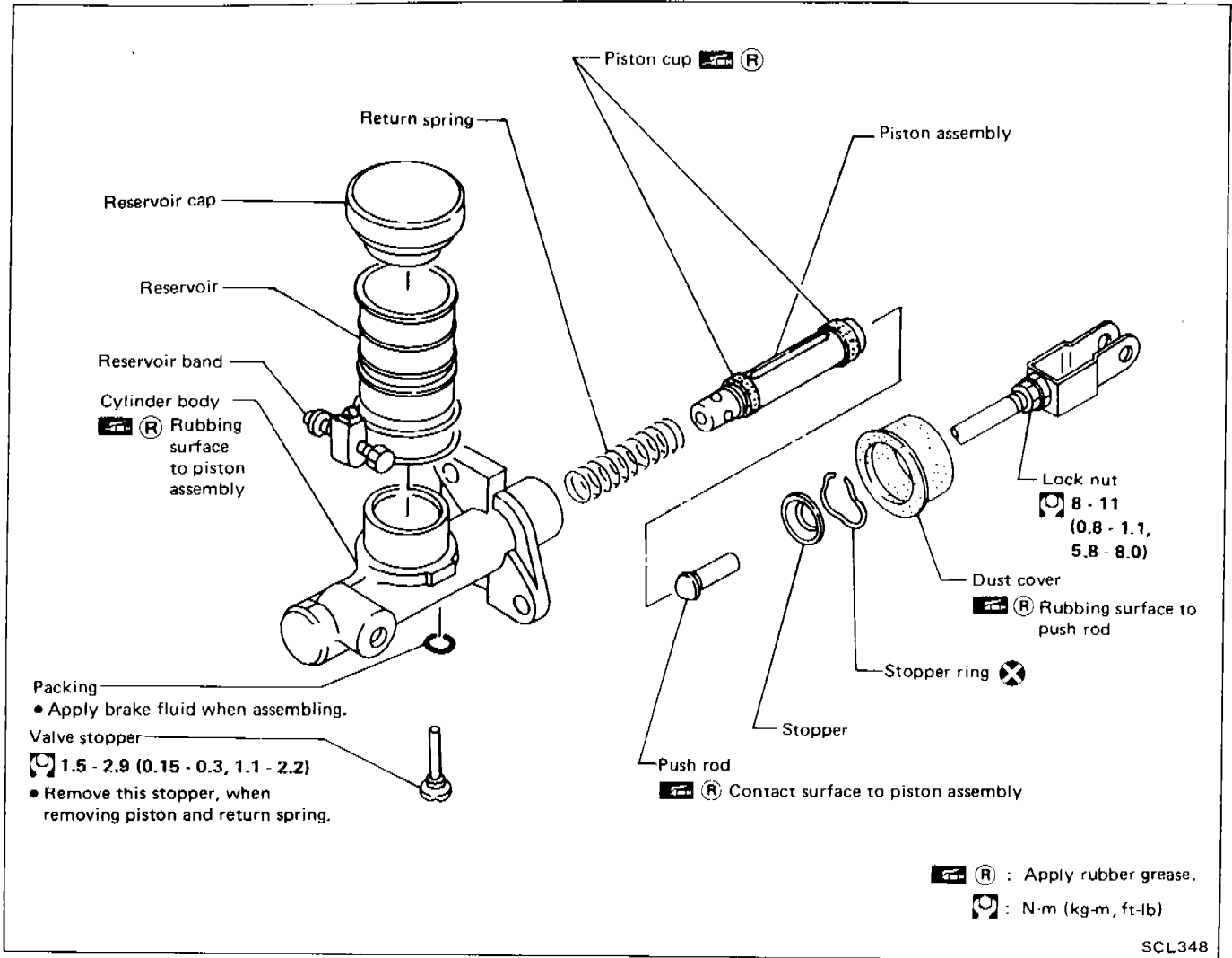

DISASSEMBLY AND ASSEMBLY

- Push piston into cylinder body with screwdriver when removing and installing valve stopper.

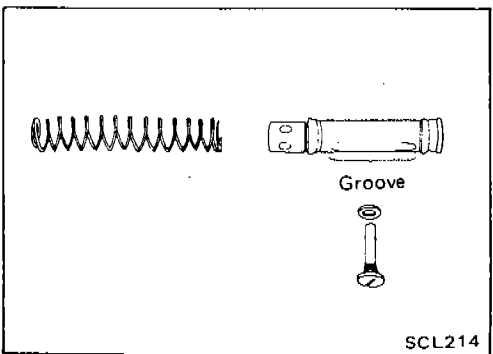

- Align groove of piston assembly and valve stopper when installing valve stopper.
- Check direction of piston cups.

CLUTCH RELEASE MECHANISM

INSPECTION

- Check release bearing to see that it rolls freely and is free from noise, cracks, pitting or wear. Replace if necessary.
- Check release sleeve and withdrawal lever rubbing surface for wear, rust or damage. Replace if necessary.

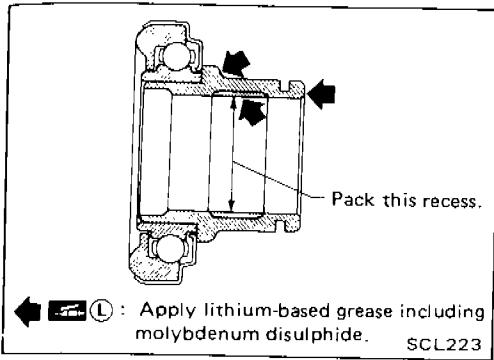

LUBRICATION

- Apply recommended grease to contact surface and rubbing surface.

Too much lubricant might damage clutch disc facing.

CLUTCH RELEASE MECHANISM

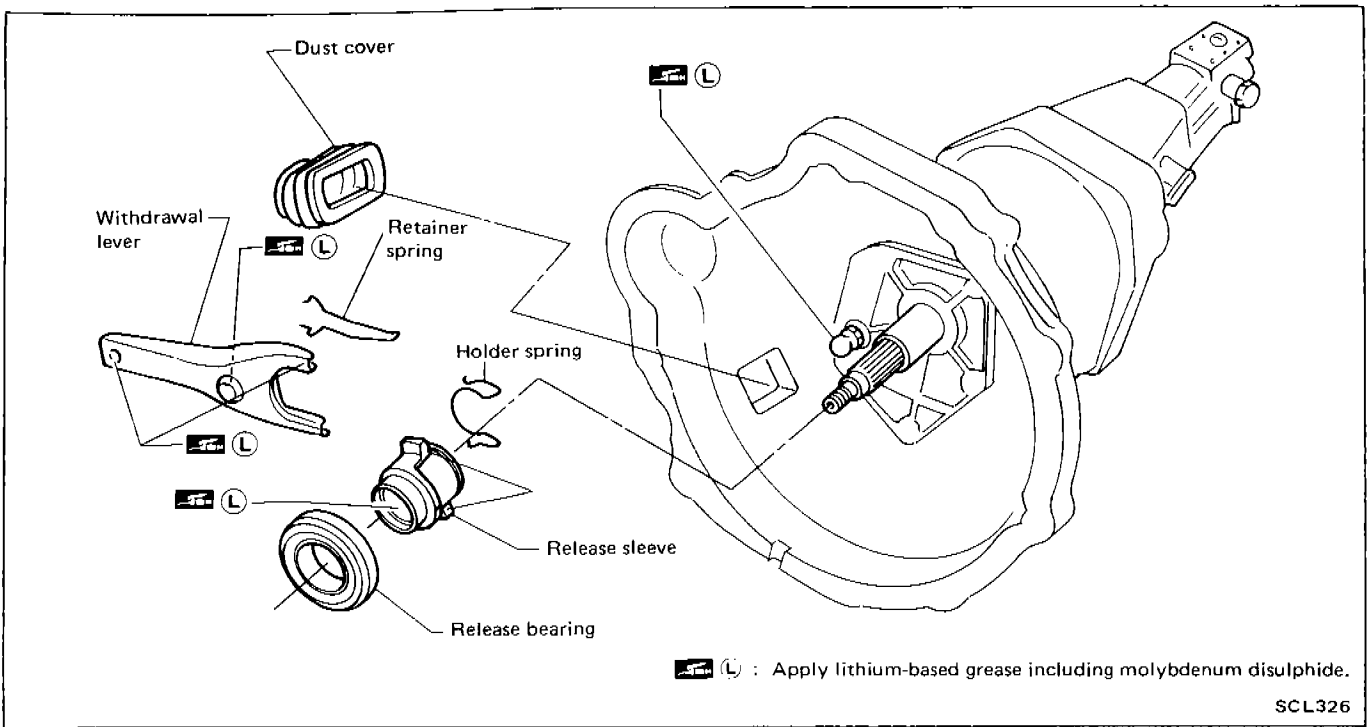

REMOVAL AND INSTALLATION

- Install retainer spring and holder spring.

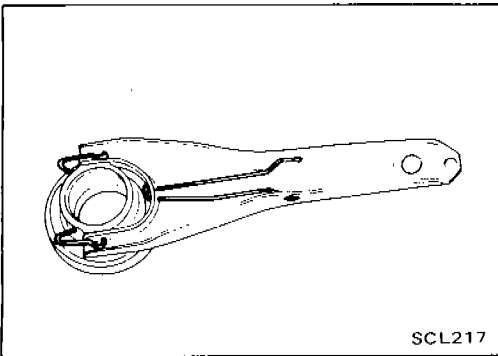

- Remove release bearing.

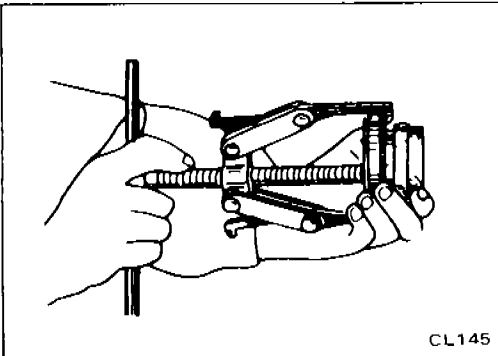

- Install release bearing with suitable drift.

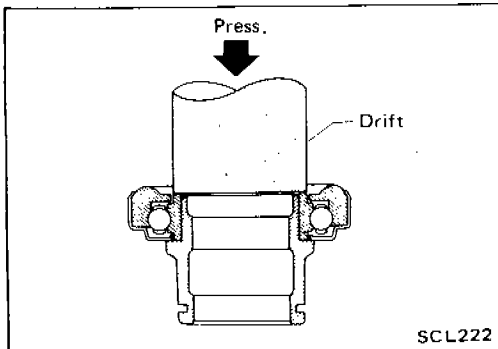

CLUTCH DISC AND CLUTCH COVER

Clutch Cover and Flywheel

INSPECTION AND ADJUSTMENT

- Set Tool and check height and unevenness of diaphragm spring.

Diaphragm spring height "A":

33.0 - 35.0 mm (1.299 - 1.378 in)

- Check thrust rings for wear or damage by shaking cover assembly and listening for chattering noise, or lightly hammering on rivets for a slightly cracked noise. Replace clutch cover assembly if necessary.
- Check pressure plate and clutch disc contact surface for slight burns or discoloration. Repair pressure plate with emery paper.
- Check pressure plate and clutch disc contact surface for deformation or damage. Replace if necessary.

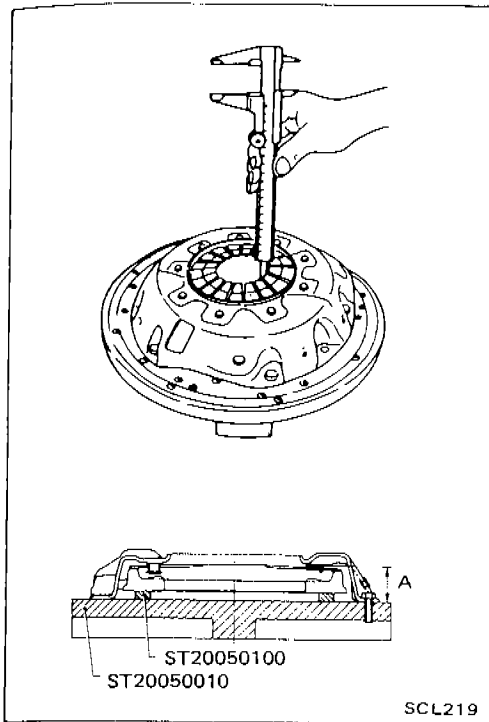

- Adjust unevenness of diaphragm spring with Tool.

Uneven limit:

0.7 mm (0.028 in)

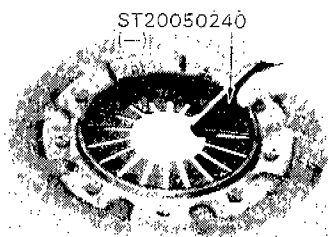

FLYWHEEL INSPECTION

- Check contact surface of flywheel for slight burns or discoloration. Repair flywheel with emery paper.
- Check flywheel runout.

Runout (Total indicator reading):

0.15 mm (0.0059 in) or less

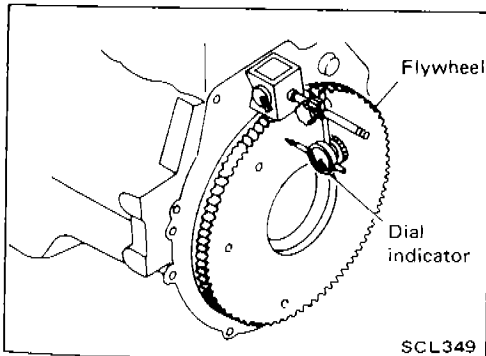

INSTALLATION

- Insert Tool into clutch disc hub when installing clutch cover and disc.

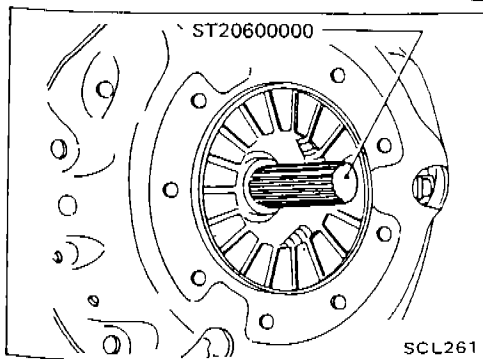

CLUTCH DISC AND CLUTCH COVER

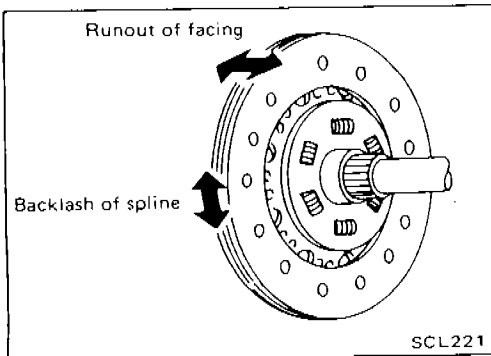
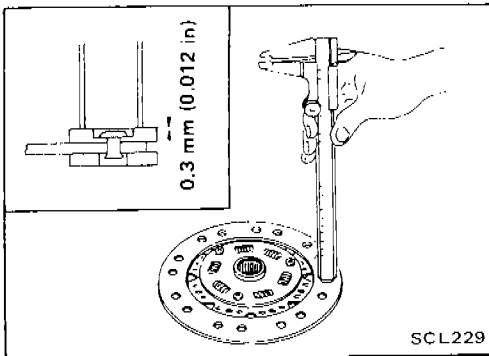
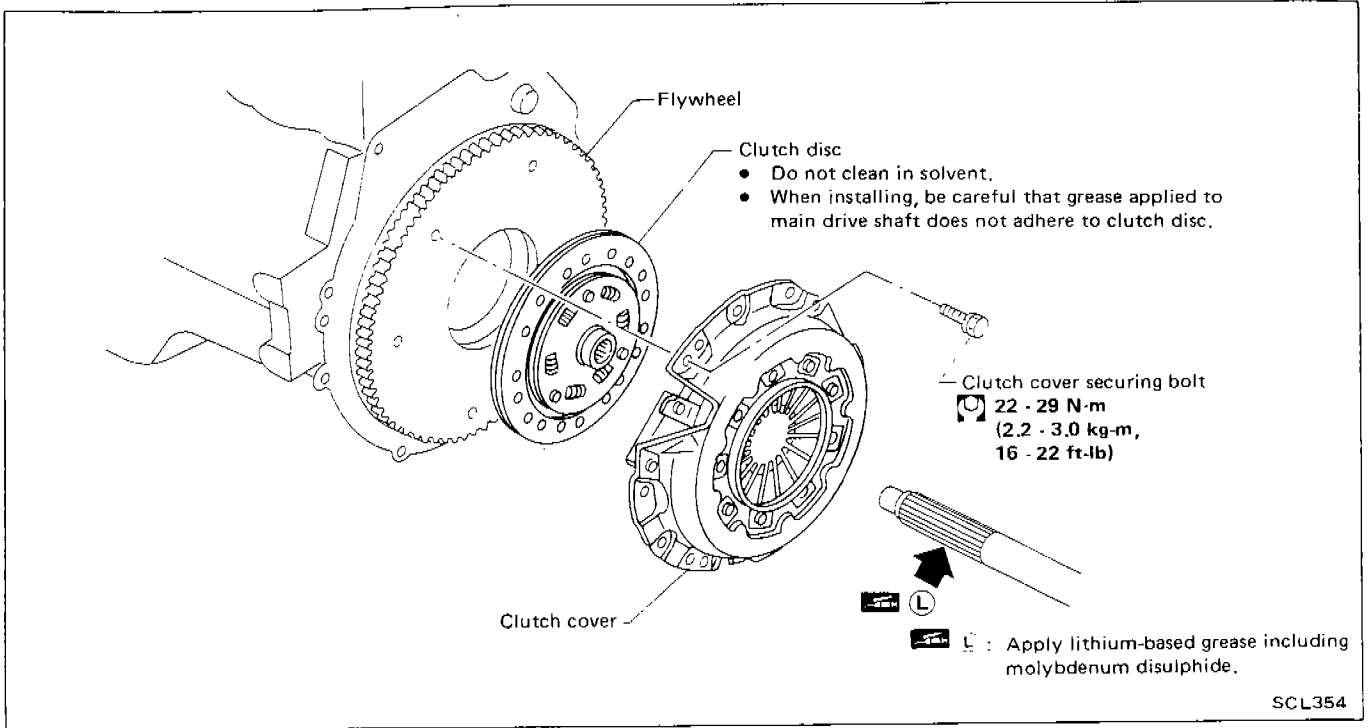

Clutch Disc INSPECTION

- Check clutch disc for wear of facing.
Wear limit of facing surface to rivet head:
0.3 mm (0.012 in)
- Check clutch disc for backlash of spline and runout of facing.
Maximum backlash of spline (at outer edge of disc):
0.9 mm (0.035 in)
Runout limit:
1.0 mm (0.039 in)
Distance of runout check point (from hub center)
107.5 mm (4.23 in)
- Check clutch disc for burns, discoloration or oil or grease leakage. Replace if necessary.

INSTALLATION

- Apply recommended grease to contact surface of spring portion.
- Too much lubricant might damage clutch disc facing.**

MANUAL TRANSMISSION

SECTION **MT**

CONTENTS

| | |
|------------------------------------------------|-------|
| PREPARATION | MT- 2 |
| ON-VEHICLE SERVICE | MT- 4 |
| REMOVAL AND INSTALLATION | MT- 5 |
| MAJOR OVERHAUL | MT- 6 |
| DISASSEMBLY | MT-10 |
| INSPECTION | MT-15 |
| ASSEMBLY | MT-17 |
| SERVICE DATA AND SPECIFICATIONS (S.D.S.) | MT-27 |

MT

SERVICE DATA AND SPECIFICATIONS (S.D.S.)

General Specifications

CLUTCH CONTROL SYSTEM

| | |
|------------------------|-----------|
| Type of clutch control | Hydraulic |
|------------------------|-----------|

CLUTCH MASTER CYLINDER

| | | |
|----------------|---------|-------------|
| Inner diameter | mm (in) | 15.87 (5/8) |
|----------------|---------|-------------|

CLUTCH OPERATING CYLINDER

| | | |
|----------------|---------|-------------|
| Inner diameter | mm (in) | 19.05 (3/4) |
|----------------|---------|-------------|

CLUTCH DISC

| | |
|---------------------------------------------------------|-----------------------------------------------------------------|
| Model | 225LTD |
| Facing size (Outer dia. x inner dia. x thickness) | 225 x 150 x 3.5 (8.86 x 5.91 x 0.138) |
| Thickness of disc assembly With load | 7.6 - 8.0 (0.299 - 0.315) with 5,394 N (550 kg, 1,213 lb) |

CLUTCH COVER

| | |
|-----------|----------------------------------|
| Model | C225S |
| Full load | N (kg, lb) 5,394 (550, 1,213) |

Inspection and Adjustment

CLUTCH PEDAL

Unit: mm (in)

| Model | L.H. | R.H. |
|-----------------------------------------|----------------------------|----------------------------|
| Pedal height* | 186 - 196 (7.32 - 7.72) | 182 - 192 (7.17 - 7.56) |
| Pedal free play (Backlash at clevis) | 1.0 - 3.0 (0.039 - 0.118) | |

*Measured from surface of melt sheet to pedal pad

CLUTCH COVER

Unit: mm (in)

| | |
|------------------------------------------------|-----------------------------|
| Model | C225S |
| Diaphragm spring height | 33.0 - 35.0 (1.299 - 1.378) |
| Uneven limit of diaphragm spring toe height | 0.7 (0.028) |



CLUTCH DISC

Unit: mm (in)

| | |
|---------------------------------------------------------|--------------|
| Model | 225LTD |
| Wear limit of facing surface to rivet head | 0.3 (0.012) |
| Runout limit of facing | 1.0 (0.039) |
| Distance of runout check point (from the hub center) | 107.5 (4.23) |
| Maximum backlash of spline (at outer edge of disc) | 0.9 (0.035) |

PREPARATION

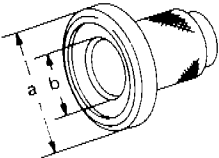
*: Special tool or commercial equivalent

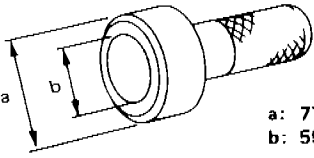
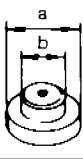
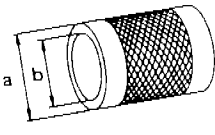
| Tool number Tool name | Description |
|--------------------------|---------------------------------------------------------------------------------------------------------------------------------------------------------------------------------------------------------------------------------------------------------------------------------------------------|
| ST33400001* Drift |  <p style="margin-left: 400px;">a: 60 mm (2.36 in) dia. b: 47 mm (1.85 in) dia.</p> |
| ST33290001* Puller |  <p style="text-align: right;">Removing rear oil seal</p> |
| ST30720000* Drift |  <p style="margin-left: 400px;">a: 77 mm (3.03 in) dia. b: 55.5 mm (2.185 in) dia.</p> |
| ST30613000* Drift |  <p style="margin-left: 400px;">a: 71.5 mm (2.815 in) dia. b: 47.5 mm (1.870 in) dia.</p> |
| ST33200000* Drift |  <p style="margin-left: 400px;">a: 60 mm (2.36 in) dia. b: 44.5 mm (1.752 in) dia.</p> <p style="text-align: right;">Installing counter rear bearing Installing 3rd & 4th synchronizer assembly</p> |

COMMERCIAL SERVICE TOOL

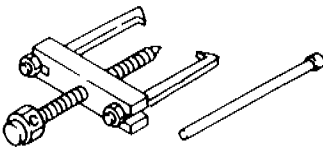
| Tool name | Description |
|-----------|-------------------------------------------------------------------------------------------------------------------------------------------------------------------------------|
| Puller |  <p style="text-align: right;">Removing counter bearings, counter drive and O.D. gears</p> |

PREPARATION

SPECIAL SERVICE TOOLS

*: Special tool or commercial equivalent

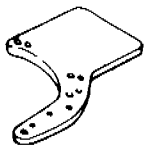
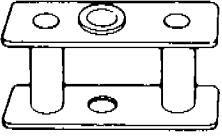
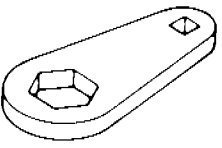
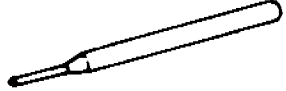
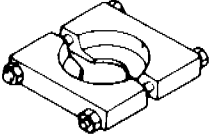
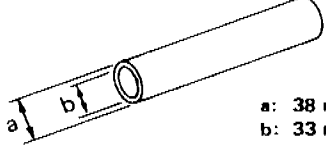
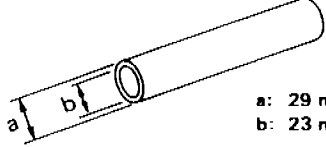
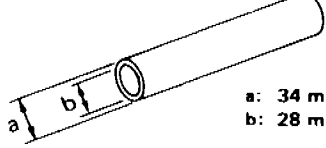
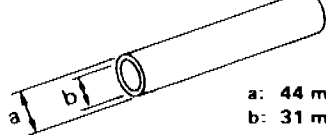
| Tool number Tool name | Description |
|----------------------------------------|-----------------------------------------------------------------------------------------------------------------------------------------------------------------------------------------------------------------------------------------------------------------|
| ST23810001 Adapter setting plate |  <p style="text-align: right;">Fixing adapter plate with gear assembly</p> |
| KV31100401 Transmission press stand |  <p style="text-align: right;">Pressing counter gear and mainshaft</p> |
| ST22520000 Wrench |  <p style="text-align: right;">Tightening mainshaft lock nut</p> |
| ST23540000* Pin punch |  <p style="text-align: right;">Removing and installing fork rod retaining pin</p> |
| ST30031000* Puller |  <p style="text-align: right;">Removing and installing 1st gear bushing Removing main drive gear bearing Measuring wear of baulk rings</p> |
| ST23860000* Drift |  <p style="text-align: right;">Installing counter drive gear</p> <p style="text-align: right;">a: 38 mm (1.50 in) dia. b: 33 mm (1.30 in) dia.</p> |
| ST22360002* Drift |  <p style="text-align: right;">Installing counter gear front and rear end bearings</p> <p style="text-align: right;">a: 29 mm (1.14 in) dia. b: 23 mm (0.91 in) dia.</p> |
| ST22350000* Drift |  <p style="text-align: right;">Installing O.D. gear bushing</p> <p style="text-align: right;">a: 34 mm (1.34 in) dia. b: 28 mm (1.10 in) dia.</p> |
| ST23800000* Drift |  <p style="text-align: right;">Installing front cover oil seal</p> <p style="text-align: right;">a: 44 mm (1.73 in) dia. b: 31 mm (1.22 in) dia.</p> |

REMOVAL AND INSTALLATION

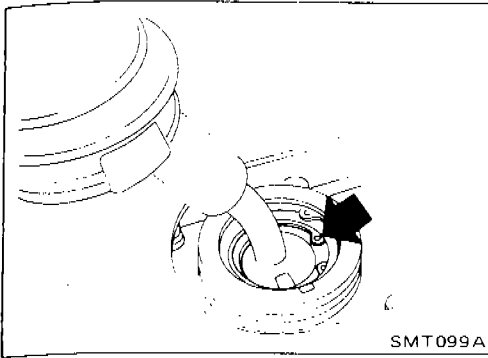

Removal

- Remove shift lever.

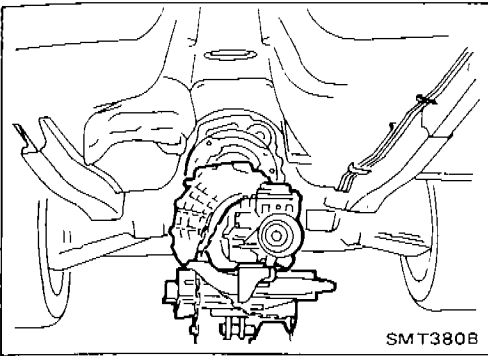

- Remove propeller shaft. — Refer to section PD.
- Insert plug into rear oil seal after removing propeller shaft.
- Be careful not to damage spline, sleeve yoke and rear oil seal, when removing propeller shaft.
- Support engine by placing a jack under oil pan.
- Do not place jack under oil pan drain plug.
- Remove transmission from engine.
- Support manual transmission, while removing it.

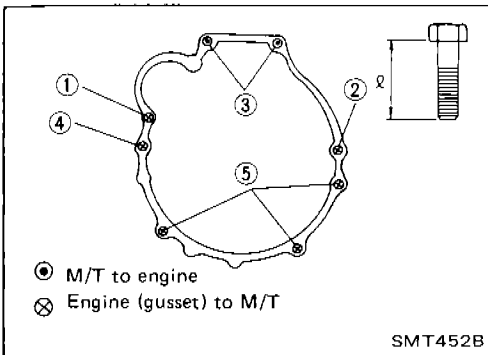

Installation

- Tighten all transmission bolts.

| Bolt No. | Tightening torque N·m (kg·m, ft·lb) | ℓ mm (in) |
|------------------|-------------------------------------|-----------|
| 1 | 39 - 49 (4.0 - 5.0, 29 - 36) | 80 (3.15) |
| 2 | 39 - 49 (4.0 - 5.0, 29 - 36) | 75 (2.95) |
| 3 | 39 - 49 (4.0 - 5.0, 29 - 36) | 65 (2.56) |
| 4 | 29 - 39 (3.0 - 4.0, 22 - 29) | 40 (1.57) |
| 5 | 29 - 39 (3.0 - 4.0, 22 - 29) | 25 (0.98) |
| Gusset to engine | 29 - 39 (3.0 - 4.0, 22 - 29) | 20 (0.79) |

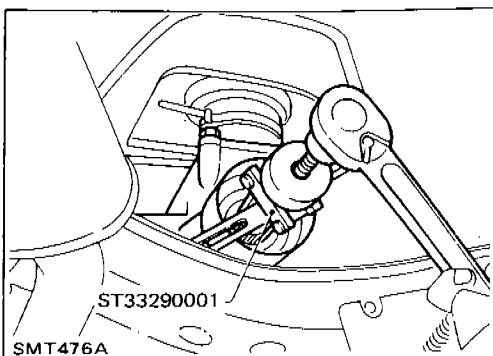

Replacing Rear Oil Seal
REMOVAL

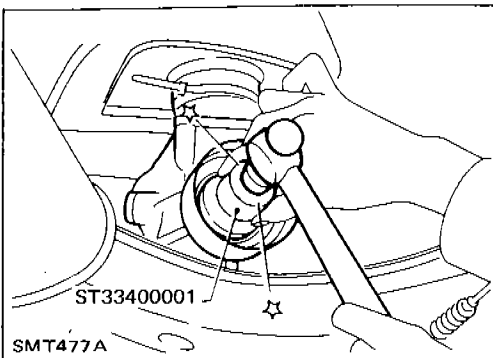

INSTALLATION

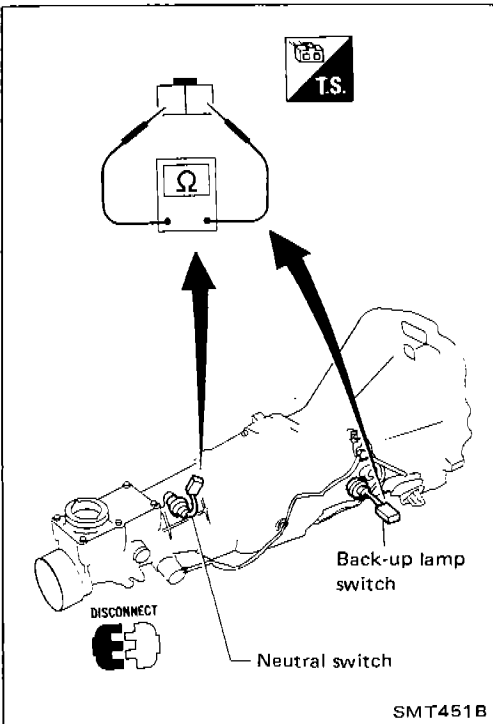

Check of Position Switch

BACK-UP LAMP SWITCH

- Check continuity.

| Gear position | Continuity |
|----------------|------------|
| Reverse | Yes |
| Except reverse | No |

NEUTRAL SWITCH

- Check continuity.

| Gear position | Continuity |
|----------------|------------|
| Neutral | Yes |
| Except neutral | No |

MAJOR OVERHAUL

Gear Components

FOR EUROPE

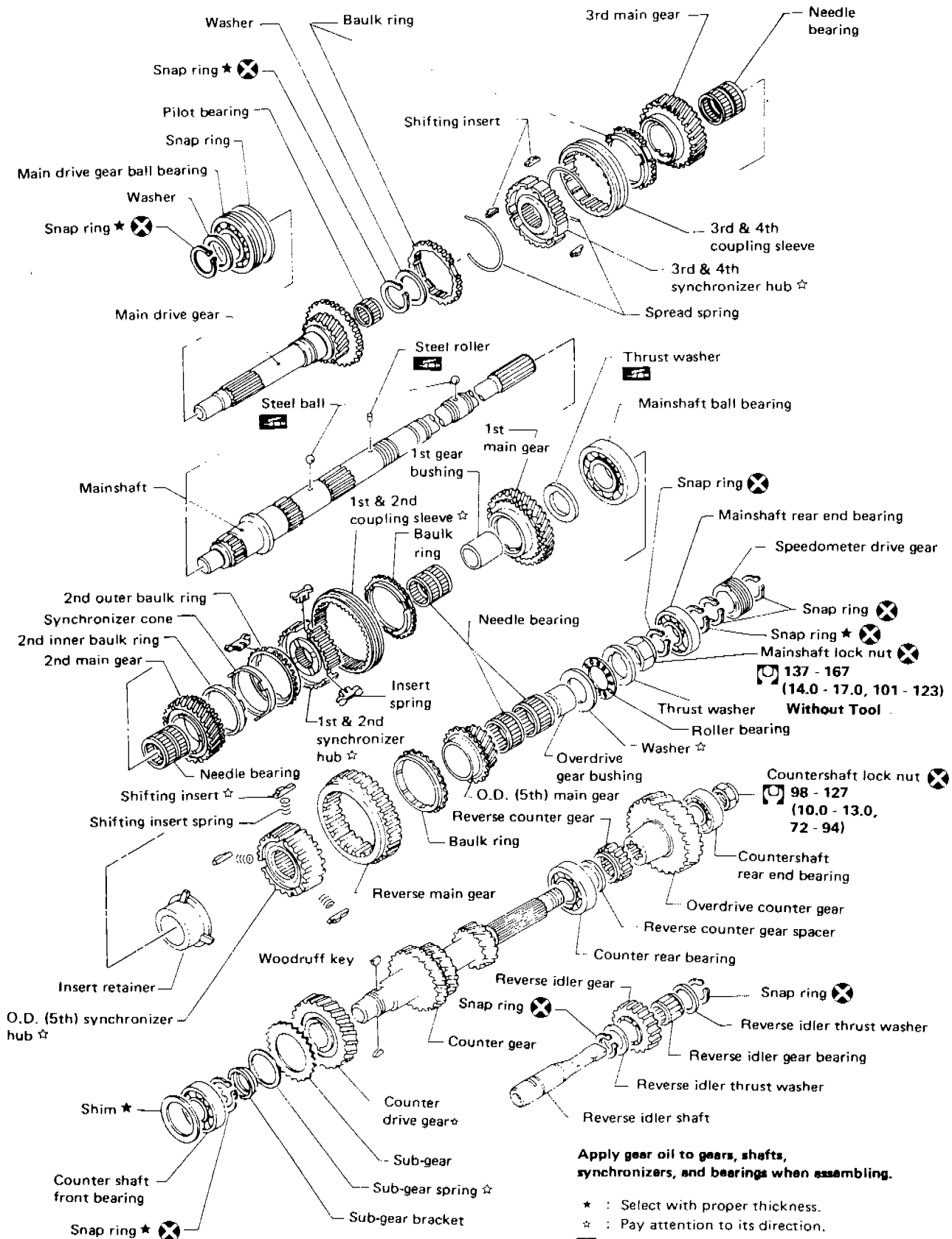

SMT037B

MT-7

MAJOR OVERHAUL

Case Components

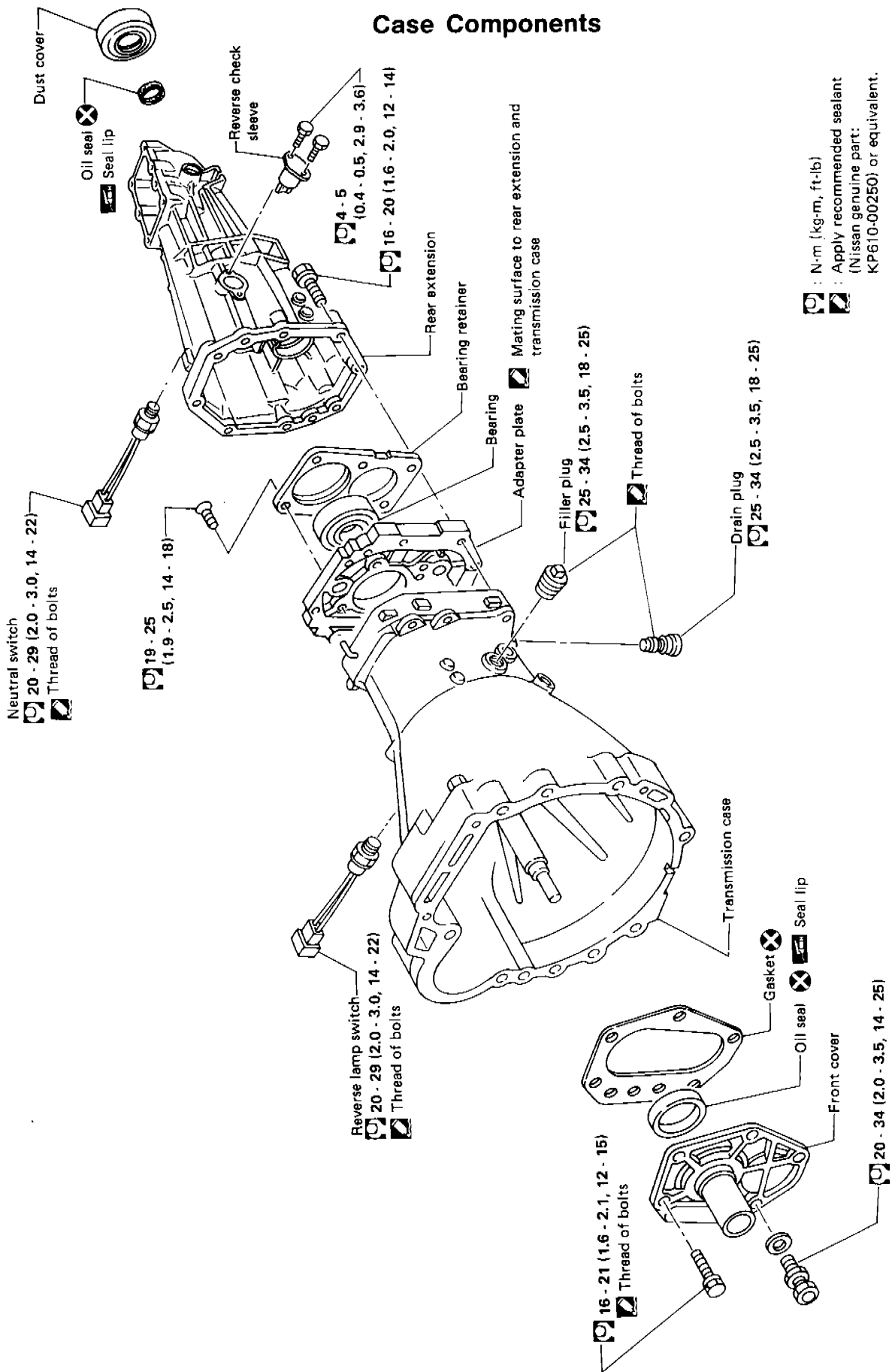

: N·m (kg·m, ft·lb)
 : Apply recommended sealant (Nissan genuine part: KP610-00250) or equivalent.

MT-6

SMT746A

DISASSEMBLY

Shift Control Components

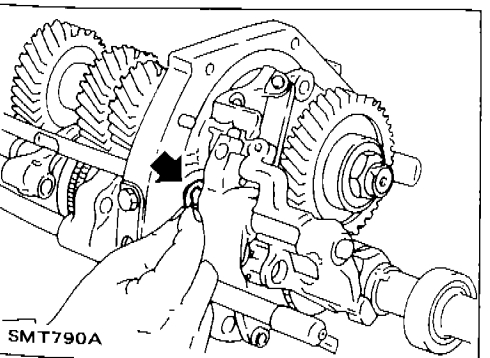
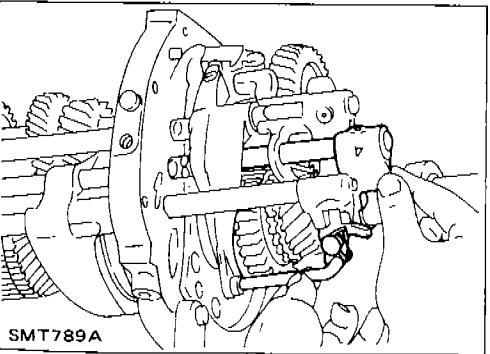
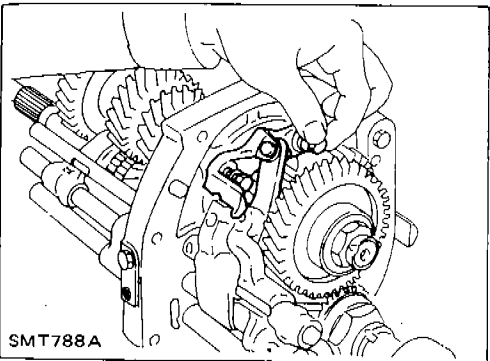
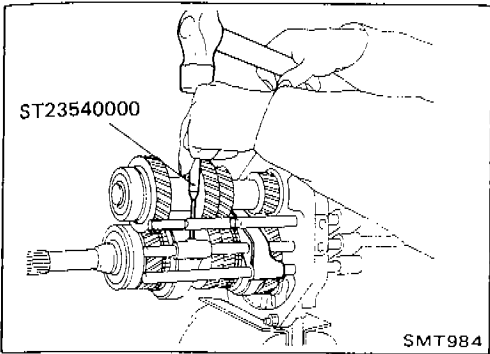
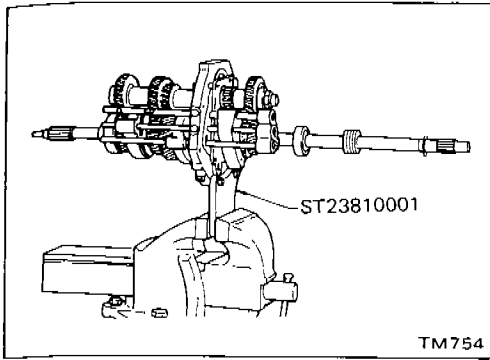

1. Set up Tool on adapter plate.
2. Remove check ball plugs, check springs, and check balls.
3. Drive out retaining pins. Then drive out fork rods and remove interlock balls.
4. Remove lever bracket securing bolt.
5. Draw out 3rd-4th fork rod.
6. Remove E-ring from O.D. and reverse fork rod.

DISASSEMBLY

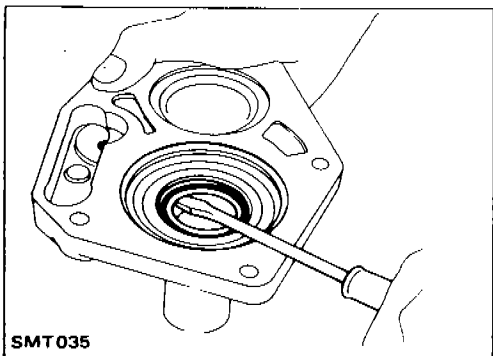
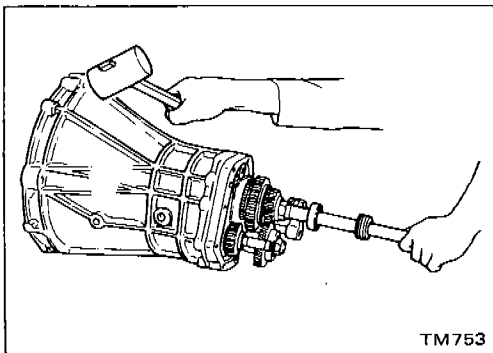
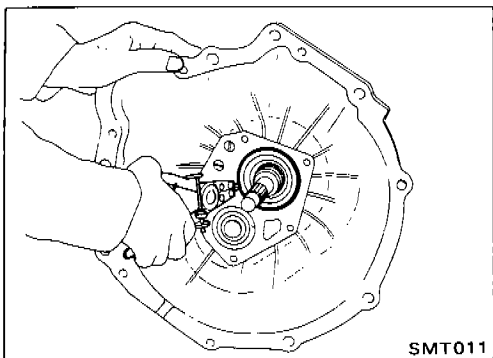
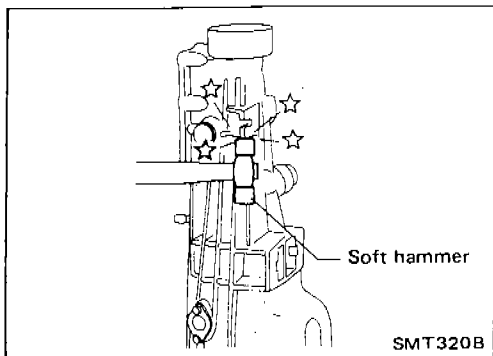
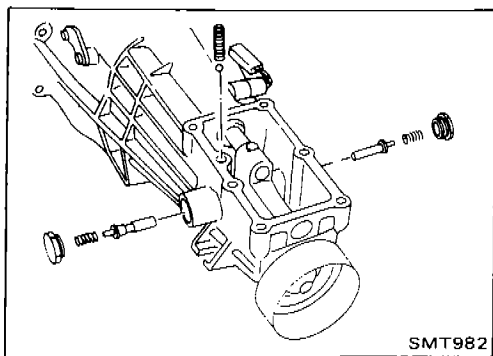

Case Components

1. Remove rear extension.
 - a. Remove control housing, check ball, return spring plug, select check plunger and return springs.
 - b. Remove rear extension by lightly tapping it.
2. Remove front cover, gasket, shim of countershaft front bearing, and snap ring of main drive gear ball bearing.
3. Remove transmission case by tapping lightly.
4. Remove front cover oil seal.

DISASSEMBLY

Gear Components (Cont'd)

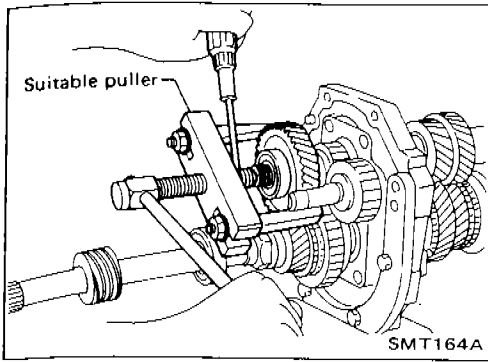

- b. Pull out O.D. counter gear with bearing with suitable puller.
- c. Draw out reverse counter gear and spacer.
- d. Remove snap rings from reverse idler shaft and draw out reverse idler gear, thrust washers and reverse idler gear bearing.
- e. Remove speedometer drive gear and steel ball.

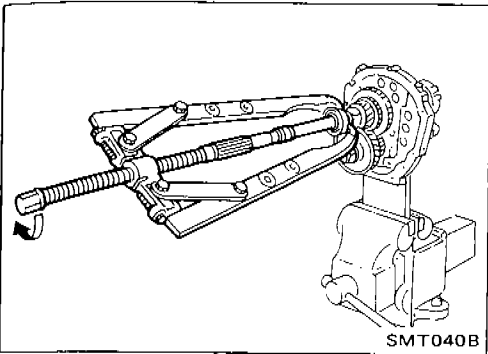

- f. Remove snap ring and pull out overdrive mainshaft bearing, then remove snap ring.
- g. Remove mainshaft nut.
- h. Remove steel roller and washer.
- i. Remove roller bearing and washer.
- j. Remove O.D. main gear, needle bearing and baulk ring (O.D.).
- k. Remove O.D. coupling sleeve, shifting inserts and shifting insert springs.

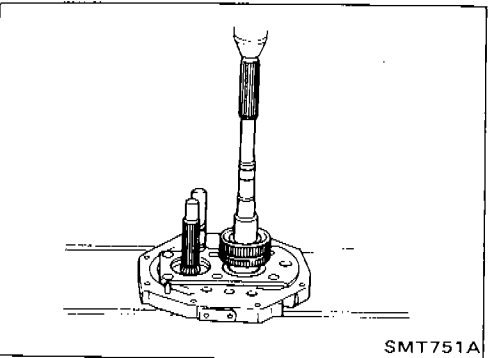

- l. Press out mainshaft and counter gear alternately.
 - **Make sure to alternate pressing of mainshaft and counter gear so as not to allow the front surface of one to contact the rear surface of the other.**

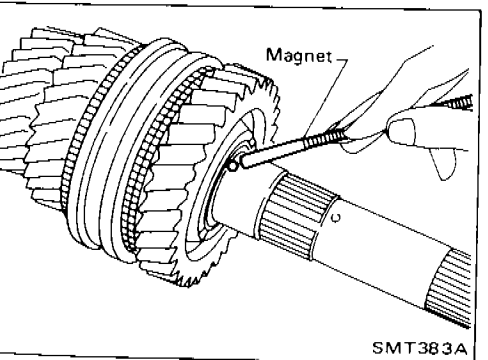

6. Remove front side components on mainshaft.
 - a. Remove 1st gear washer and steel ball.
 - b. Remove 1st main gear and 1st gear needle bearing.

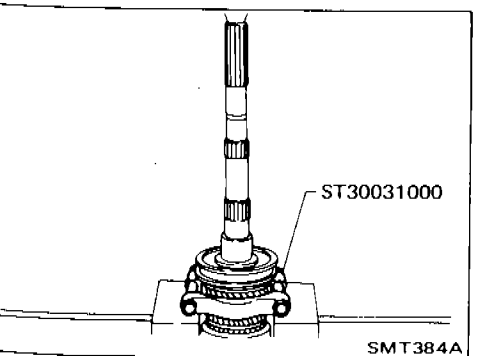

- c. Press out 2nd main gear together with 1st gear bushing and 1st & 2nd synchronizer assembly.
- d. Remove mainshaft front snap ring.

DISASSEMBLY

Shift Control Components (Cont'd)

7. Draw out O.D. and reverse fork shaft by rotating O.D. and reverse bracket counterclockwise.

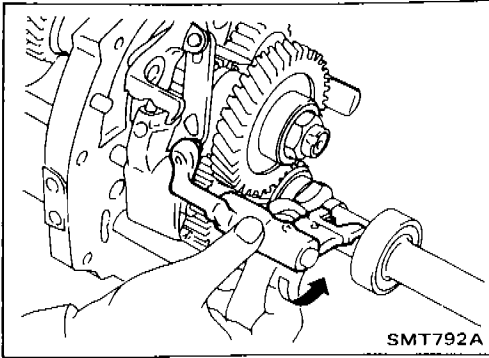

Gear Components

1. Before removing gears and shafts, measure each gear end play.

Gear end play: Refer to S.D.S.

If not within specification, disassemble and check contact surface of gear to hub, washer, bushing, needle bearing and shaft.

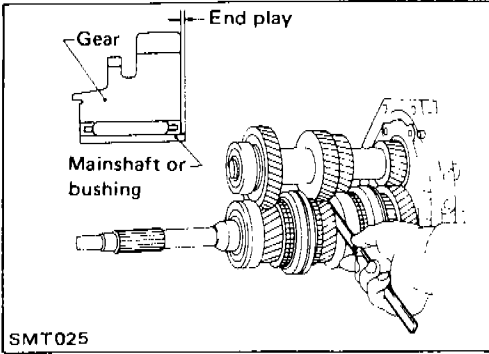

2. Mesh 2nd and reverse gear, then draw out counter front bearing with suitable puller.
3. Remove snap ring and then remove sub-gear bracket, sub-gear spring and sub-gear.

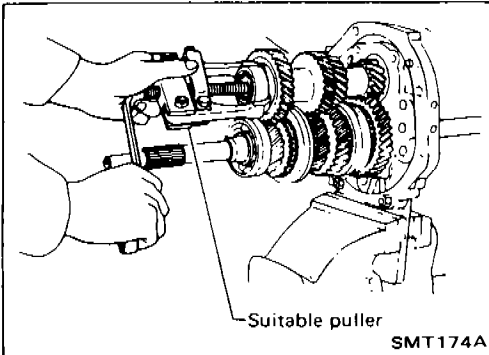

4. Draw out counter drive gear with main drive gear assembly with suitable puller.

- When drawing out main drive gear assembly, be careful not to drop pilot bearing and baulk ring.

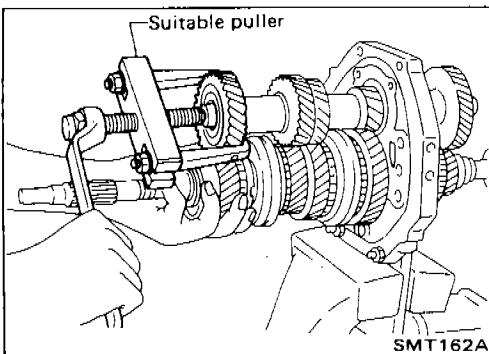

5. Remove rear side components on mainshaft and counter gear.

- a. Release staking on countershaft nut and mainshaft nut and loosen these nuts.

Mainshaft nut: Left-hand thread

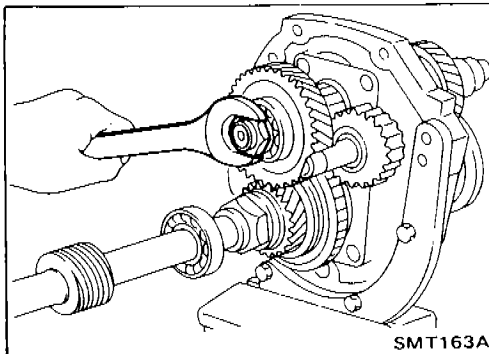

INSPECTION

Shift Control Components

- Check contact surface and sliding surface for wear, scratches, projections or other damage.

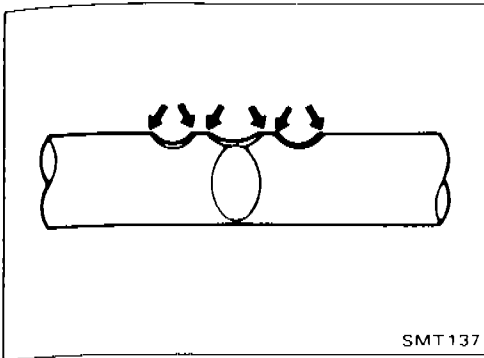

Gear Components

GEAR AND SHAFT

- Check shafts for cracks, wear or bending.
- Check gears for excessive wear, chips or cracks.

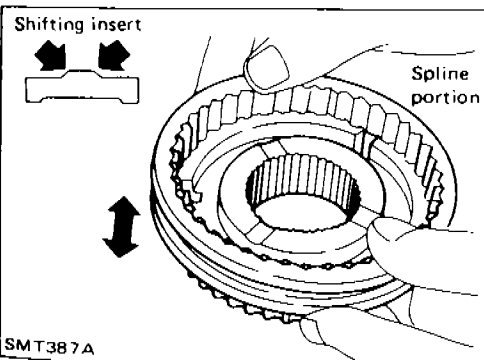
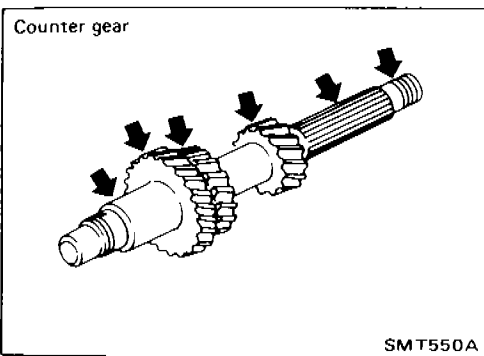
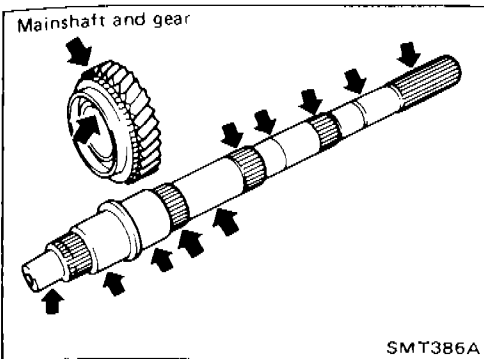

SYNCHRONIZERS

- Check spline portion of coupling sleeves, hubs and gears for wear or cracks.
- Check baulk rings for cracks or deformation.
- Check shifting inserts for wear or deformation.
- Check insert springs for deformation.

DISASSEMBLY

Gear Components (Cont'd)

- e. Press out 3rd main gear together with 3rd & 4th synchronizer assembly and 3rd gear needle bearing.

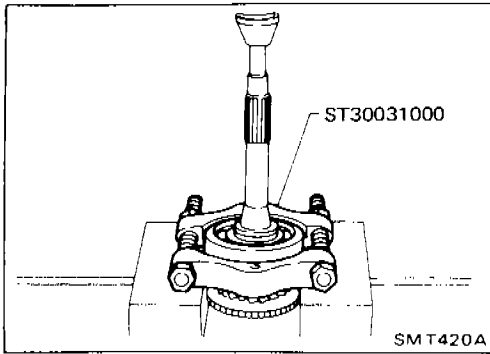
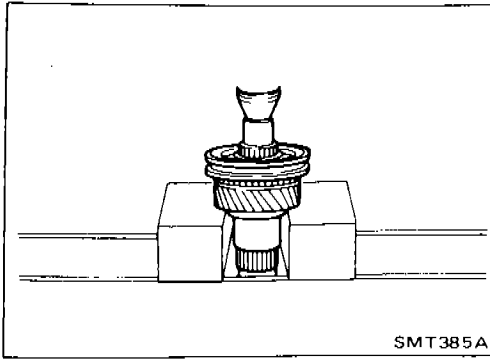

7. Remove main drive gear bearing.
 - a. Remove main drive gear snap ring and spacer.
 - b. Press out main drive gear bearing.

ASSEMBLY

Gear Components

1. Install bearings into case components.

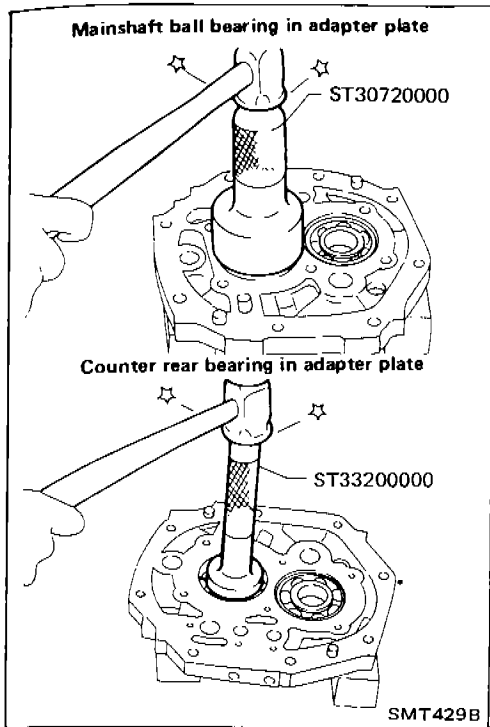

2. Assemble adapter plate parts.

- Install oil gutter on adapter plate and expand on rear side.

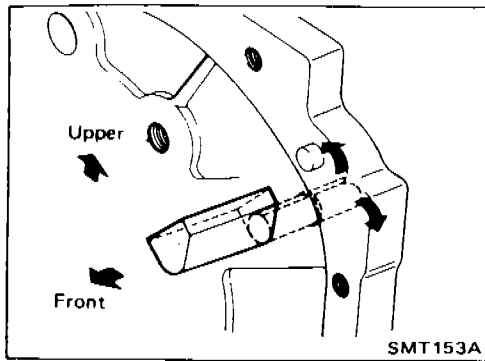

- Install bearing retainer.

- a. Insert reverse shaft, then install bearing retainer.

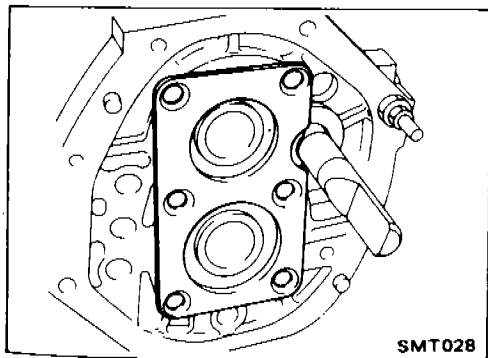

- b. Tighten each screw, then stake each at two points.

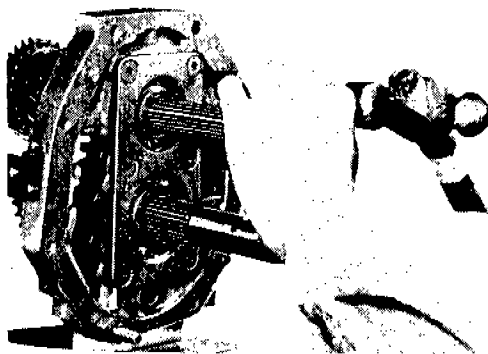

INSPECTION

Gear Components (Cont'd)

- Measure clearance between baulk ring and gear.
- Clearance between baulk ring and gear**
[1st, 3rd, main drive and O.D. baulk ring (For Europe), 1st, main drive and O.D. baulk ring (Except for Europe)]:

Unit: mm (in)

| Dimension | Standard | Wear limit |
|--------------------|------------------------------|-------------|
| 1st | 1.2 - 1.6 (0.047 - 0.063) | 0.8 (0.031) |
| 3rd and main drive | 1.2 - 1.6 (0.047 - 0.063) | |
| O.D. | 1.2 - 1.4 (0.047 - 0.055) | |

If the clearance is smaller than the wear limit, replace baulk ring.

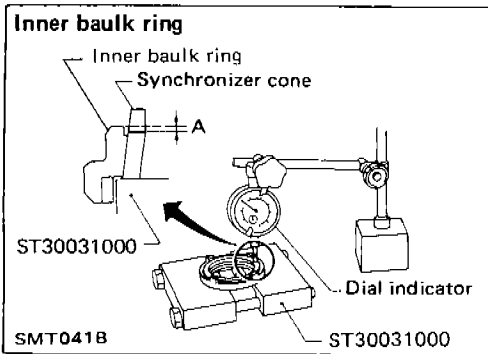
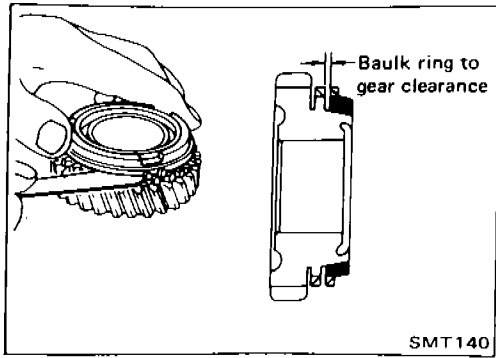

- Measure wear of baulk ring.
- [2nd baulk ring (For Europe), 2nd and 3rd baulk ring (Except for Europe)]**
- Place baulk rings in position on synchronizer cone.
 - While holding baulk rings against synchronizer cone as far as it will go, measure dimensions "A" and "B".

Unit: mm (in)

| Dimension | Standard | Wear limit |
|-----------|------------------------------|-------------|
| A | 0.6 - 1.1 (0.024 - 0.043) | 0.2 (0.008) |
| B | 0.7 - 0.9 (0.028 - 0.035) | |

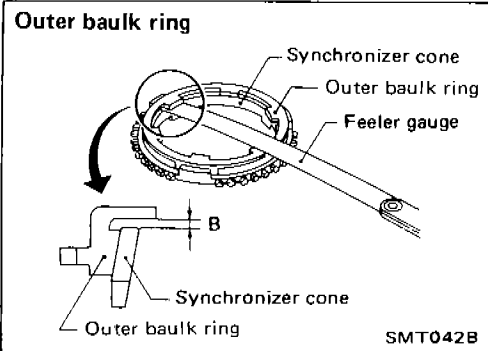

- If dimension "A" or "B" is smaller than the wear limit, replace baulk ring.

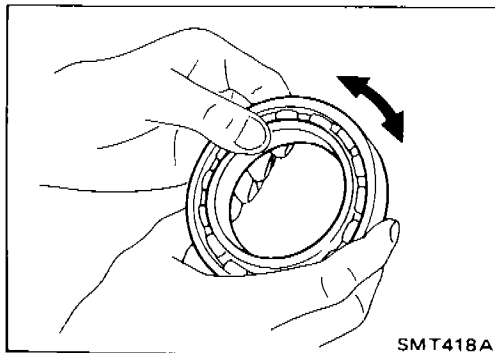

BEARINGS

- Make sure bearings roll freely and are free from noise, crack, pitting or wear.

ASSEMBLY

Gear Components (Cont'd)

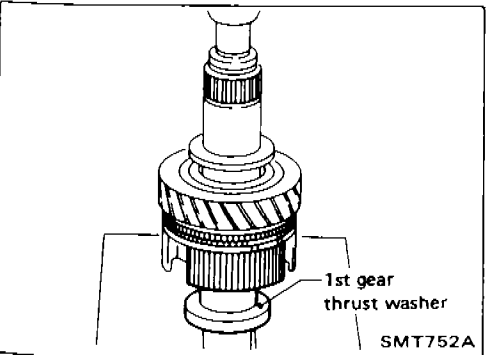
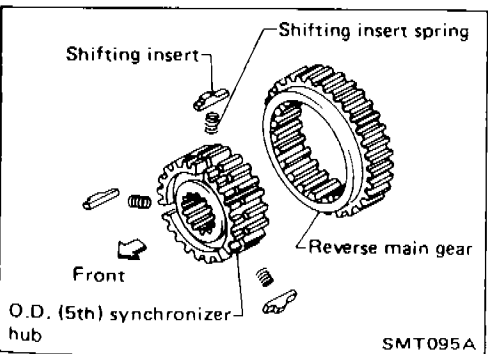
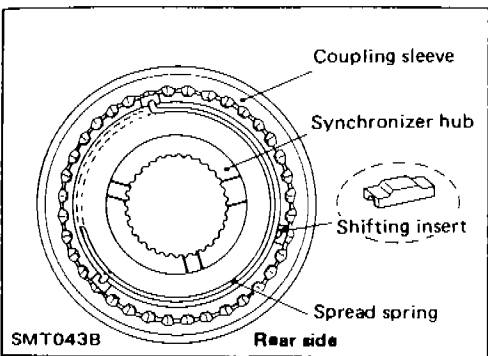
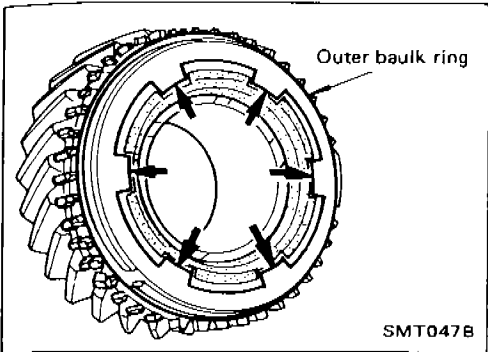
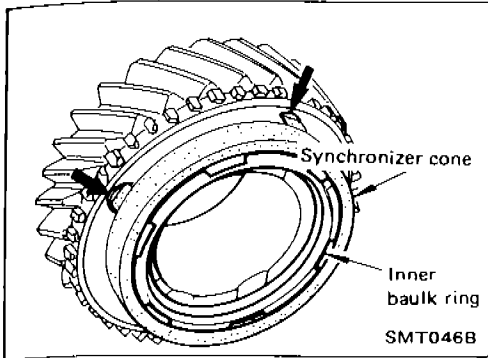

● 3rd & 4th synchronizer

● O.D. synchronizer

5. Install front side components on main shaft.
 - a. Assemble 2nd main gear, needle bearing and 1st & 2nd synchronizer assembly, then press 1st gear bushing on mainshaft.
 - b. Install 1st main gear.

ASSEMBLY

Gear Components (Cont'd)

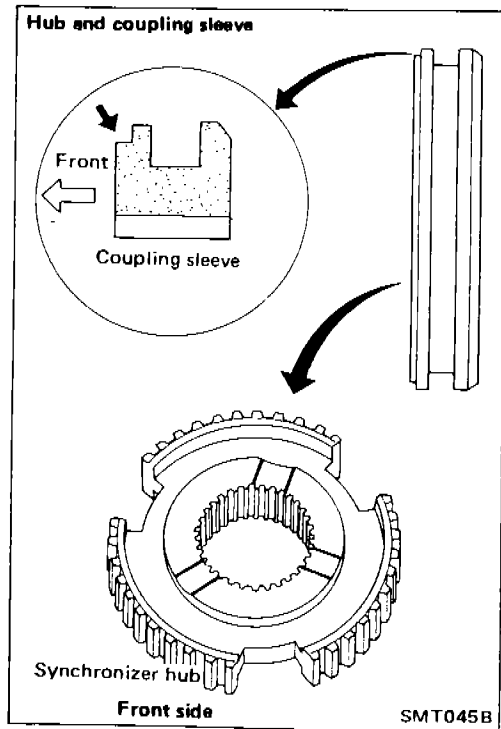
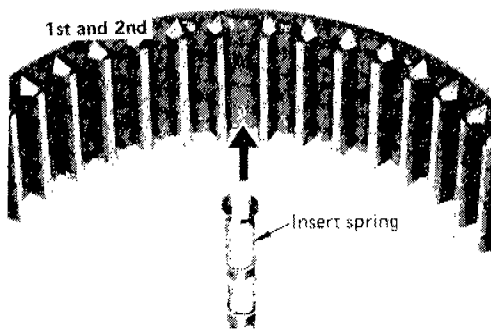
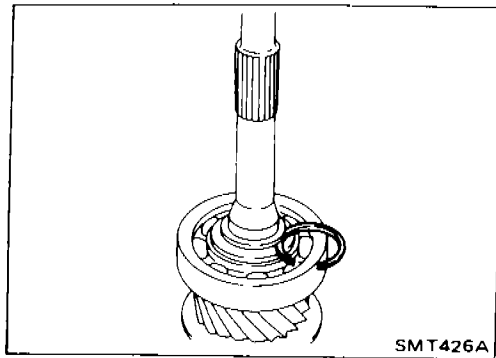
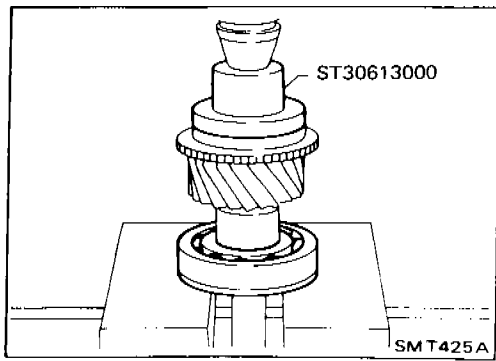

3. Install main drive gear bearing.
 - a. Press main drive gear bearing.
 - b. Install main drive gear spacer.

- c. Select proper main drive gear snap ring to minimize clearance of groove and install it.

Allowable clearance of groove:

0 - 0.13 mm (0 - 0.0051 in)

Main drive gear snap ring:

Refer to S.D.S.

4. Assemble synchronizers.

- 1st & 2nd synchronizer

- Check coupling sleeve and synchronizer hub orientation.

ASSEMBLY

Gear Components (Cont'd)

f. Press counter drive gear with main drive gear with Tool.

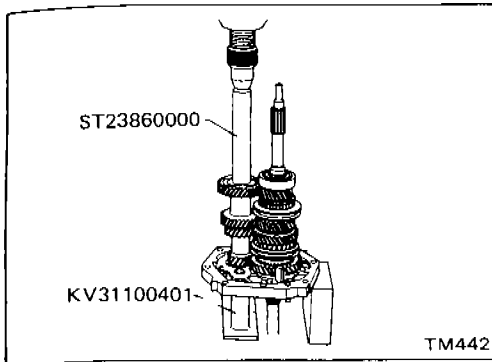

● Pay attention to direction of counter drive gear.

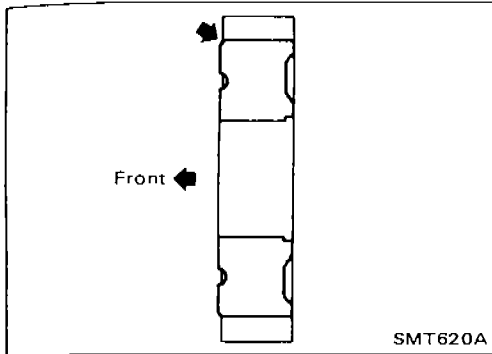

g. Install sub-gear components.

(1) Install sub-gear and sub-gear bracket on counter drive gear and then select proper snap ring to minimize clearance of groove in counter gear.

Allowable clearance of groove:

0 - 0.18 mm (0 - 0.0071 in)

Counter drive gear snap ring: Refer to S.D.S.

(2) Remove snap ring, sub-gear bracket and sub-gear from counter gear.

(3) Reinstall sub-gear, sub-gear spring and sub-gear bracket.

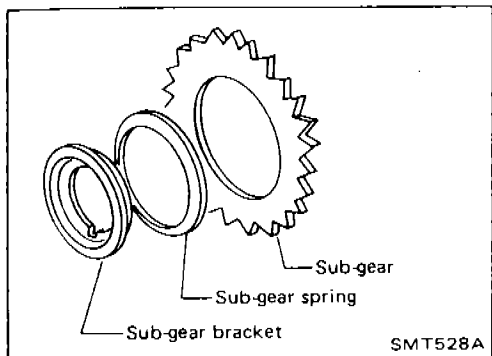

h. Install selected counter drive gear snap ring.

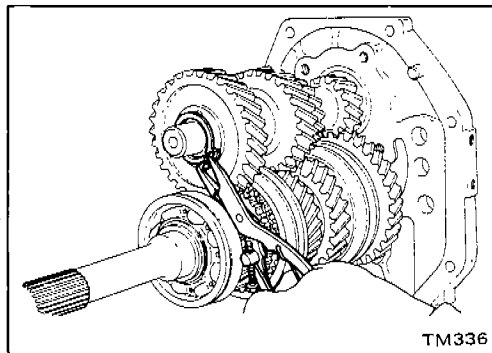

i. Press counter gear front bearing onto counter gear.

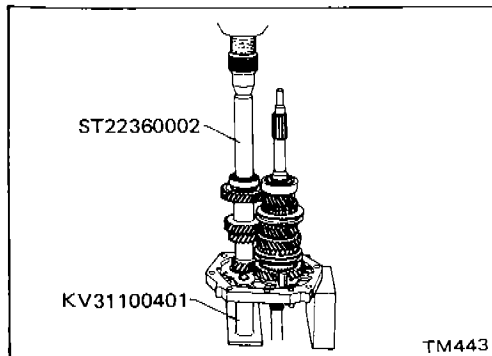

ASSEMBLY

Gear Components (Cont'd)

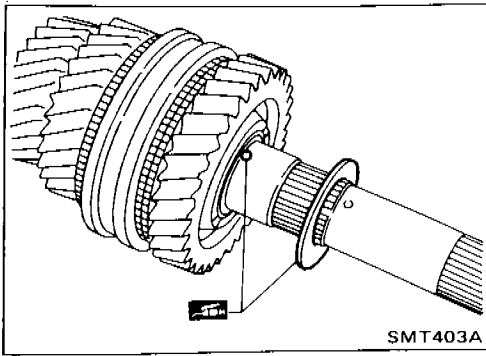

- c. Install steel ball and 1st gear washer.
 ● Apply multi-purpose grease to steel ball and 1st gear washer before installing.

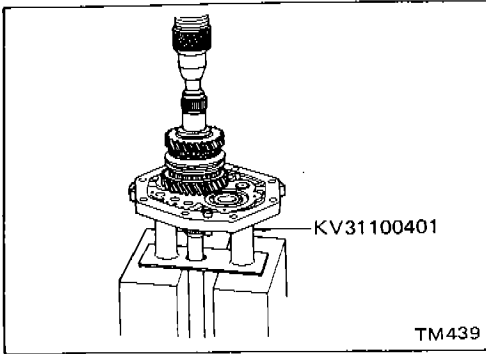

6. Install mainshaft and counter gear on adapter plate and main drive gear on mainshaft.
 a. Press mainshaft assembly to adapter plate with Tool.

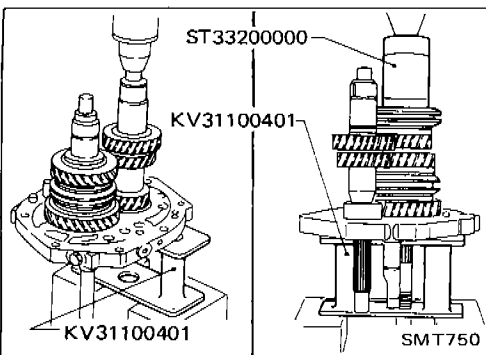

- b. Press counter gear into adapter plate with Tool.
 c. Install 3rd main gear and then press 3rd & 4th synchronizer assembly.

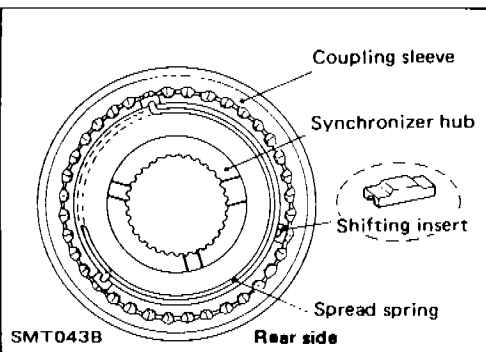

- Pay attention to direction of 3rd & 4th synchronizer.

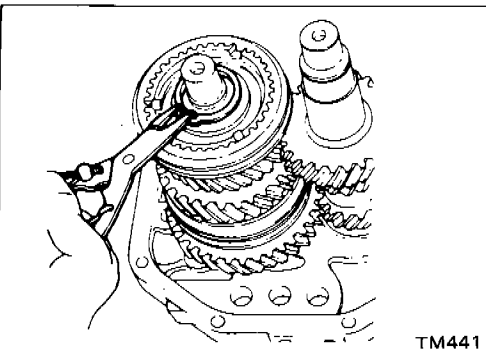

- d. Install thrust washer on mainshaft and secure it with mainshaft front snap ring. Select proper snap ring to minimize clearance of groove in mainshaft.

Allowable clearance of groove:

0 - 0.18 mm (0 - 0.0071 in)

Mainshaft front snap ring:

Refer to S.D.S.

- e. Apply gear oil to mainshaft pilot bearing and install it on mainshaft.

ASSEMBLY

Gear Components (Cont'd)

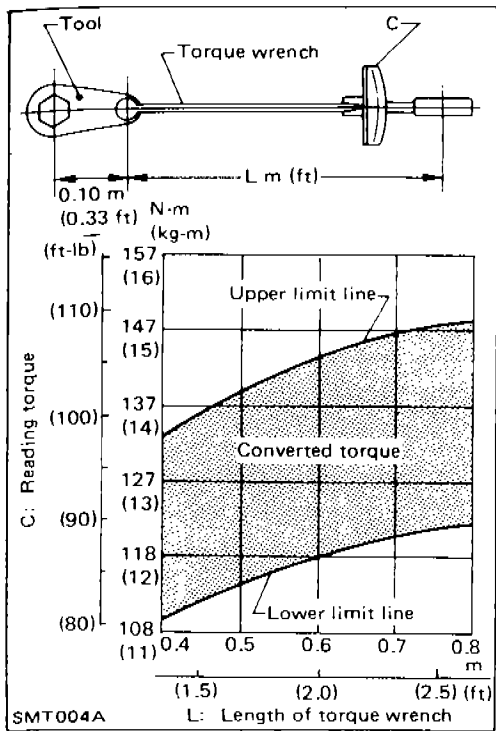

- Use the left chart when deciding the reading torque. (Length of torque wrench vs. setting or reading torque)
9. Tighten countershaft lock nut.
 - **Always use new lock nut.**

Mainshaft

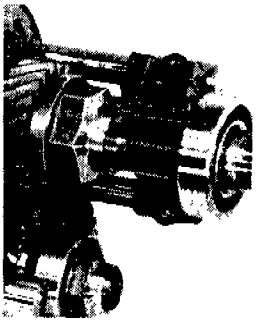

Countershaft

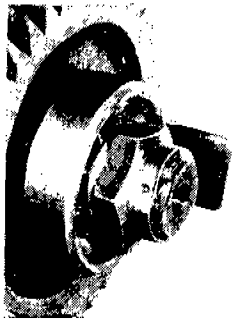

10. Stake mainshaft lock nut and countershaft lock nut with a punch.
11. Measure gear end play. For the description, refer to DIS-ASSEMBLY for Gear Components.

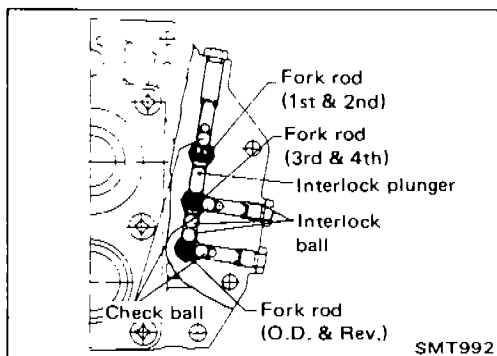

Shift Control Components

1. Install shift rods, interlock plunger, interlock balls and check balls.

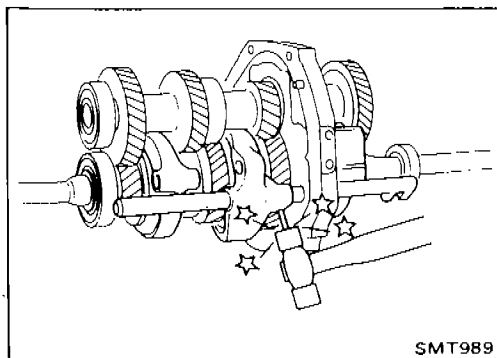

- a. 1st-2nd shift fork

ASSEMBLY

Gear Components (Cont'd)

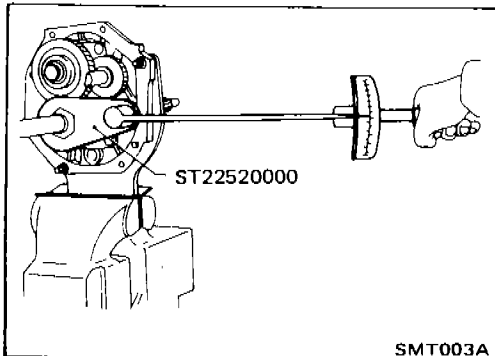
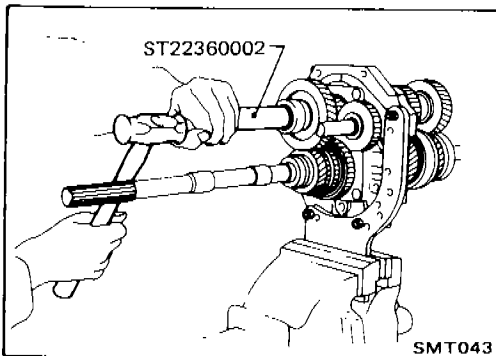
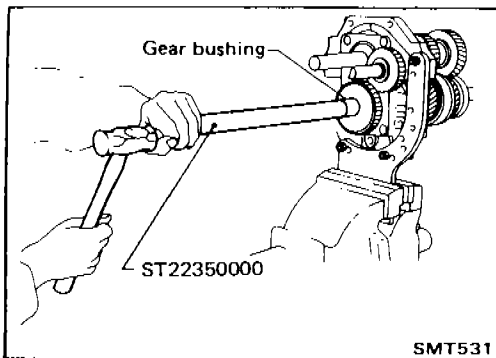
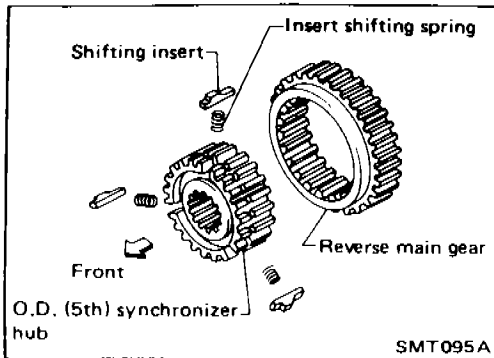
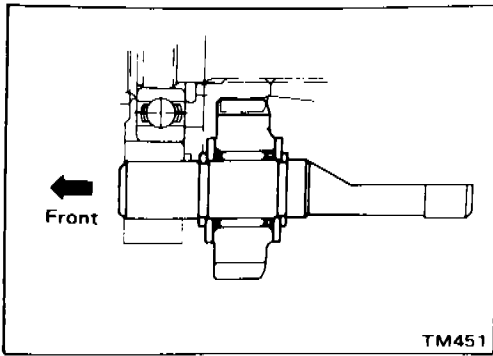

7. Install rear side components on mainshaft and counter gear.
- a. Install reverse idler gear to reverse idler shaft with spacers, snap rings and needle bearing.

- b. Install insert retainer and O.D. synchronizer to mainshaft.
- Pay attention to direction of hub.

- c. Install O.D. gear bushing with Tool.
- d. Install O.D. main gear and needle bearing.
- e. Install spacer, reverse counter gear and O.D. counter gear.
- O.D. main gear and O.D. counter gear should be handled as a matched set.
- f. Install washer, roller bearing, steel roller and thrust washer.
- g. Tighten mainshaft lock nut temporarily.
- Always use new lock nut.

- h. Install countershaft rear end bearing with Tool.

8. Mesh 2nd and reverse gears, then tighten mainshaft lock nut with Tool.

ASSEMBLY

Case Components

1. Install front cover oil seal.
 - Apply multi-purpose grease to seal lip of oil seal before installing.

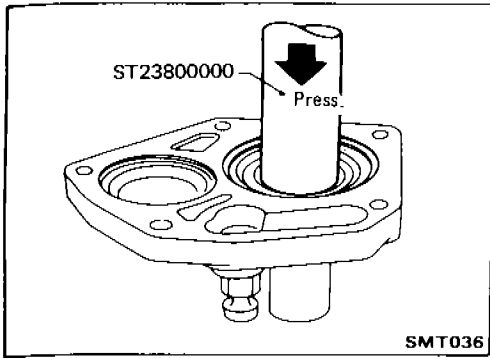

2. Apply sealant to mating surface of transmission case.

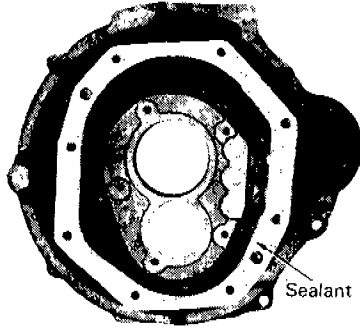

3. Install gear assembly onto transmission case.

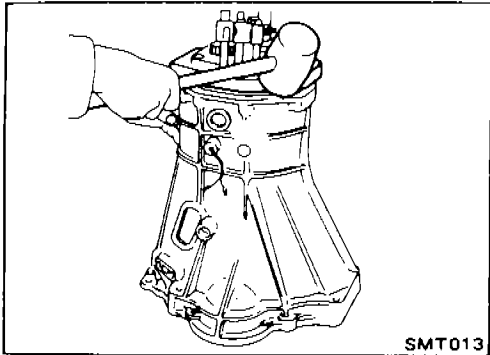

4. Install snap ring of main drive bearing.

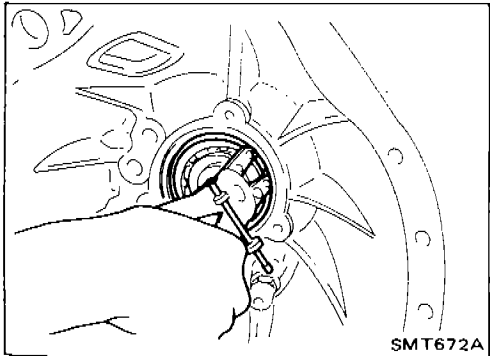

5. Apply sealant to mating surface of adapter plate.
6. Install rear extension.

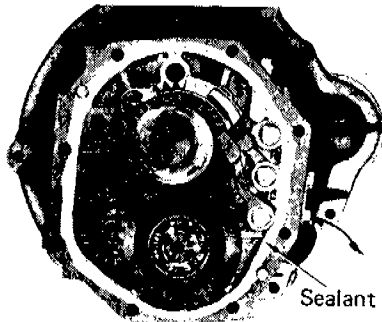

ASSEMBLY

Shift Control Components (Cont'd)

b. 3rd-4th shift fork

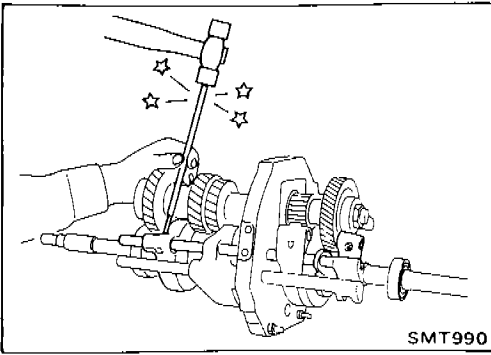

c. O.D.-reverse shift fork or reverse shift fork.

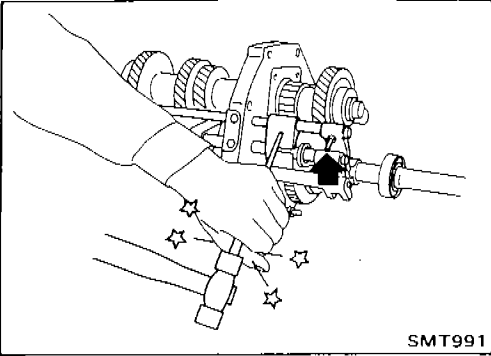

2. Install O.D. and reverse fork shaft by rotating O.D. and reverse bracket clockwise.

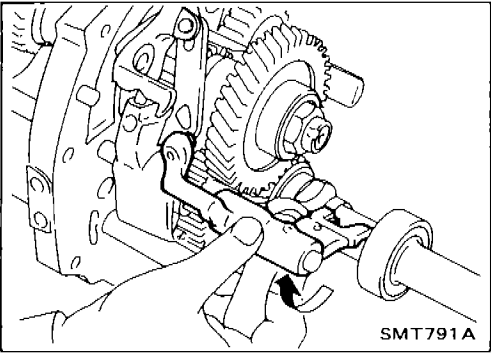

3. Install E-ring on O.D. and reverse fork rod.

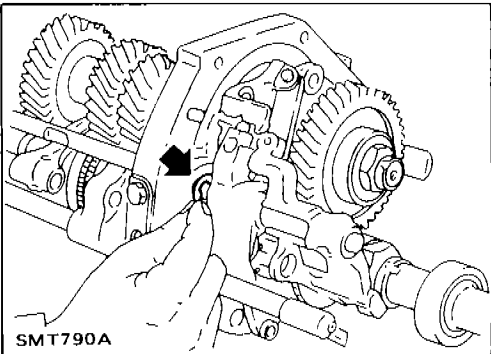

4. Install lever bracket securing bolt.

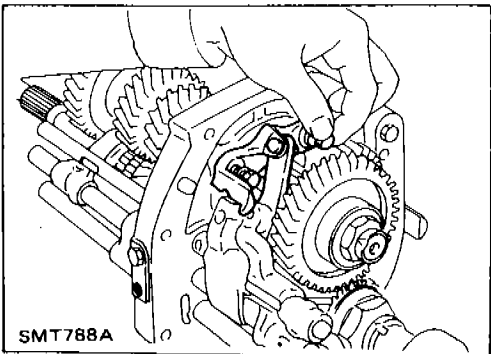

SERVICE DATA AND SPECIFICATIONS (S.D.S)

General Specifications

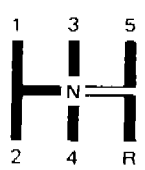
| Destination | Except Europe | Europe | |
|--------------------|-----------------------------------------------------------------------------------|--------------------------|------------------|
| Transmission model | FS5W71C | | |
| Number of speeds | 5 | | |
| Shift pattern |  | | |
| Synchromesh type | Warner | | |
| Gear ratio | | | |
| 1st | 3.321 | 3.592 | |
| 2nd | 1.902 | 2.057 | |
| 3rd | 1.308 | 1.361 | |
| 4th | 1.000 | 1.000 | |
| O.D. | 0.838 | 0.821 | |
| Reverse | 3.382 | 3.657 | |
| Number of teeth | | | |
| Mainshaft | | | |
| Drive | 22 | 21 | |
| 1st | 33 | 33 | |
| 2nd | 27 | 27 | |
| 3rd | 26 | 25 | |
| O.D. | 21 | 22 | |
| Reverse | 36 | 36 | |
| Countershaft | | | |
| Drive | 31 | 32 | |
| 1st | 14 | 14 | |
| 2nd | 20 | 20 | |
| 3rd | 28 | 28 | |
| O.D. | 37 | 39 | |
| Reverse | 15 | 15 | |
| Reverse idler gear | 21 | | |
| Oil capacity | ℓ (Imp pt) | 2.4 (4-1/4) | |
| Remarks | Sub-gear | ○ | |
| | Mainshaft braking mechanism | ○ | |
| | Double baulk ring type synchronizer | 2nd and 3rd synchronizer | 2nd synchronizer |

ASSEMBLY

Case Components (Cont'd)

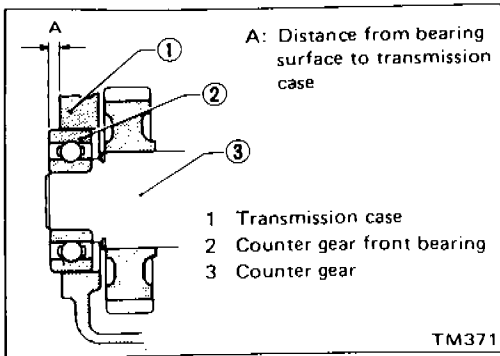

7. Select counter front bearing shim.
Counter front bearing shim: Refer to S.D.S.
8. Install gasket and front cover.

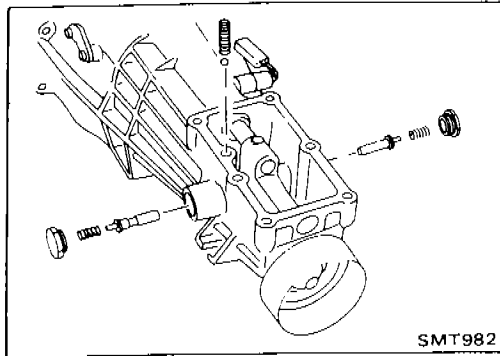

9. Install return spring plugs, check ball, return springs and select check plunger.
10. Install control housing and gasket.

SERVICE DATA AND SPECIFICATIONS (S.D.S)

Inspection and Adjustment (Cont'd)

Counter drive gear

Allowable clearance 0 - 0.18 mm (0 - 0.0071 in)

| Thickness mm (in) | Part number |
|-------------------|-------------|
| 1.4 (0.055) | 32215-E9000 |
| 1.5 (0.059) | 32215-E9001 |
| 1.6 (0.063) | 32215-E9002 |

AVAILABLE SHIMS

Counter front bearing

Unit: mm (in)

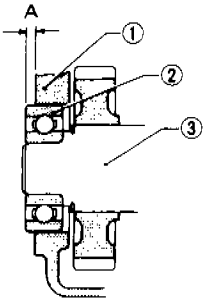

A: Distance from bearing surface to transmission case

- 1 Transmission case
- 2 Counter gear front bearing
- 3 Counter gear

TM371

| "A" | Thickness of shim | Part number |
|-------------------------------|-------------------|-------------|
| 4.52 - 4.71 (0.1780 - 0.1854) | Not necessary | |
| 4.42 - 4.51 (0.1740 - 0.1776) | 0.1 (0.004) | 32218-V5000 |
| 4.32 - 4.41 (0.1701 - 0.1736) | 0.2 (0.008) | 32218-V5001 |
| 4.22 - 4.31 (0.1661 - 0.1697) | 0.3 (0.012) | 32218-V5002 |
| 4.12 - 4.21 (0.1622 - 0.1657) | 0.4 (0.016) | 32218-V5003 |
| 4.02 - 4.11 (0.1583 - 0.1618) | 0.5 (0.020) | 32218-V5004 |
| 3.92 - 4.01 (0.1543 - 0.1579) | 0.6 (0.024) | 32218-V5005 |

SERVICE DATA AND SPECIFICATIONS (S.D.S)

Inspection and Adjustment

GEAR END PLAY

| Gear | End play mm (in) |
|-----------|-------------------------------|
| 1st gear | 0.31 - 0.41 (0.0122 - 0.0161) |
| 2nd gear | 0.11 - 0.21 (0.0043 - 0.0083) |
| 3rd gear | 0.11 - 0.21 (0.0043 - 0.0083) |
| O.D. gear | 0.24 - 0.41 (0.0094 - 0.0161) |

CLEARANCE BETWEEN BAULK RING AND GEAR For Europe

1st, 3rd, main drive and O.D. baulk ring

Unit: mm (in)

| | Standard | Wear limit |
|--------------------|------------------------------|-------------|
| 1st | 1.2 - 1.6 (0.047 - 0.063) | 0.8 (0.031) |
| 3rd and main drive | 1.2 - 1.6 (0.047 - 0.063) | |
| O.D. | 1.2 - 1.4 (0.047 - 0.055) | |

2nd baulk ring

Unit: mm (in)

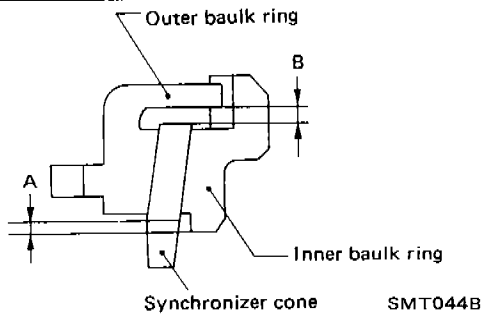

| Dimension | Standard | Wear limit |
|-----------|------------------------------|-------------|
| A | 0.6 - 1.1 (0.024 - 0.043) | 0.2 (0.008) |
| B | 0.7 - 0.9 (0.028 - 0.035) | |

Except for Europe

1st, main drive and O.D. baulk ring

Unit: mm (in)

| | Standard | Wear limit |
|------|------------------------------|-------------|
| 1st | 1.2 - 1.6 (0.047 - 0.063) | 0.8 (0.031) |
| O.D. | 1.2 - 1.4 (0.047 - 0.055) | |

2nd and 3rd baulk ring

Unit: mm (in)

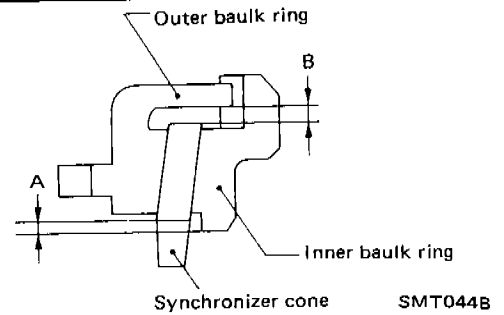

| Dimension | Standard | Wear limit |
|-----------|------------------------------|-------------|
| A | 0.6 - 1.1 (0.024 - 0.043) | 0.2 (0.008) |
| B | 0.7 - 0.9 (0.028 - 0.035) | |

AVAILABLE SNAP RINGS

Main drive gear bearing

Allowable clearance 0 - 0.13 mm (0 - 0.0051 in)

| Thickness mm (in) | Part number |
|-------------------|-------------|
| 1.73 (0.0681) | 32204-78005 |
| 1.80 (0.0709) | 32204-78000 |
| 1.87 (0.0736) | 32204-78001 |
| 1.94 (0.0764) | 32204-78002 |
| 2.01 (0.0791) | 32204-78003 |
| 2.08 (0.0819) | 32204-78004 |

Mainshaft front

Allowable clearance 0 - 0.18 mm (0 - 0.0071 in)

| Thickness mm (in) | Part number |
|-------------------|-------------|
| 2.4 (0.094) | 32263-V5200 |
| 2.5 (0.098) | 32263-V5201 |
| 2.6 (0.102) | 32263-V5202 |

Mainshaft rear end bearing

Allowable clearance 0 - 0.14 mm (0 - 0.0055 in)

| Thickness mm (in) | Part number |
|-------------------|-------------|
| 1.1 (0.043) | 32228-20100 |
| 1.2 (0.047) | 32228-20101 |
| 1.3 (0.051) | 32228-20102 |
| 1.4 (0.055) | 32228-20103 |

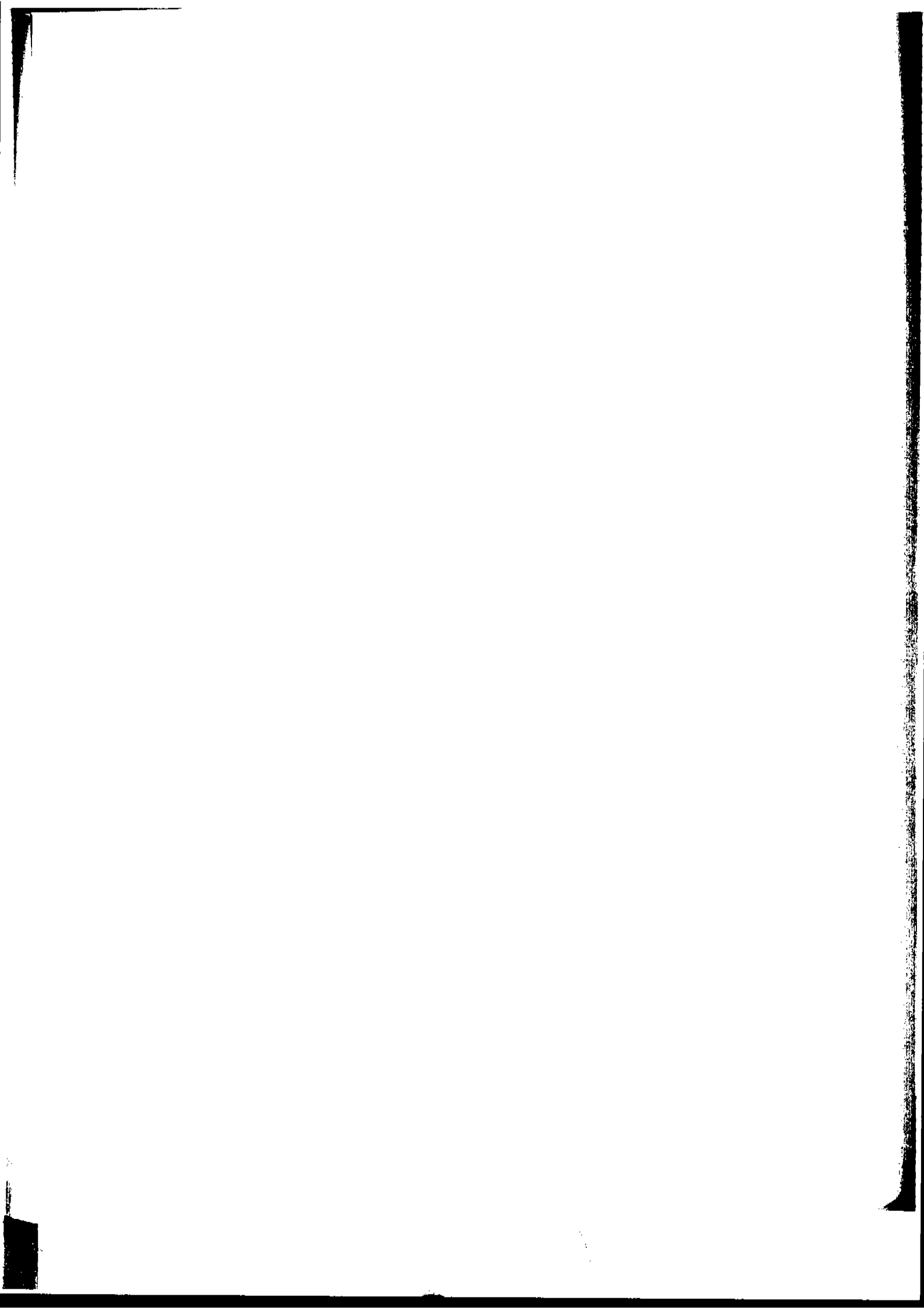

AUTOMATIC TRANSMISSION

SECTION **AT**

CONTENTS

| | |
|------------------------------------------------|--------|
| PREPARATION | AT- 2 |
| PRECAUTIONS | AT- 3 |
| A/T CONTROL DIAGRAM | AT- 4 |
| ON-VEHICLE SERVICE | AT- 7 |
| TROUBLE DIAGNOSES | AT- 11 |
| REMOVAL AND INSTALLATION | AT- 75 |
| MAJOR OVERHAUL | AT- 76 |
| DISASSEMBLY | AT- 80 |
| REPAIR FOR COMPONENT PARTS | AT- 91 |
| ASSEMBLY | AT-136 |
| SERVICE DATA AND SPECIFICATIONS (S.D.S.) | AT-156 |

AT

When you read wiring diagrams:

- Read GI section, "HOW TO READ WIRING DIAGRAMS".
- See EL section, "POWER SUPPLY ROUTING" for power distribution circuit.

When you perform trouble diagnoses, read GI section, "HOW TO FOLLOW FLOW CHART IN TROUBLE DIAGNOSES".

PREPARATION

SPECIAL SERVICE TOOLS

*: Special tool or commercial equivalent

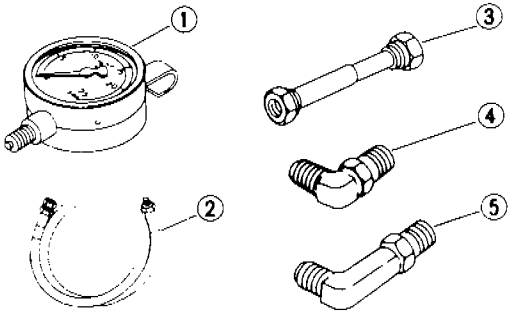
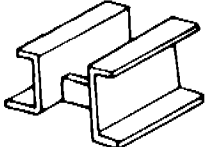
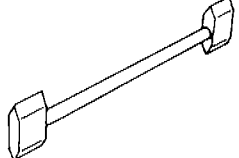
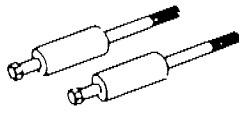
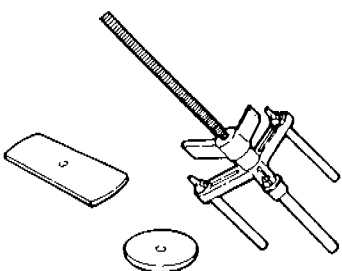
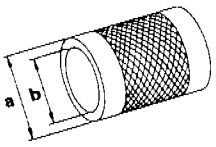
| Tool number Tool name | Description | |
|----------------------------------------------------------------------------------------------------------------------------------------------------------------------------------------------------------------------------------|---------------------------------------------------------------------------------------------------------------------------------------------------|---------------------------------------------------------------------|
| ST2505S001 Oil pressure gauge set ① ST25051001 Oil pressure gauge ② ST25052000 Hose ③ ST25053000 Joint pipe ④ ST25054000 Adapter ⑤ ST25055000 Adapter |  | Measuring line pressure |
| ST07870000 Transmission case stand |  | Disassembling and assembling A/T |
| KV31102100 Torque converter one- way clutch check tool |  | Checking one-way clutch in torque converter |
| ST25850000 Sliding hammer |  | Removing oil pump assembly |
| KV31102400 Clutch spring compressor |  | Removing and installing clutch return springs |
| ST33200000* Drift |  <p>a: 60 mm (2.36 in) dia. b: 44.5 mm (1.752 in) dia.</p> | Installing oil pump housing oil seal Installing rear oil seal |

PRECAUTIONS

Service Notice

- Before proceeding with disassembly, thoroughly clean the outside of the transmission. It is important to prevent the internal parts from becoming contaminated by dirt or other foreign matter.
- Disassembly should be done in a clean work area.
- Use lint-free cloth or towels for wiping parts clean. Common shop rags can leave fibers that could interfere with the operation of the transmission.
- When disassembling parts, place them in order in a parts rack so that they can be put back into the unit in their proper positions.
- All parts should be carefully cleaned with a general purpose, non-flammable solvent before inspection or reassembly.
- Gaskets, seals and O-rings should be replaced any time the transmission is disassembled.
- It is very important to perform functional tests whenever they are indicated.
- The valve body contains precision parts and requires extreme care when parts are removed and serviced. Place removed parts in order on a parts rack so they can be put back in the valve body in the same positions and sequences. Care will also prevent springs and small parts from becoming scattered or lost.
- Properly installed valves, sleeves, plugs, etc. will slide along their bores in the valve body under their own weight.
- Before assembly, apply a coat of recommended A.T.F. to all parts. Petroleum jelly may be applied to O-rings and seals and used to hold small bearings and washers in place during re-assembly. Do not use grease.
- Extreme care should be taken to avoid damage to O-rings, seals and gaskets when assembling.
- After overhaul, refill the transmission with new A.T.F.

A/T CONTROL DIAGRAM

Hydraulic Control Circuits

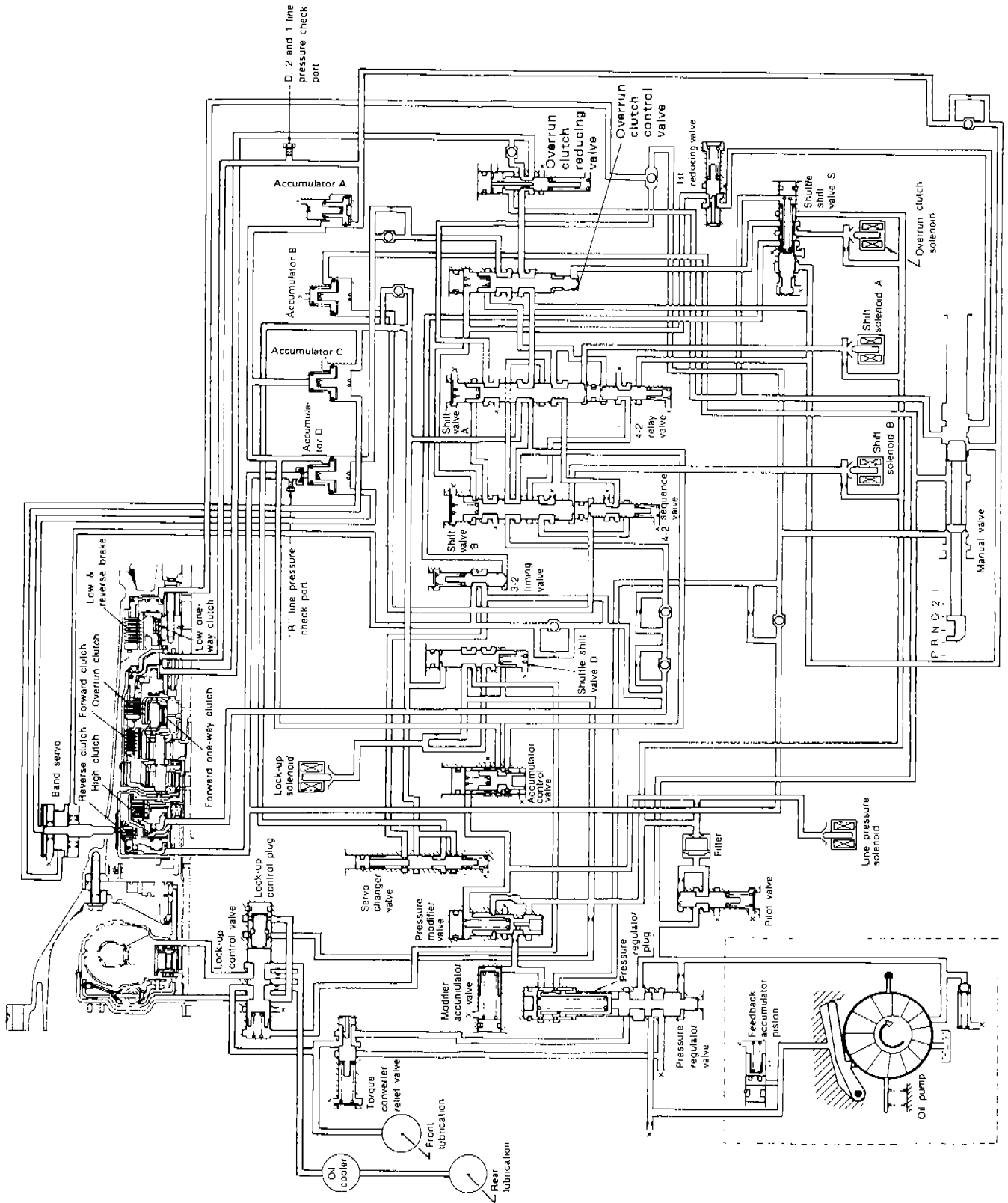

SAT123B

AT-4

A/T CONTROL DIAGRAM

Electrical Control Chart

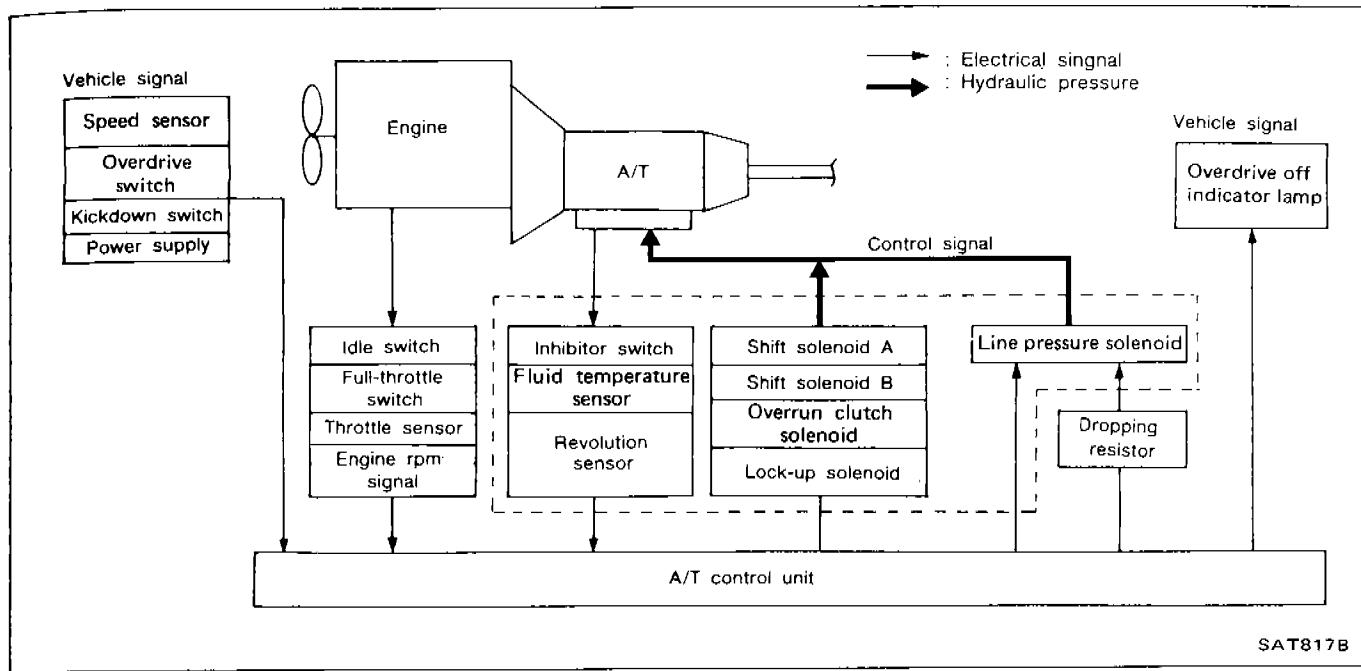

Mechanical Operation

| Shift position | Reverse clutch | High clutch | Forward clutch | Overrun clutch | Band servo | | | Forward one-way clutch | Low one-way clutch | Low & reverse brake | Lock-up | Remarks |
|----------------|----------------|-------------|----------------|----------------|------------|-------------|-----------|------------------------|--------------------|---------------------|---------|-----------------------------------------------|
| | | | | | 2nd apply | 3rd release | 4th apply | | | | | |
| P | | | | | | | | | | | | PARK |
| R | ○ | | | | | | | | | ○ | | REVERSE |
| N | | | | | | | | | | | | NEUTRAL |
| D *4 | 1st | | ○ | ⊗ | | | | ● | ● | | | Automatic shift 1 → 2 → 3 → 4 |
| | 2nd | | ○ | *1 ○ | ○ | | | ● | | | | |
| | 3rd | | ○ | ○ | ⊗ | *2 ⊗ | ⊗ | ● | | | | |
| | 4th | | ○ | ⊗ | | *3 ⊗ | ⊗ | ○ | | | ○ | |
| 2 | 1st | | ○ | ⊗ | | | | ● | ● | | | Automatic shift 1 → 2 |
| | 2nd | | ○ | ○ | ○ | | | ● | | | | |
| 1 | 1st | | ○ | ○ | | | | ● | | ○ | | Locks (held stationary) in 1st speed 1 → 2 |
| | 2nd | | ○ | ○ | ○ | | | ● | | | | |

*1. Operates when overdrive switch is set in "OFF" position.

*2. Oil pressure is applied to both 2nd "apply" side and 3rd "release" side of band servo piston. However, because oil pressure area on the "release" side is greater than that on the "apply" side, brake band does not contract.

*3. Oil pressure is applied to 4th "apply" side in condition *2 above, and brake band contracts.

*4. A/T will not shift to 4th when overdrive switch is set in "OFF" position.

○ : Operates.

○ : Operates when throttle opening is less than 1/16. Engine brake activates.

● : Operates during "progressive" acceleration.

⊗ : Operates but does not affect power transmission.

⊗ : Operates when throttle opening is less than 1/16 but does not affect engine brake.

A/T CONTROL DIAGRAM

Cross-Sectional View

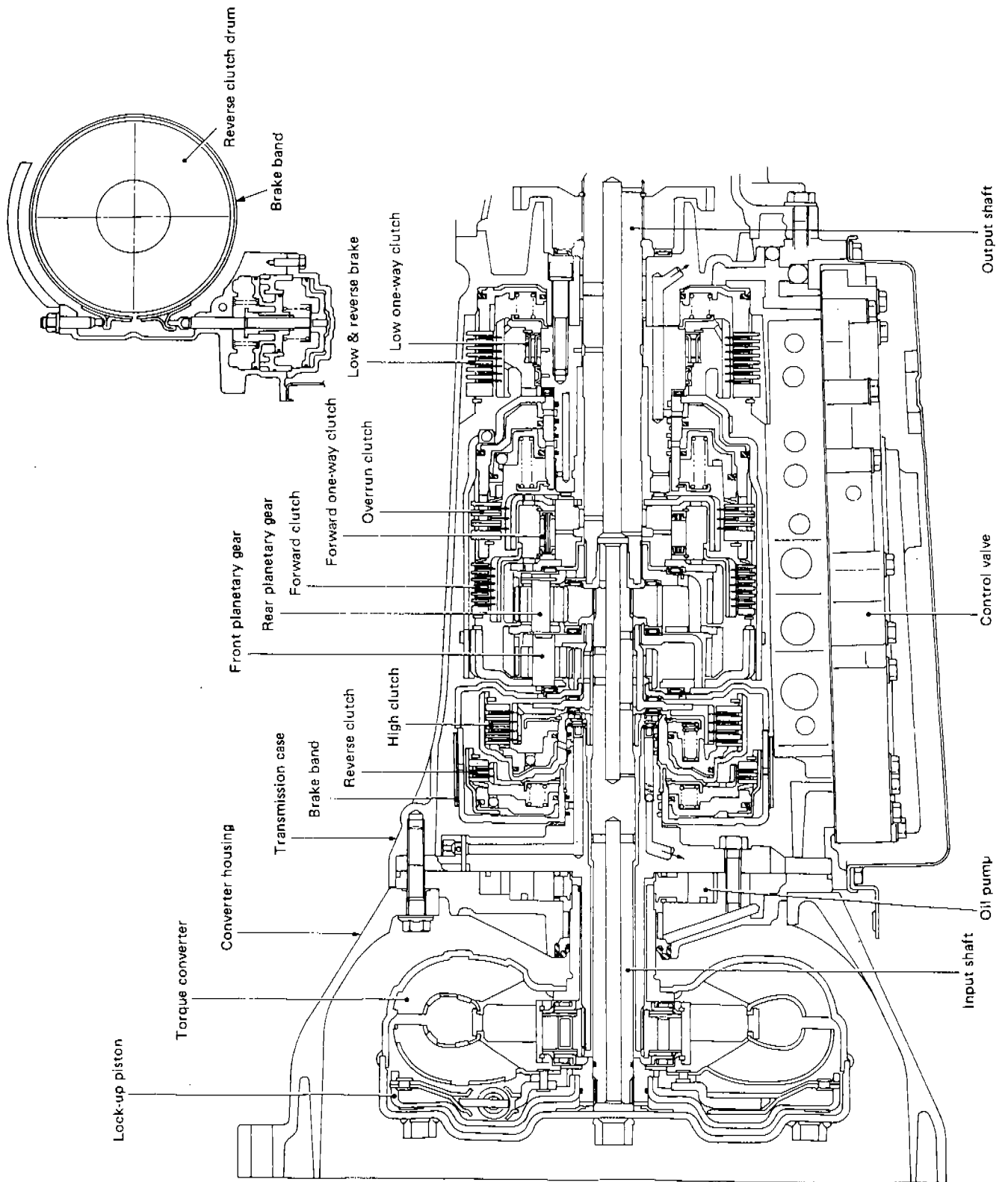

AT-6

SAT125B

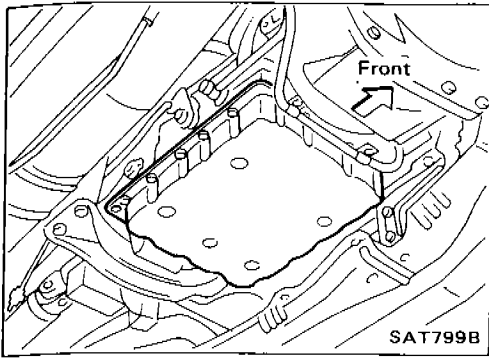

Control Valve Assembly and Accumulators Inspection

1. Remove oil pan and gasket and drain A.T.F.

2. Remove oil strainer.

3. Remove control valve assembly by removing fixing bolts and disconnecting harness connector.

Bolt length and location

| Bolt symbol | ℓ mm (in) |  ℓ |
|-------------|-----------|-----------------------------------------------------------------------------------------|
| Ⓐ | 33 (1.30) | |
| Ⓑ | 45 (1.77) | |

4. Remove solenoids and valves from valve body if necessary.
5. Remove terminal cord assembly if necessary.

6. Remove accumulator A, B, C and D by applying compressed air if necessary.

- Hold each piston with rag.
- 7. Reinstall any part removed.
- Always use new sealing parts.

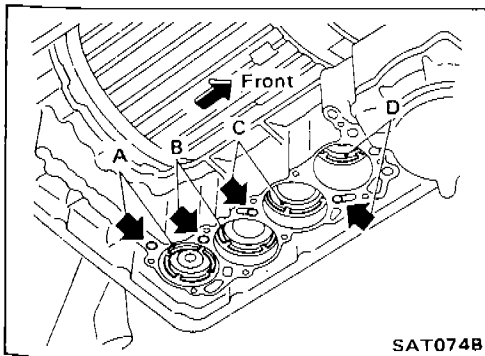
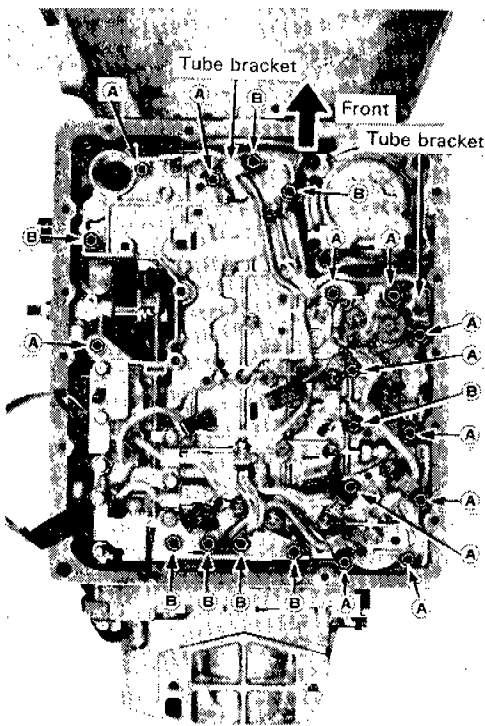

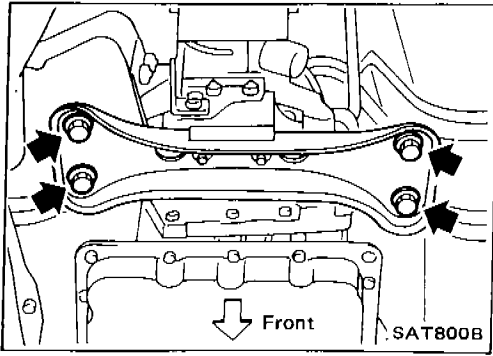

Revolution Sensor Replacement

1. Remove rear engine mounting member from body panel while supporting A/T with jack.
2. Lower A/T assembly as much as possible.

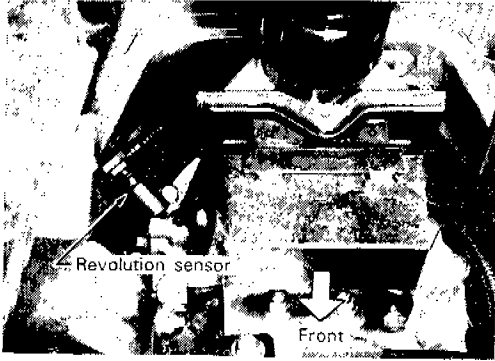

3. Remove revolution sensor from A/T assembly.
 4. Reinstall any part removed.
- **Always use new sealing parts.**

Rear Oil Seal Replacement

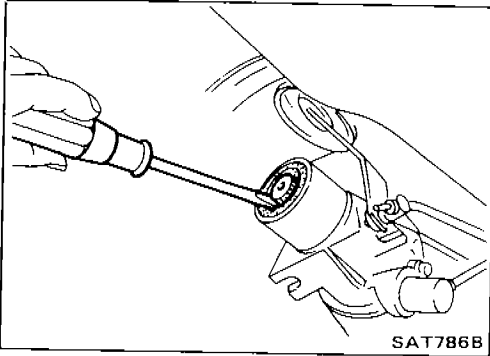

1. Remove propeller shaft from vehicle. — Refer to section PD.
2. Remove rear oil seal.

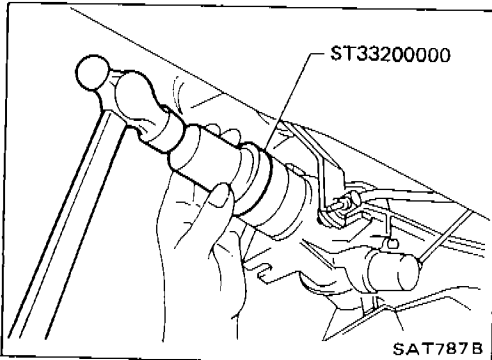

3. Install rear oil seal.
- **Apply A.T.F. before installing.**
4. Reinstall any part removed.

Parking Components Inspection

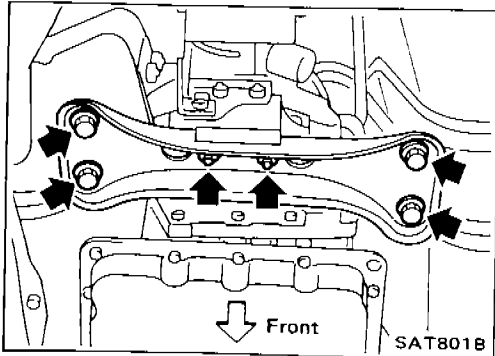

1. Remove propeller shaft from vehicle. — Refer to section PD.
2. Remove rear engine mounting member from A/T assembly.

Parking Components Inspection (Cont'd)

3. Remove rear extension from transmission case.
 4. Replace parking components if necessary.
 5. Reinstall any part removed.
- Always use new sealing parts.

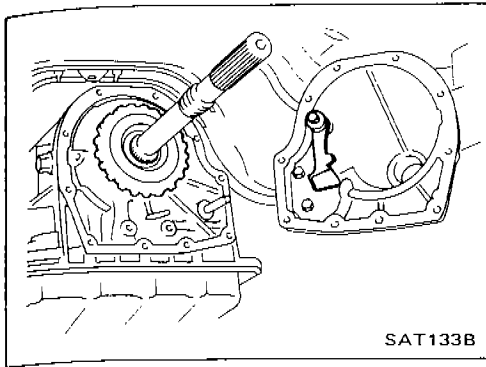

Inhibitor Switch Adjustment

1. Remove manual control linkage from manual shaft of A/T assembly.
2. Set manual shaft of A/T assembly in "N" position.
3. Loosen inhibitor switch fixing bolts.

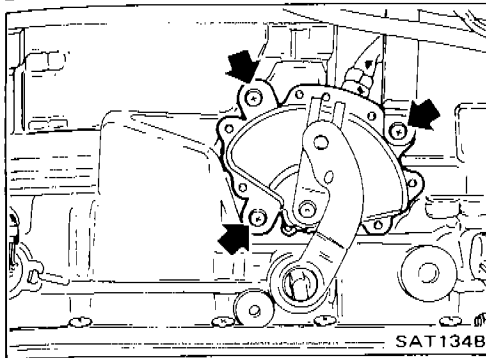

4. Insert pin into adjustment holes in both inhibitor switch and manual shaft of A/T assembly as near vertical as possible.
5. Reinstall any part removed.
6. Check continuity of inhibitor switch. — Refer to "Electrical Components Inspection".

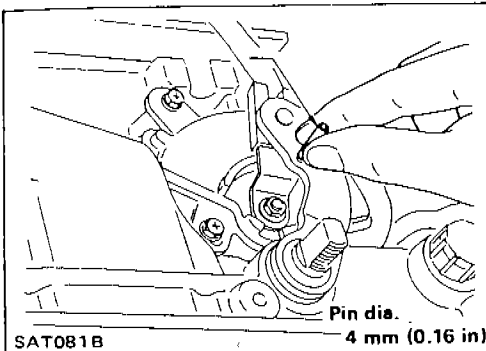

Manual Control Linkage Adjustment

Move selector lever from "P" range to "1" range. You should be able to feel the detents in each range. If the detents cannot be felt or the pointer indicating the range is improperly aligned, the linkage needs adjustment.

1. Place selector lever in "P" range.
2. Loosen lock nuts.

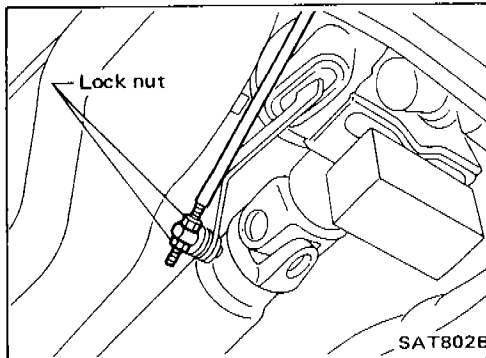

3. Tighten lock nut (X) until it touches trunnion pulling selector lever toward "R" range side without pushing button.
4. Back off lock nut (X) 1 turn and tighten lock nut (Y) to the specified torque.

Lock nut:

(Y): 11 - 15 N·m (1.1 - 1.5 kg-m, 8 - 11 ft-lb)

5. Move selector lever from "P" range to "1" range. Make sure that selector lever can move smoothly.

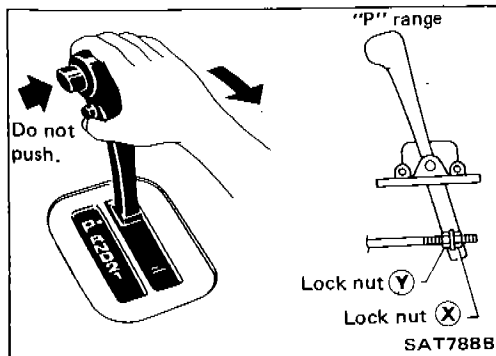

ON-VEHICLE SERVICE

NOTE

AT-10

TROUBLE DIAGNOSES

Contents

| | |
|---------------------------------------------------------------------------------------------------------------------------------------------------------------------------------------------------------------------------------------------------------------|-------|
| How to Perform Trouble Diagnoses for Quick and Accurate Repair | AT-13 |
| Preliminary Check | AT-14 |
| A/T Electrical Parts Location | AT-25 |
| Circuit Diagram for Quick Pinpoint Check | AT-27 |
| Wiring Diagram | AT-28 |
| Self-diagnosis | AT-30 |
| SELF-DIAGNOSTIC PROCEDURE | AT-30 |
| JUDGEMENT OF SELF-DIAGNOSIS CODE | AT-32 |
| REVOLUTION SENSOR CIRCUIT CHECK | AT-36 |
| SPEED SENSOR CIRCUIT CHECK | AT-36 |
| THROTTLE SENSOR CIRCUIT CHECK | AT-37 |
| SHIFT SOLENOID A CIRCUIT CHECK | AT-38 |
| SHIFT SOLENOID B CIRCUIT CHECK | AT-39 |
| OVERRUN CLUTCH CIRCUIT CHECK | AT-40 |
| LOCK-UP SOLENOID CIRCUIT CHECK | AT-41 |
| FLUID TEMPERATURE SENSOR CIRCUIT AND A/T CONTROL UNIT POWER SOURCE CIRCUIT CHECKS | AT-42 |
| ENGINE REVOLUTION SIGNAL CIRCUIT CHECK | AT-43 |
| LINE PRESSURE SOLENOID CIRCUIT CHECK | AT-44 |
| INHIBITOR, OVERDRIVE, KICKDOWN AND IDLE SWITCH CIRCUIT CHECKS | AT-45 |
| Diagnostic Procedure 1 (SYMPTOM: O.D. OFF indicator lamp does not come on for about 2 seconds when turning ignition switch to "ON".) | AT-47 |
| Diagnostic Procedure 2 (SYMPTOM: Engine cannot be started with selector lever in "P" or "N" range or engine can be started with selector lever in "D", "2", "1" or "R" range.) | AT-48 |
| Diagnostic Procedure 3 (SYMPTOM: Vehicle moves when it is pushed forward or backward with selector lever in "P" range.) | AT-48 |
| Diagnostic Procedure 4 (SYMPTOM: Vehicle moves forward when setting "N" range.) | AT-49 |
| Diagnostic Procedure 5 (SYMPTOM: There is large shock when changing from "N" to "R" range.) | AT-50 |
| Diagnostic Procedure 6 (SYMPTOM: vehicle does not creep backward when selecting "R" range.) | AT-51 |
| Diagnostic Procedure 7 (SYMPTOM: Vehicle does not creep forward when selecting "D", "2" and "1" range.) | AT-52 |
| Diagnostic Procedure 8 (SYMPTOM: Vehicle cannot be started from D ₁ on Cruise test—Part 1.) | AT-53 |
| Diagnostic Procedure 9 (SYMPTOM: A/T does not shift from D ₁ to D ₂ at specified speed. A/T does not shift from D ₄ to D ₂ when depressing accelerator pedal fully at the specified speed.) | AT-54 |
| Diagnostic Procedure 10 (SYMPTOM: A/T does not shift from D ₂ to D ₃ at the specified speed.) | AT-55 |
| Diagnostic Procedure 11 (SYMPTOM: A/T does not shift from D ₃ to D ₄ at the specified speed.) | AT-56 |
| Diagnostic Procedure 12 (SYMPTOM: A/T does not perform lock-up at the specified speed.) | AT-57 |
| Diagnostic Procedure 13 (SYMPTOM: A/T does not hold lock-up condition for more than 30 seconds.) | AT-58 |
| Diagnostic Procedure 14 (SYMPTOM: Lock-up is not released when accelerator pedal is released.) | AT-58 |

TROUBLE DIAGNOSES

Contents (Cont'd)

| | |
|-----------------------------------------------------------------------------------------------------------------------------------------------------------------------------------------------------------------------------------------------------------------------------------------------------------------------------------------------------------------------------------------------------------------------------------------------------------------|-------|
| Diagnostic Procedure 15 (SYMPTOM: Engine speed does not return to idle smoothly when A/T is shifted from D ₄ to D ₃ with accelerator pedal released. Vehicle does not decelerate by engine brake when changing overdrive switch to "OFF" position with accelerator pedal released. Vehicle does not decelerate by engine brake when changing selector lever from "D" to "2" range with accelerator pedal released.) | AT-59 |
| Diagnostic Procedure 16 (SYMPTOM: Vehicle does not start from D ₁ on Cruise test — Part 2.) | AT-60 |
| Diagnostic Procedure 17 (SYMPTOM: Vehicle does not shift from D ₄ on D ₃ when changing overdrive switch to "OFF" position.) | AT-60 |
| Diagnostic Procedure 18 (SYMPTOM: A/T does not shift from D ₃ on D ₂ when changing selector lever from "D" to "2" range.) | AT-61 |
| Diagnostic Procedure 19 (SYMPTOM: Vehicle does not shift from 2 ₂ on 1 ₁ when changing selector lever from "2" to "1" range.) | AT-61 |
| Diagnostic Procedure 20 (SYMPTOM: Vehicle does not decelerate by engine brake when shifting from 2 ₂ (1 ₂) to 1 ₁ .) | AT-61 |
| Electrical Components Inspection | AT-62 |
| Final Check | AT-68 |
| Symptom Chart | AT-72 |

TROUBLE DIAGNOSES

How to Perform Trouble Diagnoses for Quick and Accurate Repair

WORK FLOW

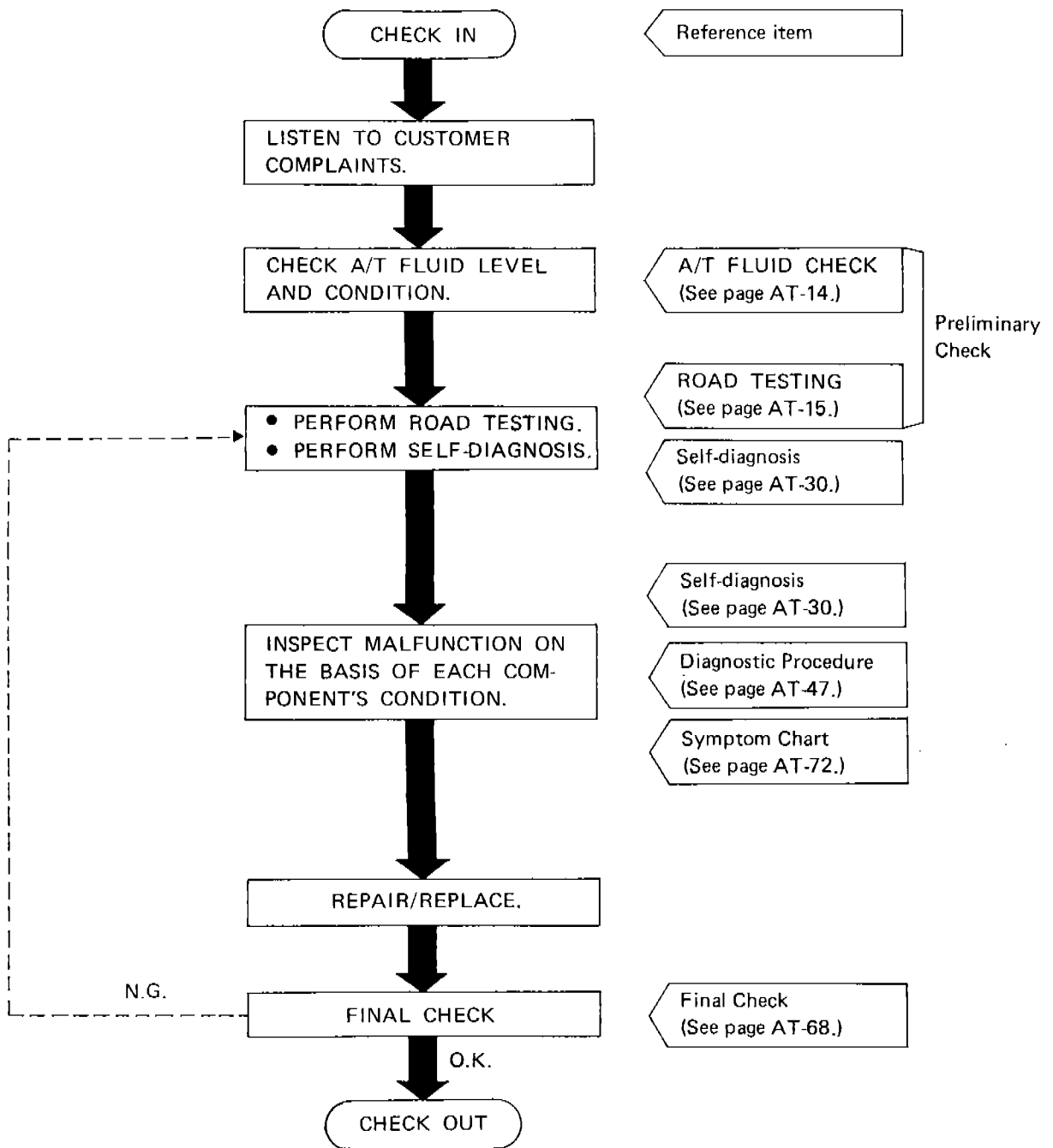

TROUBLE DIAGNOSES

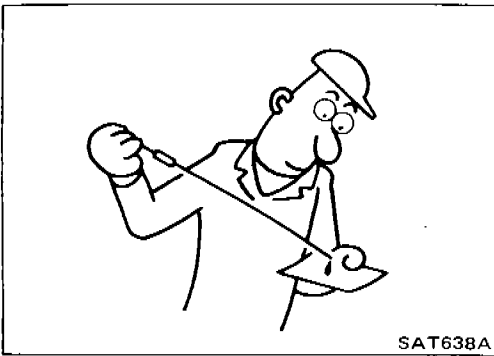
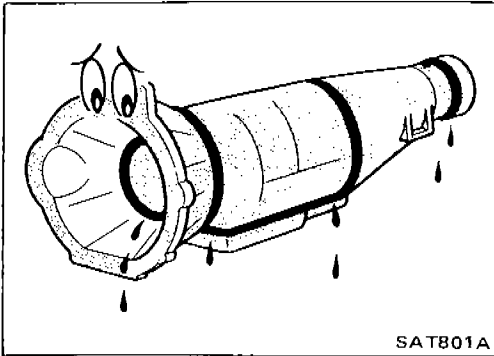
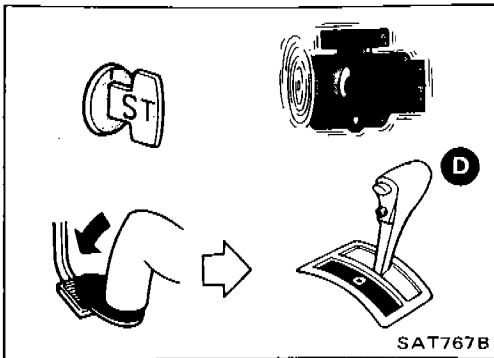

Preliminary Check

A/T FLUID CHECK

Fluid leakage check

1. Clean area suspected of leaking, — for example, mating surface of converter housing and transmission case.
2. Start engine, apply foot brake, place selector lever in "D" range and wait a few minutes.
3. Stop engine.

4. Check for fresh leakage.

Fluid condition check

| Fluid color | Suspected problem |
|------------------------------------------------|------------------------------------------------------------------------------|
| Dark or black with burned odor | Wear of frictional material |
| Milky pink | Water contamination — Road water entering through filler tube or breather |
| Varnished fluid, light to dark brown and tacky | Oxidation — Over or under filling — Overheating |

Fluid level check

Refer to section MA.

TROUBLE DIAGNOSES

ROAD TEST PROCEDURE

1. Check before engine is started



2. Check at idle



3. Cruise test

SAT786A

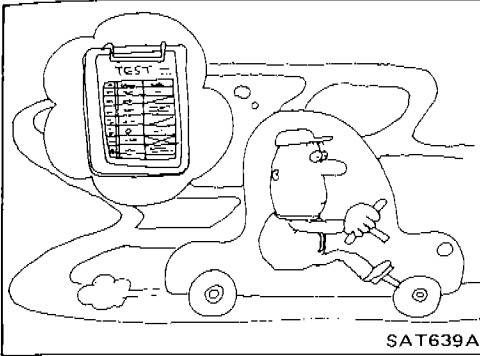

SAT639A

Preliminary Check (Cont'd)

ROAD TESTING

Description

- The purpose of this road test is to determine overall performance of automatic transmission and analyze causes of problems.
- The road test consists of the following three parts:
 1. Check before engine is started
 2. Check at idle
 3. Cruise test
- Before road test, familiarize yourself with all test procedures and items to check.
- Conduct tests on all items. Troubleshoot items which check out No Good after road test. Refer to "Self-diagnosis" and "Diagnostic Procedure".

TROUBLE DIAGNOSES

Preliminary Check (Cont'd)

1. Check before engine is started

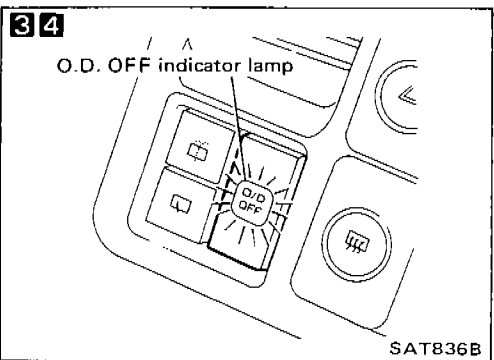
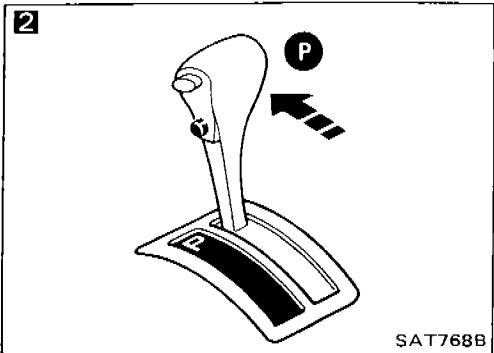
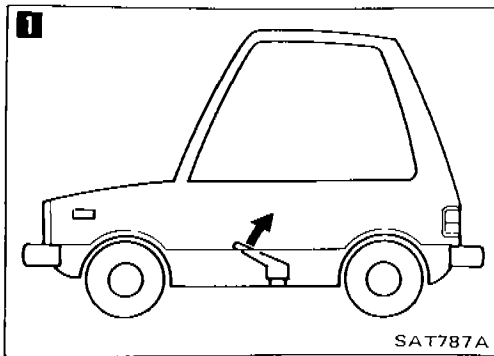

1
Park vehicle on flat surface.

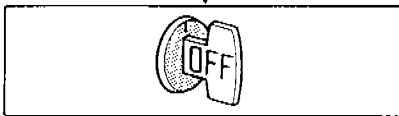

2
Move selector lever to "P" range.

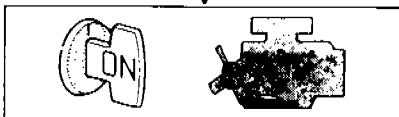

3
Does O.D. OFF indicator lamp come on for about 2 seconds?

No → Go to Diagnostic Procedure 1.

Yes
4
Does O.D. OFF indicator lamp flicker for about 8 seconds?

Yes → Perform self-diagnosis.
— Refer to SELF-DIAGNOSIS PROCEDURE.

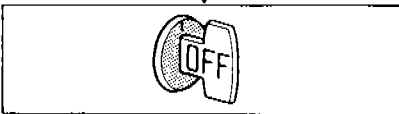

Perform self-diagnosis.
— Refer to SELF-DIAGNOSIS PROCEDURE and note N.G. items.

Go to "ROAD TESTING
— 2. Check at idle".

TROUBLE DIAGNOSES

Preliminary Check (Cont'd)

2. Check at idle

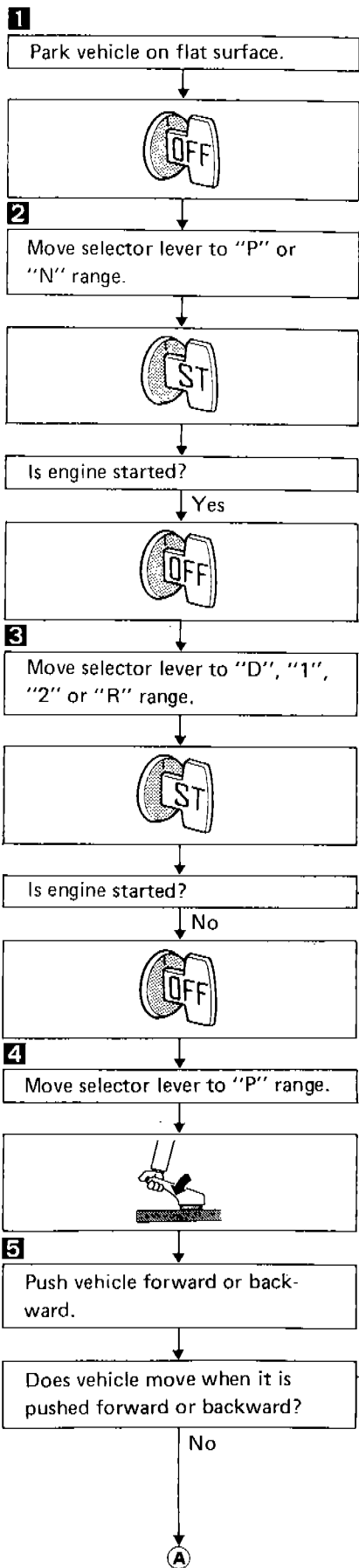
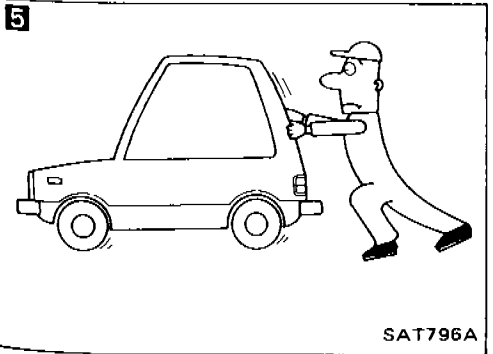
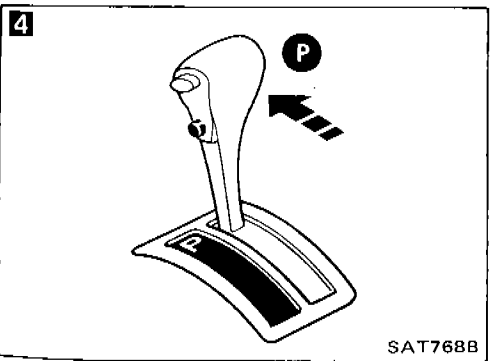
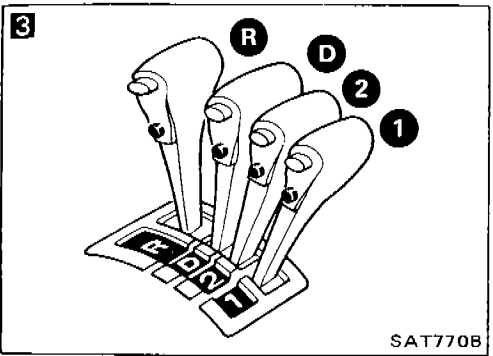
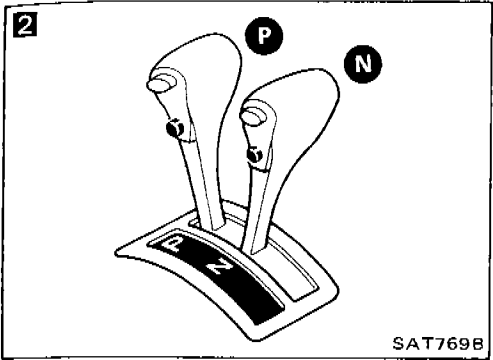
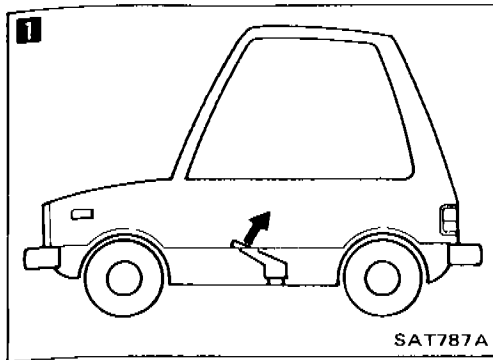

TROUBLE DIAGNOSES

Preliminary Check (Cont'd)

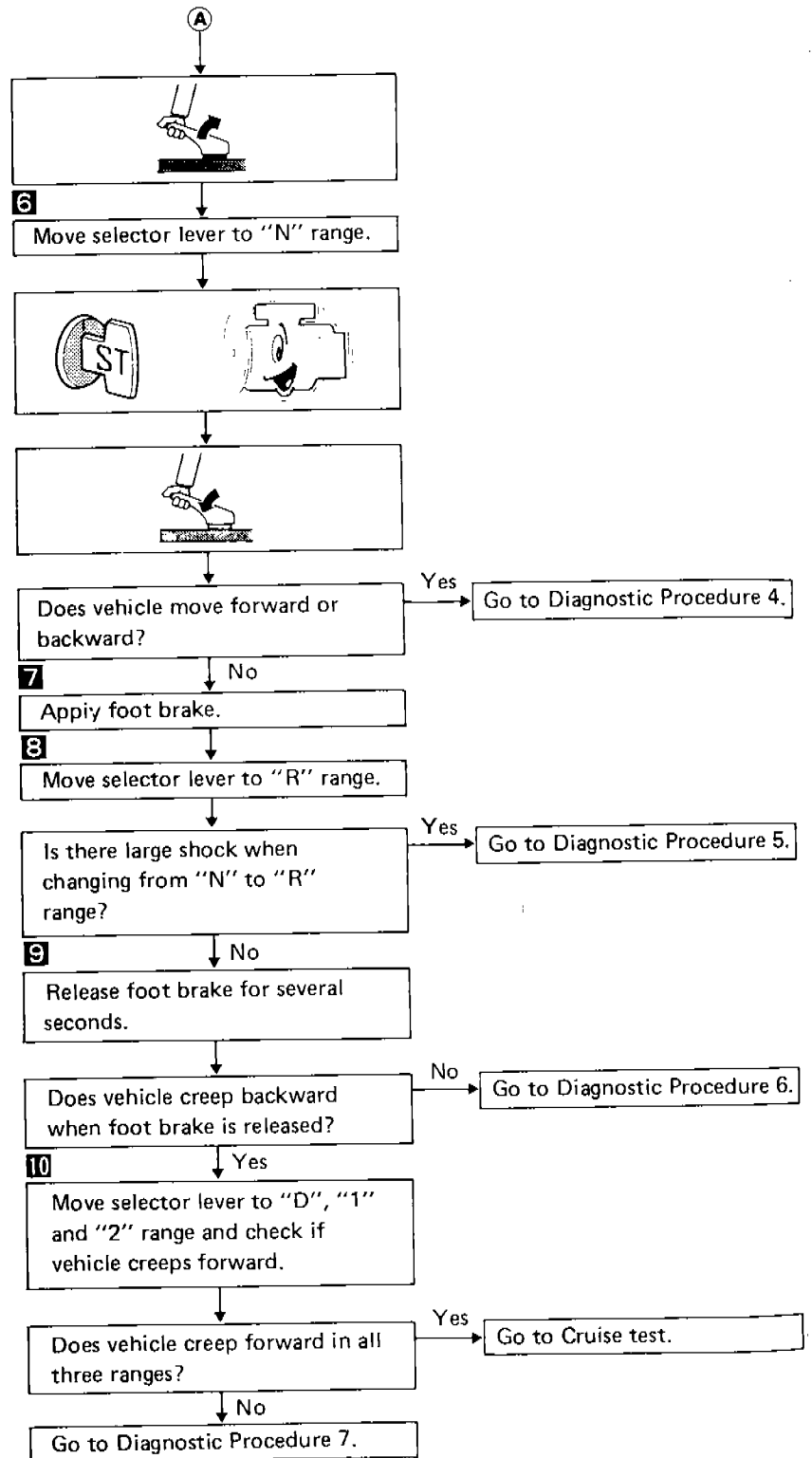
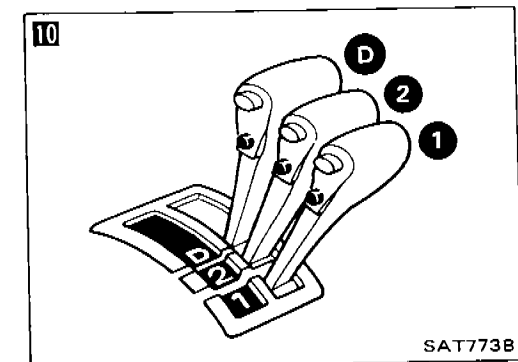
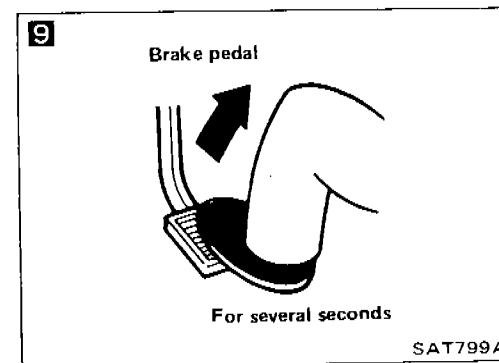
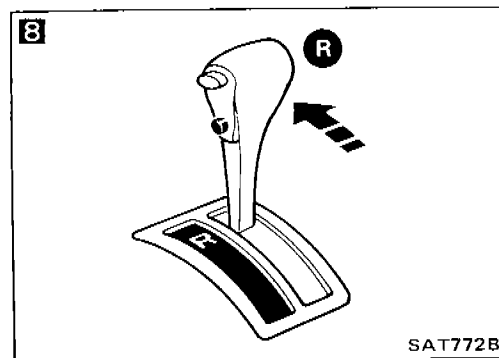
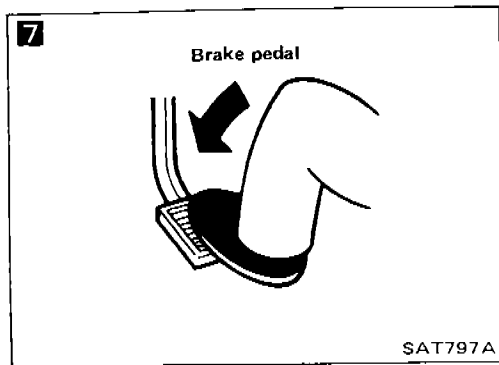
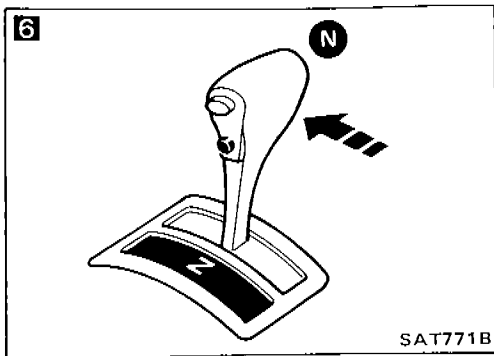

TROUBLE DIAGNOSES

Preliminary Check (Cont'd)

3. Cruise test

- Check all items listed in Parts 1 through 3.
- Throttle position can be controlled by voltage across terminals ⑪ and ⑮ of A/T control unit.

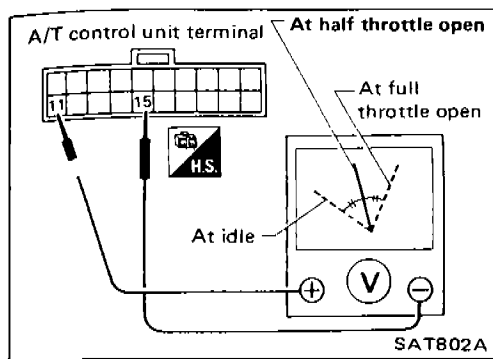

Cruise test – Part 1

1

Warm up engine until engine oil and A.T.F. reach operating temperature after vehicle has been driven approx. 10 minutes.

A.T.F. operating temperature:
50 - 80°C (122 - 176°F)

Park vehicle on flat surface.

2

Set overdrive switch in "ON" position.

3

Move selector lever to "P" range.

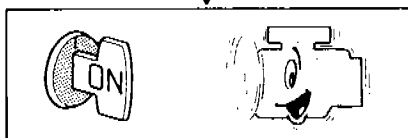

4

Move selector lever to "D" range.

5

Accelerate vehicle by constantly depressing accelerator pedal half-way.

Does vehicle start from D₁?

No

Go to Diagnostic Procedure 8.

Yes

A

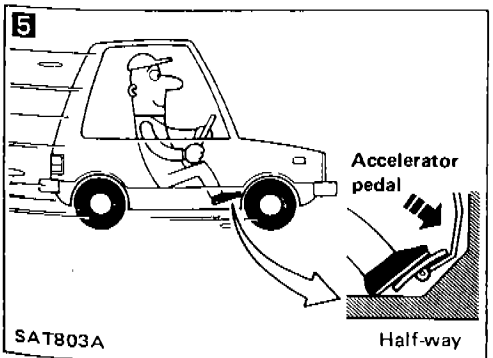
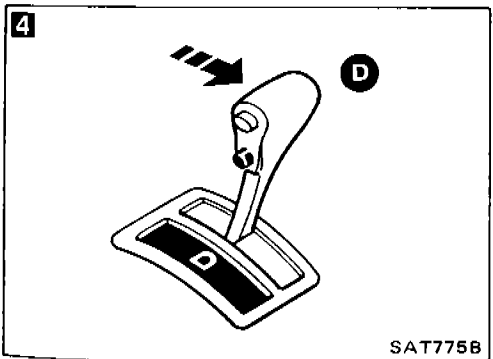
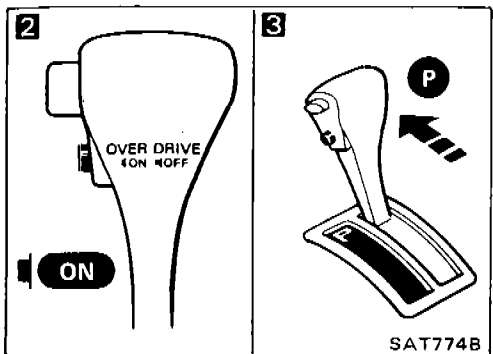
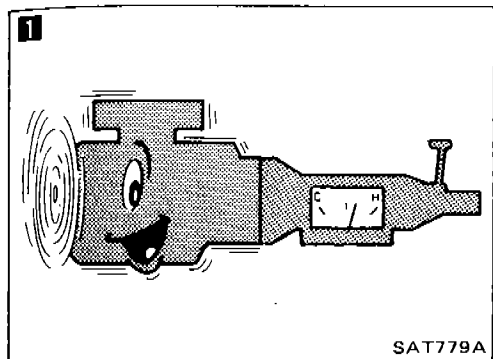

TROUBLE DIAGNOSES

Preliminary Check (Cont'd)

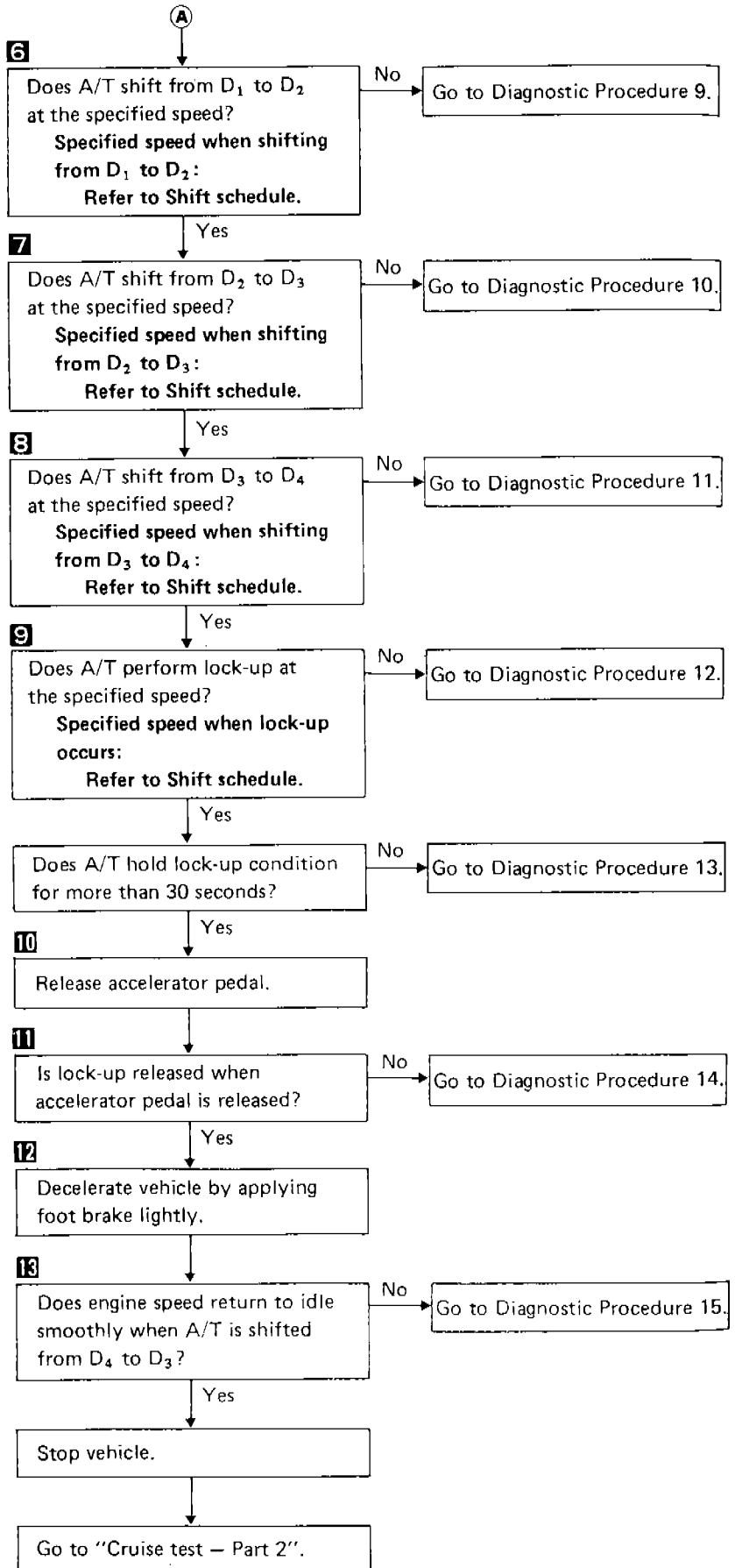
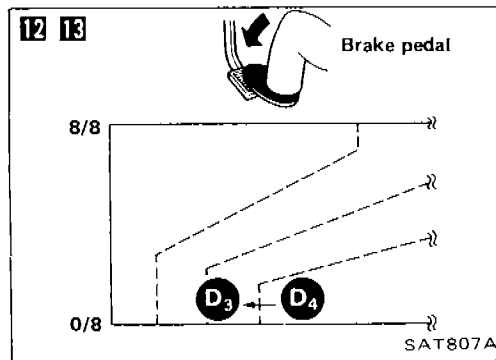
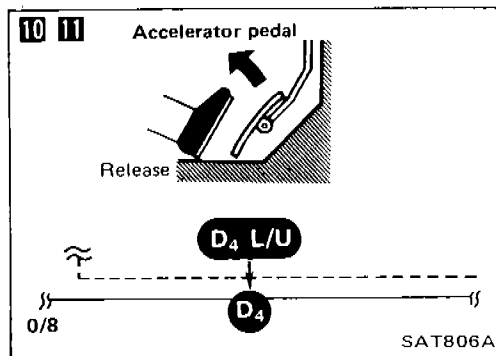
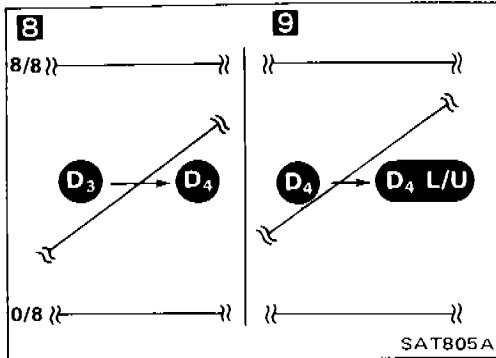
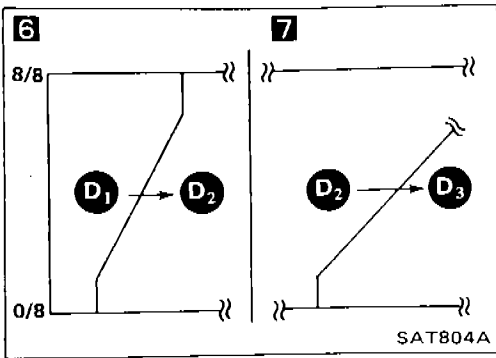

TROUBLE DIAGNOSES

Preliminary Check (Cont'd)

Cruise test – Part 2

Confirm overdrive switch is in "ON" position.

Confirm selector lever is in "D" range.

1 Accelerate vehicle by half throttle again.

Does vehicle start from D₁? No → Go to Diagnostic Procedure 16.

2 Accelerate vehicle to A km/h as shown in illustration.

3 Release accelerator pedal and then quickly depress it fully.

4 Does A/T shift from D₄ to D₂ as soon as accelerator pedal is depressed fully? No → Go to Diagnostic Procedure 9.

5 Does A/T shift from D₂ to D₃ at the specified speed?
Specified speed when shifting from D₂ to D₃:
Refer to Shift schedule. No → Go to Diagnostic Procedure 10.

6 Release accelerator pedal after shifting from D₂ to D₃.

7 Does A/T shift from D₃ to D₄ and does vehicle decelerate by engine brake? No → Go to Diagnostic Procedure 11.

Stop vehicle.

Go to "Cruise test – Part 3".

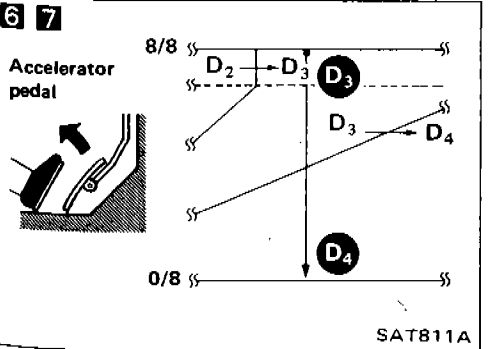
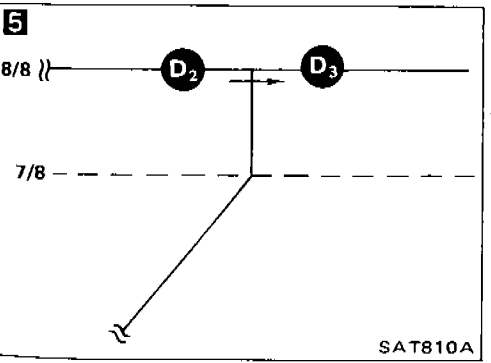
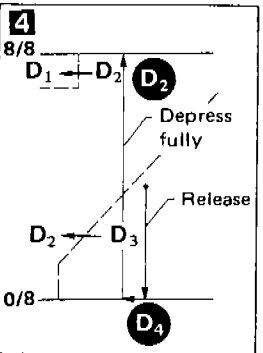
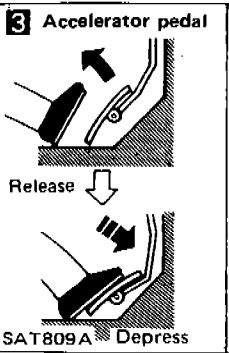
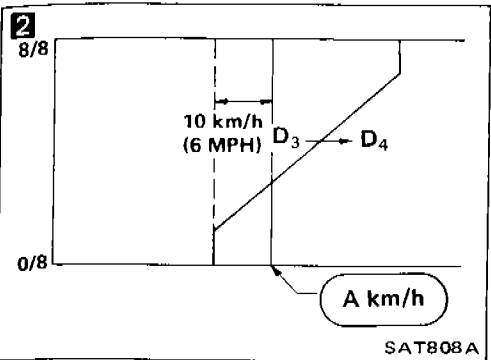
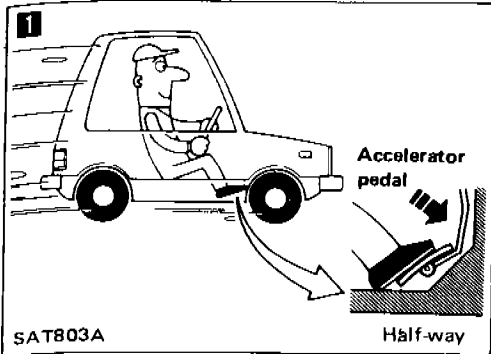

TROUBLE DIAGNOSES

Preliminary Check (Cont'd)

Cruise test – Part 3

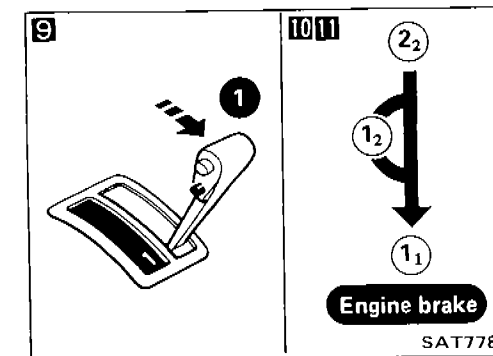
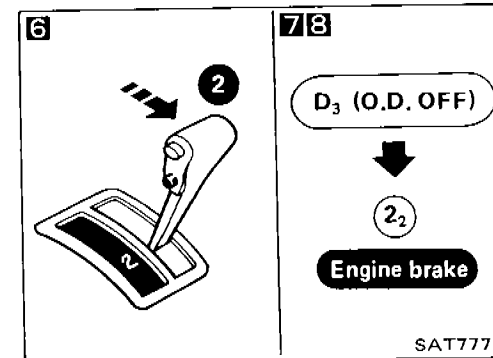
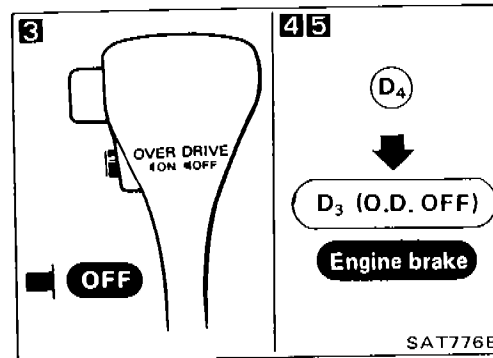
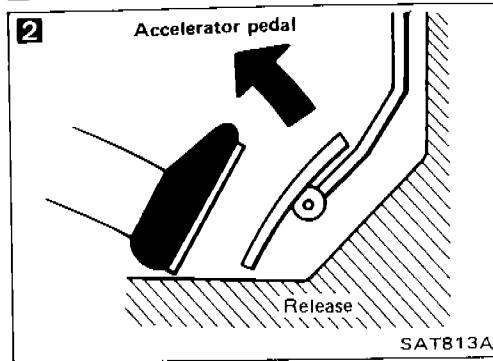
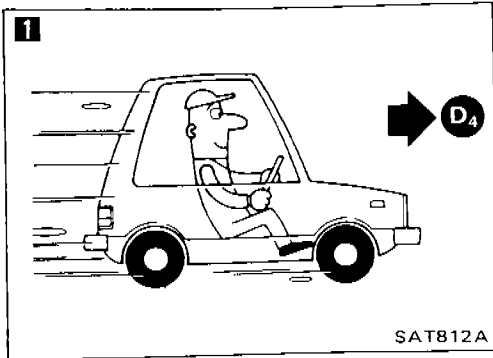

Confirm overdrive switch is in "ON" position.

Confirm selector lever is in "D" range.

1 Accelerator vehicle using half-throttle to D₄.

2 Release accelerator pedal.

3 Set overdrive switch in "OFF" position while driving in D₄ range.

4 Does A/T shift from D₄ to D₃? No → Go to Diagnostic Procedure 17.

5 Does vehicle decelerate by engine brake? No → Go to Diagnostic Procedure 15.

6 Move selector lever from "D" to "2" range while driving in D₃.

7 Does A/T shift from D₃ to 2₂? No → Go to Diagnostic Procedure 18.

8 Does vehicle decelerate by engine brake? No → Go to Diagnostic Procedure 15.

9 Move selector lever from "2" to "1" range while driving in 2₂.

10 Does A/T shift from 2₂ to 1₁ range? No → Go to Diagnostic Procedure 19.

11 Does vehicle decelerate by engine brake? No → Go to Diagnostic Procedure 20.

Stop vehicle.

Perform self-diagnosis. — Refer to SELF-DIAGNOSIS PROCEDURE.

TROUBLE DIAGNOSES

Preliminary Check (Cont'd)

Vehicle speed when shifting gears

Europe

| Throttle position | Vehicle speed km/h (MPH) | | | | | | |
|-------------------|---------------------------------|---------------------------------|---------------------------------|---------------------------------|---------------------------------|---------------------------------|---------------------------------|
| | D ₁ → D ₂ | D ₂ → D ₃ | D ₃ → D ₄ | D ₄ → D ₃ | D ₃ → D ₂ | D ₂ → D ₁ | 1 ₂ → 1 ₁ |
| Full throttle | 58 - 62 (36 - 39) | 109 - 115 (68 - 71) | 176 - 186 (109 - 116) | 170 - 180 (106 - 112) | 104 - 110 (65 - 68) | 44 - 48 (27 - 30) | 53 - 57 (33 - 35) |
| Half throttle | 41 - 45 (25 - 28) | 78 - 84 (48 - 52) | 125 - 135 (78 - 84) | 74 - 84 (46 - 52) | 29 - 35 (18 - 22) | 10 - 14 (6 - 9) | 53 - 57 (33 - 35) |

Except Europe

| Throttle position | Vehicle speed km/h (MPH) | | | | | | |
|-------------------|---------------------------------|---------------------------------|---------------------------------|---------------------------------|---------------------------------|---------------------------------|---------------------------------|
| | D ₁ → D ₂ | D ₂ → D ₃ | D ₃ → D ₄ | D ₄ → D ₃ | D ₃ → D ₂ | D ₂ → D ₁ | 1 ₂ → 1 ₁ |
| Full throttle | 54 - 58 (34 - 36) | 101 - 107 (63 - 66) | 164 - 174 (102 - 108) | 158 - 168 (98 - 104) | 95 - 101 (59 - 63) | 44 - 48 (27 - 30) | 53 - 57 (33 - 35) |
| Half throttle | 41 - 45 (25 - 28) | 73 - 79 (45 - 49) | 119 - 129 (74 - 80) | 78 - 88 (48 - 55) | 34 - 40 (21 - 25) | 10 - 14 (6 - 9) | 53 - 57 (33 - 35) |

Vehicle speed when performing and releasing lock-up

Europe

| Throttle position | D ₄ | |
|-------------------|--------------------------|--------------------------|
| | Vehicle speed km/h (MPH) | |
| | Lock-up "ON" | Lock-up "OFF" |
| Full throttle | 176 - 186 (109 - 116) | 170 - 180 (106 - 112) |
| Half throttle | 126 - 134 (78 - 83) | 110 - 118 (68 - 73) |

Except Europe

| Throttle position | D ₄ | |
|-------------------|--------------------------|-------------------------|
| | Vehicle speed km/h (MPH) | |
| | Lock-up "ON" | Lock-up "OFF" |
| Full throttle | 164 - 174 (102 - 108) | 158 - 168 (98 - 104) |
| Half throttle | 120 - 128 (75 - 80) | 102 - 110 (63 - 68) |

TROUBLE DIAGNOSES

Preliminary Check (Cont'd)

Shift schedule
Europe

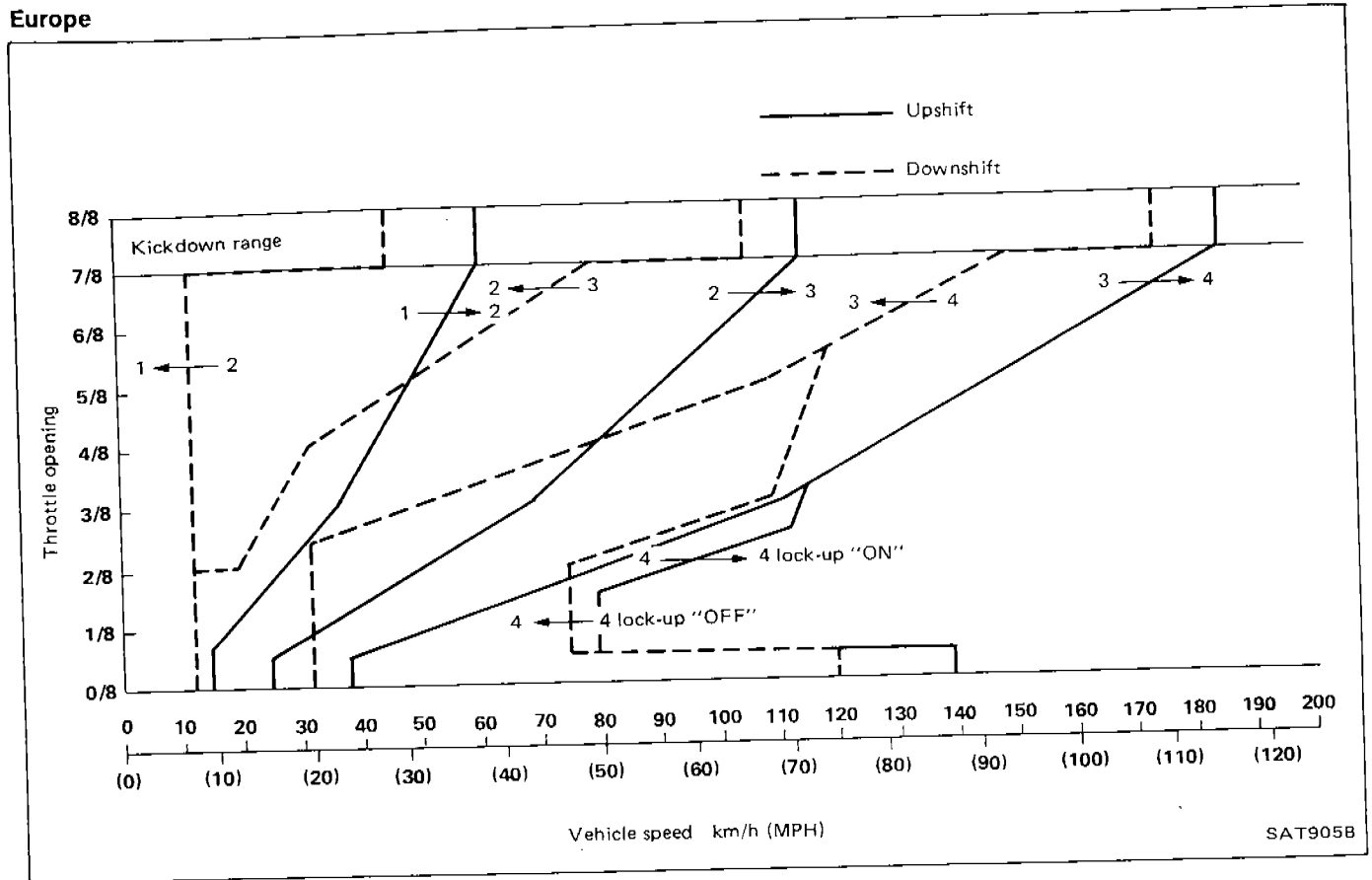

SAT905B

Except Europe

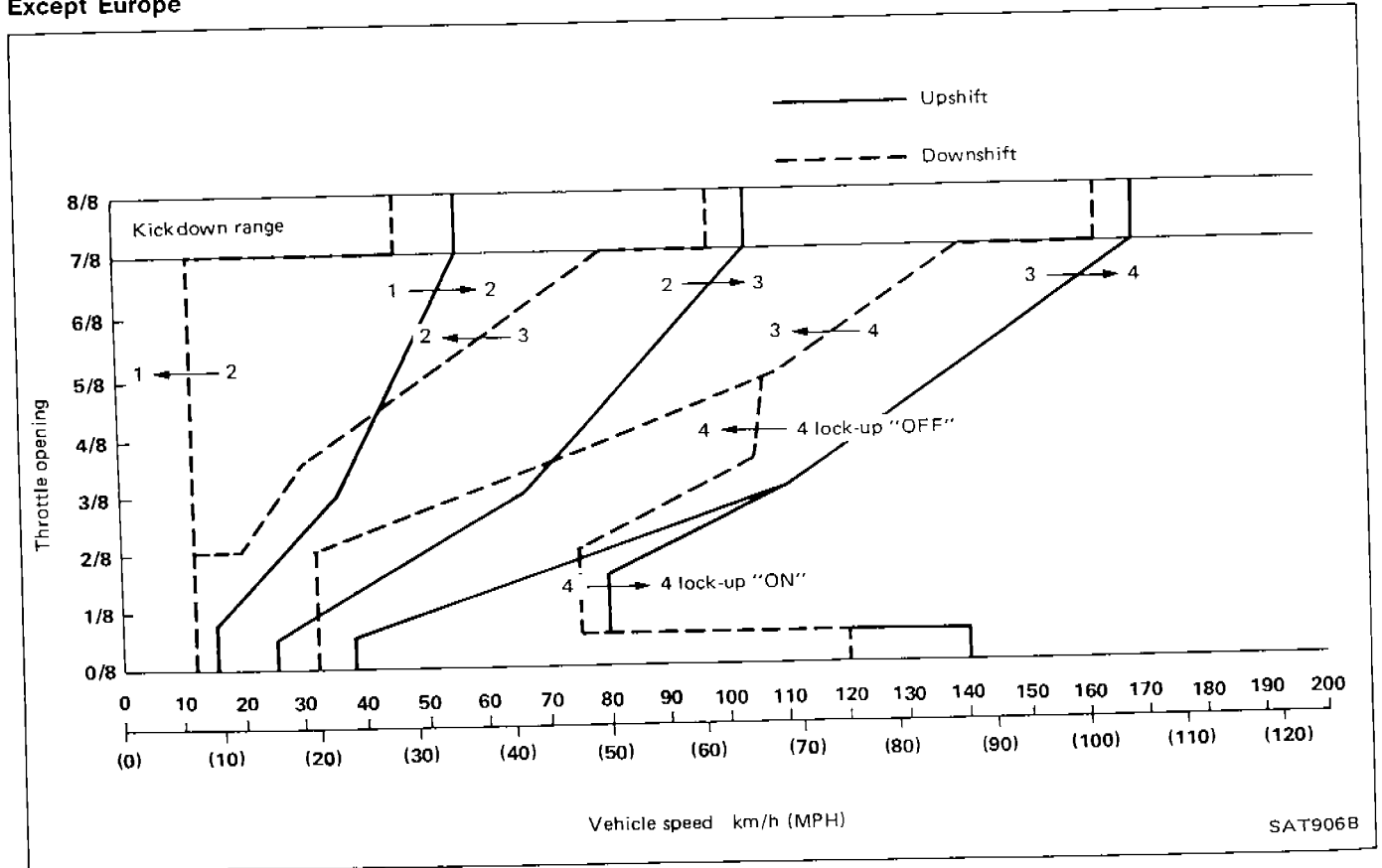

SAT906B

TROUBLE DIAGNOSES

A/T Electrical Parts Location

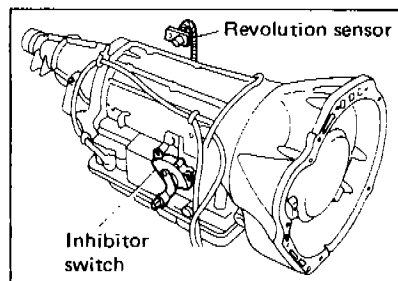
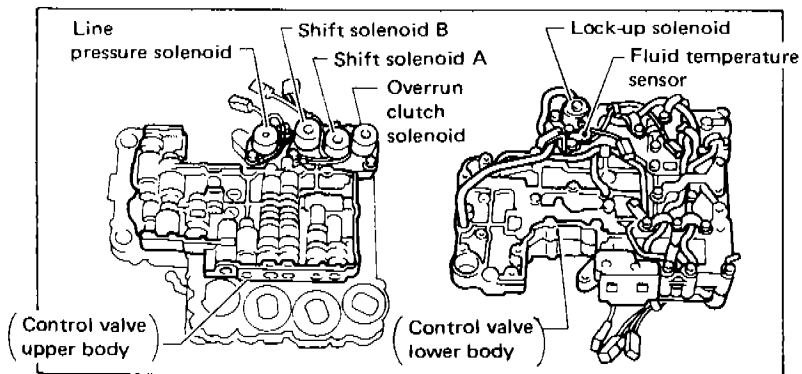
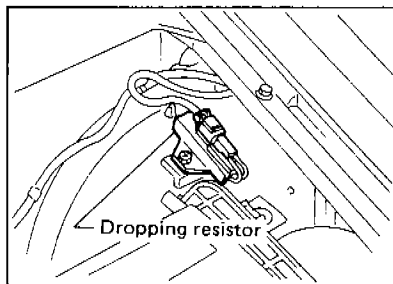
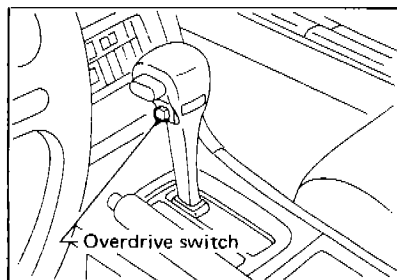
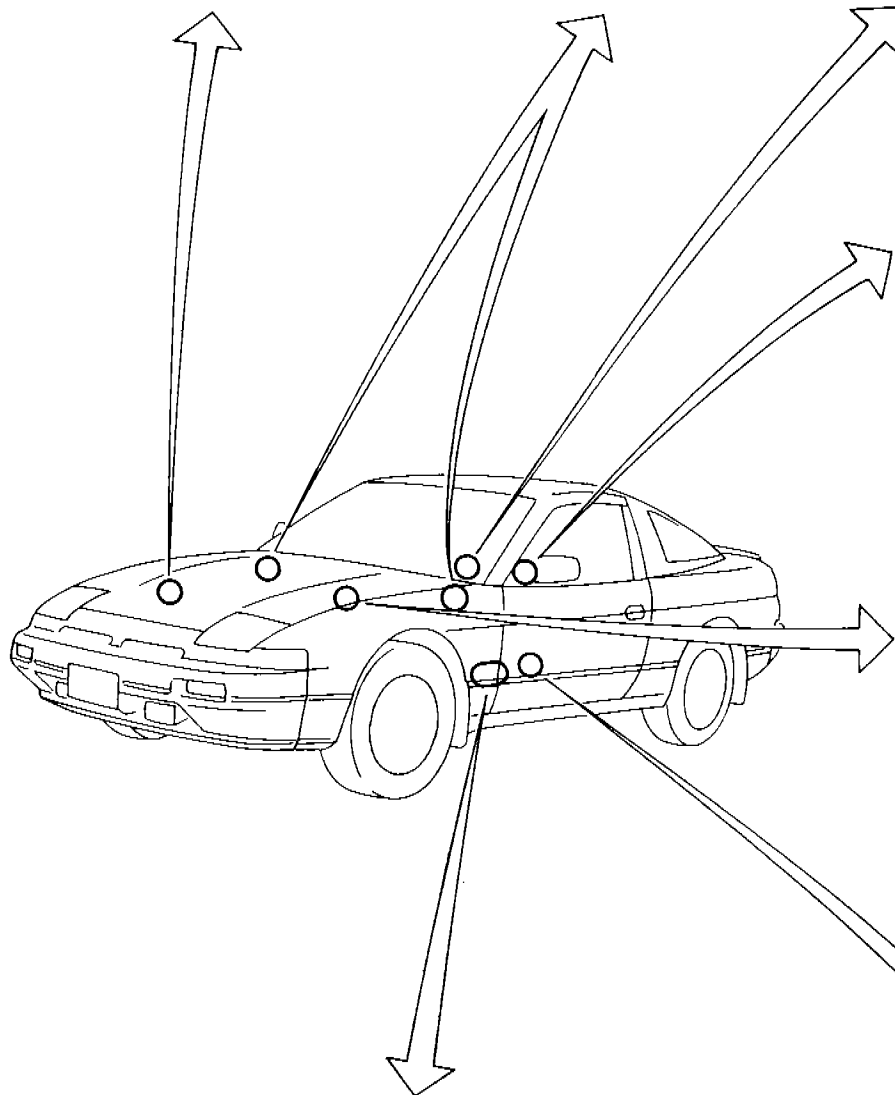
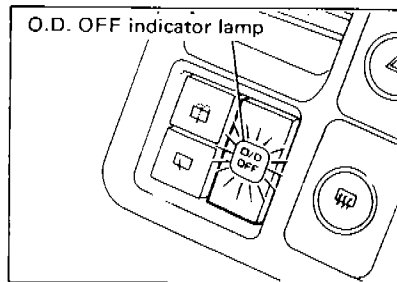
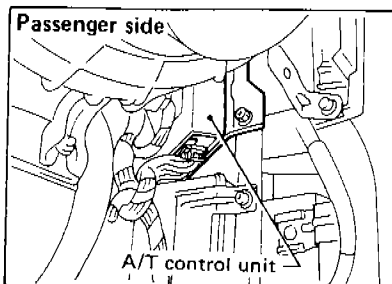
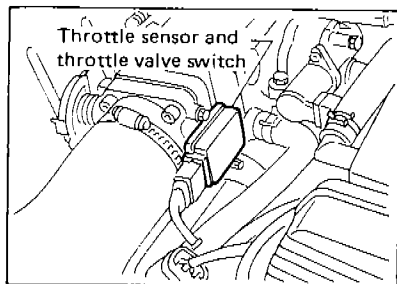

SAT907B

TROUBLE DIAGNOSES

A/T Electrical Parts Location (Cont'd)

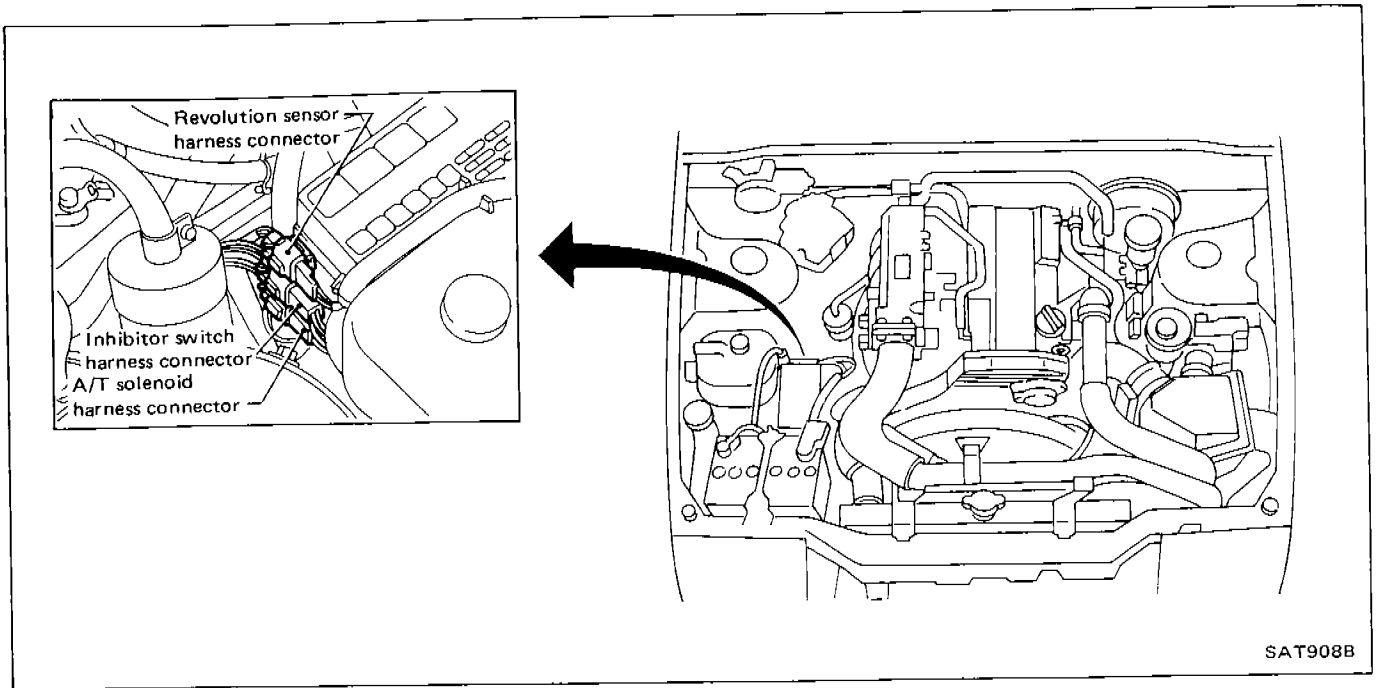

TROUBLE DIAGNOSES

Circuit Diagram for Quick Pinpoint Check

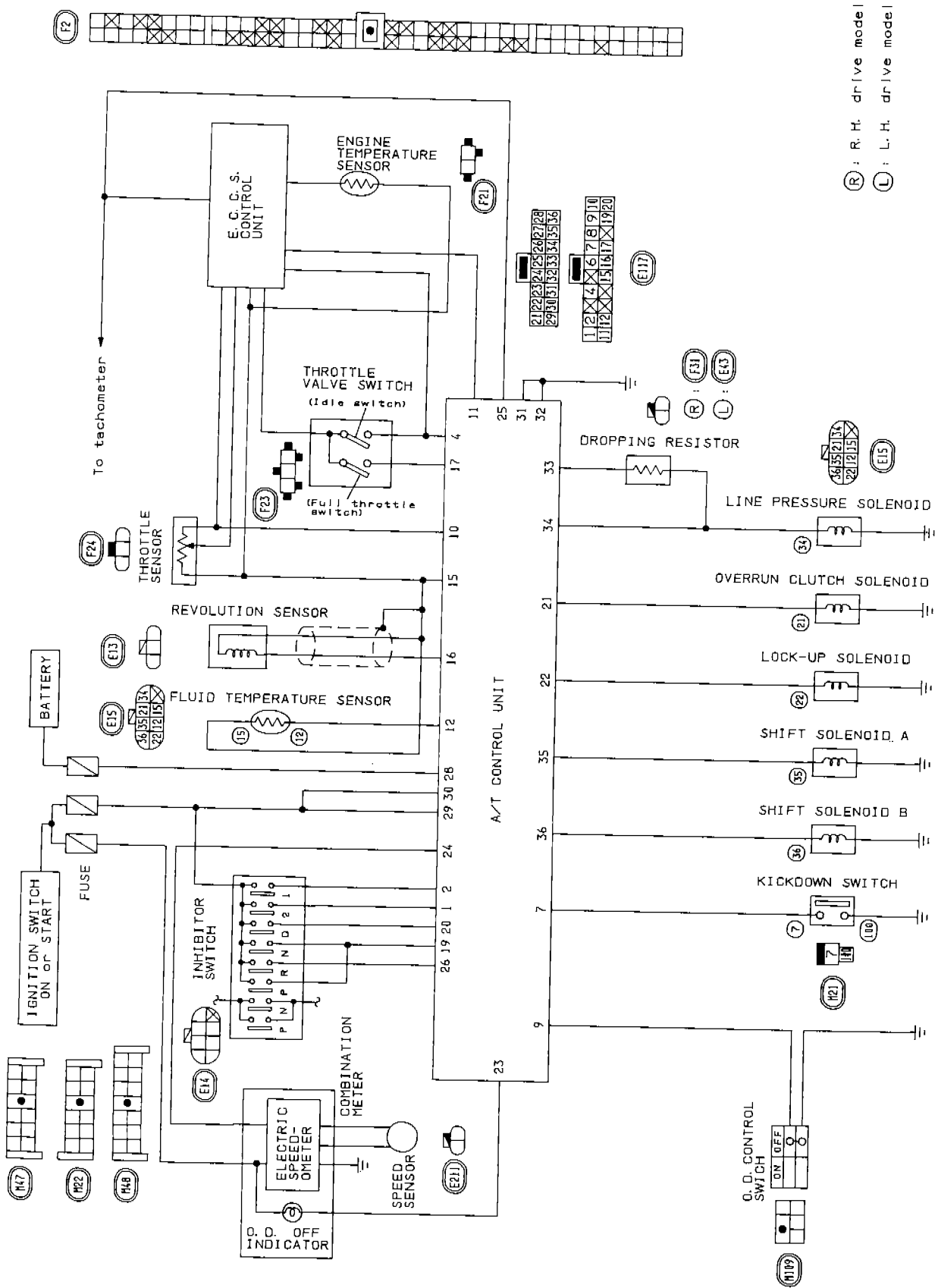

SAT903B

TROUBLE DIAGNOSES

Wiring Diagram

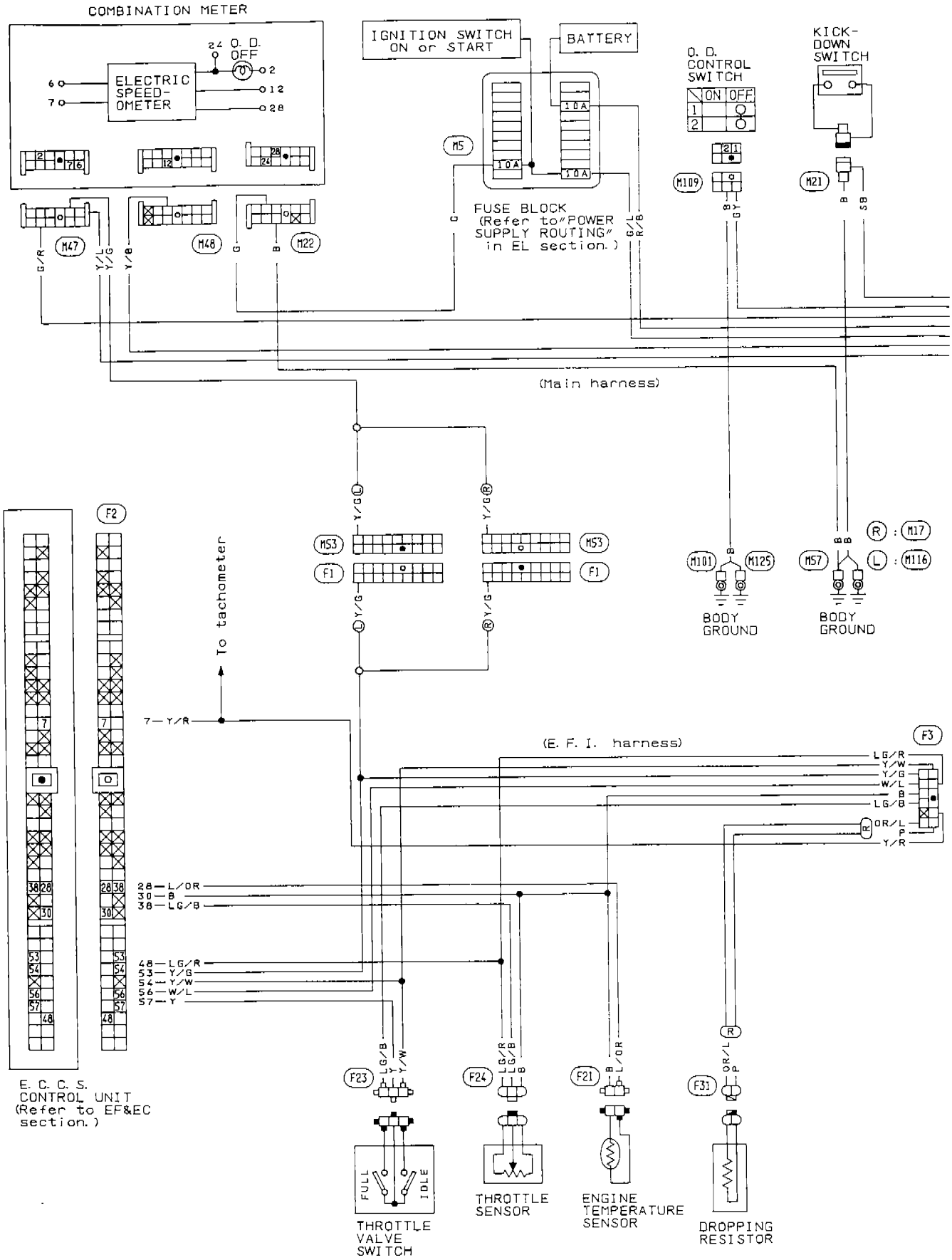

TROUBLE DIAGNOSES

Wiring Diagram (Cont'd)

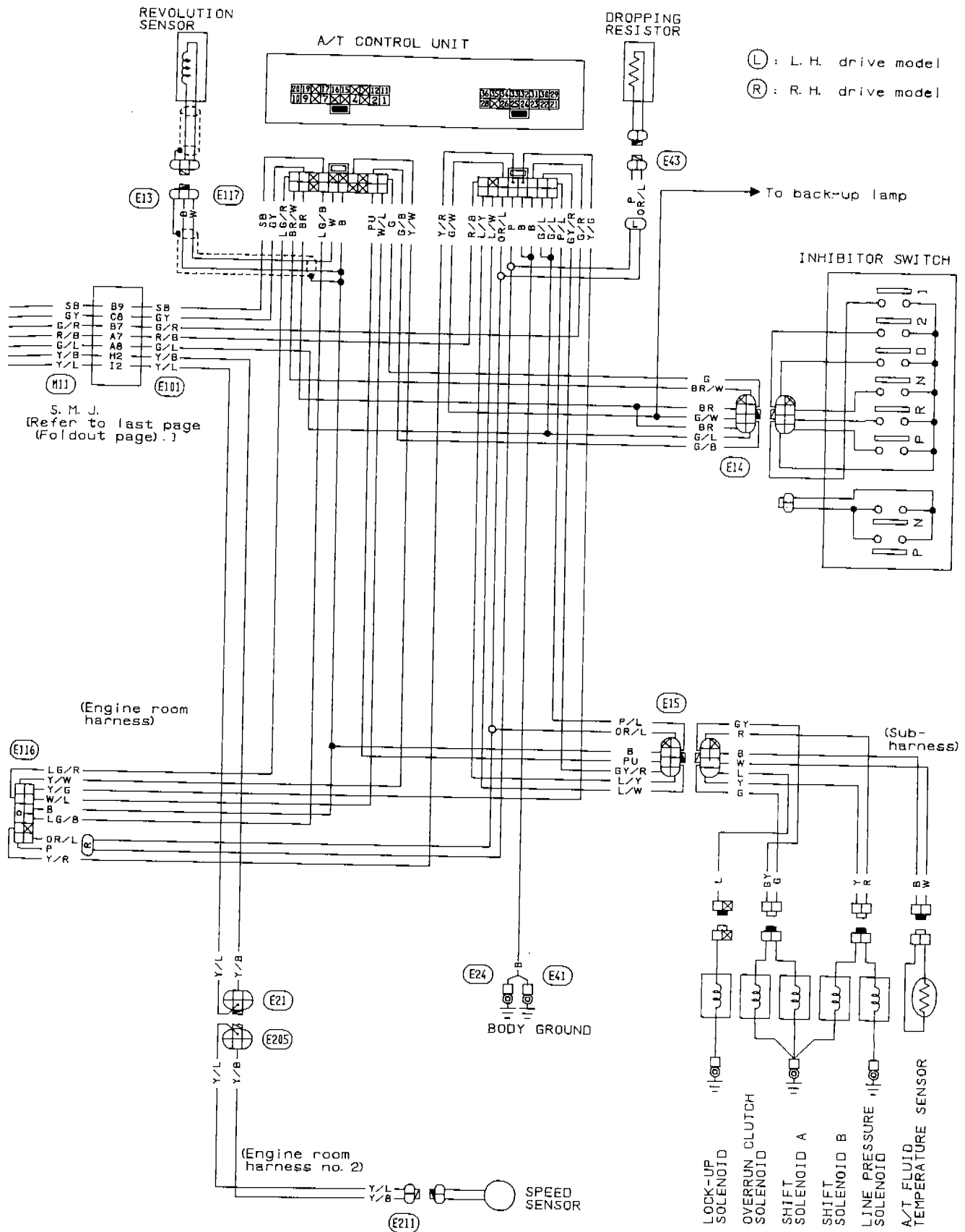

SAT904B

TROUBLE DIAGNOSES

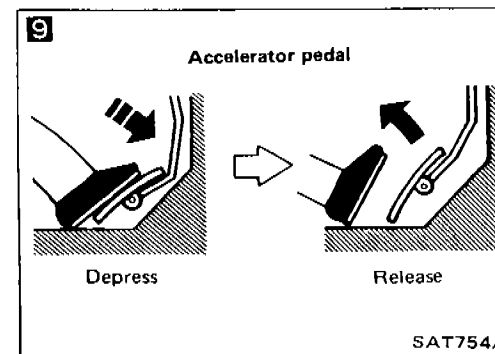
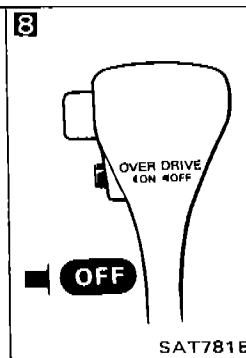
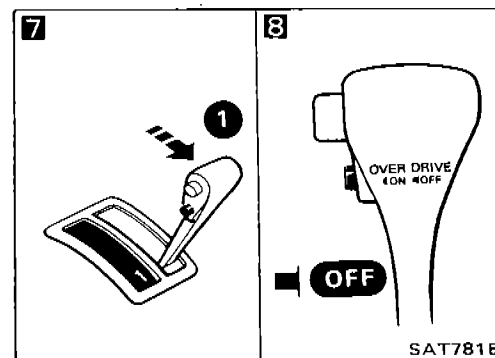
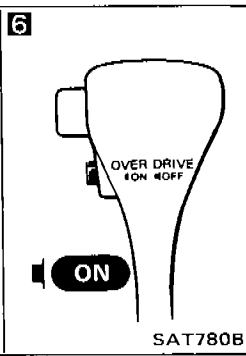
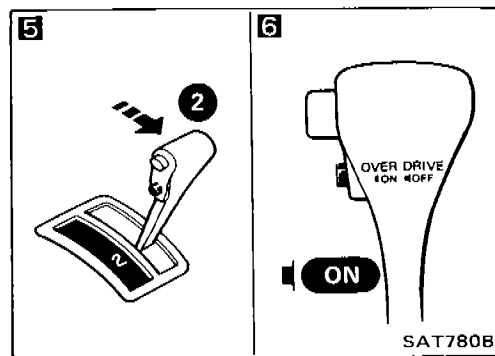
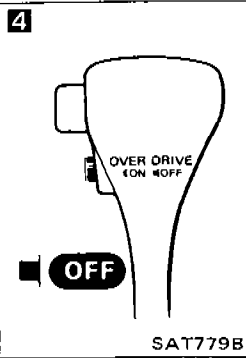
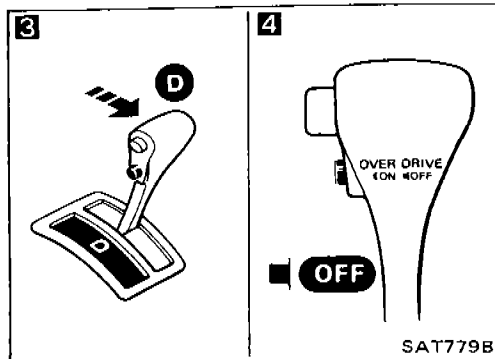
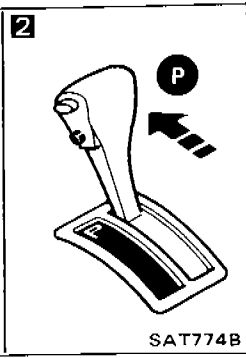
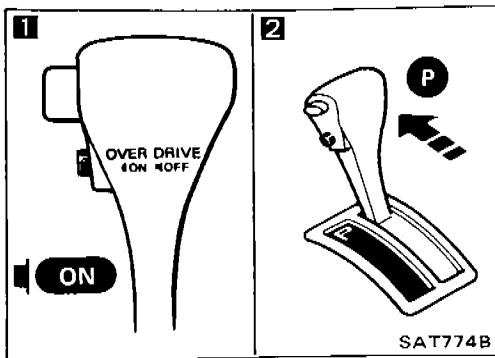

Self-diagnosis

SELF-DIAGNOSTIC PROCEDURE

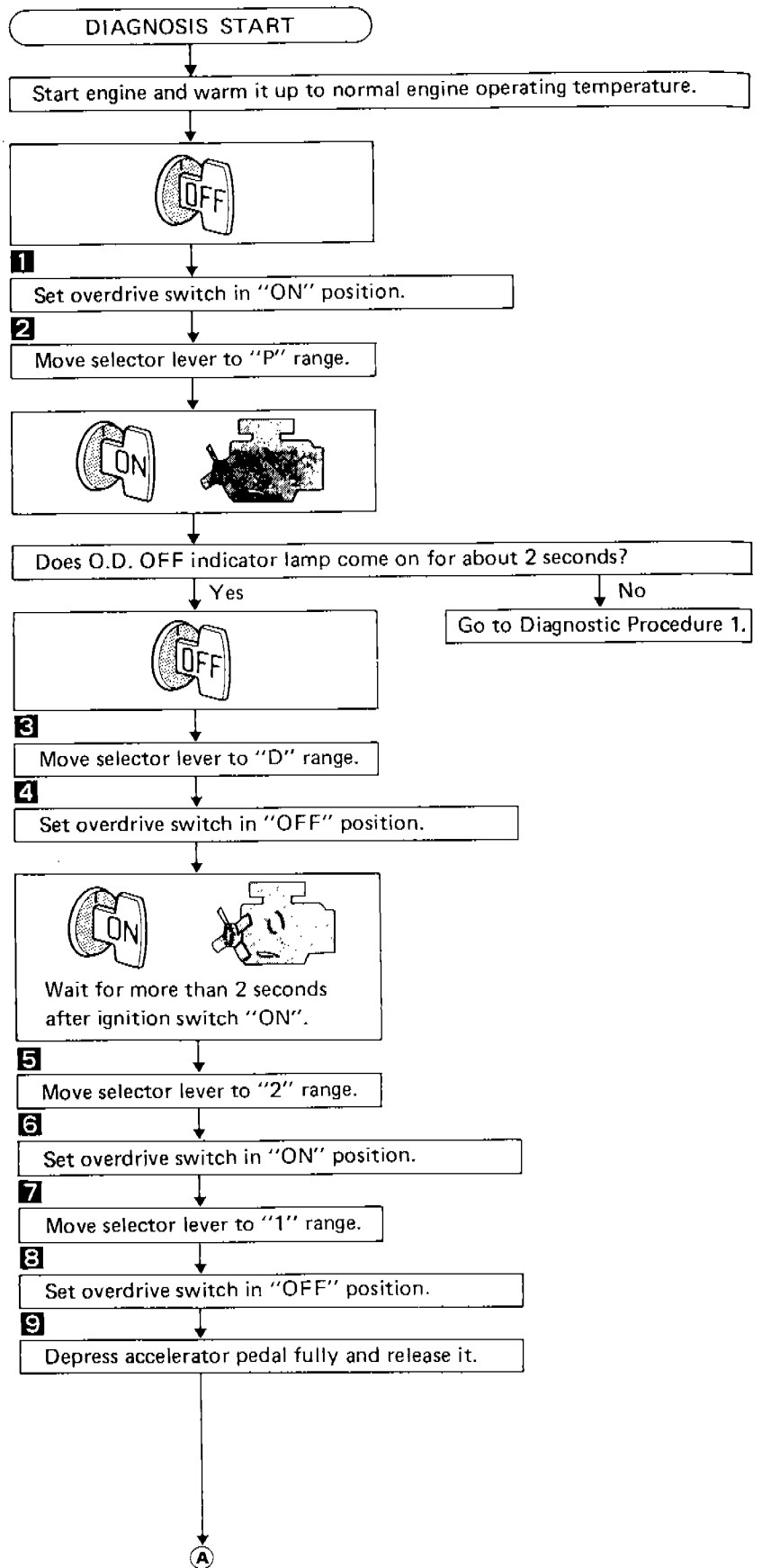

TROUBLE DIAGNOSES



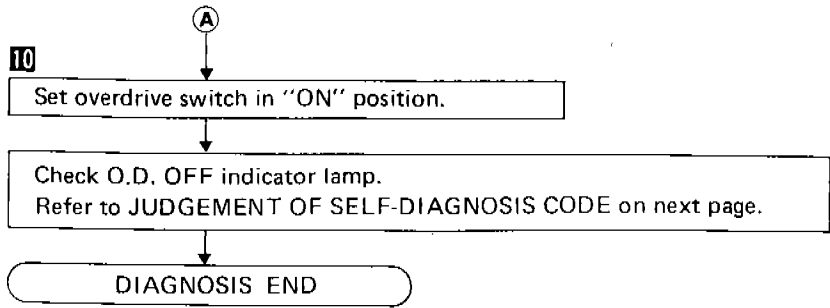
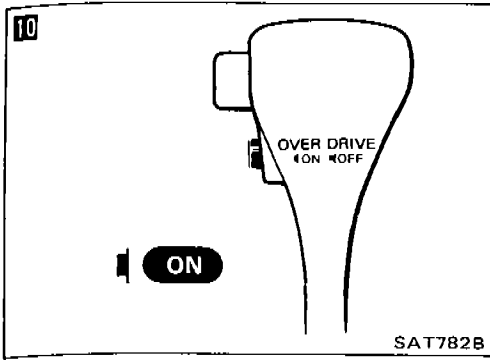



Self-diagnosis (Cont'd)

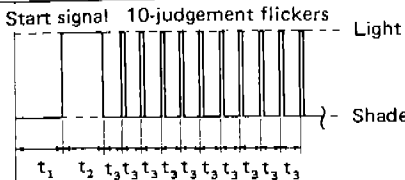

TROUBLE DIAGNOSES

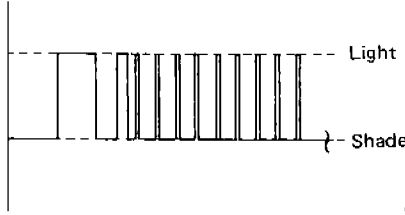
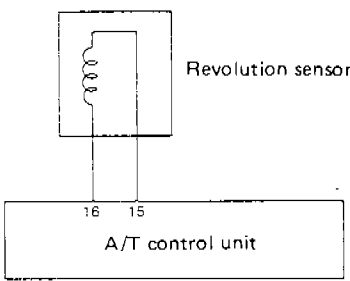
Self-diagnosis (Cont'd)

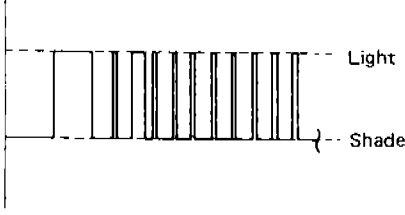
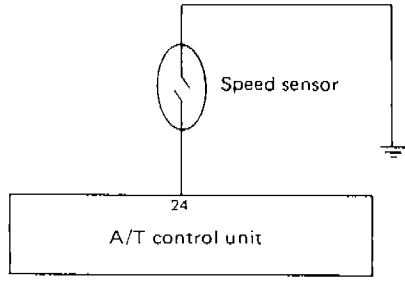

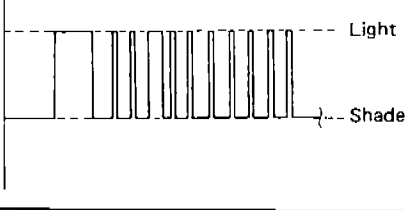
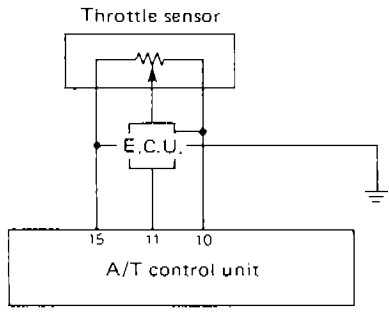





JUDGEMENT OF SELF-DIAGNOSIS CODE

| O.D. OFF indicator lamp: | Damaged circuit |
|--------------------------------------------------------------------------------------------------------------------------------------------------------------------------------------------------------------------------------------------------------------------------------------------------------------------------------------------------------------------------------------------------------------------------------------------------------------------------------------------------------------------------------------------------------------------------------------------------------------------------------------------------------------------------------------------------------------------------------------------------------|---------------------------------------------------------------------------------------------------------------------------------------------------------------------------------------------------------------------------------------------------------------------------------------------------------------------------------------------------------------------------------------------------|
| <p style="text-align: center;">All judgement flickers are same.</p> <div style="text-align: center;">  <p>O/D OFF</p> </div> <div style="border: 1px solid black; padding: 2px; width: fit-content; margin: 5px auto;">Self-diagnosis start</div> <div style="text-align: center;">  <p>Start signal 10-judgement flickers Light Shade</p> <p>t_1 t_2 t_3 t_3 t_3 t_3 t_3 t_3 t_3 t_3</p> </div> <p style="text-align: right;">SAT723B</p> | <p>All circuits that can be confirmed by self-diagnosis are O.K.</p> |
| <p style="text-align: center;">1st judgement flicker is longer than others.</p> <div style="text-align: center;">  <p>O/D OFF</p> </div> <div style="text-align: center;">  <p>Light Shade</p> </div> <p style="text-align: right;">SAT724B</p> | <p>Revolution sensor circuit is short-circuited or disconnected.</p> <div style="text-align: center;">  <p>Revolution sensor</p> <p>16 15</p> <p>A/T control unit</p> </div> <p style="text-align: center;">➡ Go to REVOLUTION SENSOR CIRCUIT CHECK.</p> <p style="text-align: right;">SAT140B</p> |
| <p style="text-align: center;">2nd judgement flicker is longer than others.</p> <div style="text-align: center;">  <p>O/D OFF</p> </div> <div style="text-align: center;">  <p>Light Shade</p> </div> <p style="text-align: right;">SAT725B</p> | <p>Speed sensor circuit is short-circuited or disconnected.</p> <div style="text-align: center;">  <p>Speed sensor</p> <p>24</p> <p>A/T control unit</p> </div> <p style="text-align: center;">➡ Go to SPEED SENSOR CIRCUIT CHECK.</p> <p style="text-align: right;">SAT760A</p> |
| <p style="text-align: center;">3rd judgement flicker is longer than others.</p> <div style="text-align: center;">  <p>O/D OFF</p> </div> <div style="text-align: center;">  <p>Light Shade</p> </div> <p style="text-align: right;">SAT726B</p> | <p>Throttle sensor circuit is short-circuited or disconnected.</p> <div style="text-align: center;">  <p>Throttle sensor</p> <p>E.C.U.</p> <p>15 11 10</p> <p>A/T control unit</p> </div> <p style="text-align: center;">➡ Go to THROTTLE SENSOR CIRCUIT CHECK.</p> <p style="text-align: right;">SAT761A</p> |

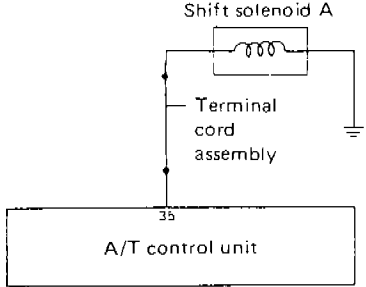
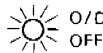
$t_1 = 2.5$ seconds $t_2 = 2.0$ seconds $t_3 = 1.0$ second

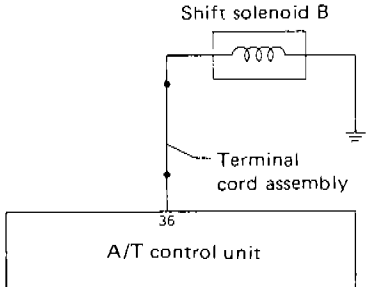
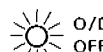
TROUBLE DIAGNOSES

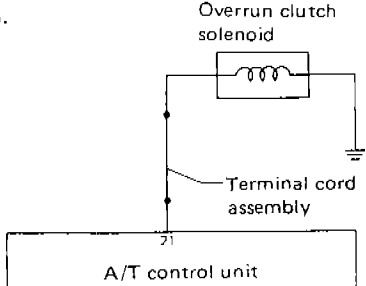
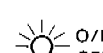
Self-diagnosis (Cont'd)

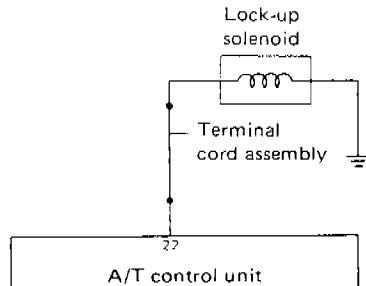
| O.D. OFF indicator lamp: | Damaged circuit |
|--------------------------------------------------------------------------------------------------------------------------------------------------------------------------------------------------------------------------------------------------------------------|---------------------------------------------------------------------------------------------------------------------------------------------------------------------------------------------------------------------------------------------|
| <p>4th judgement flicker is longer than others.</p>  <p>Self-diagnosis start</p>  <p>SAT727B</p> | <p>Shift solenoid A circuit is short-circuited or disconnected.</p>  <p>➡ Go to SHIFT SOLENOID A CIRCUIT CHECK.</p> <p>SAT766A</p> |
| <p>5th judgement flicker is longer than others.</p>   <p>SAT728B</p> | <p>Shift solenoid B circuit is short-circuited or disconnected.</p>  <p>➡ Go to SHIFT SOLENOID B CIRCUIT CHECK.</p> <p>SAT767A</p> |
| <p>6th judgement flicker is longer than others.</p>   <p>SAT729B</p> | <p>Overrun clutch solenoid circuit is short-circuited or disconnected.</p>  <p>➡ Go to OVERRUN CLUTCH SOLENOID CIRCUIT CHECK.</p> <p>SAT768A</p> |
| <p>7th judgement flicker is longer than others.</p>   <p>SAT730B</p> | <p>Lock-up solenoid circuit is short-circuited or disconnected.</p>  <p>➡ Go to LOCK-UP SOLENOID CIRCUIT CHECK.</p> <p>SAT769A</p> |

TROUBLE DIAGNOSES

Self-diagnosis (Cont'd)

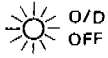
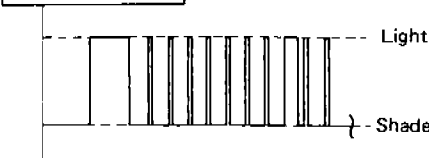
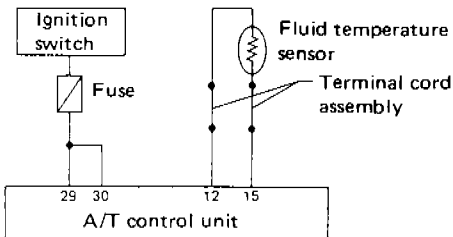
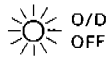
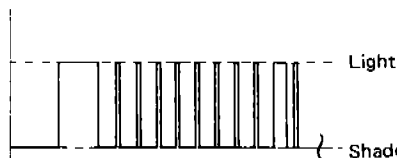
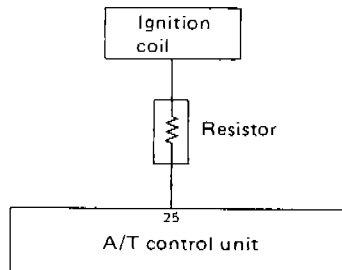
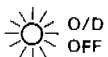
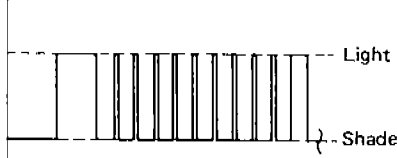
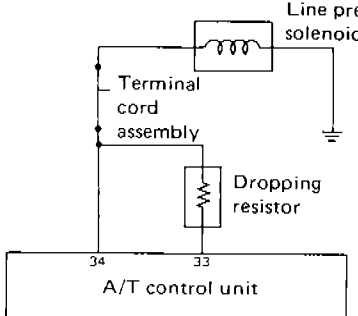
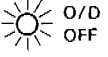
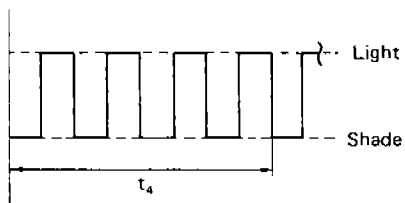
| O.D. OFF indicator lamp: | Damaged circuit |
|-----------------------------------------------------------------------------------------------------------------------------------------------------------------------------------------------------------------------------------------------------------------------------------------------|-------------------------------------------------------------------------------------------------------------------------------------------------------------------------------------------------------------------------------------------------------------------------------------------------------------------------------------------|
| <p>8th judgement flicker is longer than others.</p>  <p>Self-diagnosis start</p>  <p style="text-align: right;">SAT731B</p> | <p>Fluid temperature sensor is disconnected or A/T control unit power source circuit is damaged.</p>  <p>➡ Go to FLUID TEMPERATURE SENSOR CIRCUIT AND A/T CONTROL UNIT POWER SOURCE CIRCUIT CHECK.</p> <p style="text-align: right;">SAT143B</p> |
| <p>9th judgement flicker is longer than others.</p>   <p style="text-align: right;">SAT733B</p> | <p>Engine revolution signal circuit is short-circuited or disconnected.</p>  <p>➡ Go to ENGINE REVOLUTION SIGNAL CIRCUIT CHECK.</p> <p style="text-align: right;">SAT624B</p> |
| <p>10th judgement flicker is longer than others.</p>   <p style="text-align: right;">SAT732B</p> | <p>Line pressure solenoid circuit is short-circuited or disconnected.</p>  <p>➡ Go to LINE PRESSURE SOLENOID CIRCUIT CHECK.</p> <p style="text-align: right;">SAT776A</p> |
| <p>Flickers as shown below:</p>   <p style="text-align: right;">SAT734B</p> | <p>Battery power is low. Battery has been disconnected for a long time. Battery is connected conversely. (When reconnecting A/T control unit connectors. — This is not a problem.)</p> |

$t_4 = 1.0$ second

TROUBLE DIAGNOSES

Self-diagnosis (Cont'd)

| O.D. OFF indicator lamp: | Damaged circuit |
|--------------------------------------------------------------------------------------------------------------------------------------------------------------------------------------------------------------------------------------------------------------------------------|--------------------------------------------------------------------------------------------------------------------------------------------------------------------------------------------------------------------------------------------------------------------|
| <p>Does not come on.</p> <p>○ O/D OFF</p> <div data-bbox="220 367 427 434" style="border: 1px solid black; padding: 2px;"> Self-diagnosis start </div> <p>----- Light</p> <p>----- Shade</p> <p style="text-align: right;">SAT157C</p> | <p>Inhibitor switch, overdrive switch, kickdown switch or idle switch circuit is disconnected or A/T control unit is damaged.</p> <p> ➡ Go to INHIBITOR, OVERDRIVE, KICKDOWN AND IDLE SWITCH CIRCUIT CHECKS. </p> <p style="text-align: right;">SAT007C</p> |

TROUBLE DIAGNOSES

Self-diagnosis (Cont'd)

REVOLUTION SENSOR CIRCUIT CHECK

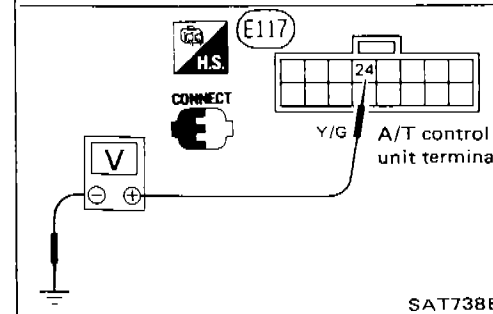
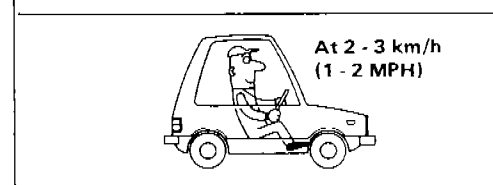
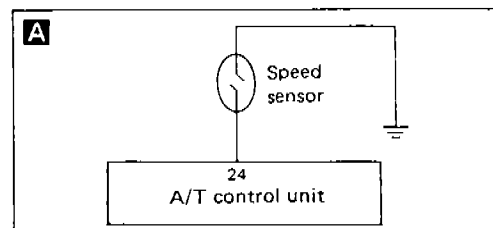
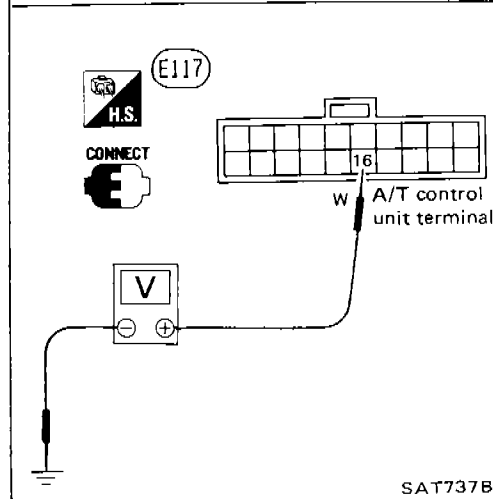
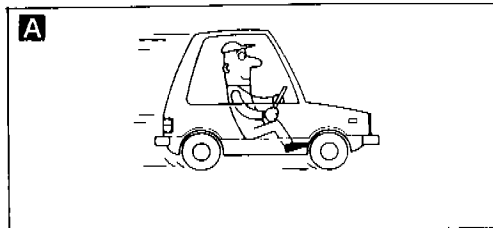
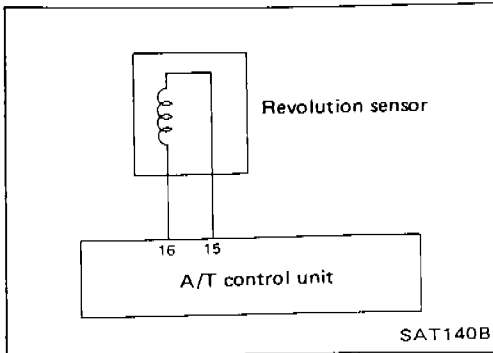

CHECK REVOLUTION SENSOR. — Refer to "Electrical Components Inspection".

N.G.

Repair or replace revolution sensor.

O.K.

A

CHECK INPUT SIGNAL.

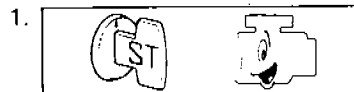

2. Check voltage between A/T control unit terminal ①⑥ and ground while driving.
(Measure with A.C. range.)

Voltage:

At 0 km/h (0 MPH): 0V

At 30 km/h (19 MPH):

1V or more

(Voltage rises gradually in response to vehicle speed)

N.G.

Check the following items.

- Harness continuity between A/T control unit and revolution sensor (Main harness)
- Harness continuity between revolution sensor and E.C.U. (Main harness)
- Ground circuit for E.C.U. — Refer to section EF & EC.

O.K.

Perform self-diagnosis again after driving for a while.

N.G.

1. Perform A/T control unit input/output signal inspection.
2. If N.G., recheck A/T control unit pin terminals for damage or connection of A/T control unit harness connector.

O.K.

INSPECTION END

SPEED SENSOR CIRCUIT CHECK

A

CHECK INPUT SIGNAL.



2. Check voltage between A/T control unit terminal ②④ and ground while driving at 2 to 3 km/h (1 to 2 MPH) for 1 m (3 ft) or more.

Voltage: Varies from 0V to 5V

N.G.

Check the following items.

- Speed sensor and ground circuit for speed sensor — Refer to section EL.
- Harness continuity between A/T control unit and speed sensor (Main harness)

O.K.

Perform self-diagnosis again after driving for a while.

N.G.

1. Perform A/T control unit input/output signal inspection.
2. If N.G., recheck A/T control unit pin terminals for damage or connection of A/T control unit harness connector.

O.K.

INSPECTION END

TROUBLE DIAGNOSES

Self-diagnosis (Cont'd)

THROTTLE SENSOR CIRCUIT CHECK

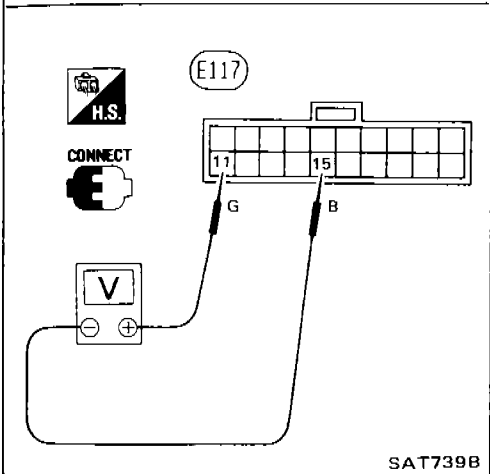
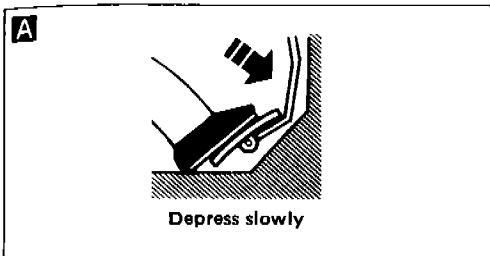
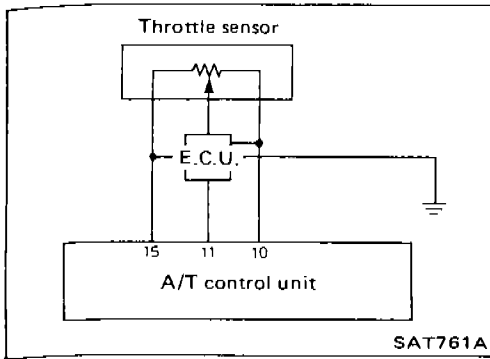

Perform self-diagnosis (Mode III) for engine control.

N.G.

Check throttle sensor circuit for engine control. — Refer to section EF & EC.

O.K.

A

CHECK INPUT SIGNAL.

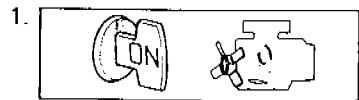

N.G.

Check harness continuity between E.C.U. and A/T control unit regarding throttle sensor circuit. (Main harness)

2. Check voltage between A/T control unit terminals ⑪ and ⑮ while accelerator pedal is depressed slowly.

Voltage:

Fully-closed throttle:

0.2 - 0.6V

Fully-open throttle:

2.9 - 3.9V

(Voltage rises gradually in response to throttle valve opening.)

O.K.

Perform self-diagnosis again after driving for a while.

N.G.

1. Perform A/T control unit input/output signal inspection.
2. If N.G., recheck A/T control unit pin terminals for damage or connection of A/T control unit harness connector.

O.K.

INSPECTION END

TROUBLE DIAGNOSES

Self-diagnosis (Cont'd)

SHIFT SOLENOID A CIRCUIT CHECK

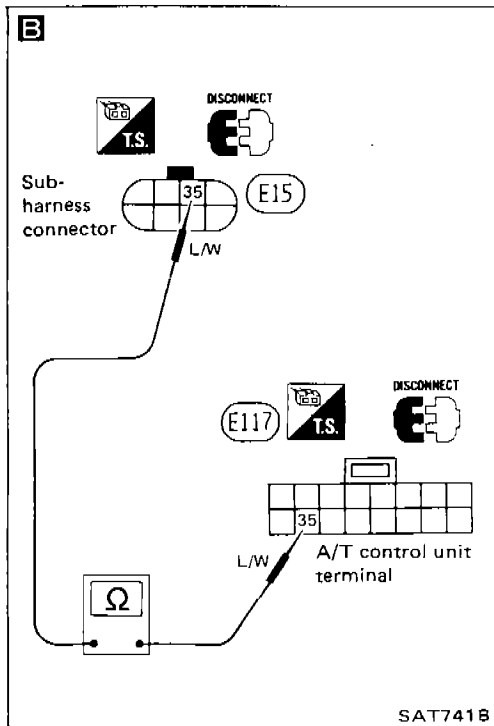
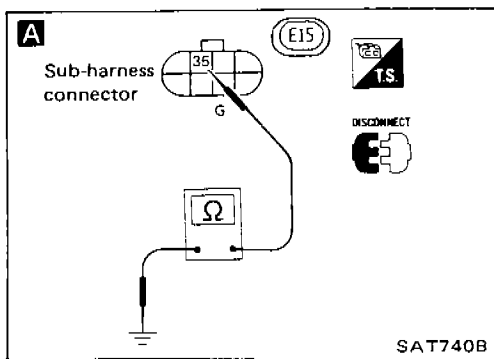
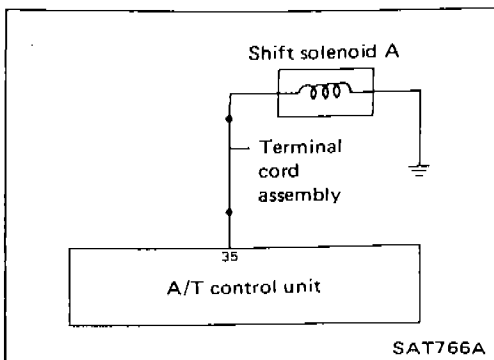

A

CHECK GROUND CIRCUIT.

- 1.
2. Disconnect terminal cord assembly connector in engine compartment.
3. Check resistance between terminal 35 and ground.
Resistance: 20 - 30Ω

N.G.

1. Remove control valve assembly. — Refer to "ON-VEHICLE SERVICE".
2. Check the following items.
 - Shift solenoid A — Refer to "Electrical Components Inspection".
 - Harness continuity of terminal cord assembly

O.K.

B

CHECK POWER SOURCE CIRCUIT.

- 1.
2. Disconnect A/T control unit 16-pin connector.
3. Check resistance between terminal 35 and A/T control unit terminal 35.
Resistance:
Approximately 0Ω
4. Reinstall any part removed.

N.G.

- Repair or replace harness between A/T control unit and terminal cord assembly. (Main harness)

O.K.

Perform self-diagnosis after driving for a while.

N.G.

1. Perform A/T control unit input/output signal inspection.
2. If N.G., recheck A/T control unit pin terminals for damage or connection of A/T control unit harness connector.

O.K.

INSPECTION END

TROUBLE DIAGNOSES

Self-diagnosis (Cont'd)

SHIFT SOLENOID B CIRCUIT CHECK

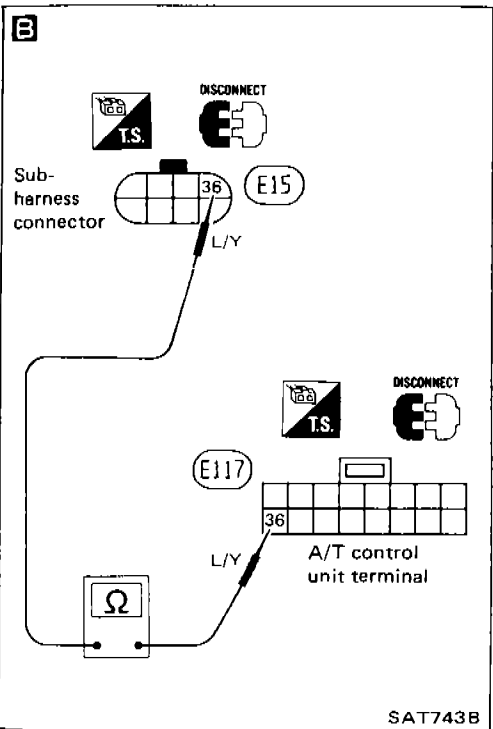
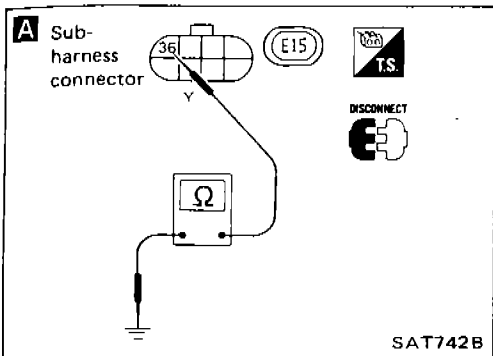
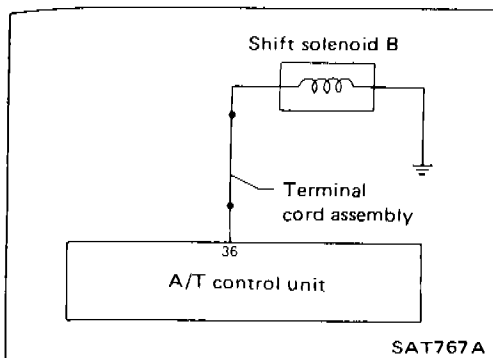

A

CHECK GROUND CIRCUIT.

1. 
2. Disconnect terminal cord assembly connector in engine compartment.
3. Check resistance between terminal 36 and ground.
Resistance: 20 - 30Ω

N.G.

1. Remove control valve assembly. — Refer to "ON-VEHICLE SERVICE".
2. Check the following items.
 - Shift solenoid B — Refer to "Electrical Components Inspection".
 - Harness continuity of terminal cord assembly

O.K.

B

CHECK POWER SOURCE CIRCUIT.

1. 
2. Disconnect A/T control unit 16-pin connector.
3. Check resistance between terminal 36 and A/T control unit terminal 36.
Resistance:
Approximately 0Ω
4. Reinstall any part removed.

N.G.

- Repair or replace harness between A/T control unit and terminal cord assembly. (Main harness)

O.K.

Perform self-diagnosis after driving for a while.

N.G.

1. Perform A/T control unit input/output signal inspection.
2. If N.G., recheck A/T control unit pin terminals for damage or connection of A/T control unit harness connector.

O.K.

INSPECTION END

TROUBLE DIAGNOSES

Self-diagnosis (Cont'd)

OVERRUN CLUTCH SOLENOID CIRCUIT CHECK

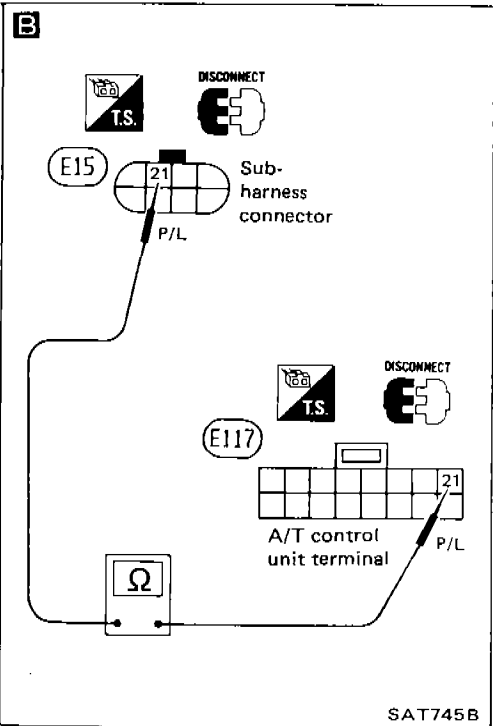
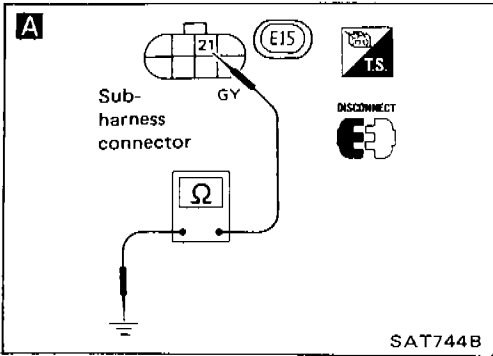
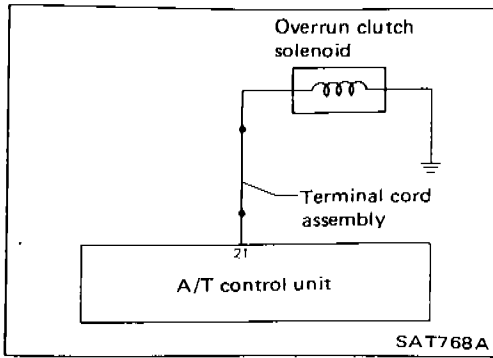

A

CHECK GROUND CIRCUIT.

- 1.
2. Disconnect terminal cord assembly connector in engine compartment.
3. Check resistance between terminal 21 and ground.
Resistance: 20 - 30Ω

N.G.

1. Remove control valve assembly. — Refer to "ON-VEHICLE SERVICE".
2. Check the following items.
 - Overrun clutch solenoid. — Refer to "Electrical Components Inspection".
 - Harness continuity of terminal cord assembly

B

CHECK POWER SOURCE CIRCUIT.

- 1.
2. Disconnect A/T control unit 16-pin connector.
3. Check resistance between terminal 21 and A/T control unit terminal 21.
Resistance: Approximately 0Ω
4. Reinstall any part removed.

N.G.

- Repair or replace harness between A/T control unit and terminal cord assembly. (Main harness)

Perform self-diagnosis after driving for a while.

O.K.

INSPECTION END

N.G.

1. Perform A/T control unit input/output signal inspection.
2. If N.G., recheck A/T control unit pin terminals for damage or connection of A/T control unit harness connector.

TROUBLE DIAGNOSES

Self-diagnosis (Cont'd)

LOCK-UP SOLENOID CIRCUIT CHECK

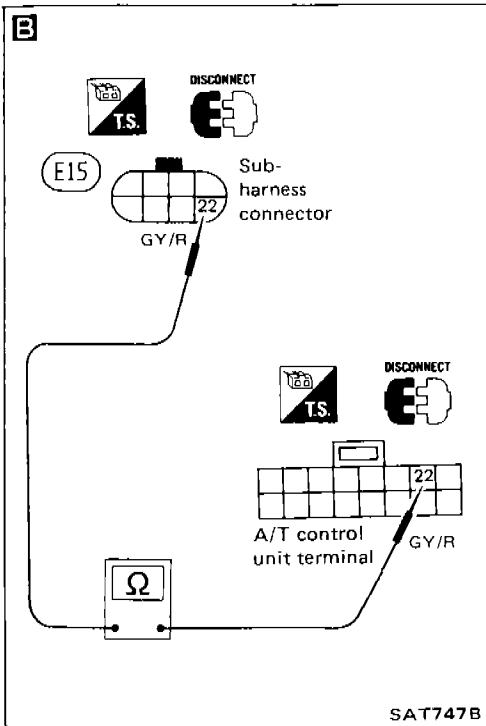
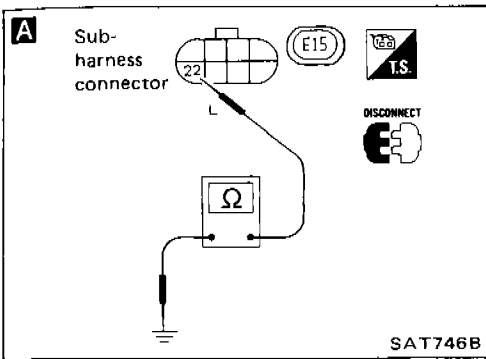
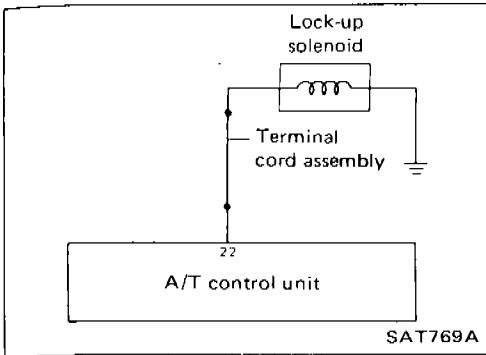

A

CHECK GROUND CIRCUIT.

- 1.
2. Disconnect terminal cord assembly connector in engine compartment.
3. Check resistance between terminal 22 and ground.
Resistance: 2.5 - 5Ω

N.G.

1. Remove oil pan. — Refer to "ON-VEHICLE SERVICE".
2. Check the following items.
 - Lock-up solenoid — Refer to "Electrical Components Inspection".
 - Harness continuity of terminal cord assembly

O.K.

B

CHECK POWER SOURCE CIRCUIT.

- 1.
2. Disconnect A/T control unit 16-pin connector.
3. Check resistance between terminal 22 and A/T control unit terminal 22.
Resistance: Approximately 0Ω
4. Reinstall any part removed.

N.G.

Repair or replace harness between A/T control unit and terminal cord assembly. (Main harness)

O.K.

Perform self-diagnosis after driving for a while.

O.K.

INSPECTION END

N.G.

1. Perform A/T control unit input/output signal inspection.
2. If N.G., recheck A/T control unit pin terminals for damage or connection of A/T control unit harness connector.

TROUBLE DIAGNOSES

Self-diagnosis (Cont'd)

FLUID TEMPERATURE SENSOR CIRCUIT AND A/T CONTROL UNIT POWER SOURCE CIRCUIT CHECKS

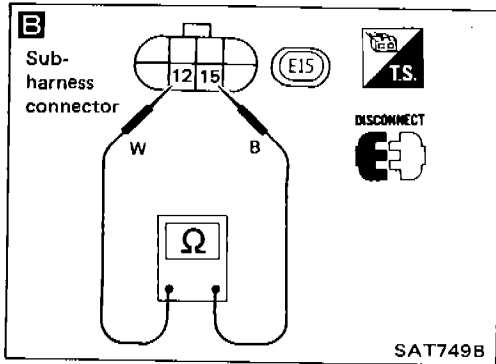
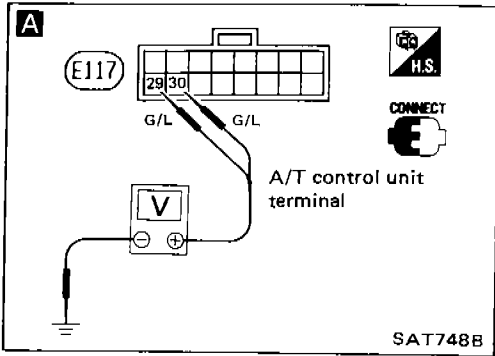
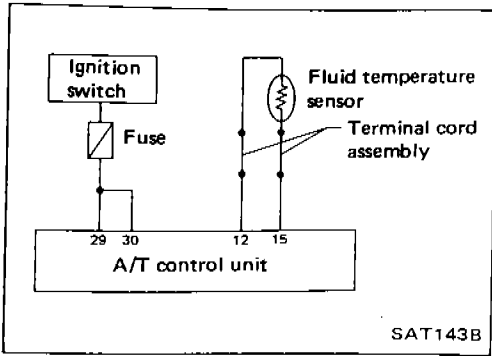

A

CHECK A/T CONTROL UNIT POWER SOURCE.

-
- Check voltage between A/T control unit terminals 29, 30 and ground. Battery voltage should exist.

N.G.

- Check the following items.
- Harness continuity between ignition switch and A/T control unit (Main harness)
 - Ignition switch and fuse – Refer to section EL.

B

CHECK FLUID TEMPERATURE SENSOR WITH TERMINAL CORD ASSEMBLY

-
- Disconnect terminal cord assembly connector in engine compartment.
- Check resistance between terminals 12 and 15 when A/T is cold.
Resistance:
Cold [20°C (68°F)]
Approximately 2.5 kΩ
- Reinstall any part removed.

N.G.

1. Remove oil pan.
2. Check the following items.
 - Fluid temperature sensor – Refer to "Electrical Components Inspection".
 - Harness continuity of terminal cord assembly

O.K.

A

TROUBLE DIAGNOSES

Self-diagnosis (Cont'd)

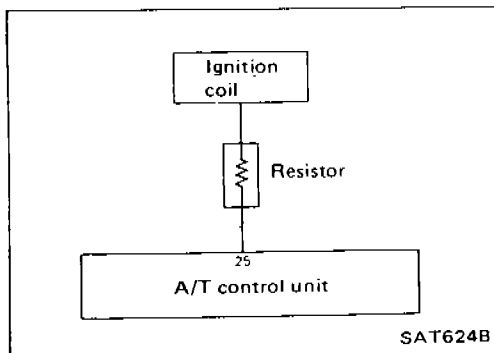
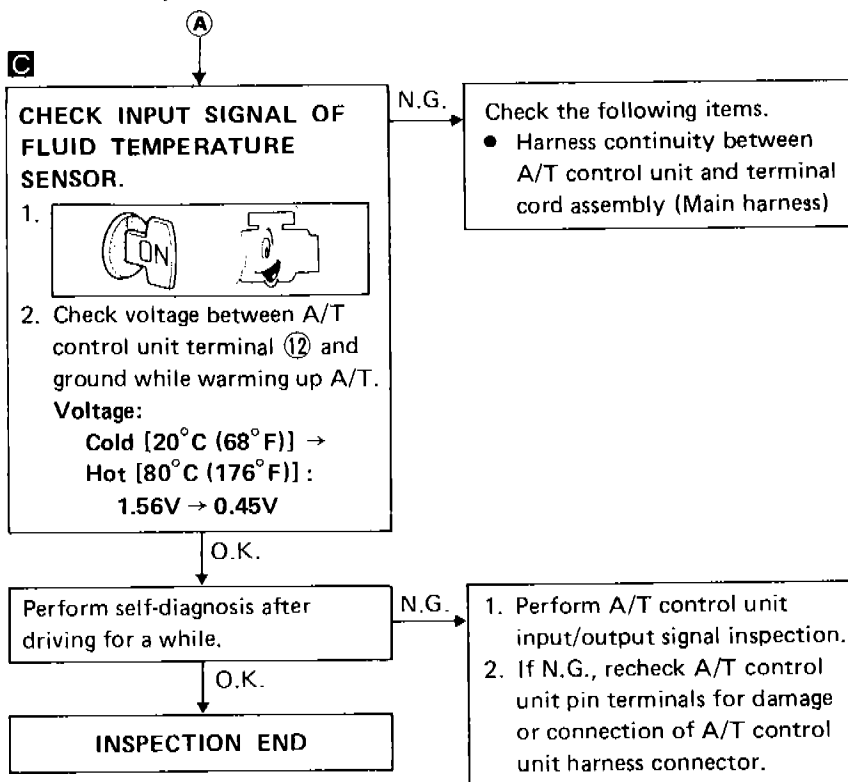
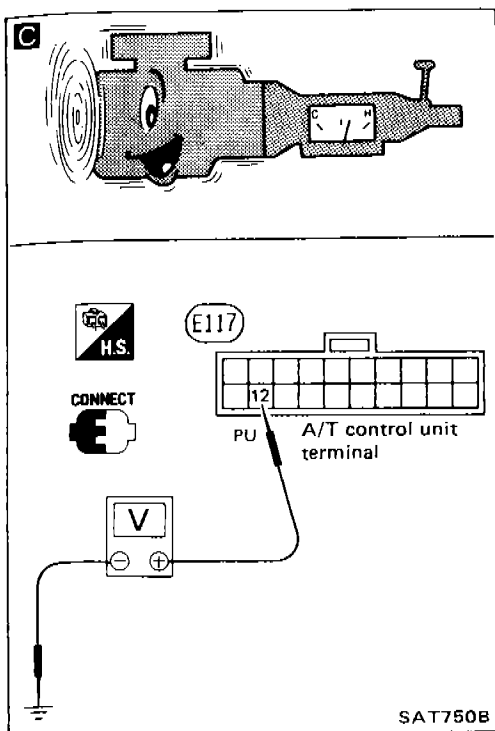

ENGINE REVOLUTION SIGNAL CIRCUIT CHECK

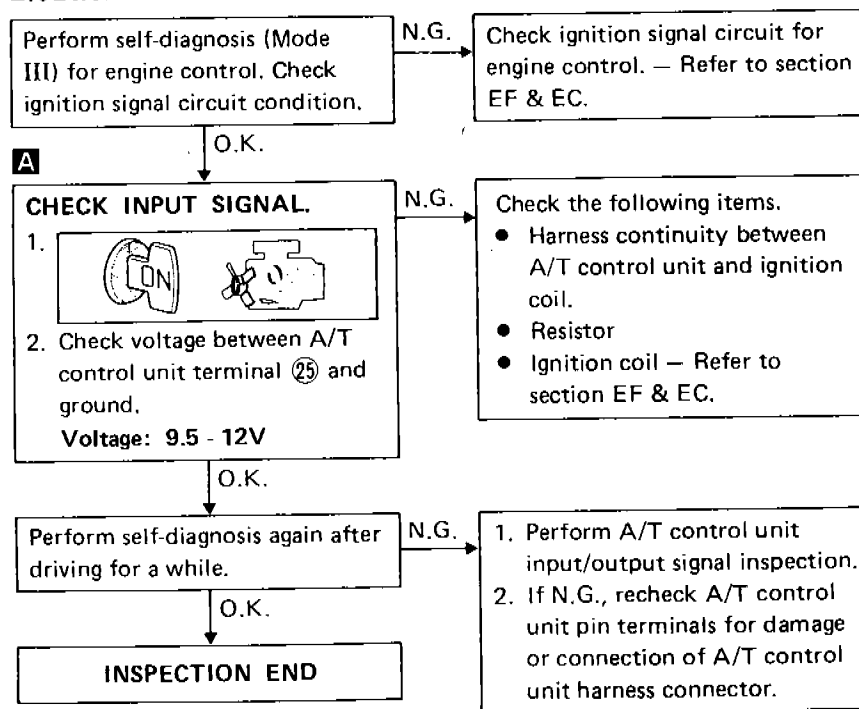
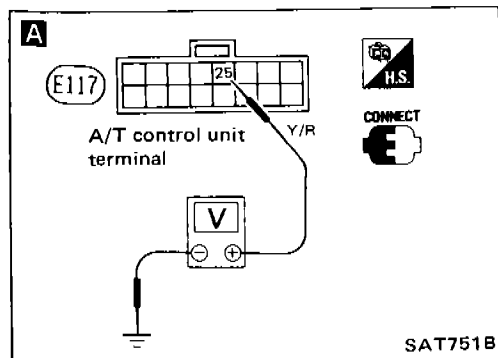

TROUBLE DIAGNOSES

Self-diagnosis (Cont'd)

LINE PRESSURE SOLENOID CIRCUIT CHECK

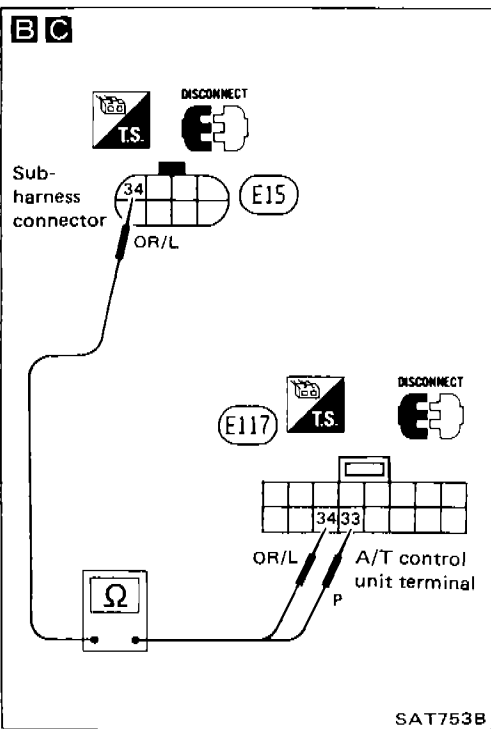
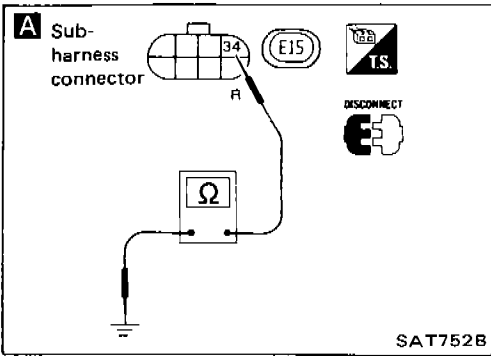
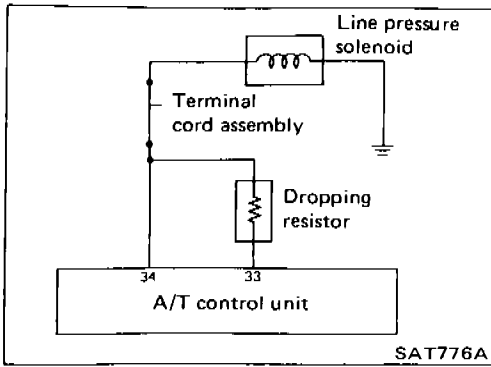

A

CHECK GROUND CIRCUIT.

1. 
2. Disconnect terminal cord assembly connector in engine compartment.
3. Check resistance between terminal ③④ and ground.
Resistance: 2.5 - 5Ω

N.G.

1. Remove control valve assembly. — Refer to "ON-VEHICLE SERVICE".
2. Check the following items.
 - Line pressure solenoid — Refer to "Electrical Components Inspection".
 - Harness continuity of terminal cord assembly

O.K.

B

CHECK POWER SOURCE CIRCUIT.

1. 
2. Disconnect A/T control unit 16-pin connector.
3. Check resistance between terminal ③④ and A/T control unit terminal ③③.
Resistance: 11.2 - 12.8Ω

N.G.

Check the following items.

- Dropping resistor — Refer to "Electrical Components Inspection".
- Harness continuity between A/T control unit ③③ and terminal cord assembly (Main harness)

O.K.

C

CHECK POWER SOURCE CIRCUIT

1. 
2. Check resistance between terminal ③④ and A/T control unit terminal ③④.
Resistance: Approximately 0Ω
3. Reinstall any part removed.

N.G.

Repair or replace harness between A/T control unit ③④ and terminal cord assembly.

O.K.

Perform self-diagnosis after driving for a while.

N.G.

1. Perform A/T control unit input/output signal inspection.
2. If N.G., recheck A/T control unit pin terminals for damage or connection of A/T control unit harness connector.

O.K.

INSPECTION END

TROUBLE DIAGNOSES

Self-diagnosis (Cont'd)

INHIBITOR, OVERDRIVE, KICKDOWN AND IDLE SWITCH CIRCUIT CHECKS

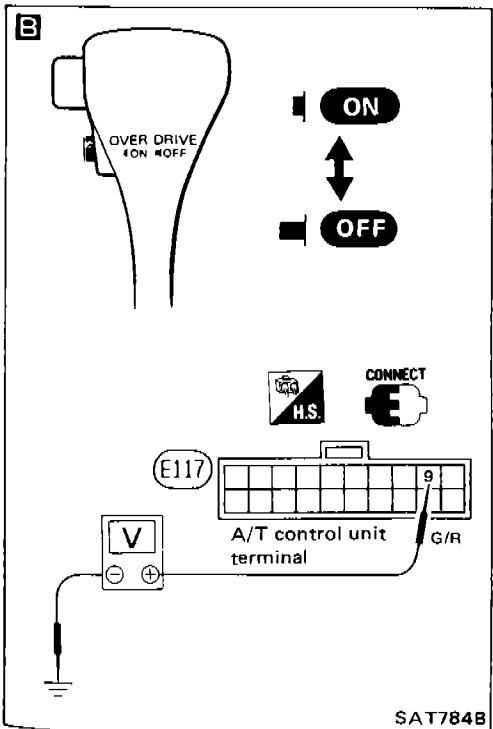
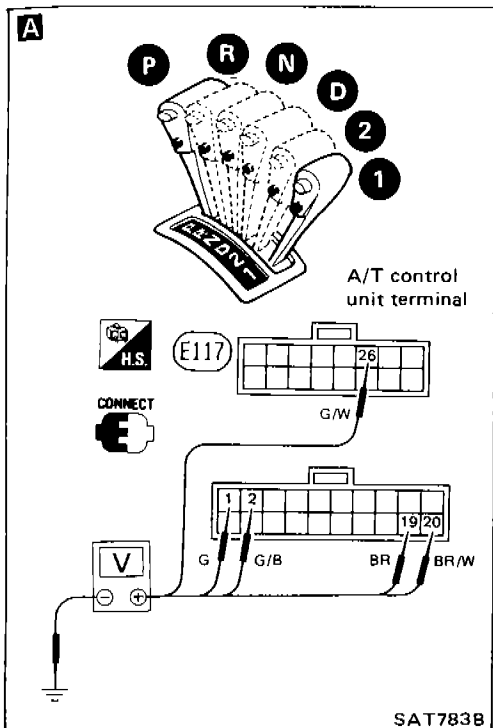
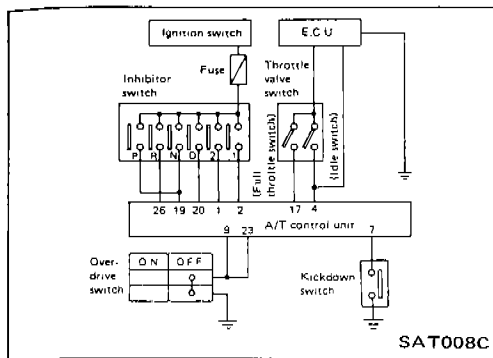

A

CHECK INHIBITOR SWITCH CIRCUIT.

-
- Check voltage between A/T control unit terminals ①, ②, ⑱, ⑳, ㉔ and ground while moving selector lever through each range.

Voltage:
B: Battery voltage
0: 0V

| Terminal No. | ⑱ | ㉔ | ⑳ | ① | ② |
|----------------|---|---|---|---|---|
| Lever position | | | | | |
| P, N | B | 0 | 0 | 0 | 0 |
| R | 0 | B | 0 | 0 | 0 |
| D | 0 | 0 | B | 0 | 0 |
| 2 | 0 | 0 | 0 | B | 0 |
| 1 | 0 | 0 | 0 | 0 | B |

N.G. → Check the following items.

- Inhibitor switch — Refer to "Electrical Components Inspection".
- Harness continuity between ignition switch and inhibitor switch (Main harness)
- Harness continuity between inhibitor switch and A/T control unit (Main harness)

O.K. ↓

B

CHECK OVERDRIVE SWITCH CIRCUIT.

-
- Check voltage between A/T control unit terminal ⑨ and ground when overdrive switch is in "ON" position and in "OFF" position.

| Switch position | Voltage |
|-----------------|-----------------|
| ON | Battery voltage |
| OFF | 1V or less |

N.G. → Check the following items.

- Overdrive switch — Refer to "Electrical Components Inspection".
- Harness continuity between A/T control unit and overdrive switch (Main harness)
- Harness continuity of ground circuit for overdrive switch (Main harness)

O.K. ↓

A

TROUBLE DIAGNOSES

Self-diagnosis (Cont'd)

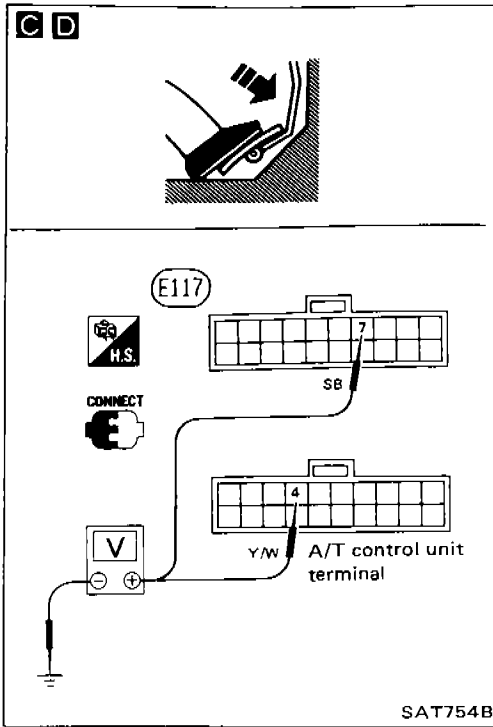

C

CHECK KICKDOWN SWITCH CIRCUIT.

-
- Check voltage between A/T control unit terminal ⑦ and ground while depressing accelerator pedal slowly. (after warming up engine)
Voltage:
 When releasing accelerator pedal: 3 - 8V
 When depressing accelerator pedal fully: 1V or less

N.G. → Check the following items.

- Kickdown switch
- Harness continuity between A/T control unit and kickdown switch (Main harness)
- Harness continuity of ground circuit for kickdown switch

D

CHECK IDLE SWITCH CIRCUIT.

- Check voltage between A/T control unit terminal ④ and ground in the same way as kickdown switch circuit.
Voltage:
 When releasing accelerator pedal: 8 - 15V
 When depressing accelerator pedal fully: 1V or less

N.G. → Perform self-diagnosis (Mode IV) for engine control. Check idle switch circuit.

O.K. → Check harness continuity between A/T control unit and idle switch. (Main harness)

N.G. → Check idle switch circuit for engine control. — Refer to section EF & EC.

O.K. → Perform self-diagnosis again after driving for a while.

- N.G. →
1. Perform A/T control unit input/output signal inspection.
 2. If N.G., recheck A/T control unit pin terminals for damage or connection of A/T control unit harness connector.

O.K. → **INSPECTION END**

TROUBLE DIAGNOSES

Diagnostic Procedure 1

SYMPTOM: O.D. OFF indicator lamp does not come on for about 2 seconds when turning ignition switch to "ON".

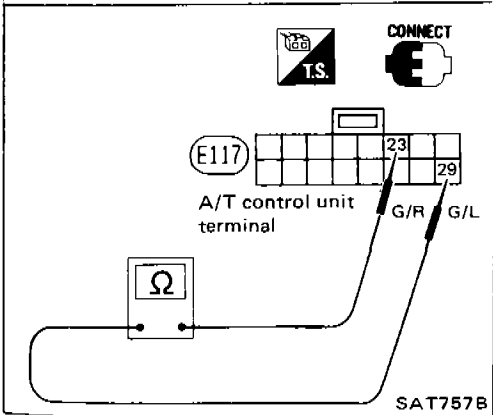
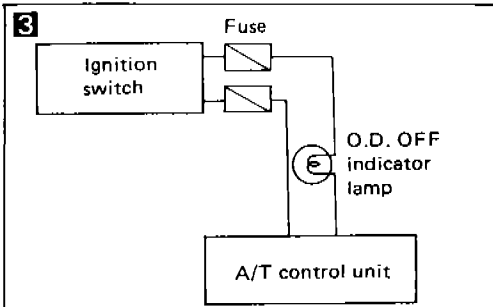
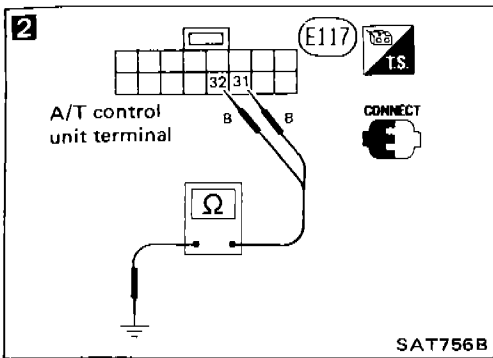
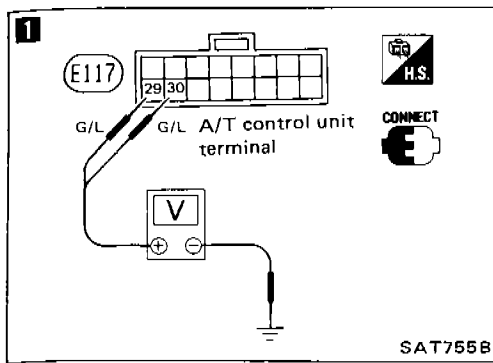

1

CHECK A/T CONTROL UNIT POWER SOURCE.

-
- Check voltage between A/T control unit terminals 29, 30 and ground. Battery voltage should exist.

N.G. → Check the following items.

- Harness continuity between ignition switch and A/T control unit (Main harness)
- Ignition switch and fuse — Refer to section EL.

O.K. ↓

2

CHECK A/T CONTROL UNIT GROUND CIRCUIT.

-
- Disconnect A/T control unit 16-pin connector.
- Check resistance between A/T control unit terminals 31, 32 and ground. Resistance: Approximately 0Ω

N.G. → Check harness continuity between A/T control unit and ground.

O.K. ↓

3

CHECK LAMP CIRCUIT.

-
- Disconnect A/T control unit 16-pin connector.
- Check resistance between A/T control unit terminals 23 and 29. Resistance: 50 - 100Ω
- Reinstall any part removed.

N.G. → Check the following items.

- O.D. OFF indicator lamp — Refer to section EL.
- Harness continuity between ignition switch and O.D. OFF indicator lamp (Main harness)
- Harness continuity between power shift indicator lamp and A/T control unit

O.K. ↓

Check again.

N.G. →

1. Perform A/T control unit input/output signal inspection.
2. If N.G., recheck A/T control unit pin terminals for damage or connection of A/T control unit harness connector.

O.K. ↓

INSPECTION END

TROUBLE DIAGNOSES

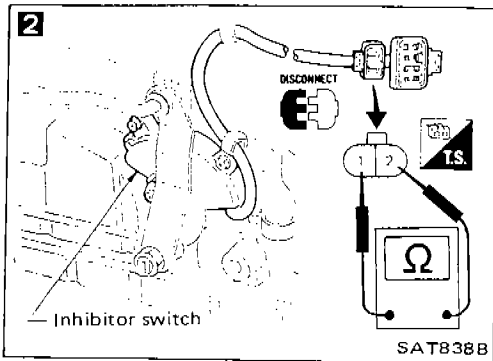
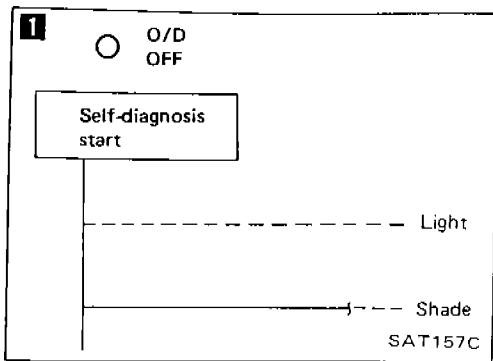

Diagnostic Procedure 2

SYMPTOM: Engine cannot be started with selector lever in "P" or "N" range or engine can be started with selector lever in "D", "2", "1" or "R" range.

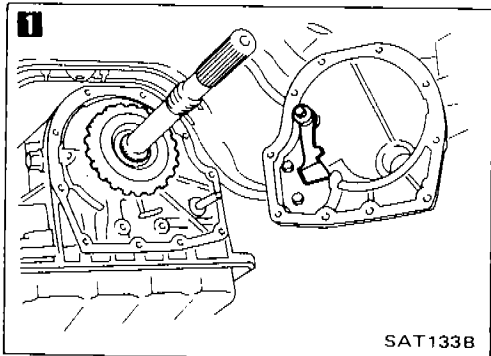
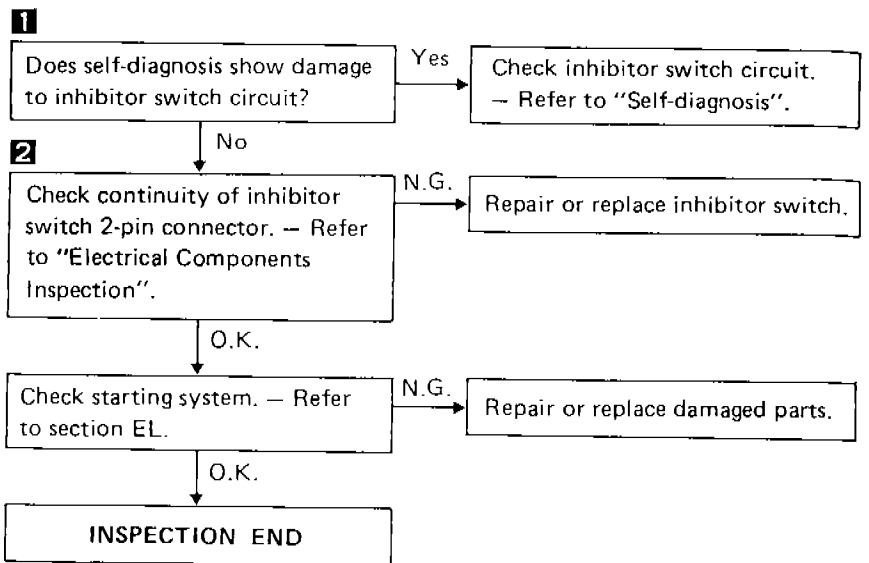

Diagnostic Procedure 3

SYMPTOM: Vehicle moves when it is pushed forward or backward with selector lever in "P" range.

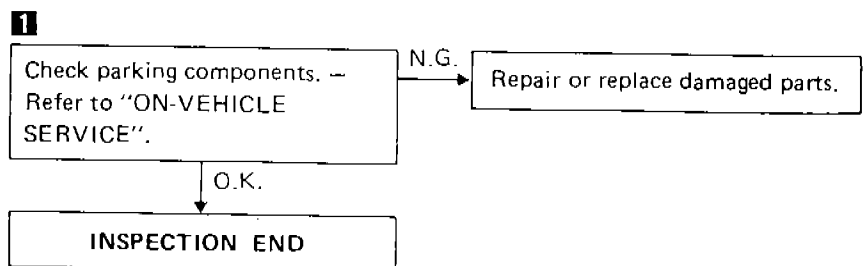

Diagnostic Procedure 4

SYMPTOM: Vehicle moves forward or backward when selecting "N" range.

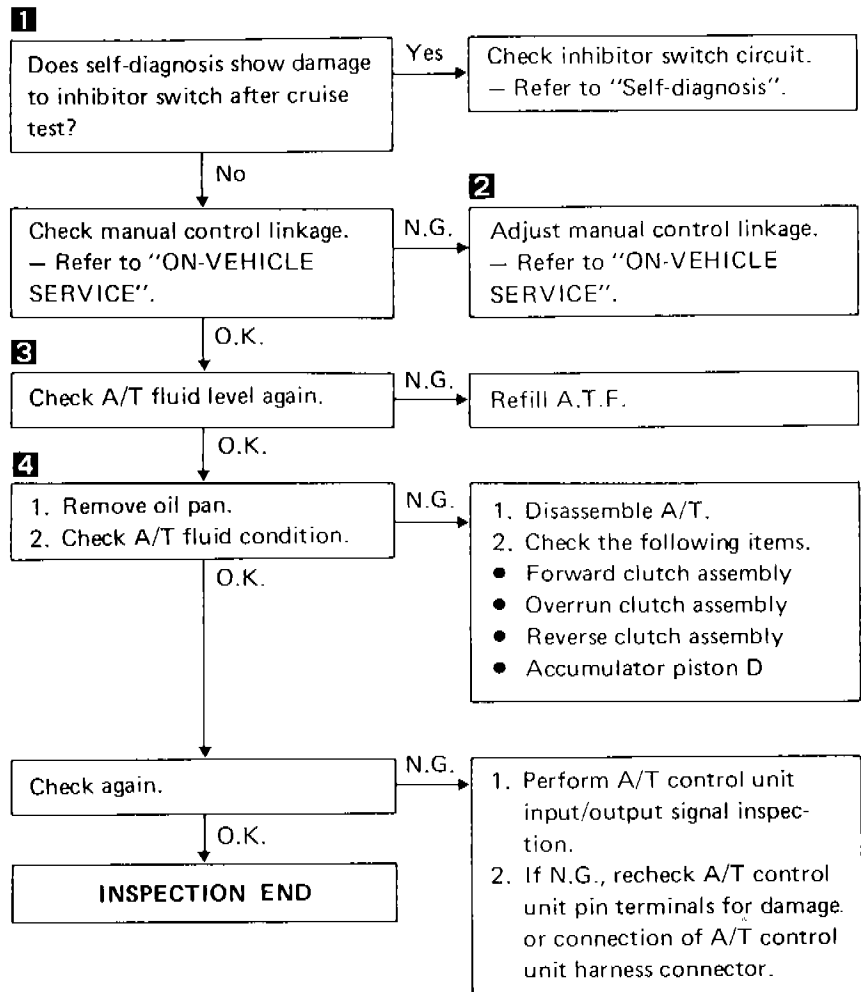
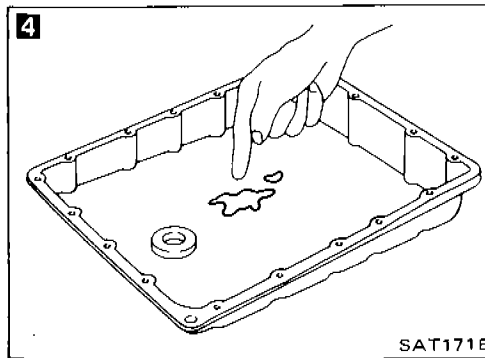
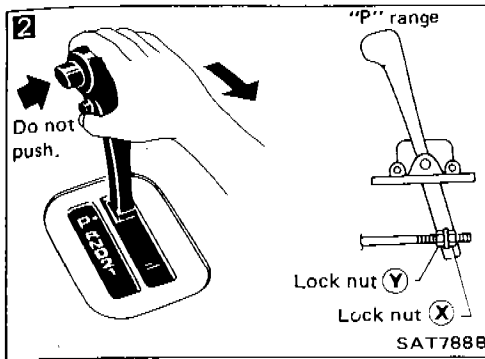
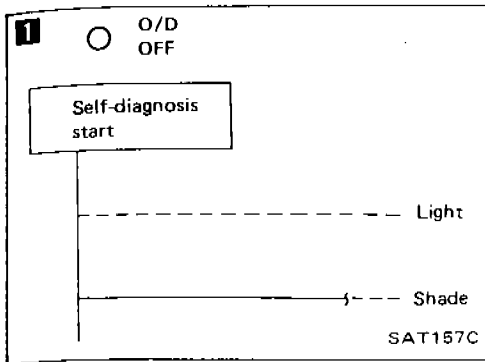

Diagnostic Procedure 5

SYMPTOM: There is large shock when changing from "N" to "R" range.

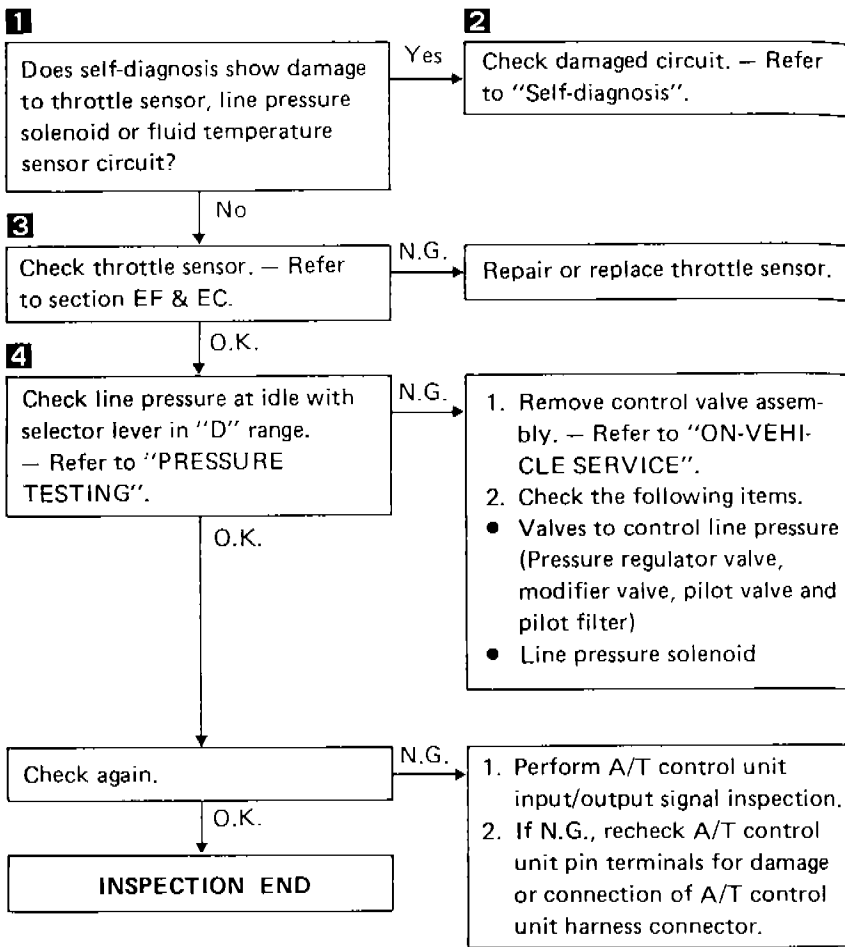
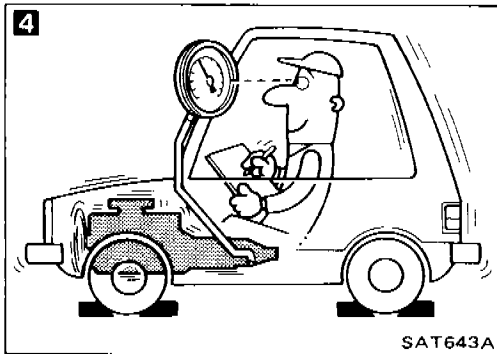
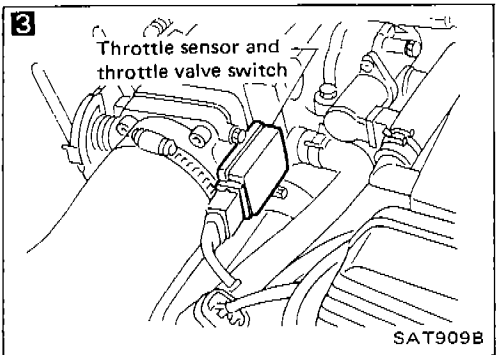
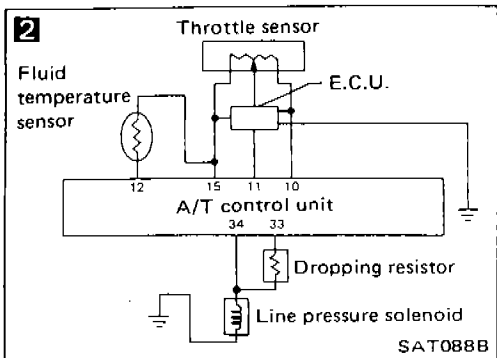
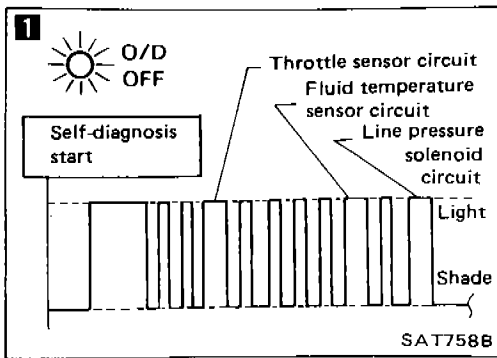

Diagnostic Procedure 6

SYMPTOM: Vehicle does not creep backward when selecting "R" range.

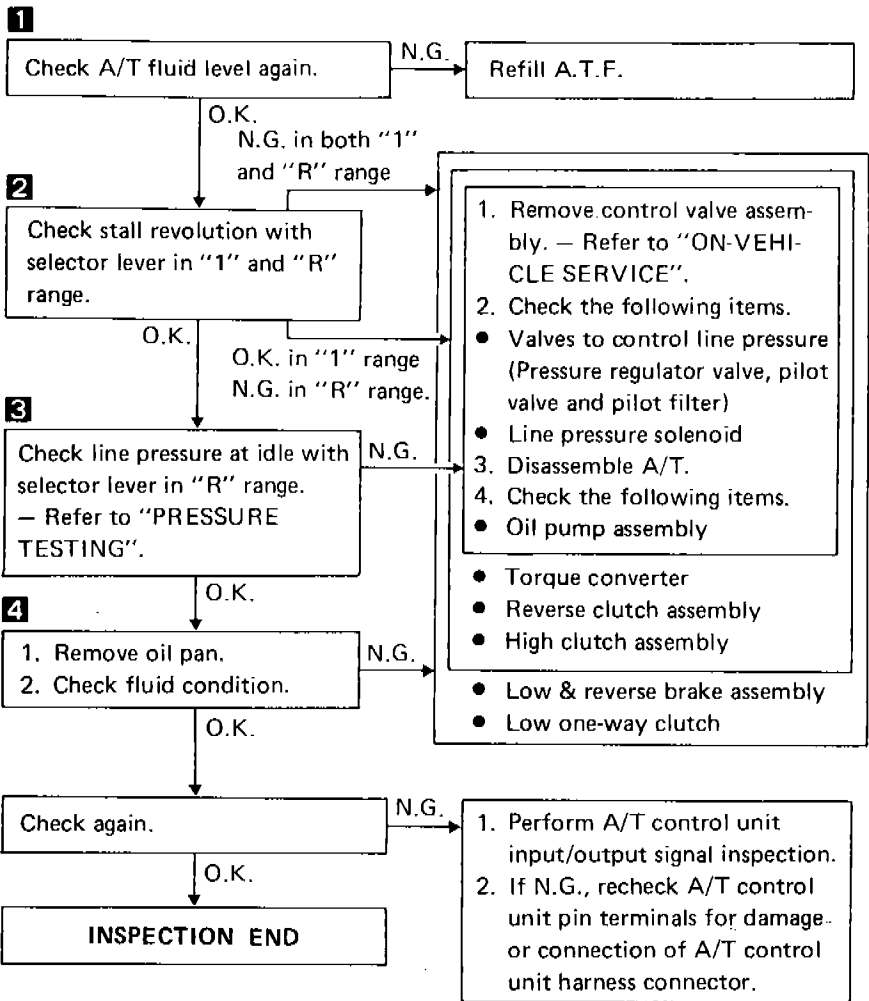
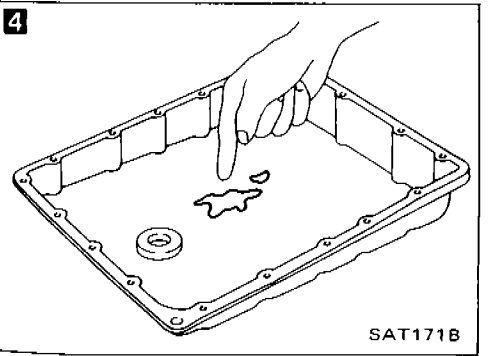
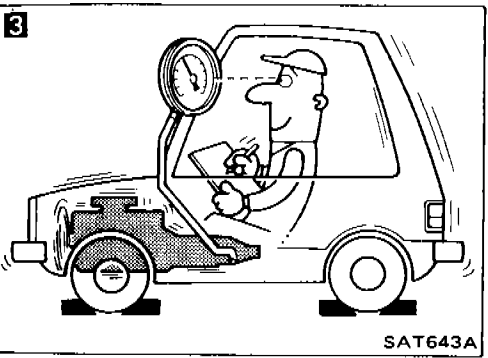
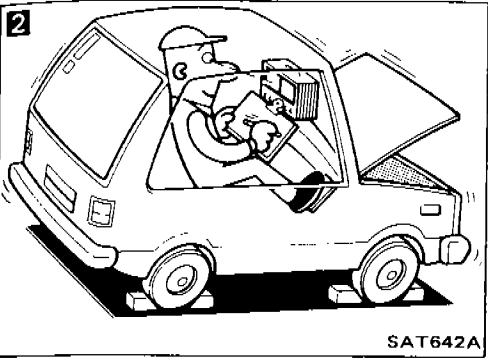

TROUBLE DIAGNOSES

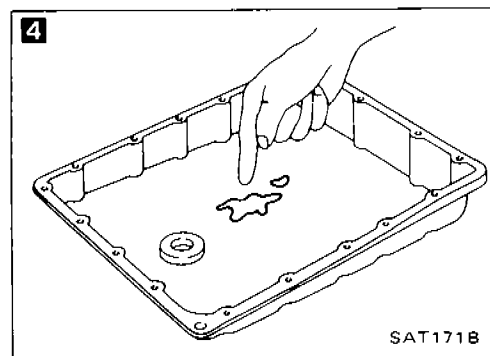
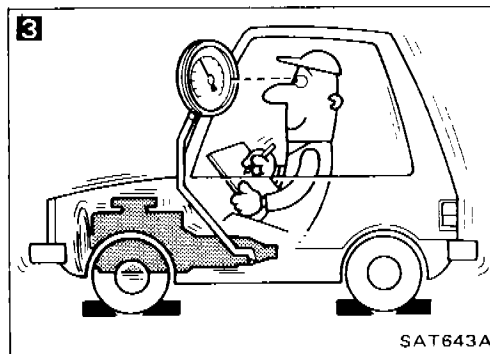
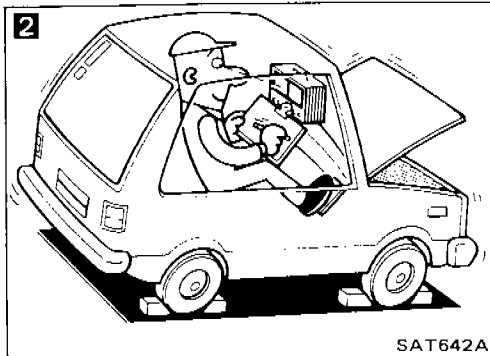
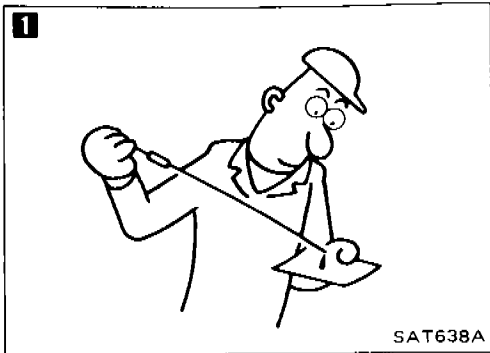

Diagnostic Procedure 7

SYMPTOM: Vehicle does not creep forward when selecting "D", "2" or "1" range.

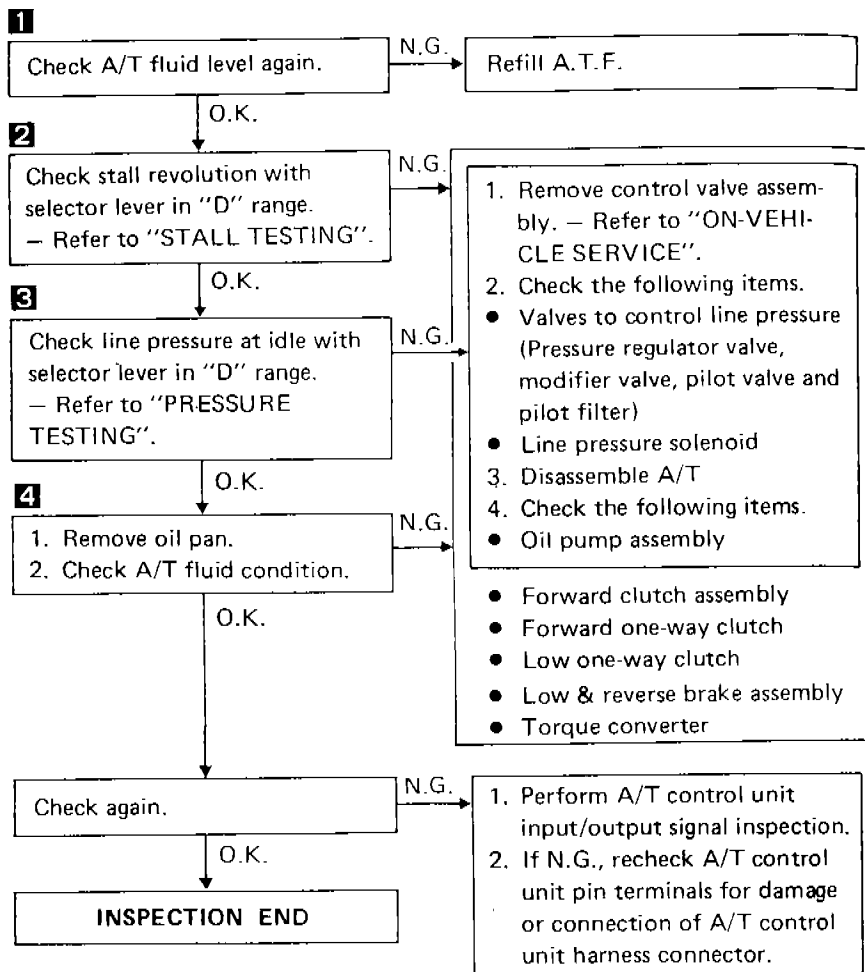

TROUBLE DIAGNOSES

Diagnostic Procedure 8

SYMPTOM: Vehicle cannot be started from D₁ on Cruise test — Part 1.

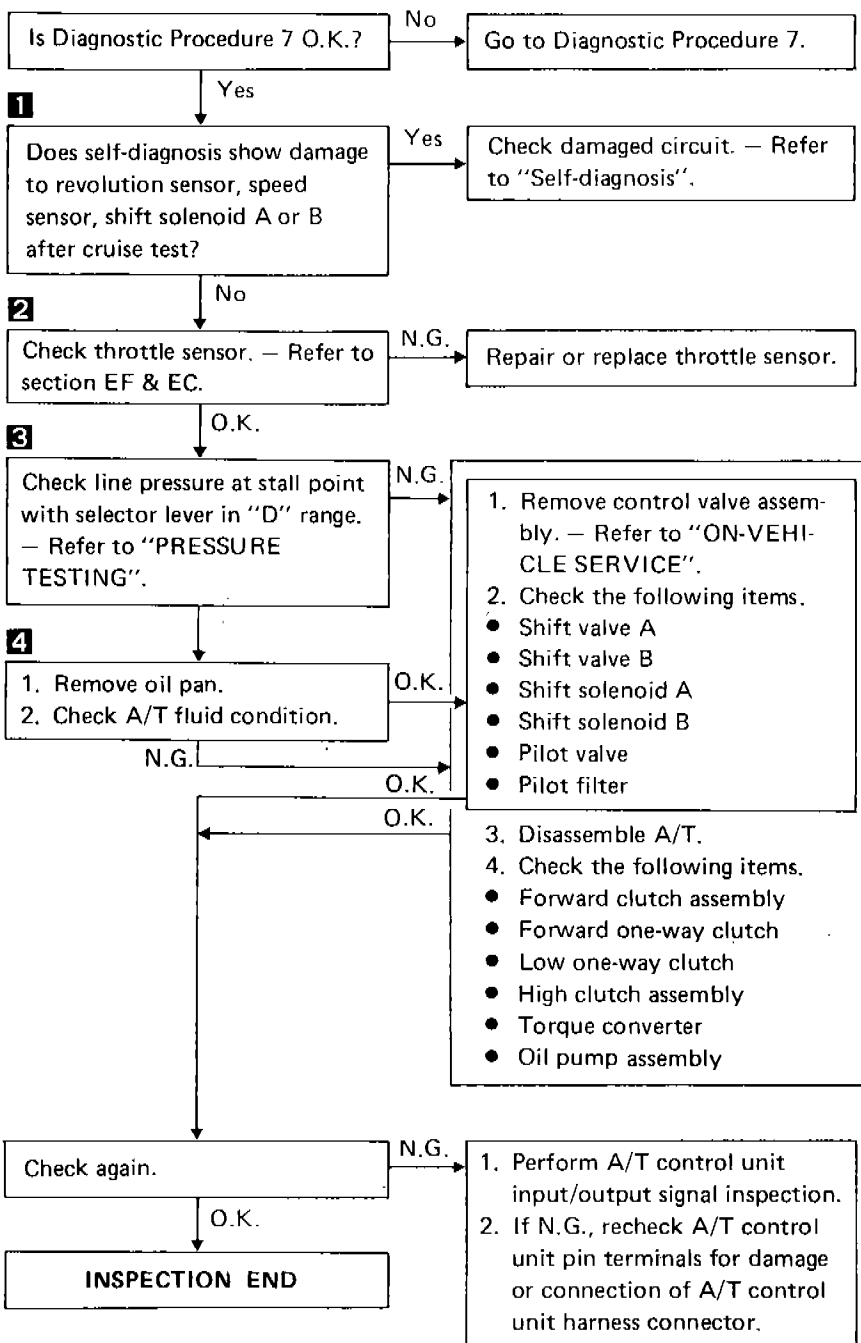
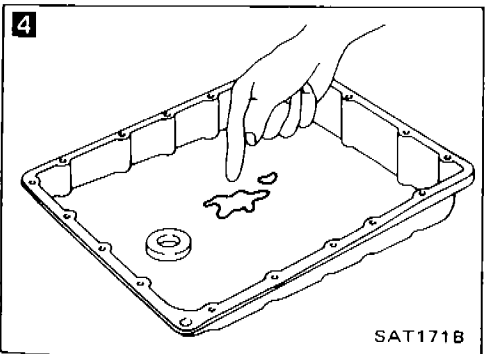
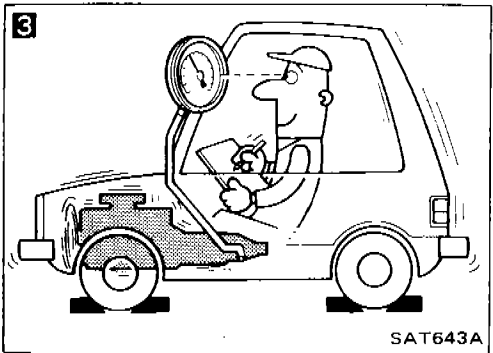
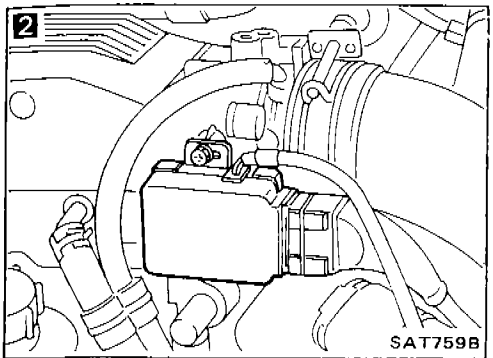
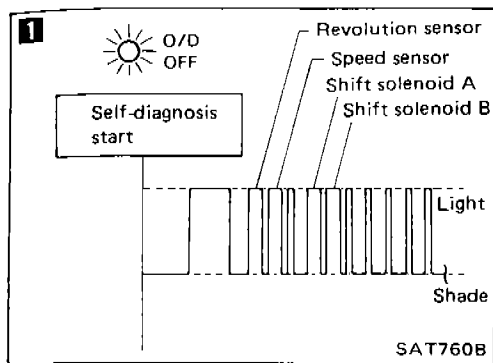

TROUBLE DIAGNOSES

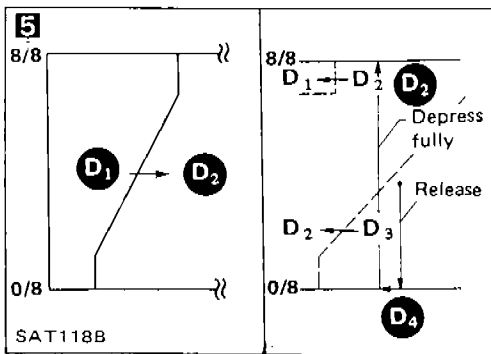
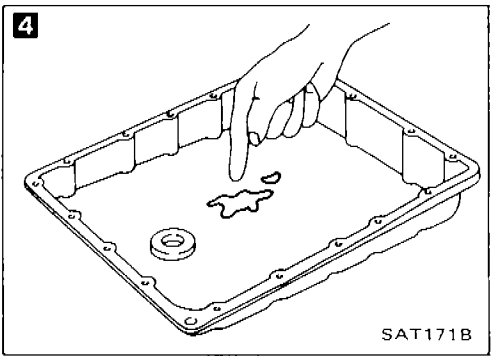
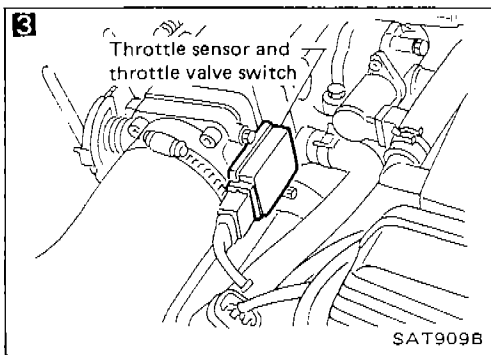
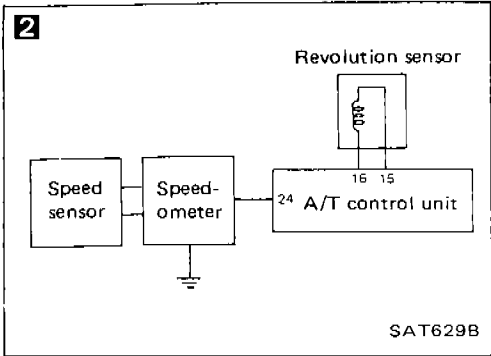
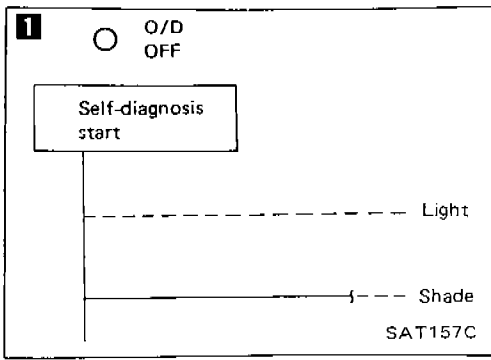

Diagnostic Procedure 9

SYMPTOM: A/T does not shift from D₁ to D₂ at the specified speed.
A/T does not shift from D₄ to D₂ when depressing accelerator pedal fully at the specified speed.

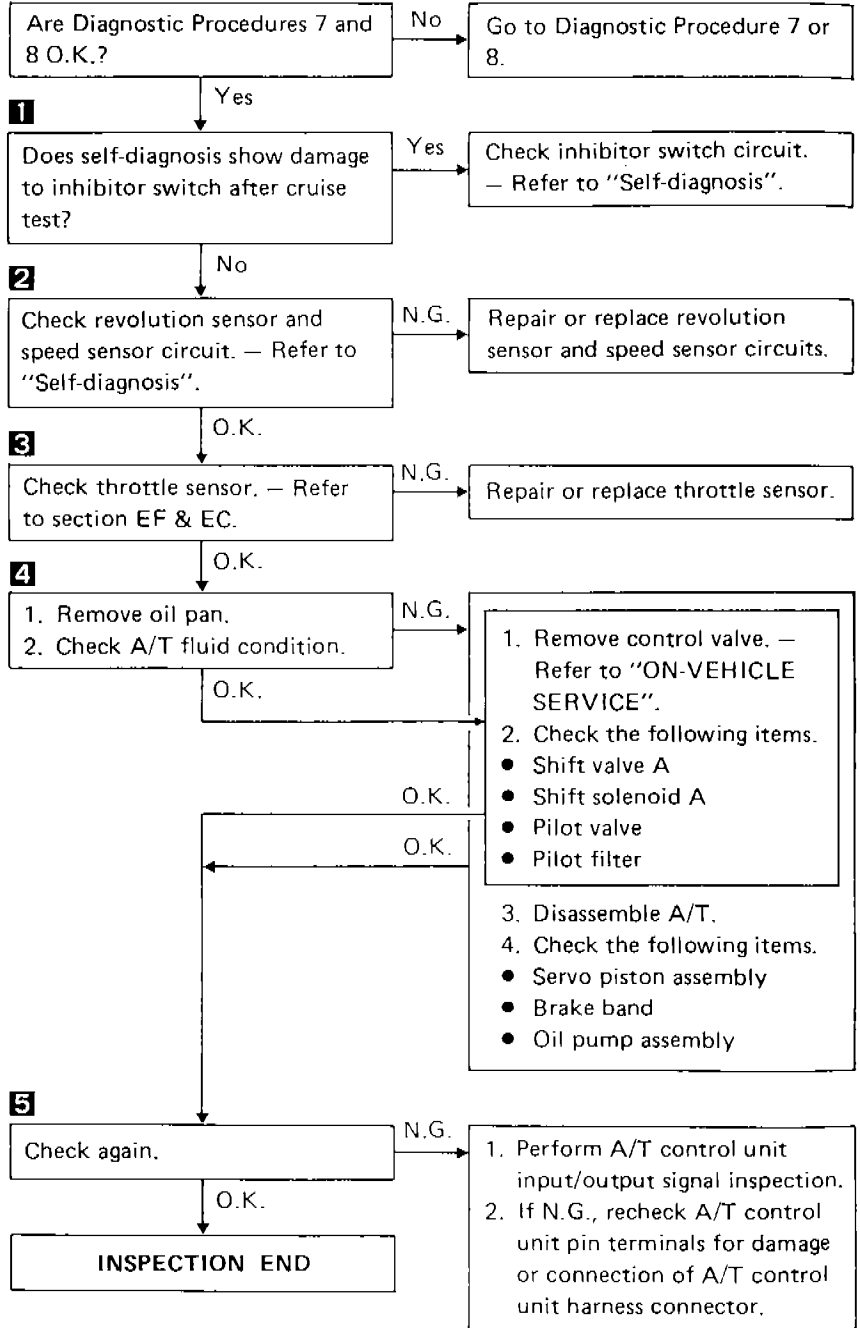

TROUBLE DIAGNOSES

Diagnostic Procedure 10

SYMPTOM: A/T does not shift from D₂ to D₃ at the specified speed.

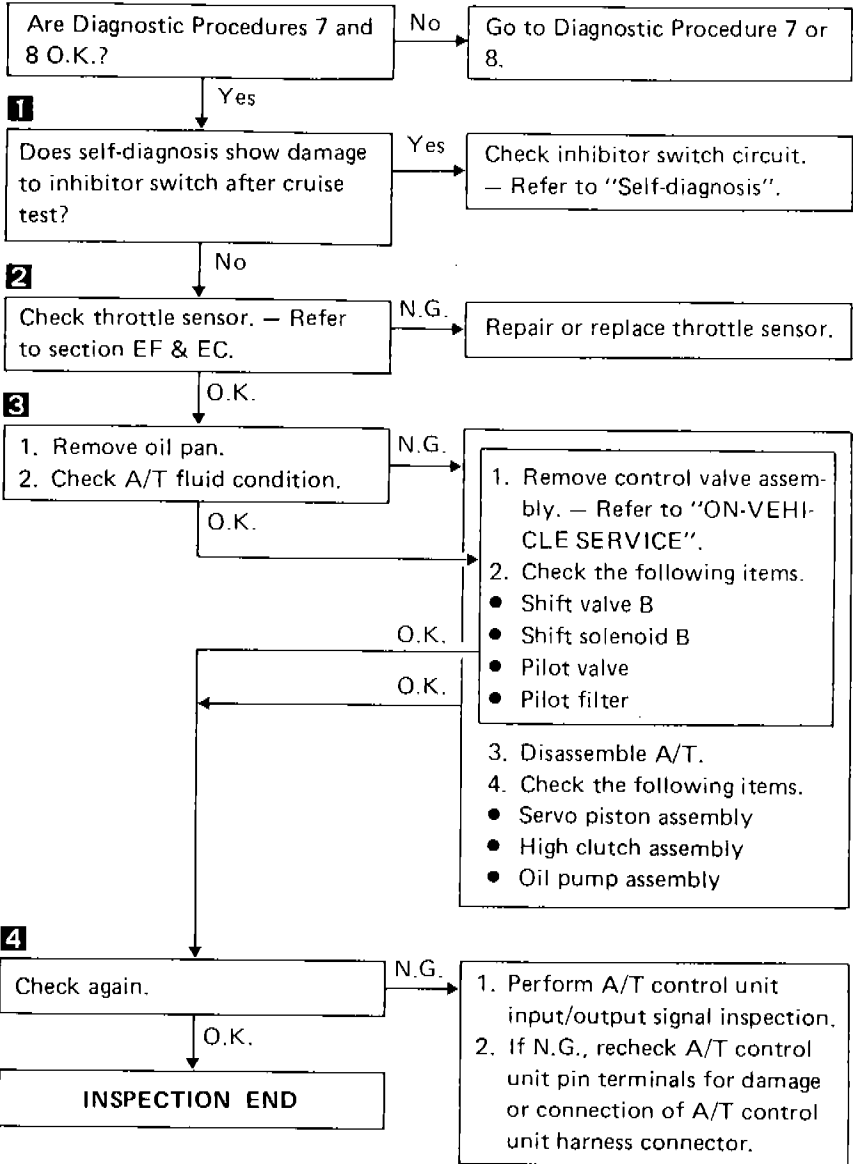
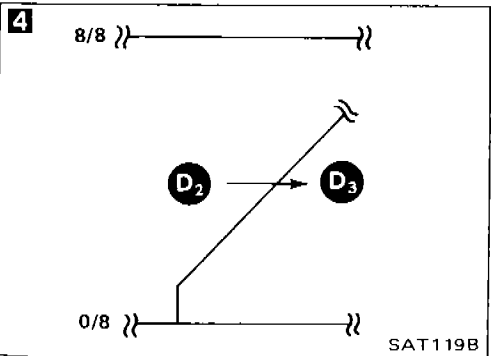
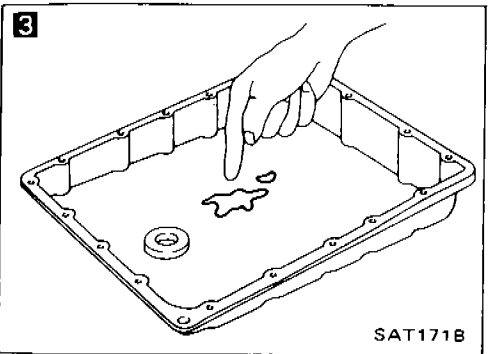
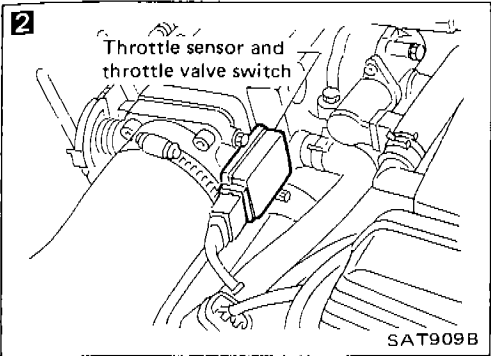
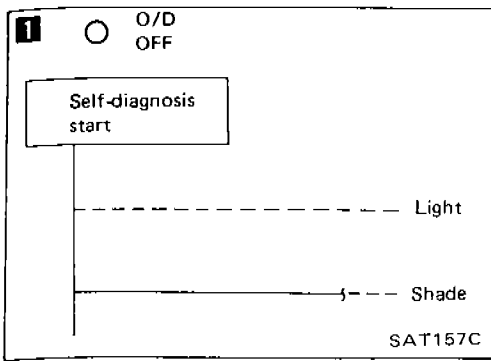

TROUBLE DIAGNOSES

Diagnostic Procedure 11

SYMPTOM: A/T does not shift from D₃ to D₄ at the specified speed.

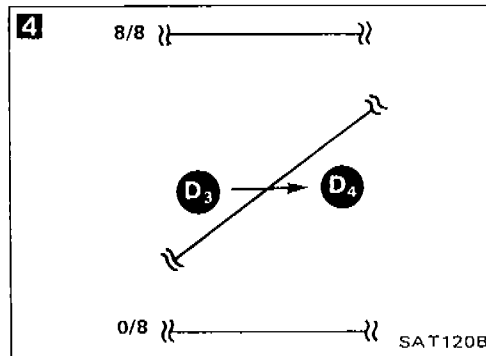
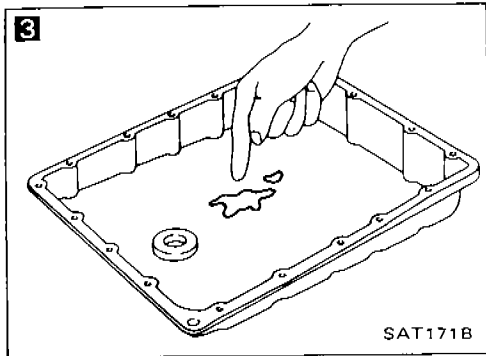
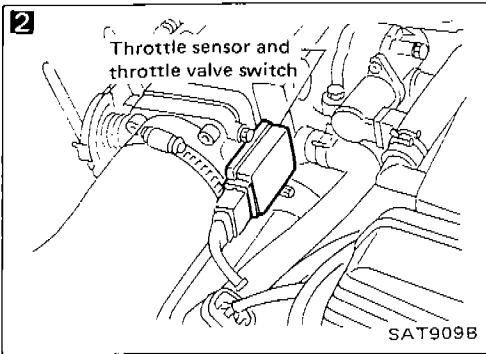
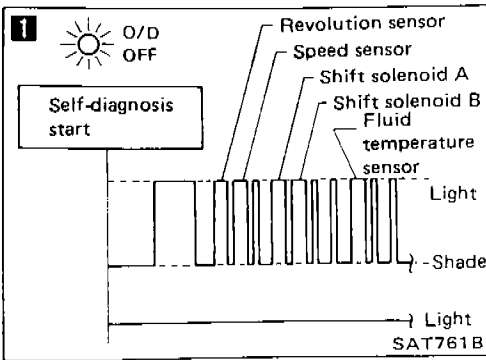

Are Diagnostic Procedures 7 and 8 O.K.?

No → Go to Diagnostic Procedure 7 or 8.

1 Does self-diagnosis show damage to inhibitor switch, overdrive switch, shift solenoid A, B, revolution sensor, speed sensor or fluid temperature sensor circuit after cruise test?

Yes → Check damaged circuit. — Refer to "Self-diagnosis".

2 Check throttle sensor. — Refer to section EF & EC.

N.G. → Repair or replace throttle sensor.

3 1. Remove oil pan.
2. Check A/T fluid condition.

N.G. → 1. Remove control valve assembly. — Refer to "ON-VEHICLE SERVICE".
2. Check the following items.
• Shift valve B
• Overrun clutch control valve
• Shift solenoid B
• Pilot valve
• Pilot filter

O.K. → 3. Disassemble A/T.
4. Check the following items.
• Servo piston assembly
• Brake band
• Torque converter
• Oil pump assembly

O.K. → 3. Disassemble A/T.
4. Check the following items.
• Servo piston assembly
• Brake band
• Torque converter
• Oil pump assembly

O.K. → 3. Disassemble A/T.
4. Check the following items.
• Servo piston assembly
• Brake band
• Torque converter
• Oil pump assembly

4 Check again.

N.G. → 1. Perform A/T control unit input/output signal inspection.
2. If N.G., recheck A/T control unit pin terminals for damage or connection of A/T control unit harness connector.

O.K. → INSPECTION END

Diagnostic Procedure 12

SYMPTOM: A/T does not perform lock-up at the specified speed.

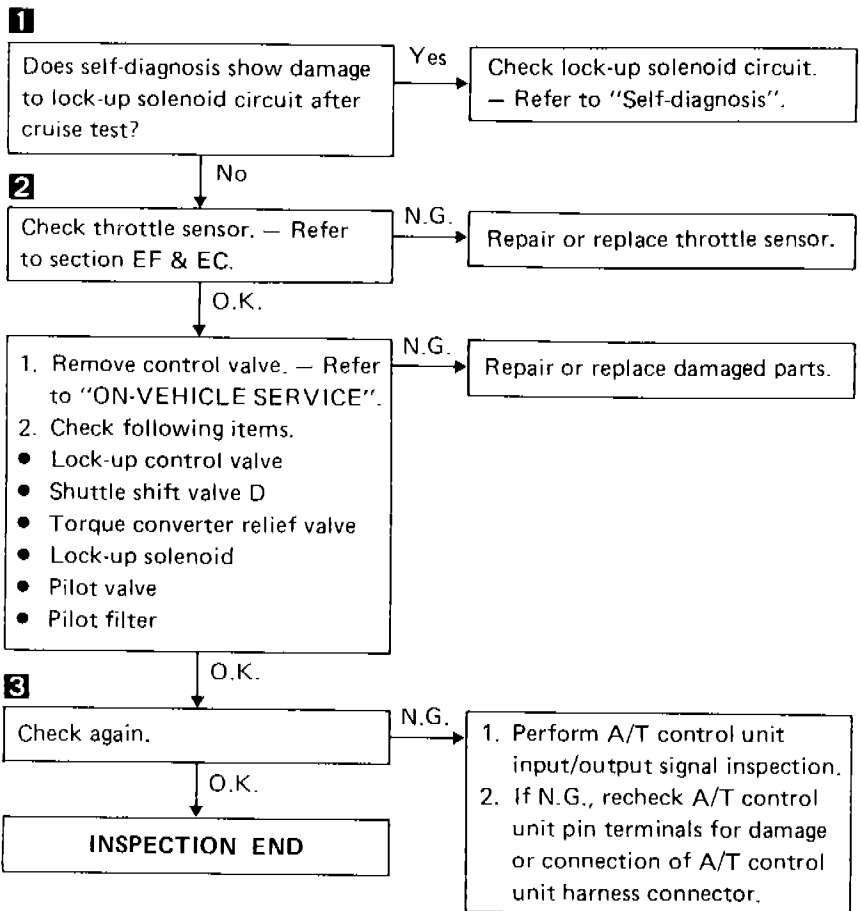
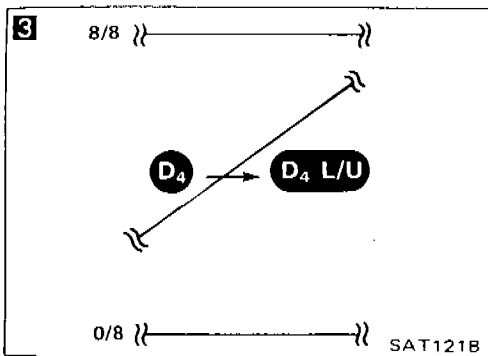
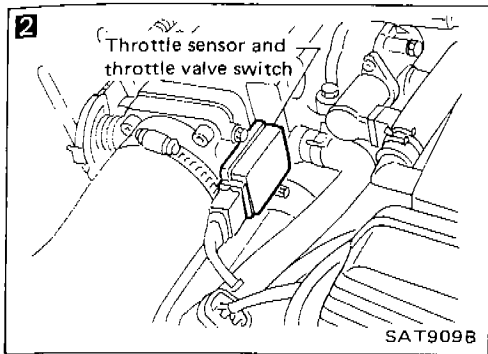
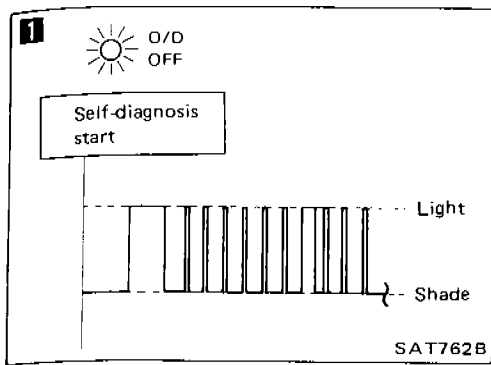

TROUBLE DIAGNOSES

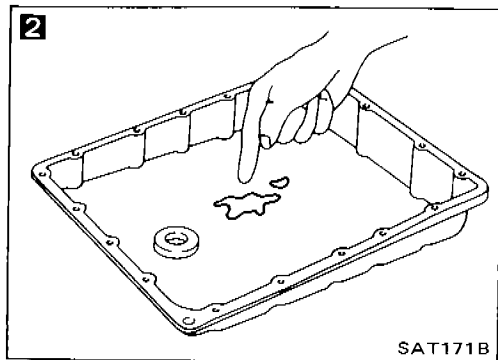
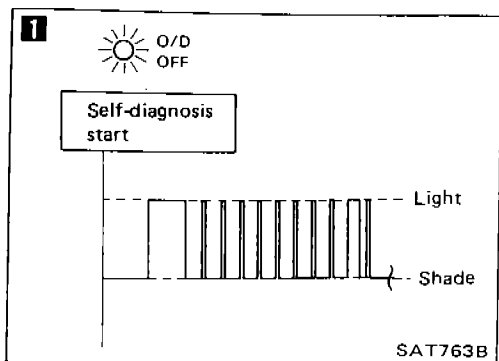

Diagnostic Procedure 13

SYMPTOM: A/T does not hold lock-up condition for more than 30 seconds.

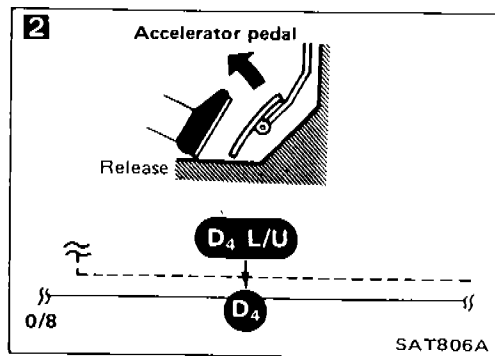
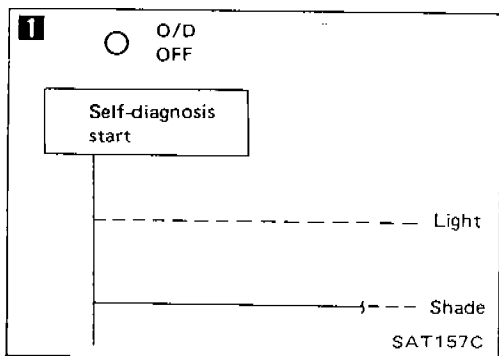
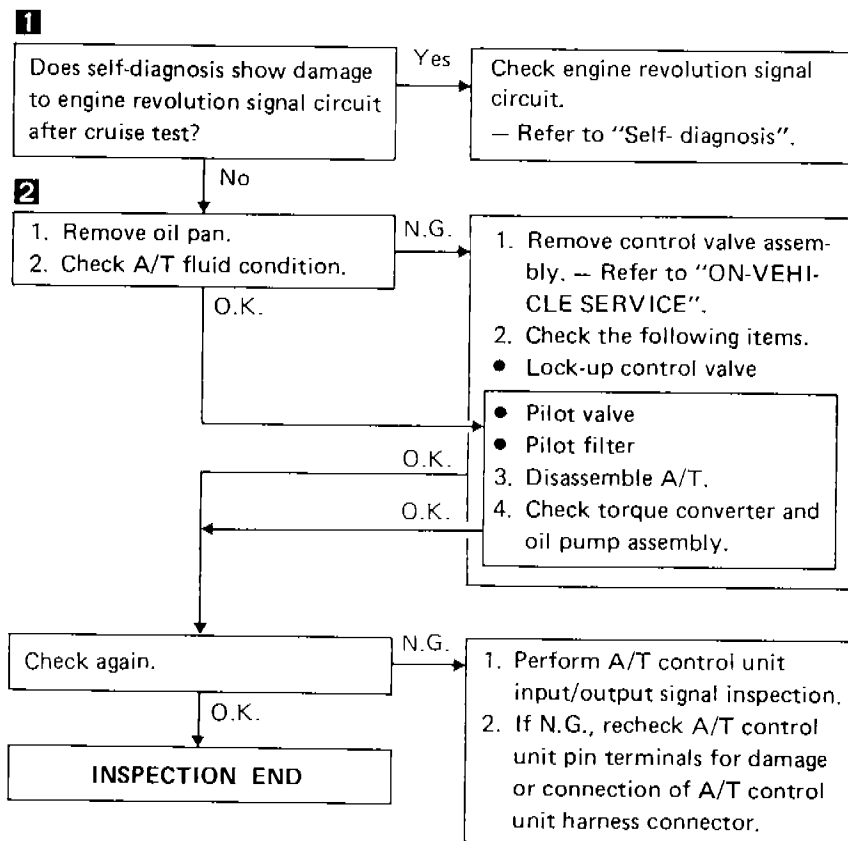

Diagnostic Procedure 14

SYMPTOM: Lock-up is not released when accelerator pedal is released.

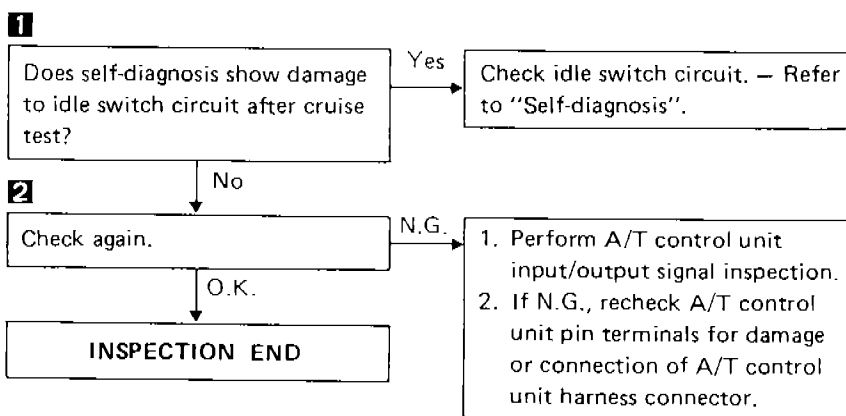

Diagnostic Procedure 15

SYMPTOM: Engine speed does not return to idle smoothly when A/T is shifted from D₄ to D₃ with accelerator pedal released.
 Vehicle does not decelerate by engine brake when changing overdrive switch to "OFF" position with accelerator pedal released.
 Vehicle does not decelerate by engine brake when changing selector lever from "D" to "2" range with accelerator pedal released.

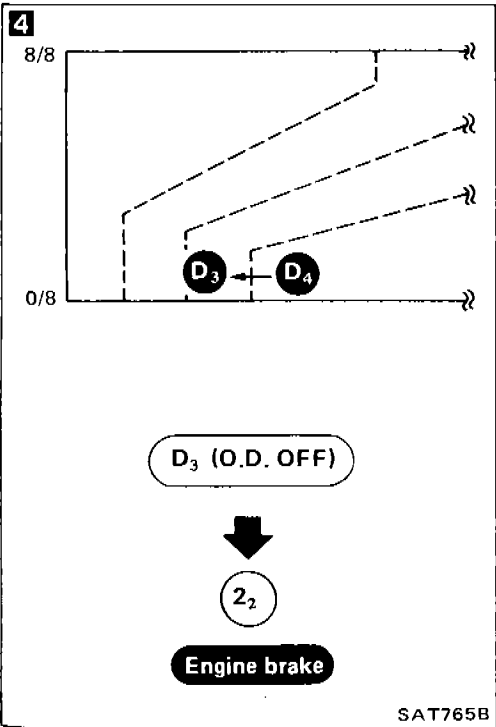
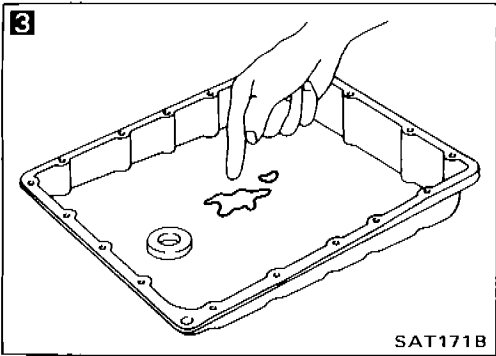
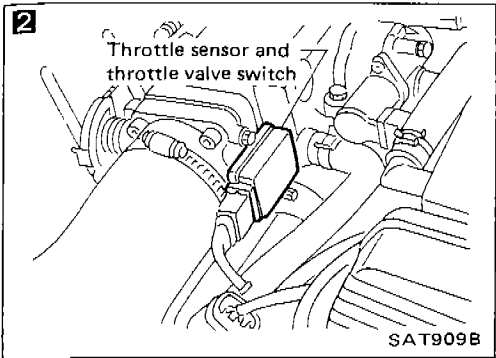
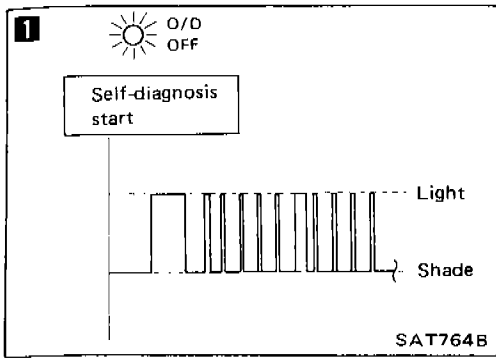

```

    graph TD
        Q1[1 Does self-diagnosis show damage to overrun clutch solenoid circuit after cruise test?] -- Yes --> A1[Check overrun clutch solenoid circuit. - Refer to "Self-diagnosis".]
        Q1 -- No --> Q2[2 Check throttle sensor. - Refer to section EF & EC.]
        Q2 -- N.G. --> A2[Repair or replace throttle sensor.]
        Q2 -- O.K. --> Q3[3 1. Remove oil pan.  
2. Check A/T fluid condition.]
        Q3 -- N.G. --> A3[1. Remove control valve assembly. - Refer to "ON-VEHICLE SERVICE".  
2. Check the following items:  
• Overrun clutch control valve  
• Overrun clutch reducing valve  
• Overrun clutch solenoid]
        Q3 -- O.K. --> A3
        A3 -- O.K. --> Q4[4 Check again.]
        A3 -- O.K. --> Q4
        Q4 -- N.G. --> A4[1. Perform A/T control unit input/output signal inspection.  
2. If N.G., recheck A/T control unit pin terminals for damage or connection of A/T control unit harness connector.]
        Q4 -- O.K. --> END[INSPECTION END]
    
```

TROUBLE DIAGNOSES

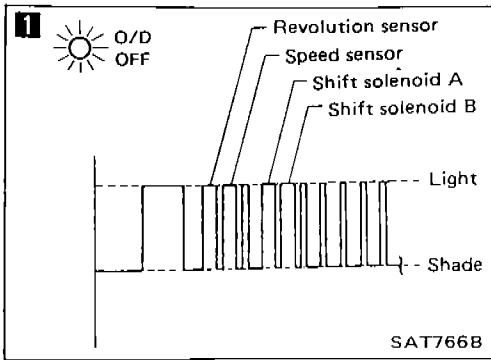

Diagnostic Procedure 16

SYMPTOM: Vehicle does not start from D₁ on Cruise test — Part 2.

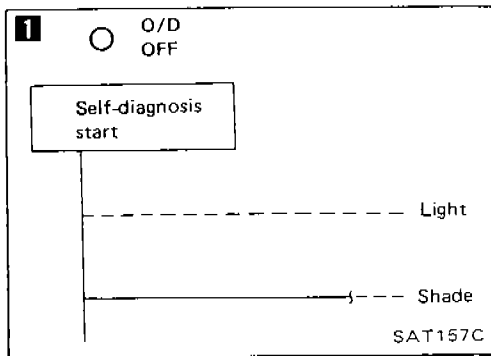
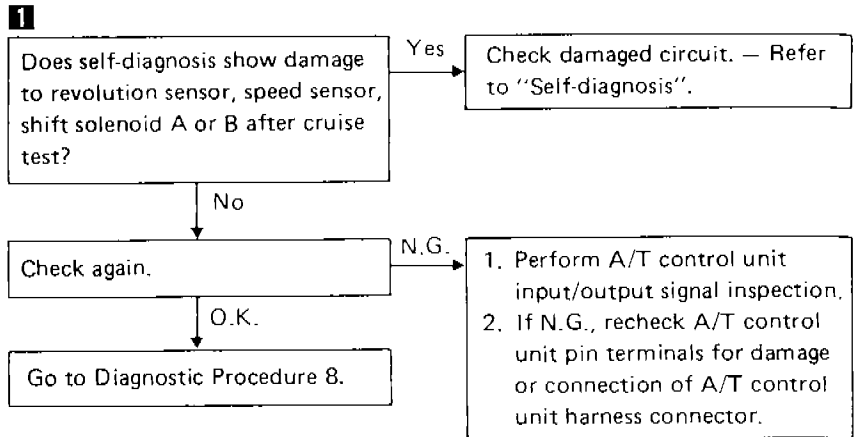

Diagnostic Procedure 17

SYMPTOM: A/T does not shift from D₄ to D₃ when changing overdrive switch to "OFF" position.

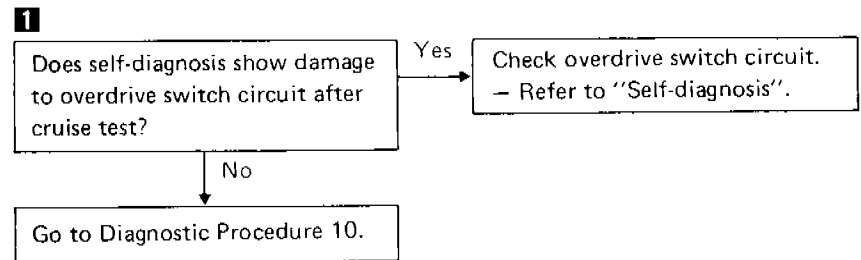

TROUBLE DIAGNOSES

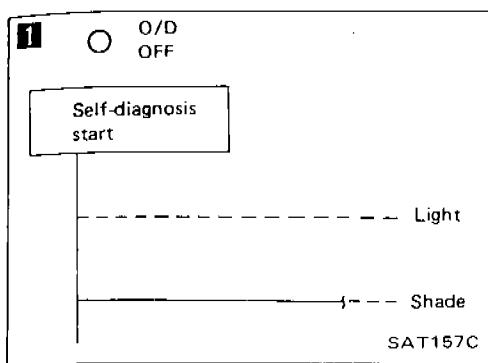

Diagnostic Procedure 18

SYMPTOM: A/T does not shift from D_3 to 2_2 when changing selector lever from "D" to "2" range.

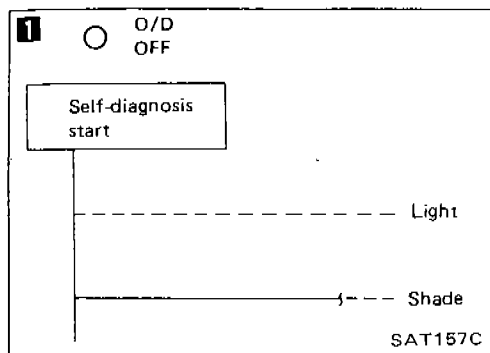
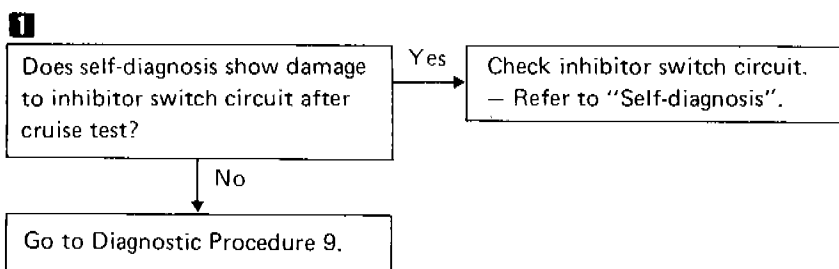

Diagnostic Procedure 19

SYMPTOM: A/T does not shift from 2_2 to 1_1 when changing selector lever from "2" to "1" range.

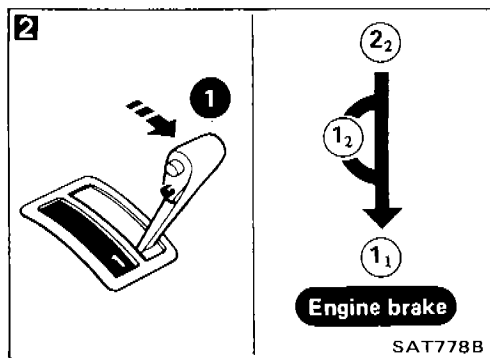
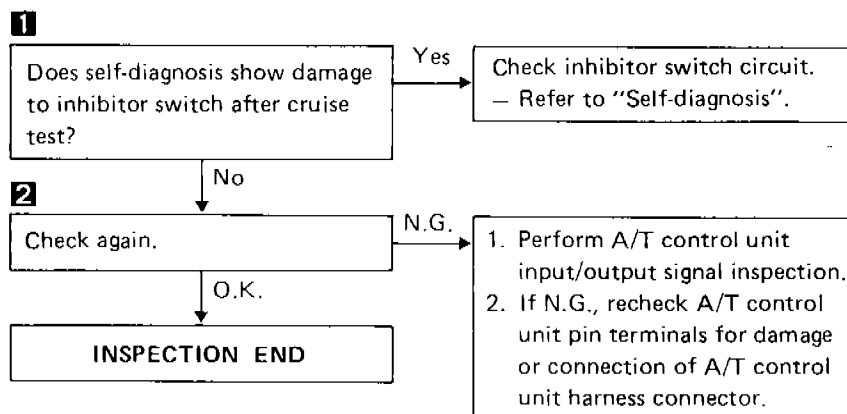

Diagnostic Procedure 20

SYMPTOM: Vehicle does not decelerate by engine brake when shifting from 2_2 (1_2) to 1_1 .

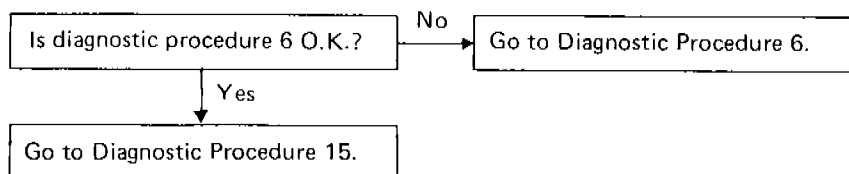

TROUBLE DIAGNOSES

Electrical Components Inspection

INSPECTION OF A/T CONTROL UNIT

- Measure voltage between each terminal and terminal ③① or ③② by following "A/T CONTROL UNIT INSPECTION TABLE".

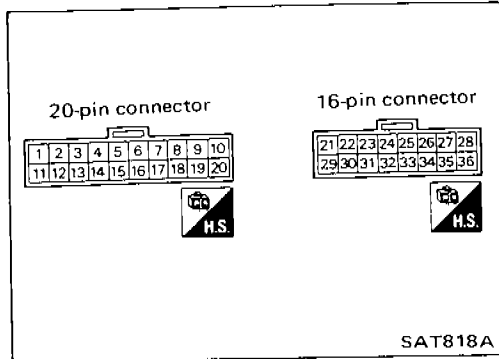
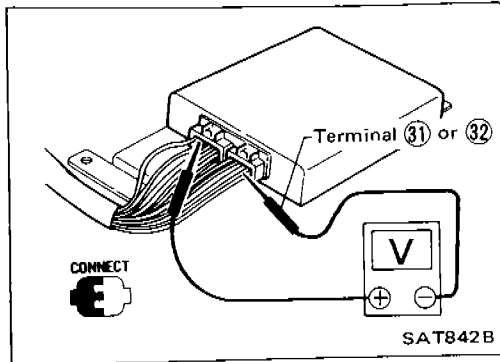





- Pin connector terminal layout.

A/T CONTROL UNIT INSPECTION TABLE
(Data are reference values.)

| Terminal No. | Item | Condition | Judgement standard |
|--------------|----------------------------------------|------------------------------------------------------------|--------------------|
| 1 | Inhibitor "2" range switch | When setting selector lever to "D" range. | Battery voltage |
| | | When setting selector lever to other ranges. | 1V or less |
| 2 | Inhibitor "1" range switch | When setting selector lever to "1" range. | Battery voltage |
| | | When setting selector lever to other ranges. | 1V or less |
| 3 | — | — | — |
| 4 | Idle switch (in throttle valve switch) | When releasing accelerator pedal after warming up engine. | 8 - 15V |
| | | When depressing accelerator pedal after warming up engine. | 1V or less |
| 5 | — | — | — |
| 6 | — | — | — |

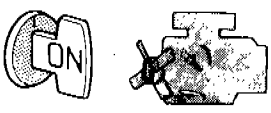

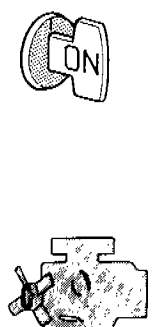



TROUBLE DIAGNOSES

Electrical Components Inspection (Cont'd)

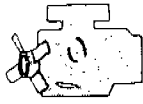
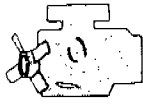
| Terminal No. | Item | Condition | Judgement standard | |
|--------------|-----------------------------------------|-------------------------------------------------------------------------------------|-------------------------------------------------------------------|--------------------------------------------------------------------|
| 7 | Kickdown switch |  | When releasing accelerator pedal after warming up engine. | 3 - 8V |
| | | | When depressing accelerator pedal fully after warming up engine. | 1V or less |
| 8 | — | — | — | |
| 9 | Overdrive switch |  | When setting overdrive switch in "ON" position. | Battery voltage |
| | | | When setting overdrive switch in "OFF" position. | 1V or less |
| 10 | Throttle sensor (Power source) | — | 4.5 - 5.5V | |
| 11 | Throttle sensor |  | When depressing accelerator pedal slowly after warming up engine. | Fully-closed throttle: 0.2 - 0.6V |
| | | | Voltage rises gradually in response to throttle opening angle. | Fully-open throttle: 2.9 - 3.9V |
| 12 | Fluid temperature sensor |  | When A.T.F. temperature is 20°C (68°F). | 1.56V |
| | | | When A.T.F. temperature is 80°C (176°F). | 0.45V |
| 13 | — | — | — | |
| 14 | — | — | — | |
| 15 | Throttle sensor (Ground) | — | — | |
| 16 | Revolution sensor (Measure in AC range) |  | When vehicle cruises at 30 km/h (19 MPH). | (1V or more Voltage rises gradually in response to vehicle speed.) |
| | | | When vehicle parks. | 0V |



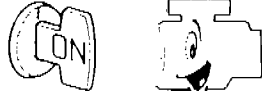



TROUBLE DIAGNOSES

Electrical Components Inspection (Cont'd)

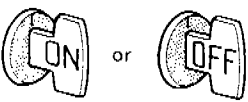
| Terminal No. | Item | Condition | Judgement standard | |
|--------------|------------------------------------|-------------------------------------------------------------------------------------|-------------------------------------------------------------------------------|-------------------|
| 17 | Full throttle switch |  | When depressing accelerator pedal more than half-way after warming up engine. | 8 - 15V |
| | | | When releasing accelerator pedal after warming up engine. | 1V or less |
| 18 | — | — | — | |
| 19 | Inhibitor "N" and "P" range switch |  | When setting selector lever to "N" or "P" range. | Battery voltage |
| | | | When setting selector lever to other ranges. | 1V or less |
| 20 | Inhibitor "D" range switch |  | When setting selector lever to "2" range. | Battery voltage |
| | | | When setting selector lever to other ranges. | 1V or less |
| 21 | Overrun clutch solenoid |  | When overrun clutch solenoid operates. | Battery voltage |
| | | | When overrun clutch solenoid does not operate. | 1V or less |
| 22 | Lock-up solenoid |  | When A/T performs lock-up. | 8 - 15V |
| | | | When A/T does not perform lock-up. | 1V or less |
| 23 | O.D. OFF indicator lamp |  | When setting overdrive switch to "ON" position. | Battery voltage |
| | | | When setting overdrive switch to "OFF" position. | 1V or less |
| 24 | Speed sensor |  | When moving vehicle at 2 to 3 km/h (1 to 2 MPH) for 1 m (3 ft) or more. | Vary from 0 to 5V |
| 25 | Engine revolution signal |  | When engine runs at idle speed. | 9.5 - 12V |
| | | | When engine runs at 2,500 rpm. | Approximately 10V |
| 26 | Inhibitor "R" range switch |  | When setting selector lever to "R" range. | Battery voltage |
| | | | When setting selector lever to other ranges. | 1V or less |
| 27 | — | — | — | |

TROUBLE DIAGNOSES

Electrical Components Inspection (Cont'd)

| Terminal No. | Item | Condition | Judgement standard | |
|--------------|-------------------------------------------------|---------------------------------------------------------------------------------------------------------------------------------------------|---------------------------------------------------------------------------------------------------|-----------------|
| 28 | Power source (Back-up) |  When turning ignition switch to "OFF". | Battery voltage | |
| | | When turning ignition switch to "ON". | Battery voltage | |
| 29 30 | Power source |  When turning ignition switch to "ON". | Battery voltage | |
| | | When turning ignition switch to "OFF". | 1V or less | |
| 31 32 | Ground | — | — | |
| 33 | Line pressure solenoid (with dropping resistor) |  When releasing accelerator pedal after warming up engine. | 5 - 14V | |
| | | When depressing accelerator pedal fully after warming up engine. | 0.5V or less | |
| 34 | Line pressure solenoid |  When releasing accelerator pedal after warming up engine. | 1.5 - 2.5V | |
| | | When depressing accelerator pedal fully after warming up engine. | 0.5V or less | |
| 35 | Shift solenoid A |  | When shift solenoid A operates. (When driving in "D ₁ " or "D ₄ ".) | Battery voltage |
| | | | When shift solenoid A does not operate. (When driving in "D ₂ " or "D ₃ ".) | 1V or less |
| 36 | Shift solenoid B |  | When shift solenoid B operates. (When driving in "D ₁ " or "D ₂ ".) | Battery voltage |
| | | | When shift solenoid B does not operate. (When driving in "D ₃ " or "D ₄ ".) | 1V or less |

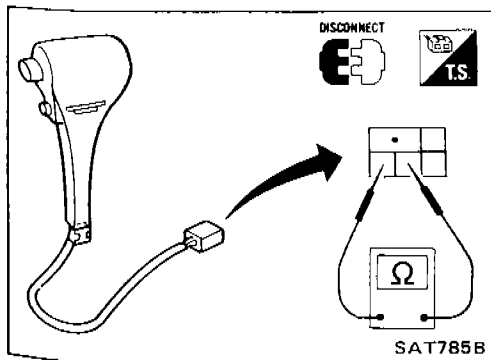

OVERDRIVE SWITCH

- Check continuity between two terminals.

| O.D. switch position | Continuity |
|----------------------|------------|
| ON | No |
| OFF | Yes |

TROUBLE DIAGNOSES

Electrical Components Inspection (Cont'd) INHIBITOR SWITCH

1. Check continuity between terminals ① and ② and between terminals ③ and ④, ⑤, ⑥, ⑦, ⑧, ⑨ while moving selector lever through each range.

| Terminal No. / Lever position | ① | ② | ③ | ④ | ⑤ | ⑥ | ⑦ | ⑧ | ⑨ |
|-------------------------------|-----|---|-----|-----|-----|-----|-----|-----|---|
| P | ○—○ | | ○—○ | | | | | | |
| R | | | ○—○ | ○—○ | | | | | |
| N | ○—○ | | ○—○ | ○—○ | ○—○ | | | | |
| D | | | ○—○ | ○—○ | ○—○ | ○—○ | | | |
| 2 | | | ○—○ | ○—○ | ○—○ | ○—○ | ○—○ | | |
| 1 | | | ○—○ | ○—○ | ○—○ | ○—○ | ○—○ | ○—○ | |

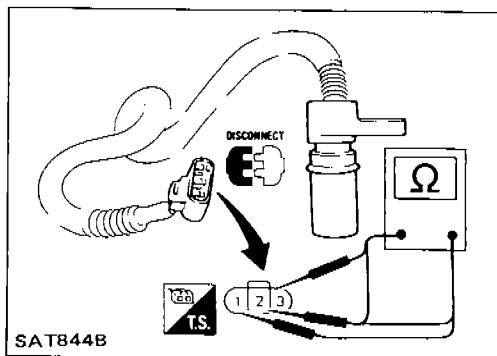
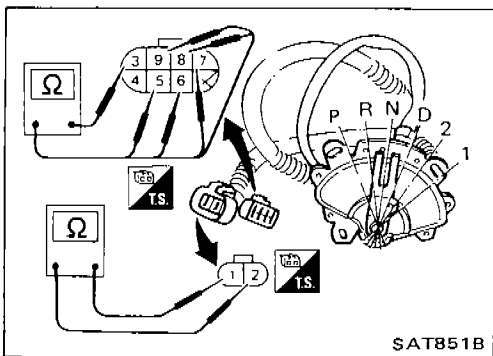
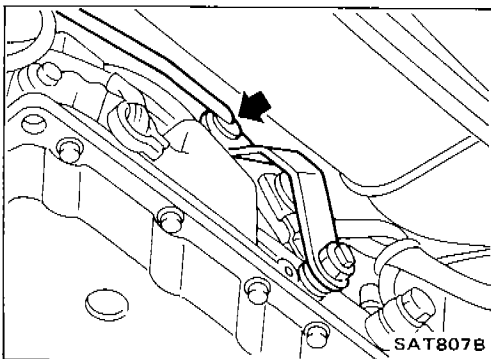
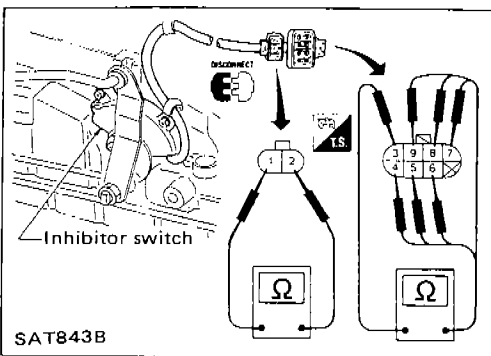
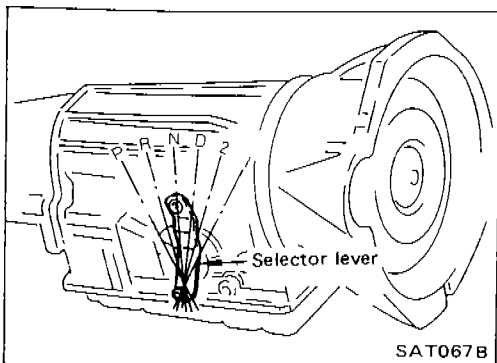

2. If N.G., check again with manual control linkage disconnected from manual shaft of A/T assembly. — Refer to step 1.
3. If O.K. on step 2, adjust manual control linkage. — Refer to "ON-VEHICLE SERVICE".
4. If N.G. on step 2, remove inhibitor switch from A/T and check continuity of inhibitor switch terminal. — Refer to step 1.
5. If O.K. on step 4, adjust inhibitor switch. — Refer to "ON-VEHICLE SERVICE".
6. If N.G. on step 4, replace inhibitor switch.

REVOLUTION SENSOR

- For removal and installation, refer to "ON-VEHICLE SERVICE".
- Check resistance between terminals ①, ② and ③.

| Terminal No. | | Resistance |
|--------------|---|---------------|
| ① | ② | 500 - 650Ω |
| ② | ③ | No continuity |
| ① | ③ | No continuity |

TROUBLE DIAGNOSES

Electrical Components Inspection (Cont'd)

FLUID TEMPERATURE SENSOR

- For removal and installation, refer to "ON-VEHICLE SERVICE".
- Check resistance between two terminals while changing temperature as shown at left.

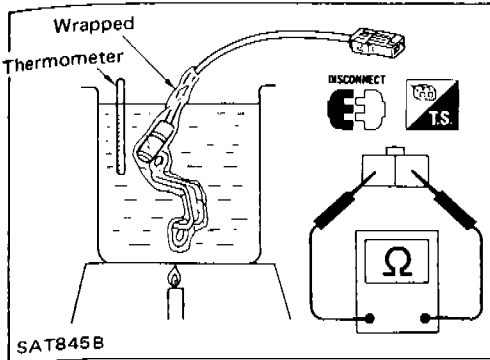

| Temperature °C (°F) | Resistance |
|---------------------|----------------------|
| 20 (68) | Approximately 2.5 kΩ |
| 80 (176) | Approximately 0.3 kΩ |

LOCK-UP SOLENOID AND LINE PRESSURE SOLENOID

- For removal and installation, refer to "ON-VEHICLE SERVICE".
- Check resistance between two terminals.

Resistance:

Lock-up solenoid 10 - 16 Ω

Line pressure solenoid 2.5 - 5 Ω

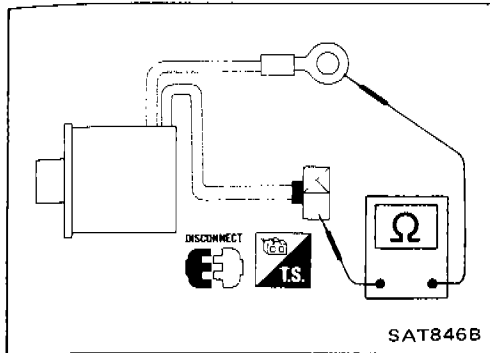

3-UNIT SOLENOID ASSEMBLY

(Shift solenoid A, B and overrun clutch solenoid)

- For removal and installation, refer to "ON-VEHICLE SERVICE".
- Check resistance between terminals of each solenoid.

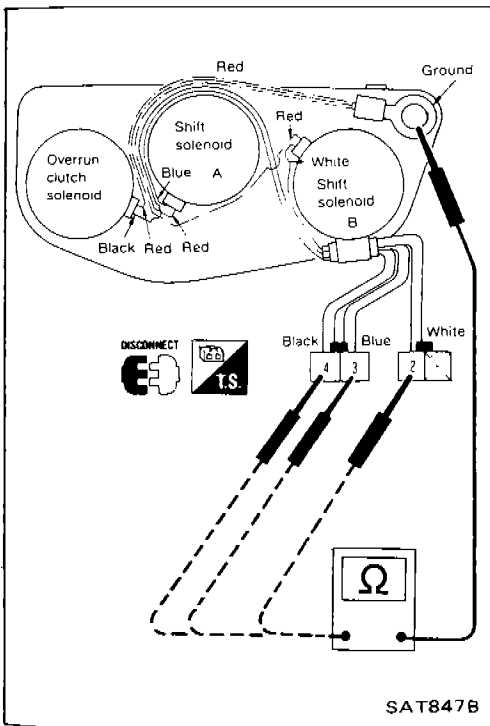

| Solenoid | Terminal No. | Resistance |
|-------------------------|--------------|-----------------------------|
| Shift solenoid A | ③ | Ground terminal 20 - 30Ω |
| Shift solenoid B | ② | |
| Overrun clutch solenoid | ④ | |

DROPPING RESISTOR

- Check resistance between two terminals.

Resistance: 11.2 - 12.8 Ω

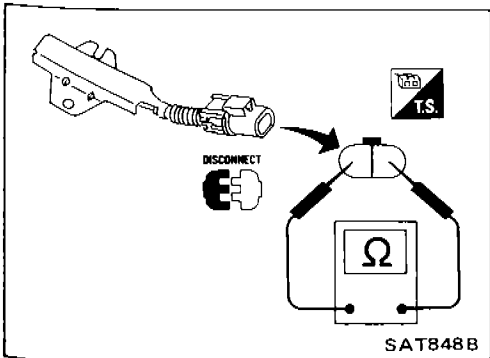

TROUBLE DIAGNOSES

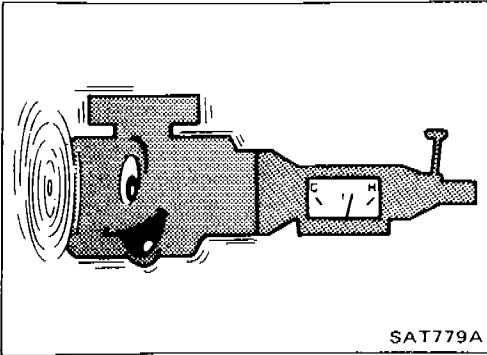

Final Check

STALL TESTING

Stall test procedure

1. Check A/T and engine fluid levels. If necessary, add.
2. Warm up engine until engine oil and A.T.F. reach operating temperature after vehicle has been driven approx. 10 minutes.

A.T.F. operating temperature:

50 - 80°C (122 - 176°F)

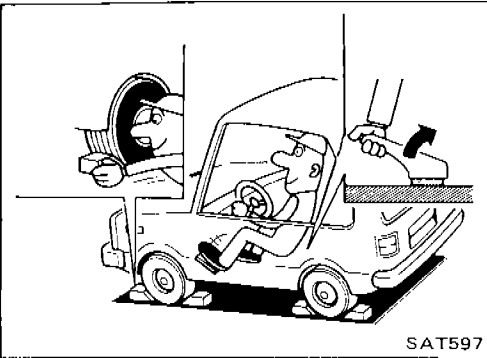

3. Set parking brake and block wheels.
4. Install a tachometer where it can be seen by driver during test.

● It is good practice to put a mark on point of specified engine rpm on indicator.

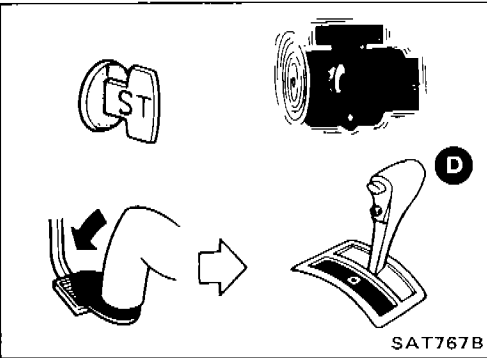

5. Start engine, apply foot brake, and place selector lever in "D" range.

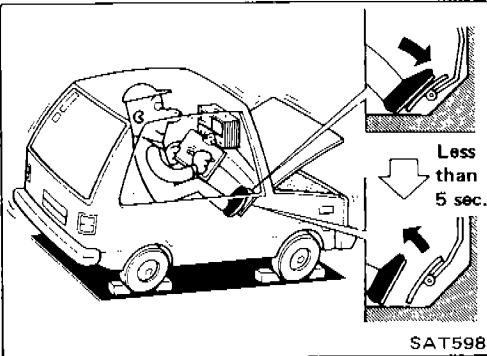

6. Accelerate to wide-open throttle gradually while applying foot brake.
7. Quickly note the engine stall revolution and immediately release throttle.

● During test, never hold throttle wide-open for more than 5 seconds.

Stall revolution:

3,050 - 3,250 rpm

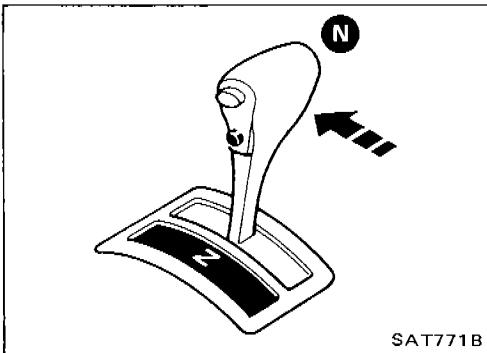

8. Shift selector lever to "N".

9. Cool off A.T.F.

● Run engine at idle for at least one minute.

10. Perform stall tests in the same manner as in steps 5 through 9 with selector lever in "2", "1" and "R", respectively.

TROUBLE DIAGNOSES

Final Check (Cont'd)

Judgement of stall test

| Selector lever position | Judgement | | |
|-------------------------|-----------|---|---|
| D | L | O | H |
| 2 | L | O | H |
| 1 | L | O | O |
| R | L | H | H |

- O : Stall revolution is normal.
- H : Stall revolution is higher than specified.
- L : Stall revolution is lower than specified.

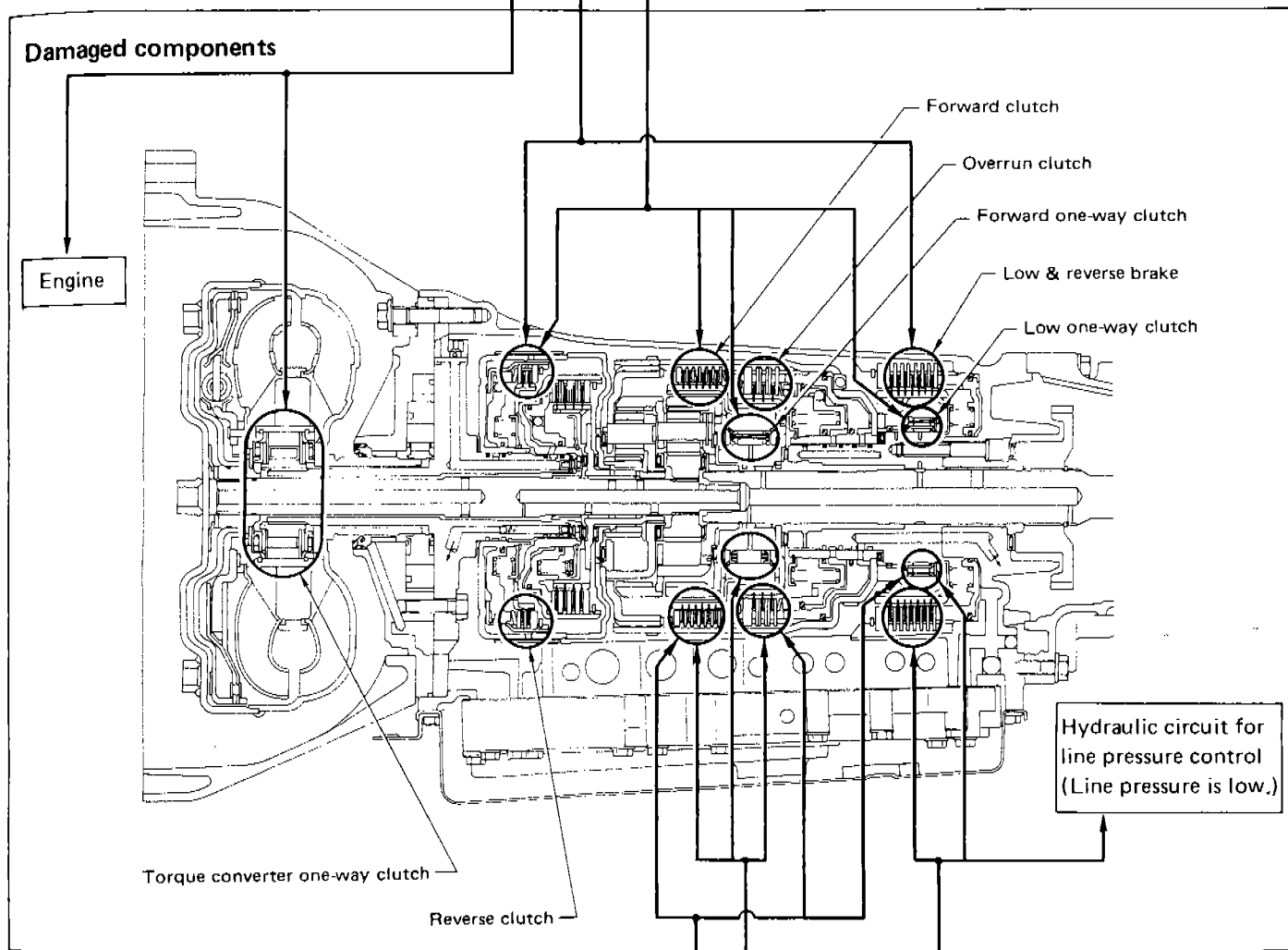

| D | H | H | H | O |
|-------------------------|-----------|---|---|---|
| 2 | H | H | H | O |
| 1 | O | H | H | O |
| R | O | O | H | O |
| Selector lever position | Judgement | | | |

Clutches and brakes except high clutch and brake band are O.K. (Condition of high clutch and brake band cannot be confirmed by stall test.)

SAT107B

TROUBLE DIAGNOSES

Final Check (Cont'd)

PRESSURE TESTING

- Location of line pressure test port
- Line pressure plugs are hexagon headed bolts.
- Always replace line pressure plugs as they are self-sealing bolts.

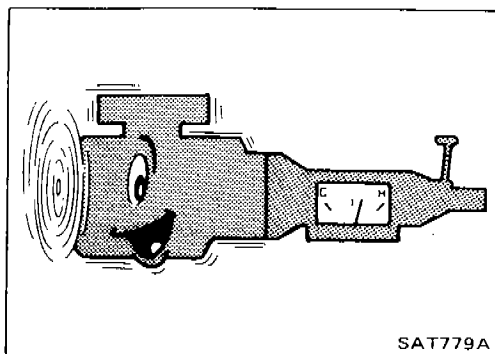
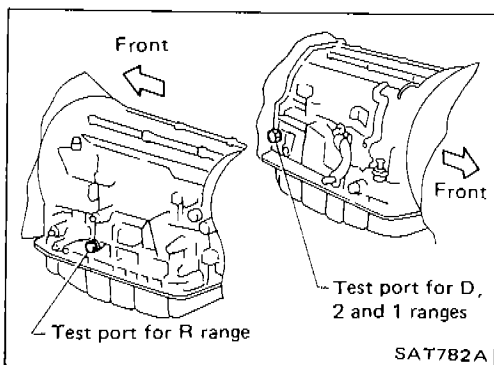

Line pressure test procedure

1. Check A/T and engine fluid levels. If necessary, add.
2. Warm up engine until engine oil and A.T.F. reach operating temperature after vehicle has been driven approx. 10 minutes.

A.T.F. operating temperature:

50 - 80°C (122 - 176°F)

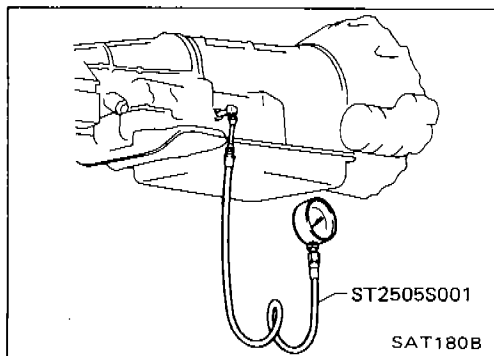

3. Install pressure gauge to line pressure port.

— D, 2 and 1 ranges —

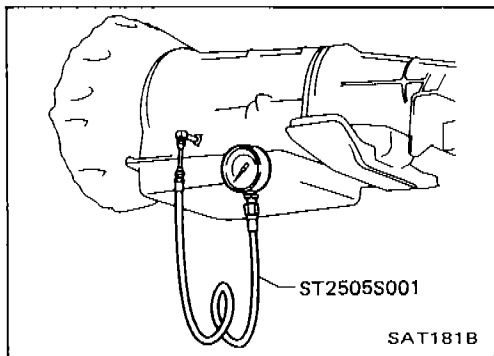

— R range —

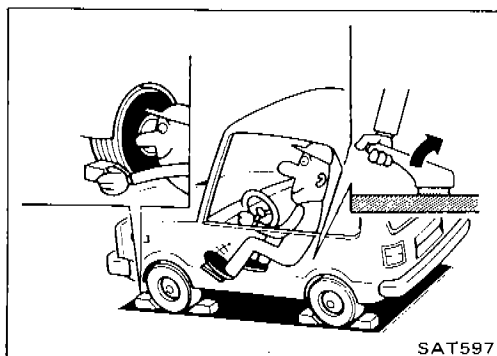

4. Set parking brake and block wheels.

- Continue to depress brake pedal fully while line pressure test at stall speed is performed.

TROUBLE DIAGNOSES

Final Check (Cont'd)

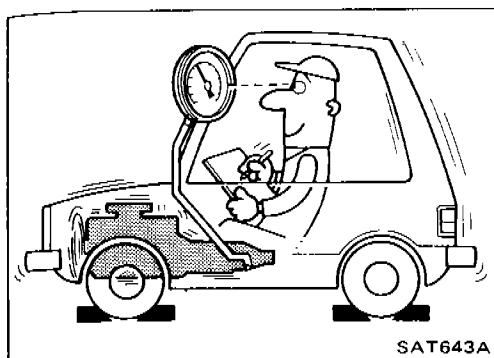

5. Start engine and measure line pressure at idle and stall speed.

- When measuring line pressure at stall speed, follow the stall test procedure.

Line pressure:

| Engine speed rpm | Line pressure kPa (bar, kg/cm ² , psi) | |
|---------------------|----------------------------------------------------------|----------------------------------------------------------|
| | D, 2 and 1 ranges | R range |
| Idle | 471 - 510 (4.71 - 5.10, 4.8 - 5.2, 68 - 74) | 657 - 696 (6.57 - 6.96, 6.7 - 7.1, 95 - 101) |
| Stall | 1,020 - 1,098 (10.20 - 10.98, 10.4 - 11.2, 148 - 159) | 1,422 - 1,500 (14.22 - 15.00, 14.5 - 15.3, 206 - 218) |

JUDGEMENT OF LINE PRESSURE TEST

| Judgement | | Suspected parts |
|----------------|-------------------------------------------|----------------------------------------------------------------------------------------------------------------------------------------------------------------------------------------------------------------------------------------------------------------------------------------------------------------------------------------------------------------|
| At idle | Line pressure is low in all ranges. | <ul style="list-style-type: none"> ● Oil pump wear ● Control piston damage ● Pressure regulator valve or plug sticking ● Spring for pressure regulator valve damaged ● Fluid pressure leakage between oil strainer and pressure regulator valve |
| | Line pressure is low in particular range. | <ul style="list-style-type: none"> ● Fluid pressure leakage between manual valve and particular clutch. ● For example; If line pressure is low in "R" and "1" ranges but is normal in "D" and "2" range, fluid leakage exists at or around low & reverse brake circuit. |
| | Line pressure is high. | <ul style="list-style-type: none"> ● Mal-adjustment of throttle sensor ● Fluid temperature sensor damaged ● Line pressure solenoid sticking ● Short circuit of line pressure solenoid circuit ● Pressure modifier valve sticking ● Pressure regulator valve or plug sticking |
| At stall speed | Line pressure is low. | <ul style="list-style-type: none"> ● Mal-adjustment of throttle sensor ● Control piston damaged ● Line pressure solenoid sticking ● Short circuit of line pressure solenoid circuit ● Pressure regulator valve or plug sticking ● Pressure modifier valve sticking ● Pilot valve sticking |

TROUBLE DIAGNOSES

Symptom Chart

| Reference page (AT-) | Reference page (AT-) | ON vehicle | | | | | | | | | | OFF vehicle | | | | | | | | | | | | | | | | | | | | | | |
|-----------------------|---------------------------------------------------------------------------------------------------------------------------------------------------------------------------------------------|--------------------------------|------------------|------------------------------|------------------------------------|--------------------------|-------------------|---------------|------------------------|------------------|------------------|------------------------|------------------|-------------------------|--------------------------|-----------------|-----------------|-----------------|-----------------------|-----------------------------|------------------|----------|----------------|-------------|----------------|------------------------|----------------|--------------------|---------------------|------------|--------------------|---|---|--|
| | | 9, 14 | 66 | 66 | 70 | 67, 96 | 67 | 67 | 7, 67 | 7 | 7 | 80, 91 | 110, 114 | 116, 127 | 116, 124 | 120 | 134 | | | | | | | | | | | | | | | | | |
| | Numbers are arranged in order of probability. Perform inspections starting with number one and working up. Circled numbers indicate that the transmission must be removed from the vehicle. | Fluid level Control linkage | Inhibitor switch | Throttle sensor (Adjustment) | Revolution sensor and speed sensor | Engine revolution signal | Engine idling rpm | Line pressure | Control valve assembly | Shift solenoid A | Shift solenoid B | Line pressure solenoid | Lock-up solenoid | Overrun clutch solenoid | Fluid temperature sensor | Accumulator N-D | Accumulator 1-2 | Accumulator 2-3 | Accumulator 3-4 (N-R) | Ignition switch and starter | Torque converter | Oil pump | Reverse clutch | High clutch | Forward clutch | Forward one-way clutch | Overrun clutch | Low one-way clutch | Low & reverse brake | Brake band | Parking components | | | |
| 48 | Engine does not start in "N", "P" ranges. | 2 | 3 | | | | | | | | | | | | | | | | 1 | | | | | | | | | | | | | | | |
| 48 | Engine starts in range other than "N" and "P". | 1 | 2 | | | | | | | | | | | | | | | | | | | | | | | | | | | | | | | |
| - | Transmission noise in "P" and "N" ranges. | 1 | | 3 | 4 | 5 | 2 | | | | | | | | | | | | | | 7 | 6 | | | | | | | | | | | | |
| 48 | Vehicle moves when changing into "P" range or parking gear does not disengage when shifted out of "P" range. | 1 | | | | | | | | | | | | | | | | | | | | | | | | | | | | | | 2 | | |
| 49 | Vehicle runs in "N" range. | 1 | | | | | | | | | | | | | | | | | 4 | | | | 3 | 2 | 3 | | | | | | | | | |
| 51 | Vehicle will not run in "R" range (but runs in "D", "2" and "1" ranges). Clutch slips. Very poor acceleration. | 1 | | | | 2 | 4 | | | 3 | | | | | | | | | | | | 5 | 6 | 7 | 8 | 9 | | | | | | | | |
| - | Vehicle braked when shifting into "R" range. | 1 | 2 | | | 3 | 5 | | | 4 | | | | | | | | | | | | | 6 | 8 | 9 | | | | | 7 | | | | |
| - | Sharp shock in shifting from "N" to "D" range. | | | 2 | 5 | 1 | 3 | 7 | | 6 | | 4 | 8 | | | | | | | | | | | 9 | | | | | | | | | | |
| - | Vehicle will not run in "D" and "1" ranges (but runs in "1" and "R" range). | 1 | | | | | | | | | | | | | | | | | | | | | | | | | 2 | | | | | | | |
| 52 | Vehicle will not run in "D", "1", "2" ranges (but runs in "R" range). Clutch slips. Very poor acceleration. | 1 | | | | 2 | 4 | | | 3 | | | | | | | | | | | | | 6 | 7 | 8 | 9 | 10 | | | | | | | |
| - | Clutches or brakes slip somewhat in starting. | 1 | 2 | 3 | | 4 | 6 | | 5 | | | 7 | | 8 | | 10 | 12 | | | | 11 | 12 | 10 | 9 | | | | | 11 | | | | | |
| - | Excessive creep. | | | | | 1 | | | | | | | | | | | | | | | | | | | | | | | | | | | | |
| 51, 52 | No creep at all. | 1 | | | | 2 | 3 | | | | | | | | | | | | | | | 6 | 5 | | 4 | | | | | | | | | |
| - | Failure to change gear from "D ₁ " to "D ₂ ". | 2 | 1 | 5 | | 4 | 3 | | | | | | | | | | | | | | | | | | | | | | | | 6 | | | |
| - | Failure to change gear from "D ₂ " to "D ₃ ". | 2 | 1 | 5 | | 4 | 3 | | | | | | | | | | | | | | | | 6 | | | | | | | | 7 | | | |
| - | Failure to change gear from "D ₃ " to "D ₄ ". | 2 | 1 | 4 | | | 3 | | | | | 5 | | | | | | | | | | | | | | | | | | | 6 | | | |
| 54, 55, 56 | Too high a gear change point from "D ₁ " to "D ₂ ", from "D ₂ " to "D ₃ ", from "D ₃ " to "D ₄ ". | | | 1 | 2 | | 3 | 4 | | | | | | | | | | | | | | | | | | | | | | | | | | |
| - | Gear change directly from "D ₁ " to "D ₃ " occurs. | 1 | | | | | | | | | | | | | 2 | | | | | | | | | | | | | | | | | 3 | | |
| - | Engine stops when shifting lever into "R", "D", "2" and "1". | | | | 1 | 3 | | | | 2 | | | | | | | | | | | 4 | | | | | | | | | | | | | |
| - | Too sharp a shock in change from "D ₁ " to "D ₂ ". | | | 1 | | 2 | 4 | | | | | 5 | 3 | | | | | | | | | | | | | | | | | | | 6 | | |
| - | Too sharp a shock in change from "D ₂ " to "D ₃ ". | | | 1 | | 2 | 4 | | | | | | | | | | | | 3 | | | | | | | | | | | | | | 6 | |

TROUBLE DIAGNOSES

Symptom Chart (Cont'd)

| Reference page (AT-) | Reference page (AT-) | ON vehicle | | | | | | | | | | OFF vehicle | | | | | | | | | | | | | | | | | | | | | | |
|-----------------------|----------------------------------------------------------------------------------------------------------------------------------------------------------------|-------------|-----------------|------------------|------------------------------|------------------------------------|--------------------------|-------------------|---------------|------------------------|------------------|------------------|------------------------|------------------|-------------------------|--------------------------|-----------------|-----------------|-----------------|-----------------------|-----------------------------|------------------|----------|----------------|-------------|----------------|------------------------|----------------|--------------------|---------------------|------------|--------------------|---|---|
| | | 9, 14 | 66 | 66 | 70 | 67, 96 | 67 | 67 | 7, 67 | 7 | 7 | 80, 91 | 110, 114 | 116, 127 | 116, 124 | 120 | 134 | | | | | | | | | | | | | | | | | |
| | | Fluid level | Control linkage | Inhibitor switch | Throttle sensor (Adjustment) | Revolution sensor and speed sensor | Engine revolution signal | Engine idling rpm | Line pressure | Control valve assembly | Shift solenoid A | Shift solenoid B | Line pressure solenoid | Lock-up solenoid | Overrun clutch solenoid | Fluid temperature sensor | Accumulator N-D | Accumulator 1-2 | Accumulator 2-3 | Accumulator 3-4 (N-R) | Ignition switch and starter | Torque converter | Oil pump | Reverse clutch | High clutch | Forward clutch | Forward one-way clutch | Overrun clutch | Low one-way clutch | Low & reverse brake | Brake band | Parking components | | |
| - | Too sharp a shock in change from "D ₃ " to "D ₄ ". | . | . | 1 | . | . | . | 2 | 4 | . | . | . | . | . | . | . | . | . | 3 | . | . | . | . | . | . | 6 | . | 5 | . | . | . | | | |
| - | Almost no shock or clutches slipping in change from "D ₁ " to "D ₁ ". | 1 | . | 2 | . | . | . | 3 | 5 | . | . | . | . | . | . | . | 4 | . | . | . | . | . | . | . | . | . | . | . | 6 | . | . | . | | |
| - | Almost no shock or slipping in change from "D ₁ " to "D ₃ ". | 1 | . | 2 | . | . | . | 3 | 5 | . | . | . | . | . | . | . | . | 4 | . | . | . | . | . | . | 6 | . | . | . | 7 | . | . | . | | |
| - | Almost no shock or slipping in change from "D ₃ " to "D ₄ ". | 1 | . | 2 | . | . | . | 3 | 5 | . | . | . | . | . | . | . | . | . | 4 | . | . | . | . | . | 6 | . | . | . | 7 | . | . | . | | |
| - | Vehicle braked by gear change from "D ₁ " to "D ₃ ". | 1 | . | . | . | . | . | . | . | . | . | . | . | . | . | . | . | . | . | . | . | . | . | 2 | 4 | . | . | 5 | 3 | . | . | . | | |
| - | Vehicle braked by gear change from "D ₁ " to "D ₃ ". | 1 | . | . | . | . | . | . | . | . | . | . | . | . | . | . | . | . | . | . | . | . | . | . | . | . | . | . | . | 2 | . | . | . | |
| - | Vehicle braked by gear change from "D ₃ " to "D ₄ ". | 1 | . | . | . | . | . | . | . | . | . | . | . | . | . | . | . | . | . | . | . | . | . | 4 | . | . | 3 | 2 | . | . | . | . | . | |
| - | Maximum speed not attained. Acceleration poor. | 1 | . | 2 | . | . | . | . | 5 | 3 | 4 | . | . | . | . | . | . | . | . | . | . | 11 | 10 | 6 | 7 | . | . | . | 9 | 8 | . | . | . | |
| - | Failure to change gear from "D ₄ " to "D ₃ ". | 1 | . | 2 | . | . | . | . | 6 | 4 | 5 | 3 | . | . | . | . | . | . | . | . | . | . | . | . | . | . | 8 | 7 | . | . | . | . | . | |
| - | Failure to change gear from "D ₃ " to "D ₃ " or from "D ₄ " to "D ₁ ". | 1 | . | 2 | . | . | . | . | 5 | 3 | 4 | . | . | . | . | . | . | . | . | . | . | . | . | 6 | . | . | . | . | 7 | . | . | . | . | |
| - | Failure to change gear from "D ₁ " to "D ₁ " or from "D ₃ " to "D ₁ ". | 1 | . | 2 | . | . | . | . | 5 | 3 | 4 | . | . | . | . | . | . | . | . | . | . | . | . | 7 | . | . | 6 | 8 | . | . | . | . | . | |
| - | Gear change shock felt during deceleration by releasing accelerator pedal. | . | . | 1 | . | . | 2 | 4 | . | . | . | 3 | . | . | . | . | . | . | . | . | . | . | . | . | . | . | . | . | . | . | . | . | . | |
| - | Too high a change point from "D ₄ " to "D ₃ ", from "D ₃ " to "D ₂ ", from "D ₁ " to "D ₁ ". | . | . | 1 | 2 | . | . | . | . | . | . | . | . | . | . | . | . | . | . | . | . | . | . | . | . | . | . | . | . | . | . | . | . | . |
| - | Kickdown does not operate when depressing pedal in "D ₄ " within kickdown vehicle speed. | . | . | 1 | 2 | . | . | . | 3 | 4 | . | . | . | . | . | . | . | . | . | . | . | . | . | . | . | . | . | . | . | . | . | . | . | . |
| - | Kickdown operates or engine overruns when depressing pedal in "D ₄ " beyond kickdown vehicle speed limit. | . | . | 2 | 1 | . | . | . | 3 | 4 | . | . | . | . | . | . | . | . | . | . | . | . | . | . | . | . | . | . | . | . | . | . | . | . |
| - | Races extremely fast or slips in changing from "D ₄ " to "D ₃ " when depressing pedal. | 1 | . | 2 | . | . | 3 | 5 | . | 4 | . | . | . | . | . | . | . | . | . | . | . | . | . | . | 6 | 7 | . | . | . | . | . | . | . | . |
| - | Races extremely fast or slips in changing from "D ₄ " to "D ₁ " when depressing pedal. | 1 | . | 2 | . | . | 3 | 6 | 5 | 4 | . | . | . | . | . | . | . | . | . | . | . | . | . | . | . | 8 | . | . | 7 | . | . | . | . | . |
| - | Races extremely fast or slips in changing from "D ₃ " to "D ₁ " when depressing pedal. | 1 | . | 2 | . | . | 3 | 5 | . | 4 | . | . | 8 | . | 0 | . | . | . | . | . | . | . | . | 9 | 7 | . | . | 6 | . | . | . | . | . | . |
| - | Races extremely fast or slips in changing from "D ₄ " or "D ₃ " to "D ₁ " when depressing pedal. | 1 | . | 2 | . | . | 3 | 5 | . | 4 | . | . | . | . | . | . | . | . | . | . | . | . | . | . | 6 | 7 | . | 8 | . | . | . | . | . | . |
| - | Vehicle will not run in any range. | 1 | 2 | . | . | . | 3 | . | . | 4 | . | . | . | . | . | . | . | . | . | . | . | 9 | 5 | . | 6 | . | . | . | 8 | 7 | 10 | . | . | . |
| - | Transmission noise in "D", "2", "1" and "R" ranges. | 1 | . | . | . | . | . | . | . | . | . | . | . | . | . | . | . | . | . | . | . | 2 | . | . | . | . | . | . | . | . | . | . | . | . |

TROUBLE DIAGNOSES

Symptom Chart (Cont'd)

| Reference page (AT-) | Reference page (AT-) | ON vehicle | | | | | | | | | | OFF vehicle | | | | | | | | | | | | | | | | | | | | |
|-----------------------|---------------------------------------------------------------------------------------------|-------------|-----------------|------------------|------------------------------|------------------------------------|--------------------------|-------------------|---------------|------------------------|------------------|------------------|------------------------|------------------|-------------------------|--------------------------|-----------------|-----------------|-----------------------|-----------------------------|------------------|----------|----------------|-------------|----------------|------------------------|----------------|--------------------|---------------------|------------|--------------------|---|
| | | 9, 14 | 66 | 66 | 70 | 67, 96 | 67 | 67 | 7, 67 | 7 | 7 | 80, 91 | 110, 114 | 116, 127 | 116, 124 | 120 | 134 | | | | | | | | | | | | | | | |
| | | Fluid level | Control linkage | Inhibitor switch | Throttle sensor (Adjustment) | Revolution sensor and speed sensor | Engine revolution signal | Engine idling rpm | Line pressure | Control valve assembly | Shift solenoid A | Shift solenoid B | Line pressure solenoid | Lock-up solenoid | Overrun clutch solenoid | Fluid temperature sensor | Accumulator N-D | Accumulator 1-2 | Accumulator 3-4 (N-R) | Ignition switch and starter | Torque converter | Oil pump | Reverse clutch | High clutch | Forward clutch | Forward one-way clutch | Overrun clutch | Low one-way clutch | Low & reverse brake | Brake band | Parking components | |
| 61 | Failure to change from "D ₃ " to "2" when changing lever into "2" range. | . | 7 | 1 | 2 | . | . | . | . | 6 | 5 | 4 | . | . | 3 | . | . | . | . | . | . | . | . | . | . | . | 9 | . | 8 | . | . | |
| - | Gear change from "2" to "3" in "2" range. | . | . | 1 | . | . | . | . | . | . | . | . | . | . | . | . | . | . | . | . | . | . | . | . | . | . | . | . | . | . | . | |
| 61 | Engine brake does not operate in "1" range. | . | 2 | 1 | 3 | 4 | . | . | . | 6 | 5 | . | . | 7 | . | . | . | . | . | . | . | . | . | . | . | . | 8 | . | 9 | . | . | |
| - | Gear change from "1" to "1" in "1" range. | . | 2 | 1 | . | . | . | . | . | . | . | . | . | . | . | . | . | . | . | . | . | . | . | . | . | . | . | . | . | . | . | |
| - | Does not change from "1 ₁ " to "1 ₁ " in "1" range. | . | . | 1 | . | 2 | . | . | . | 4 | 3 | . | . | 5 | . | . | . | . | . | . | . | . | . | . | . | . | 6 | . | 7 | . | . | |
| - | Large shock changing from "1 ₁ " to "1 ₁ " in "1" range. | . | . | . | . | . | . | . | 1 | . | . | . | . | . | . | . | . | . | . | . | . | . | . | . | . | . | . | 2 | . | . | . | |
| - | Transmission overheats. | 1 | . | . | 3 | . | . | 2 | 4 | 6 | . | . | 5 | . | . | . | . | . | . | . | 14 | 7 | 8 | 9 | 11 | . | 12 | . | 13 | 10 | . | |
| - | A.T.F. shoots out during operation. White smoke emitted from exhaust pipe during operation. | 1 | . | . | . | . | . | . | . | . | . | . | . | . | . | . | . | . | . | . | . | . | 2 | 3 | 5 | . | 6 | . | 7 | 4 | . | |
| - | Offensive smell at fluid charging pipe. | 1 | . | . | . | . | . | . | . | . | . | . | . | . | . | . | . | . | . | . | . | 2 | 3 | 4 | 5 | 7 | . | 8 | . | 9 | 6 | . |
| - | Torque converter is not locked up. | . | . | 3 | 1 | 2 | 4 | . | 6 | 8 | . | . | 7 | . | 5 | . | . | . | . | . | 9 | . | . | . | . | . | . | . | . | . | . | . |
| - | Lock-up piston slip | 1 | . | . | 2 | . | . | 3 | 6 | . | 5 | 4 | . | . | . | . | . | . | . | . | 7 | . | . | . | . | . | . | . | . | . | . | . |
| 57 | Lock-up point is extremely high or low. | . | . | . | 1 | 2 | . | . | 4 | . | . | 3 | . | . | . | . | . | . | . | . | . | . | . | . | . | . | . | . | . | . | . | . |
| - | A/T does not shift to "D ₄ " when driving with overdrive switch "ON". | . | . | 2 | 1 | 3 | . | 8 | 6 | 4 | . | . | 5 | 7 | . | . | . | . | . | . | . | . | . | . | . | . | 10 | . | 9 | . | . | |
| - | Engine is stopped at "R", "D", "2" and "1" ranges. | 1 | . | . | . | . | . | . | 5 | 4 | 3 | . | 2 | . | . | . | . | . | . | . | . | . | . | . | . | . | . | . | . | . | . | . |

REMOVAL AND INSTALLATION

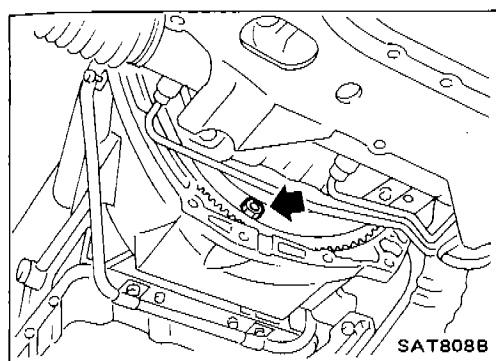

Removal

- Remove fluid charging pipe from A/T assembly.
- Remove bolts securing torque converter to drive plate.
- **Remove those bolts by turning crankshaft.**
- Plug up opening such as oil charging pipe hole, etc.

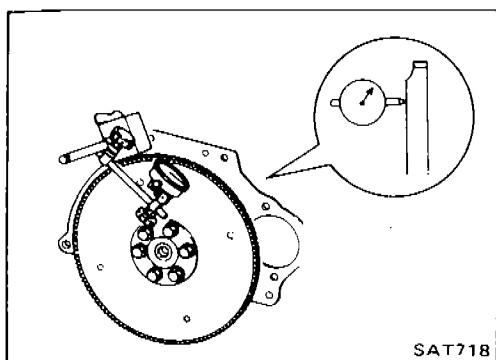

Installation

- Drive plate runout
**Maximum allowable runout:
 0.5 mm (0.020 in)**
 If this runout is out of allowance, replace drive plate with ring gear.

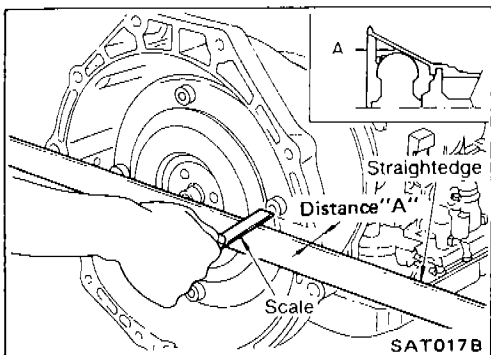

- When connecting torque converter to transmission, measure distance "A" to be certain that they are correctly assembled.
**Distance "A":
 23.5 mm (0.925 in) or more**
- Install converter to drive plate.
- Reinstall any part removed.
- **After converter is installed to drive plate, rotate crankshaft several turns and check to be sure that transmission rotates freely without binding.**

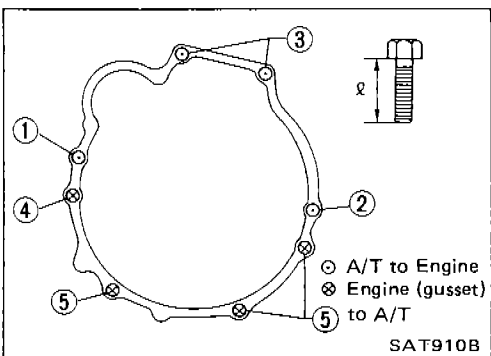

- Tighten bolts securing transmission.

| Bolt No. | Tightening torque N·m (kg·m, ft·lb) | Bolt length "L" mm (in) |
|------------------|-------------------------------------|-------------------------|
| 1 | 39 - 49 (4.0 - 5.0, 29 - 36) | 80 (3.15) |
| 2 | 39 - 49 (4.0 - 5.0, 29 - 36) | 75 (2.95) |
| 3 | 39 - 49 (4.0 - 5.0, 29 - 36) | 55 (2.17) |
| 4 | 29 - 39 (3.0 - 4.0, 22 - 29) | 40 (1.57) |
| 5 | 29 - 39 (3.0 - 4.0, 22 - 29) | 25 (0.98) |
| Gusset to engine | 29 - 39 (3.0 - 4.0, 22 - 29) | 20 (0.79) |



- Reinstall any part removed.
- Check fluid level in transmission.
- Move selector lever through all positions to be sure that transmission operates correctly.
 With parking brake applied, rotate engine at idling. Move selector lever through "N" to "D", to "2", to "1" and to "R". A slight shock should be felt by hand gripping selector each time transmission is shifted.
- Perform road test. — Refer to "ROAD TESTING".

MAJOR OVERHAUL

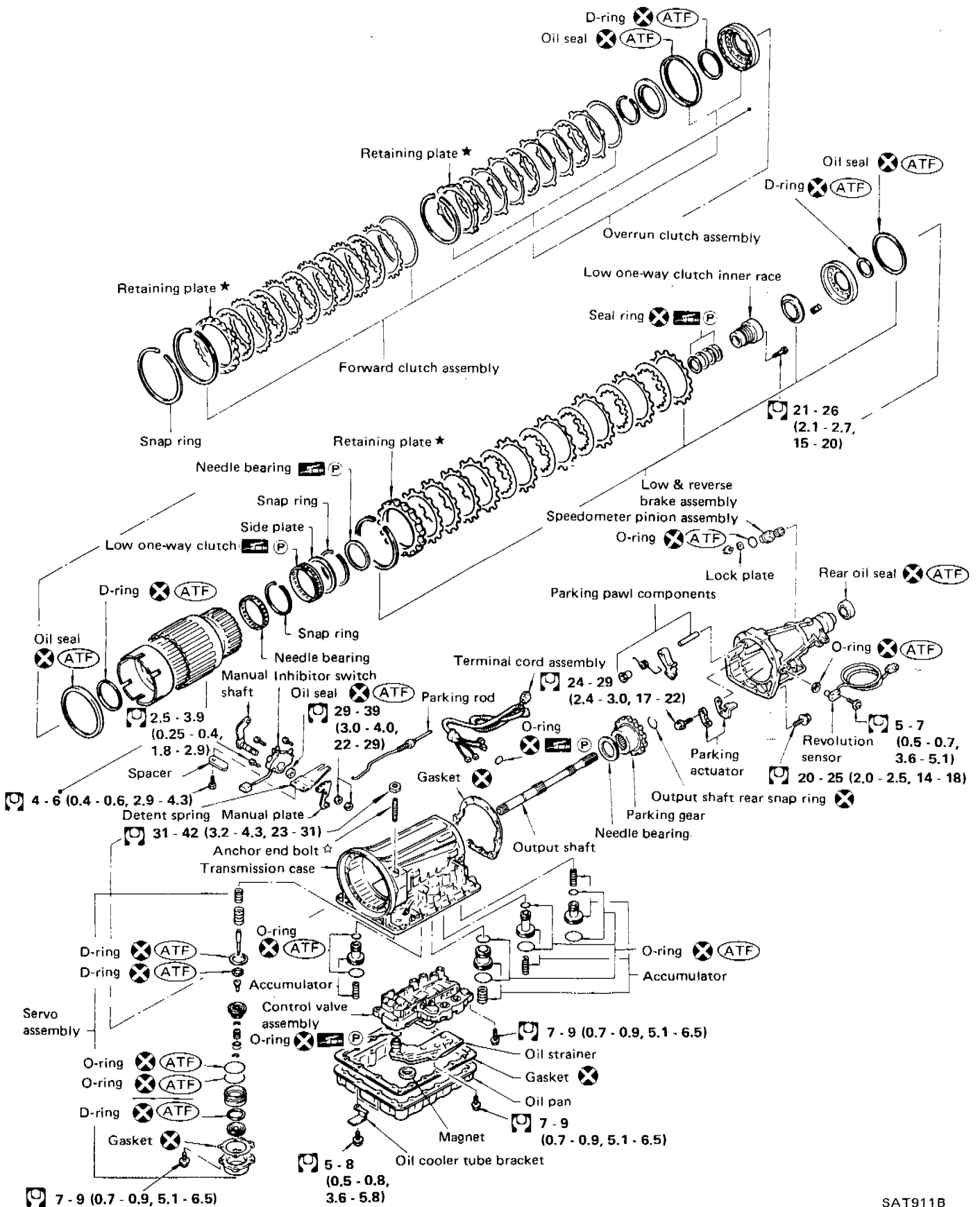

SAT911B

AT-77

MAJOR OVERHAUL

Oil Channel

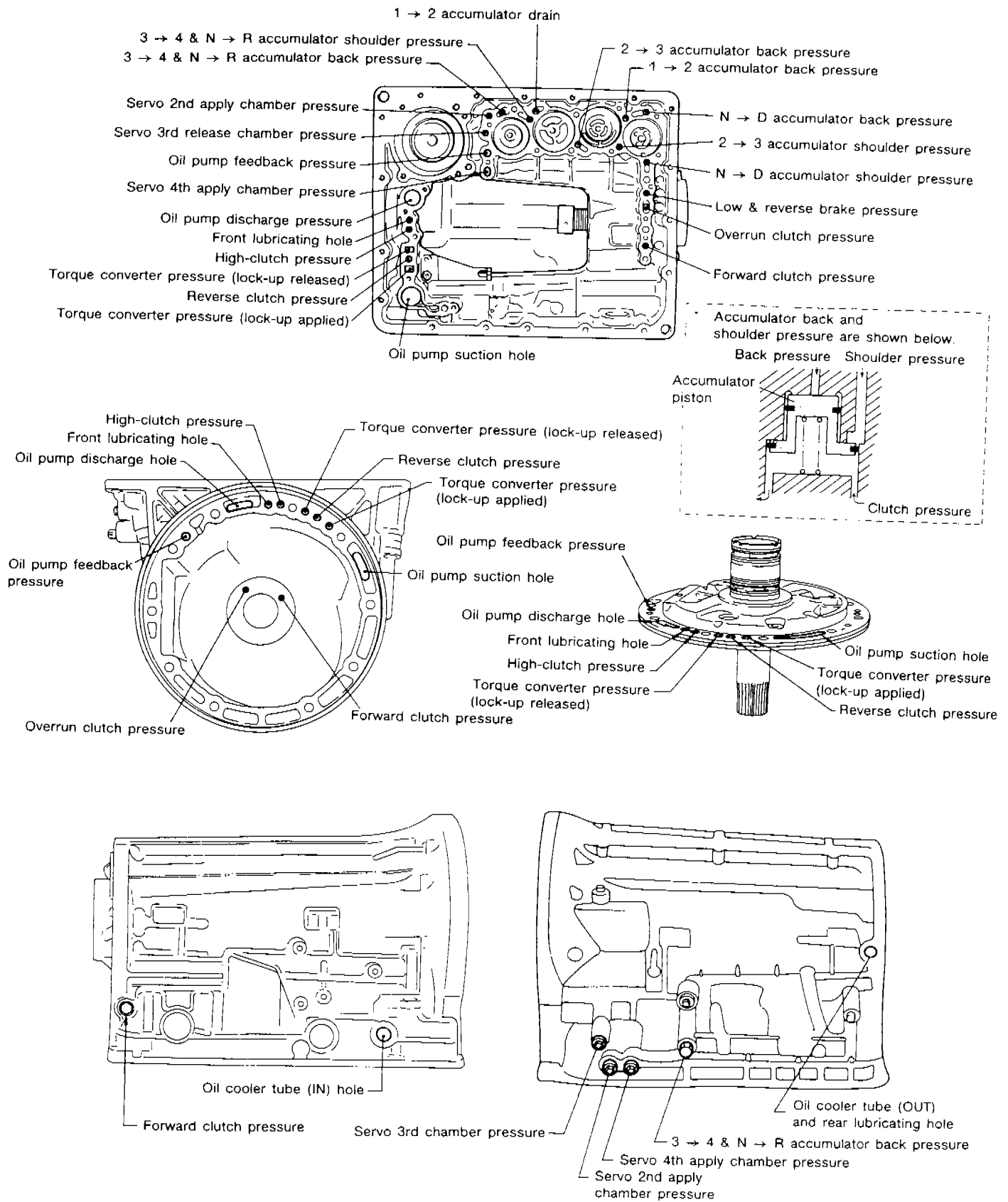

SAT185B

AT-78

MAJOR OVERHAUL

Locations of Needle Bearings, Thrust Washers and Snap Rings

Outer diameter of snap rings

| Item number | Outer diameter mm (in) |
|-------------|------------------------|
| ② | 161.0 (6.34) |
| ③ | 140.1 (5.52) |
| ④ | 156.4 (6.16) |
| ⑥ | 142.0 (5.59) |
| ⑦ | 159.2 (6.27) |

Thrust washers

| Item number | Color |
|-------------|-------|
| ① | Black |
| ⑤ | White |

Outer diameter of needle bearings

| Item number | Outer diameter mm (in) |
|-------------|------------------------|
| ⑧ | 47 (1.85) |
| ⑨ | 53 (2.09) |
| ⑩ | 53 (2.09) |
| ⑪ | 78 (3.07) |
| ⑫ | 53 (2.09) |
| ⑬ | 78 (3.07) |
| ⑭ | 59 (2.32) |
| ⑮ | 78 (3.07) |
| ⑯ | 64 (2.52) |

Inner diameter of bearing races

| Item number | Outer diameter mm (in) |
|-------------|------------------------|
| ⑪ | 58 (2.28) |
| ⑬ | 58.8 (2.315) |

Installation of one-piece bearings

| Item number | Bearing race (black) location |
|-------------|-------------------------------|
| ⑫ | Front |
| ⑮ | Rear side |
| ⑯ | Rear side |

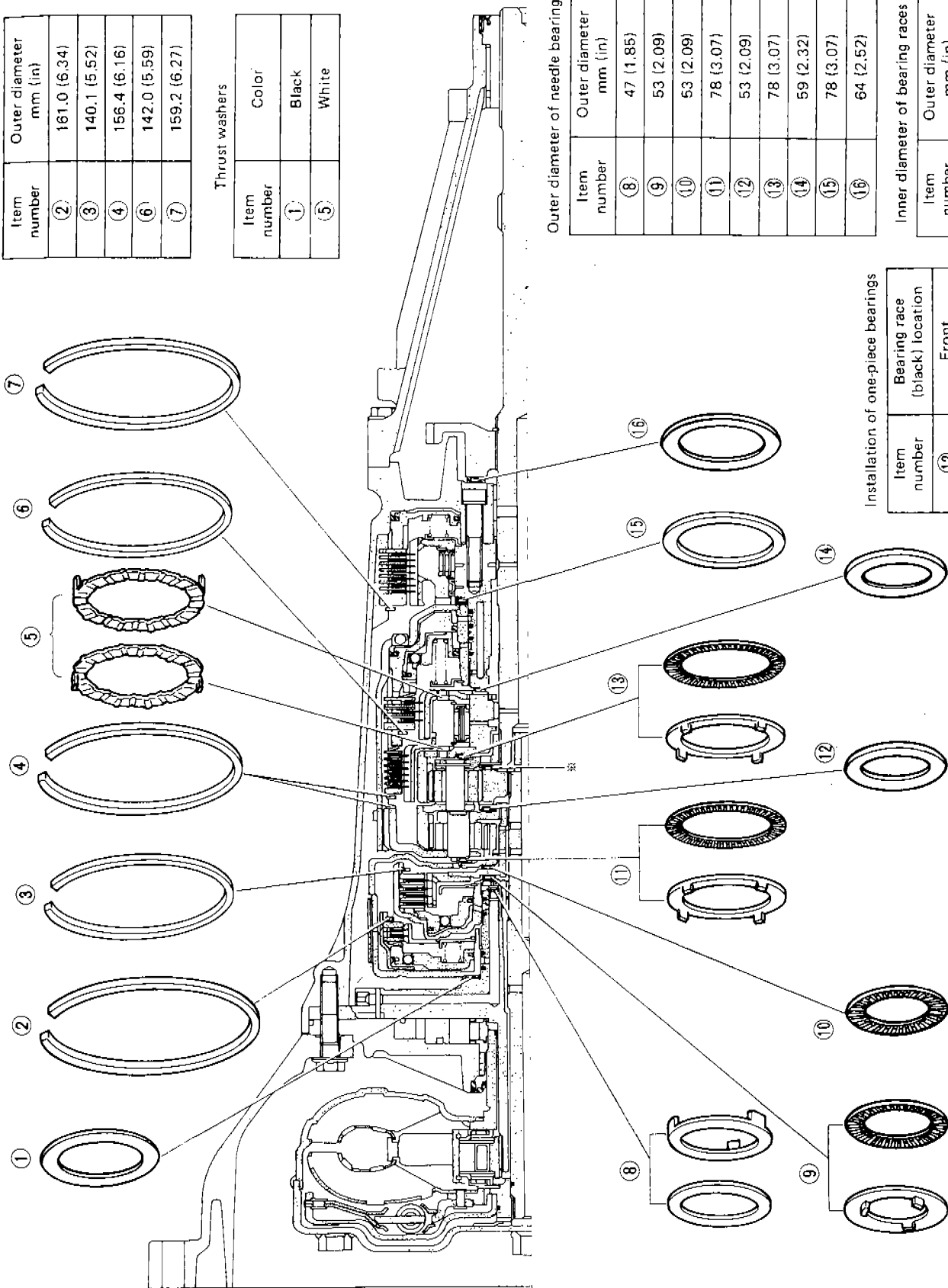

AT-79

SAT647A

DISASSEMBLY

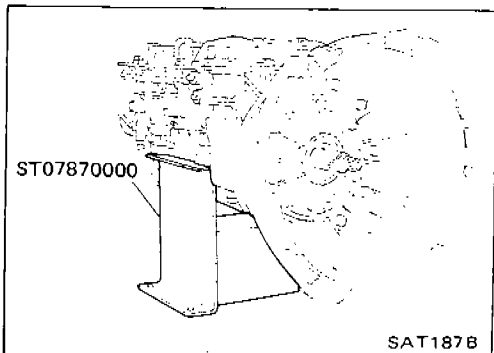
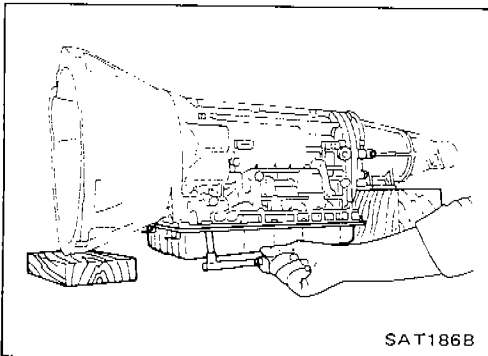
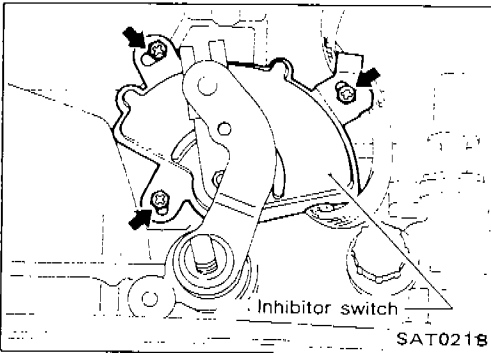
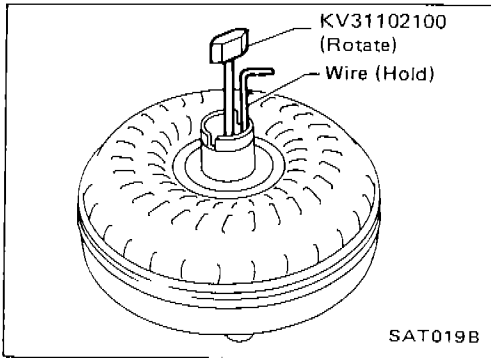
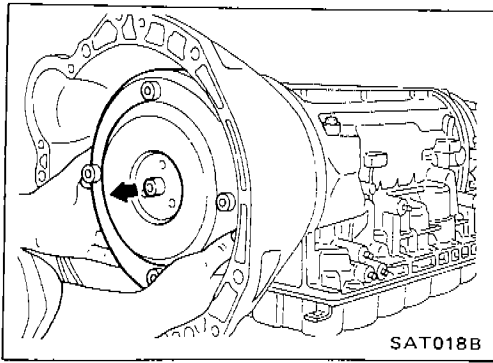

Disassembly

1. Remove torque converter by holding it firmly and turning while pulling straight out.
2. Check torque converter one-way clutch.
 - a. Insert Tool into spline of one-way clutch inner race.
 - b. Hook bearing support unitized with one-way clutch outer race with suitable wire.
 - c. Check that one-way clutch inner race rotates only clockwise with Tool while holding bearing support with wire.
3. Remove inhibitor switch from transmission case.
4. Remove oil pan.
 - a. Drain A.T.F. from rear extension.
 - b. Raise oil pan by placing wooden blocks under converter housing and rear extension.
 - c. Separate the oil pan and transmission case.
 - **Always place oil pan straight down so that foreign particles inside will not move.**
5. Place transmission into Tool with the control valve facing up.

DISASSEMBLY

Disassembly (Cont'd)

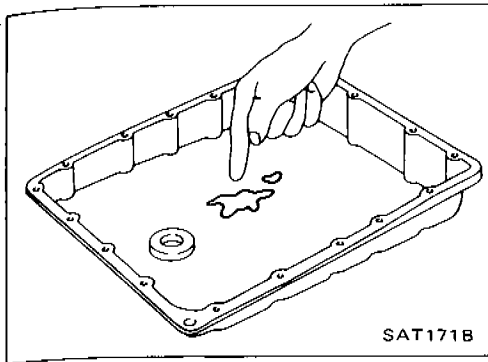

6. Check oil pan and oil strainer for accumulation of foreign particles.
- If materials of clutch facing are found, clutch plates may be worn.
 - If metal filings are found, clutch plates, brake bands, etc. may be worn.
 - If aluminum filings are found, bushings or aluminum cast parts may be worn.

In above cases, replace torque converter and check unit for cause of particle accumulation.

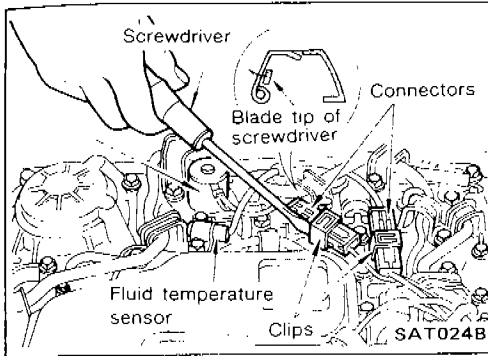

7. Remove lock-up solenoid and fluid temperature sensor connectors.

- **Be careful not to damage connector.**

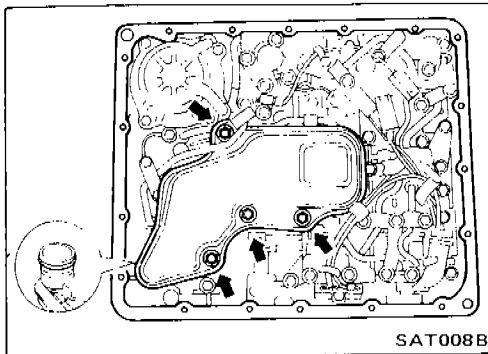

8. Remove oil strainer.
- a. Remove oil strainer from control valve assembly. Then remove O-ring from oil strainer.

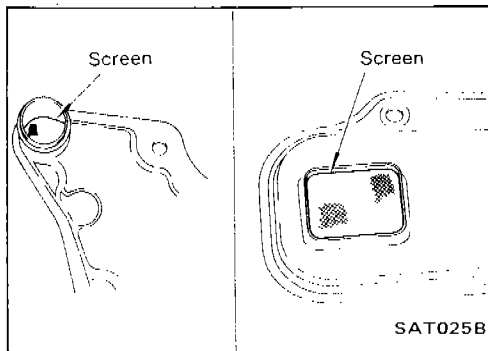

- b. Check oil strainer screen for damage.

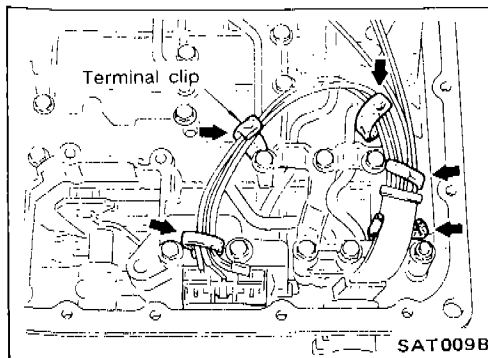

9. Remove control valve assembly.
- a. Straighten terminal clips to free terminal cords then remove terminal clips.

DISASSEMBLY

Disassembly (Cont'd)

- b. Remove bolts **(A)** and **(B)**, and remove control valve assembly from transmission.

| Bolt symbol | ℓ mm (in) |  ℓ |
|-------------|-----------|---------------------------------------------------------------------------------------|
| (A) | 33 (1.30) | |
| (B) | 45 (1.77) | |

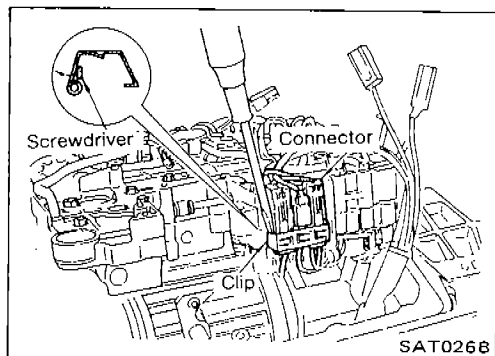
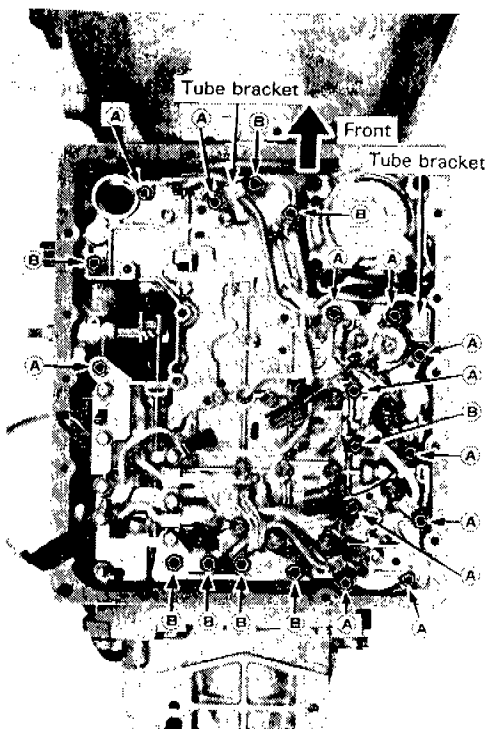

- c. Remove solenoid connector.
 ● Be careful not to damage connector.

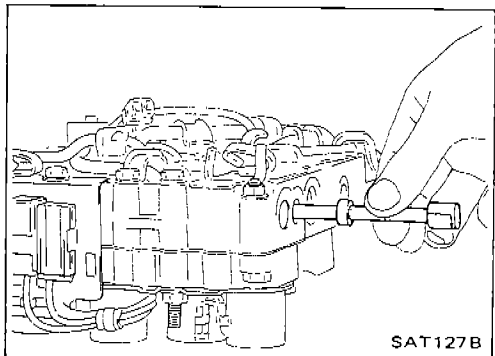

- d. Remove manual valve from control valve assembly.

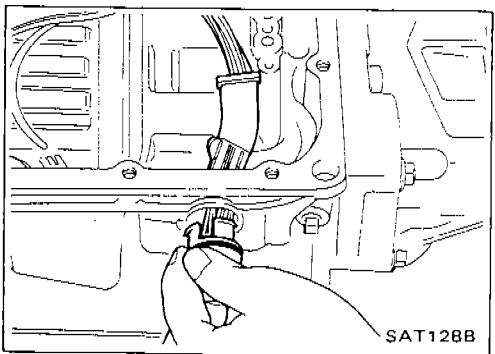

10. Remove terminal cord assembly from transmission case while pushing on stopper.
 ● Be careful not to damage cord.
 ● Do not remove terminal cord assembly unless it is damaged.

DISASSEMBLY

Disassembly (Cont'd)

11. Remove converter housing.
 - a. Remove converter housing from transmission case.

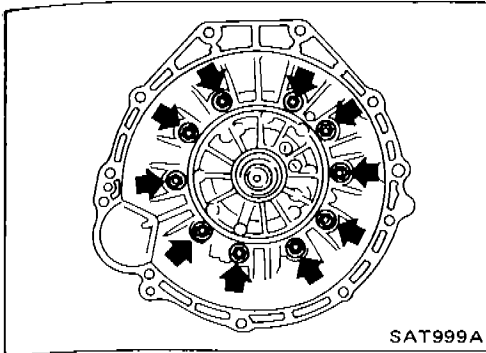

- b. Remove O-rings from converter housing.
 - c. Remove traces of sealant.
 - **Be careful not to scratch converter housing.**

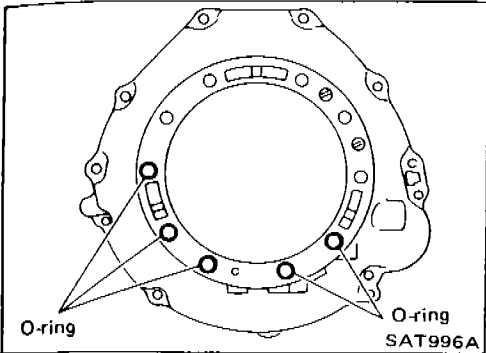

12. Remove O-ring from input shaft.

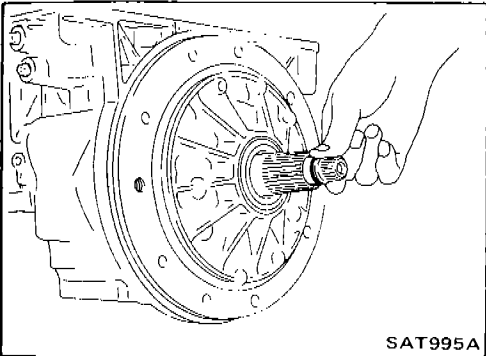

13. Remove oil pump assembly.
 - a. Attach Tool to oil pump assembly and extract it evenly from transmission case.

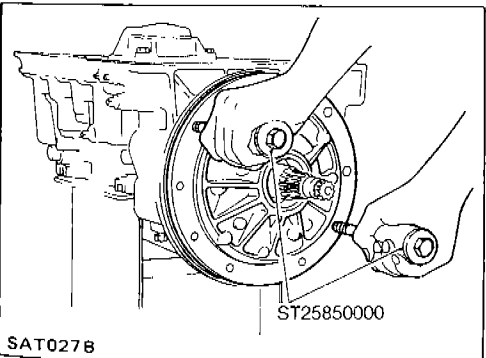

- b. Remove O-ring from oil pump assembly.
 - c. Remove traces of sealant from oil pump housing.
 - **Be careful not to scratch pump housing.**

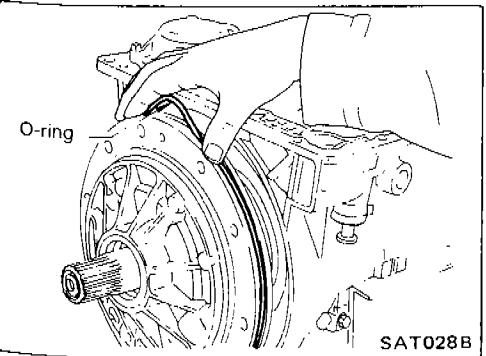

DISASSEMBLY

Disassembly (Cont'd)

- d. Remove needle bearing and thrust washer from oil pump assembly.

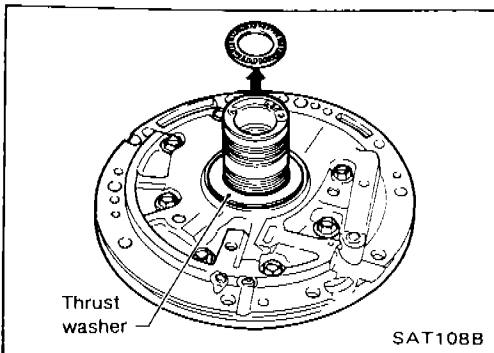

14. Remove input shaft and oil pump gasket.

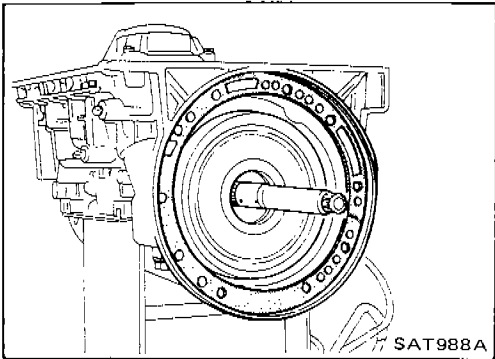

15. Remove brake band and band strut.
a. Loosen lock nut and remove band servo anchor end pin from transmission case.

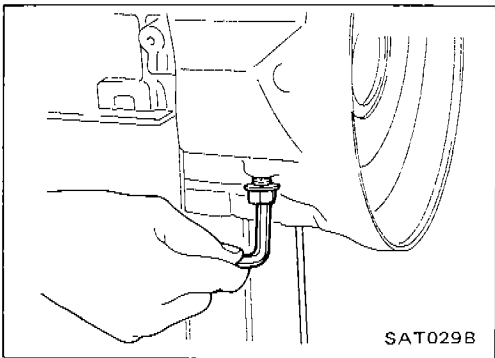

- b. Remove brake band and band strut from transmission case.

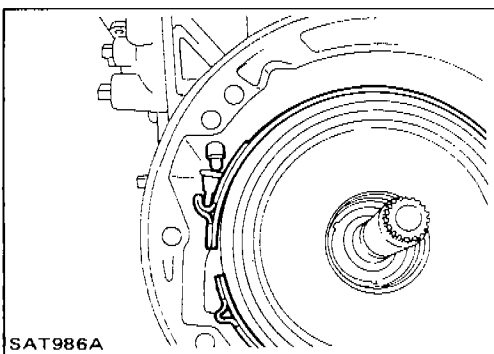

- c. Hold brake band in a circular shape with clip.

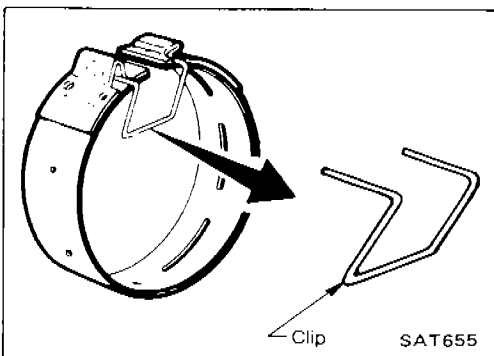

DISASSEMBLY

Disassembly (Cont'd)

16. Remove front side clutch and gear components.
- Remove clutch pack (reverse clutch, high clutch and front sun gear) from transmission case.

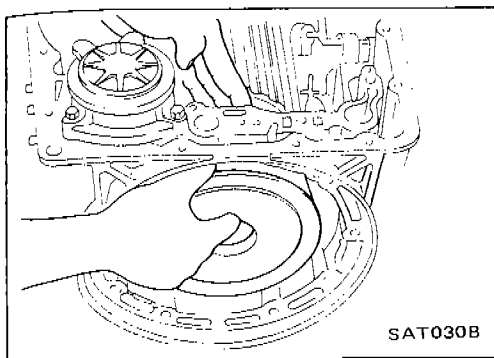

- Remove front bearing race from clutch pack.
- Remove rear bearing race from clutch pack.

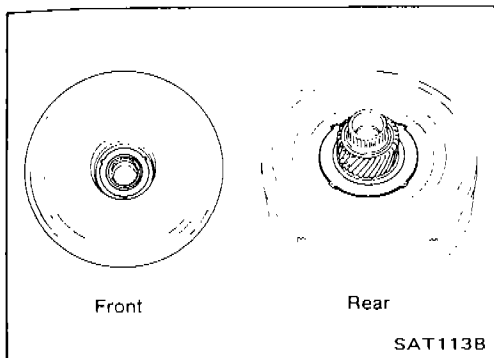

- Remove front planetary carrier from transmission case.

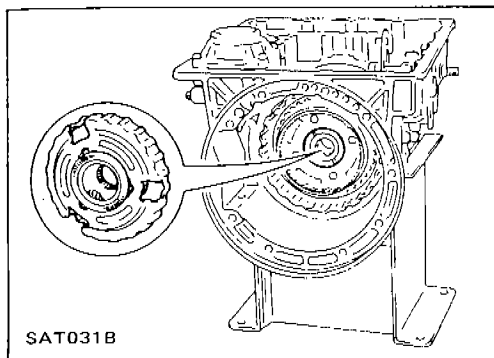

- Remove front needle bearing from front planetary carrier.
- Remove rear bearing from front planetary carrier.

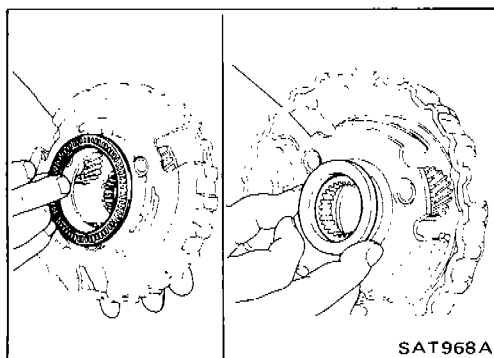

- Remove rear sun gear from transmission case.

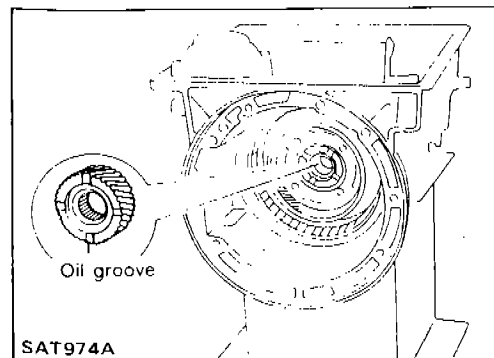

DISASSEMBLY

Disassembly (Cont'd)

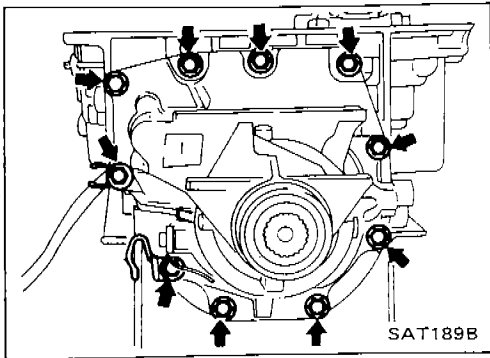

17. Remove rear extension.

- Remove rear extension from transmission case.
- Remove rear extension gasket from transmission case.

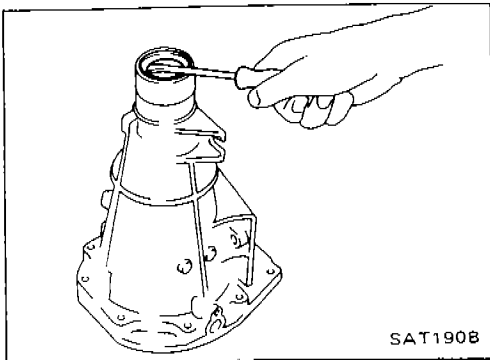

c. Remove oil seal from rear extension.

- Do not remove oil seal unless it is to be replaced.

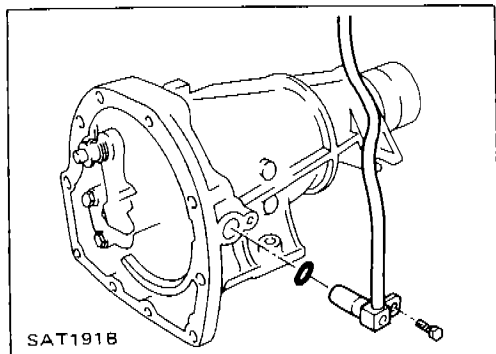

d. Remove revolution sensor from rear extension.

- Remove O-ring from revolution sensor.

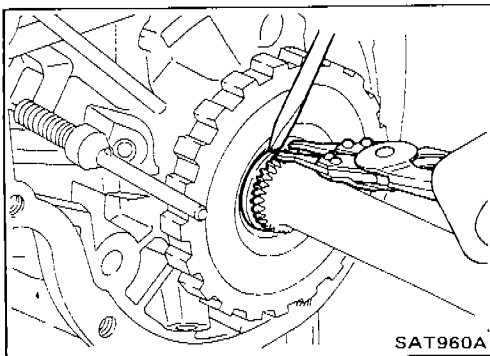

18. Remove output shaft and parking gear.

- Remove rear snap ring from output shaft.

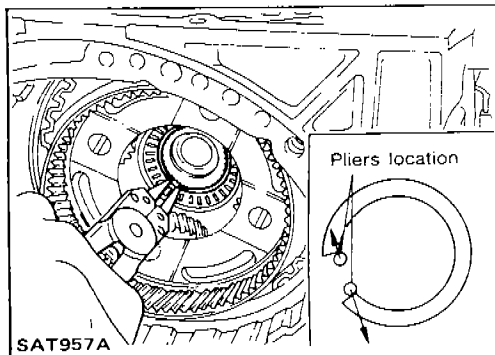

b. Slowly push output shaft all the way forward.

- Do not use excessive force.
- Remove snap ring from output shaft.

DISASSEMBLY

Disassembly (Cont'd)

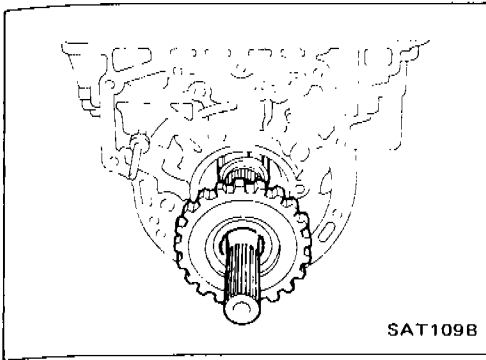

- d. Remove output shaft and parking gear as a unit from transmission case.
- e. Remove parking gear from output shaft.

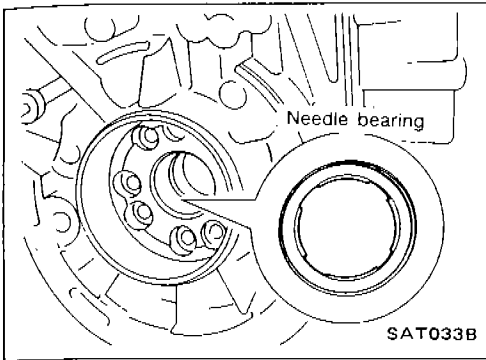

- f. Remove needle bearing from transmission case.

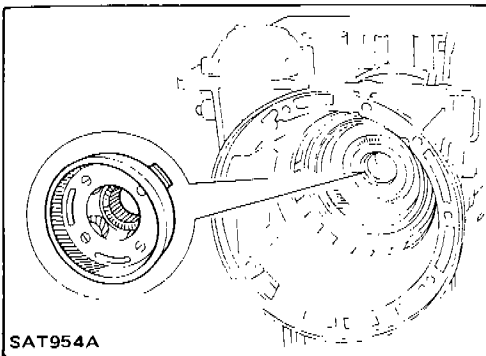

- 19. Remove rear side clutch and gear components.
- a. Remove front internal gear.

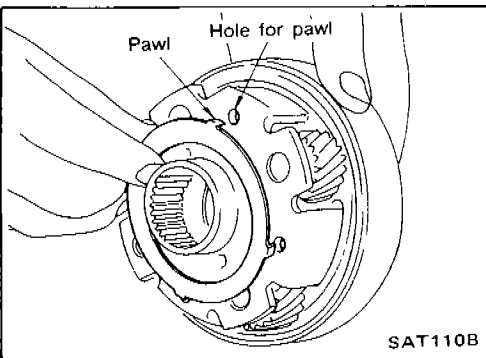

- b. Remove bearing race from front internal gear.

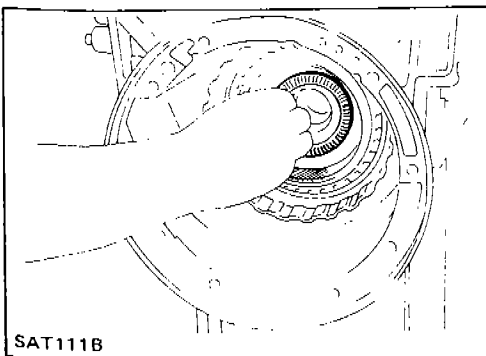

- c. Remove needle bearing from rear internal gear.

DISASSEMBLY

Disassembly (Cont'd)

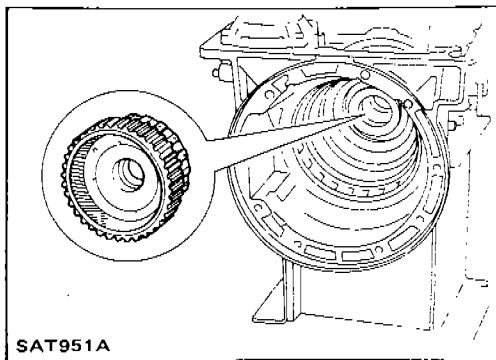

- d. Remove rear internal gear, forward clutch hub and overrun clutch hub as a set from transmission case.

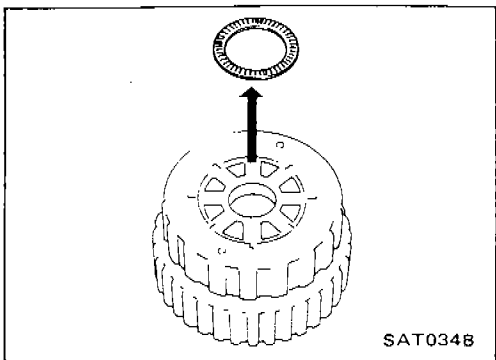

- e. Remove needle bearing from overrun clutch hub.

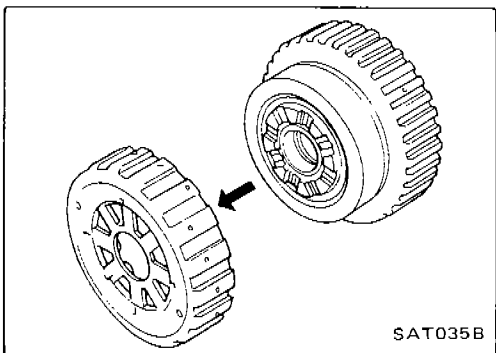

- f. Remove overrun clutch hub from rear internal gear and forward clutch hub.

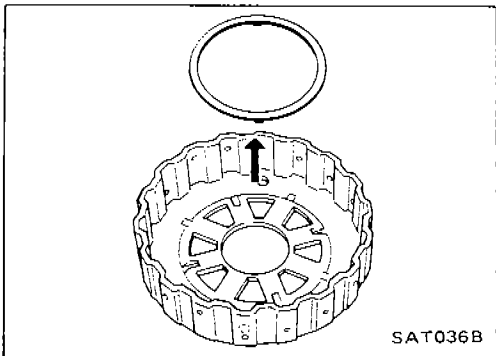

- g. Remove thrust washer from overrun clutch hub.

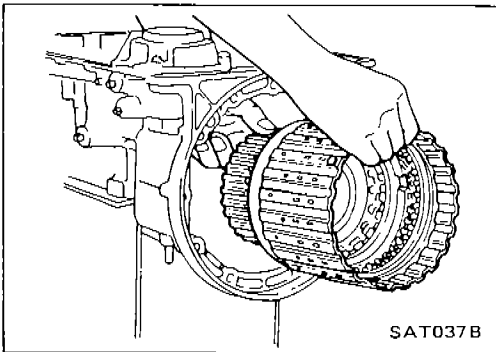

- h. Remove forward clutch assembly from transmission case.

DISASSEMBLY

Disassembly (Cont'd)

20. Remove band servo and accumulator components.
- Remove band servo retainer from transmission case.

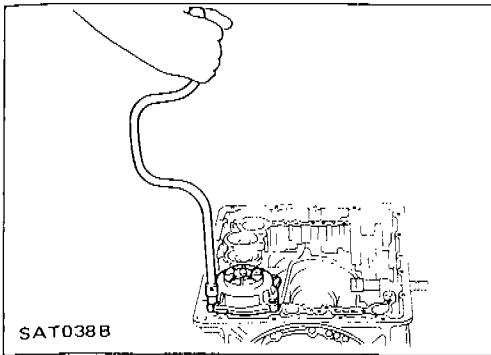

- Apply compressed air to oil hole until band servo piston comes out of transmission case.

- Hold piston with a rag and gradually direct air to oil hole.
- Remove return springs.

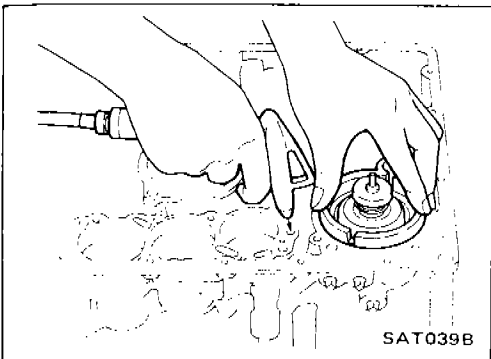

- Remove springs from accumulator pistons B, C and D.
- Apply compressed air to each oil hole until piston comes out.

- Hold piston with a rag and gradually direct air to oil hole.

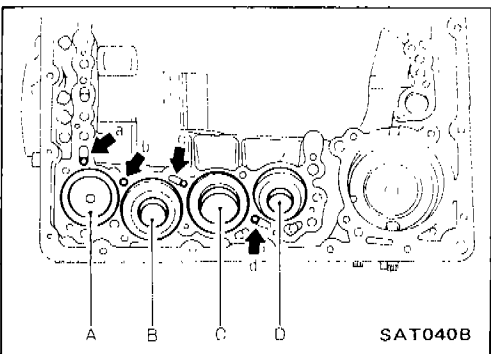

| | | | | |
|---------------------------------------|---|---|---|---|
| Identification of accumulator pistons | A | B | C | D |
| Identification of oil holes | a | b | c | d |

- Remove O-ring from each piston.

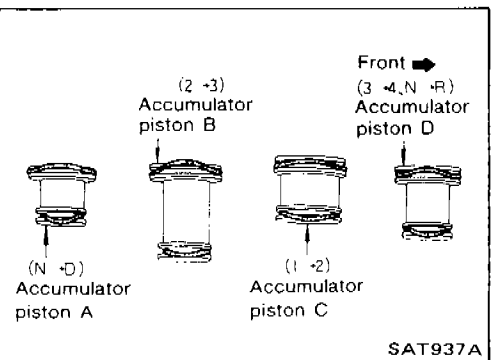

21. Remove manual shaft components, if necessary.

- Hold width across flats of manual shaft (outside the transmission case) and remove lock nut from shaft.

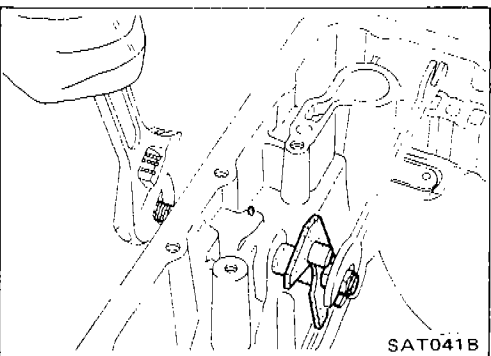

DISASSEMBLY

Disassembly (Cont'd)

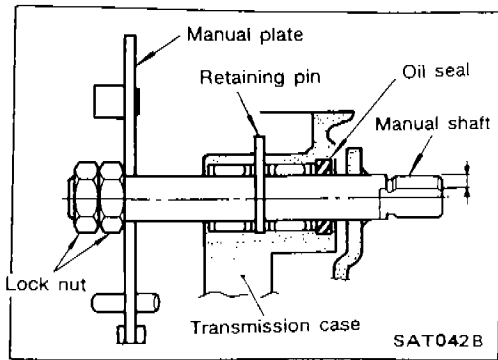

b. Remove retaining pin from transmission case.

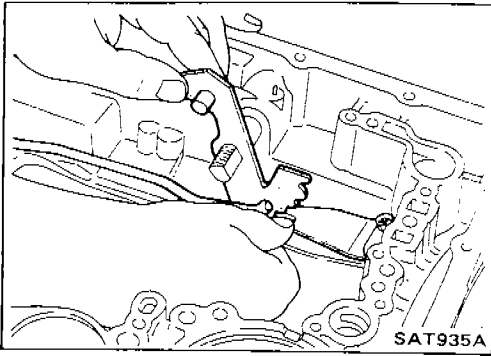

c. While pushing detent spring down, remove manual plate and parking rod from transmission case.

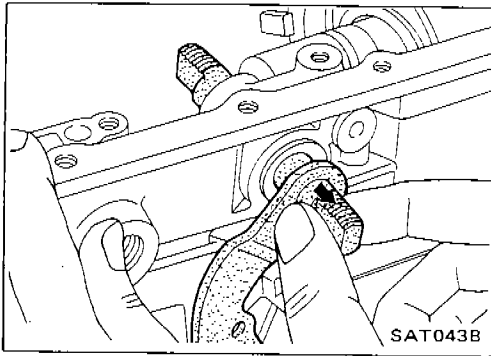

d. Remove manual shaft from transmission case.

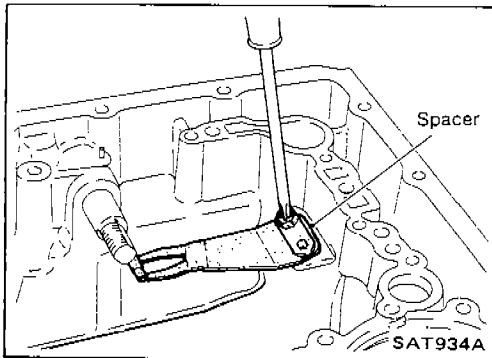

e. Remove spacer and detent spring from transmission case.

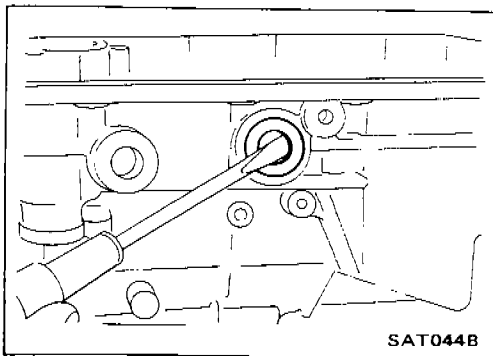

f. Remove oil seal from transmission case.

REPAIR FOR COMPONENT PARTS

Oil Pump

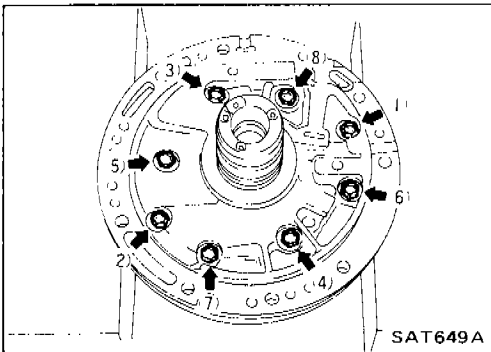
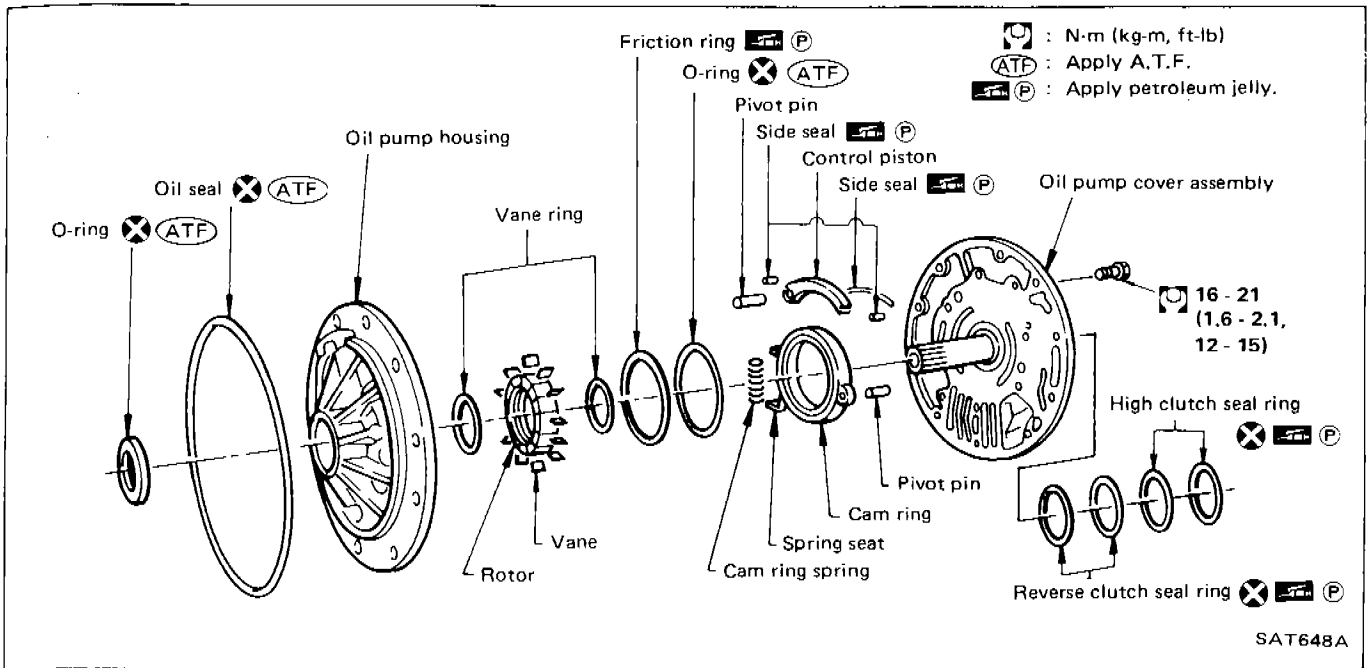

DISASSEMBLY

1. Loosen bolts in numerical order and remove oil pump cover.

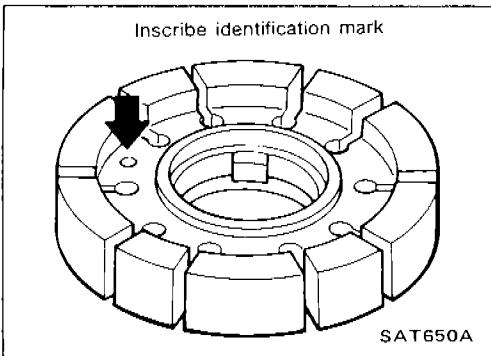

2. Remove rotor, vane rings and vanes.

- Inscribe a mark on back of rotor for identification of fore-aft direction when reassembling rotor. Then remove rotor.

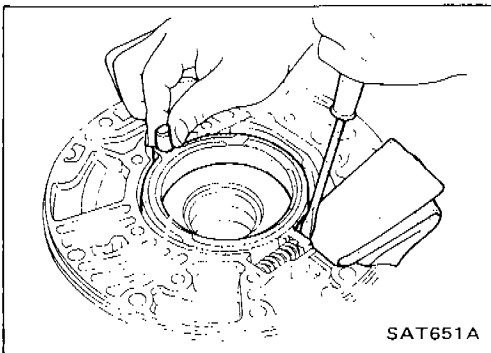

3. While pushing on cam ring remove pivot pin.

- Be careful not to scratch oil pump housing.

REPAIR FOR COMPONENT PARTS

Oil Pump (Cont'd)

4. While holding cam ring and spring lift out cam ring spring.

- Be careful not to damage oil pump housing.
- Hold cam ring spring to prevent it from jumping.

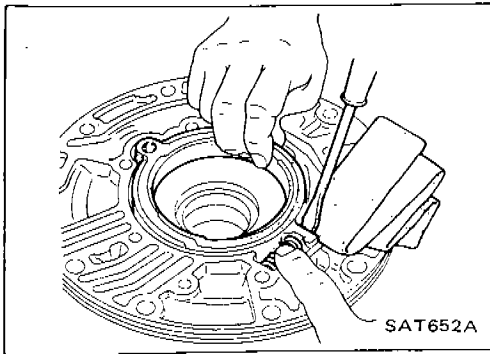

5. Remove cam ring and cam ring spring from oil pump housing.

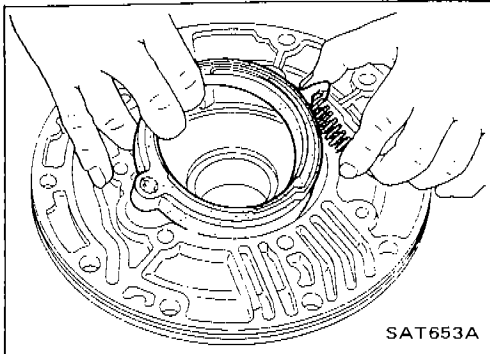

6. Remove pivot pin from control piston and remove control piston assembly.

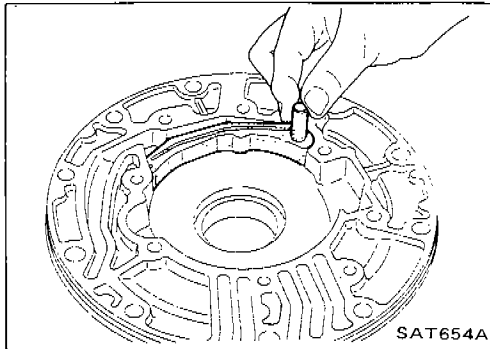

7. Remove oil seal from oil pump housing.

- Be careful not to scratch oil pump housing.

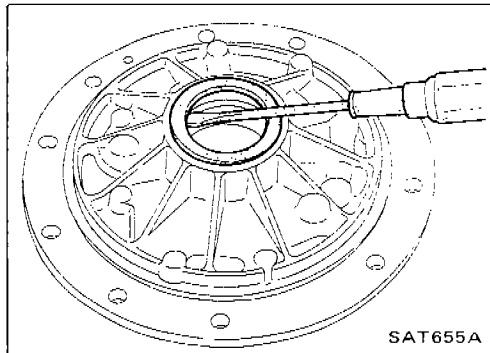

INSPECTION

Oil pump cover, rotor, vanes, control piston, side seals, cam ring and friction ring

- Check for wear or damage.

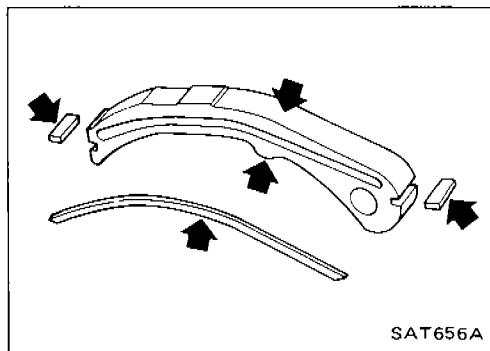

REPAIR FOR COMPONENT PARTS

Oil Pump (Cont'd)

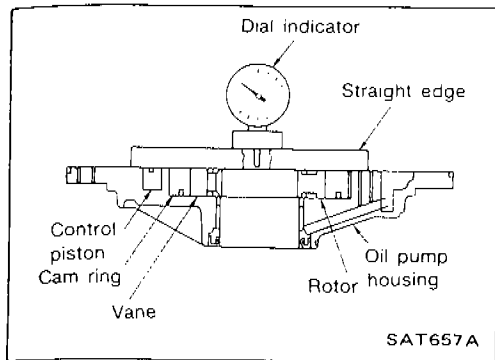

Side clearances

- Measure side clearances between end of oil pump housing and cam ring, rotor, vanes and control piston in at least four places along their circumferences. Maximum measured values should be within specified ranges.
- Before measuring side clearance, check that friction rings, O-ring, control piston side seals and cam ring spring are removed.

Standard clearance:

Cam ring

0.01 - 0.024 mm (0.0004 - 0.0009 in)

Rotor, vanes, control piston

0.03 - 0.044 mm (0.0012 - 0.0017 in)

- If not within standard clearance, replace oil pump assembly except oil pump cover assembly.

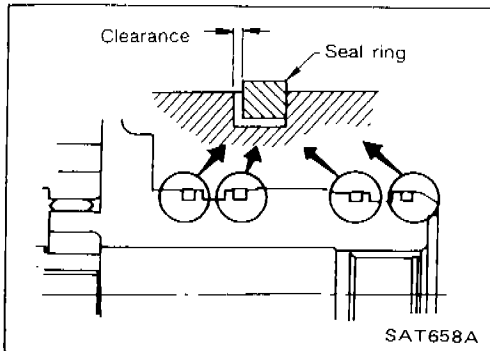

Seal ring clearance

- Measure clearance between seal ring and ring groove.

Standard clearance:

0.10 - 0.25 mm (0.0039 - 0.0098 in)

Wear limit:

0.25 mm (0.0098 in)

- If not within wear limit, replace oil pump cover assembly.

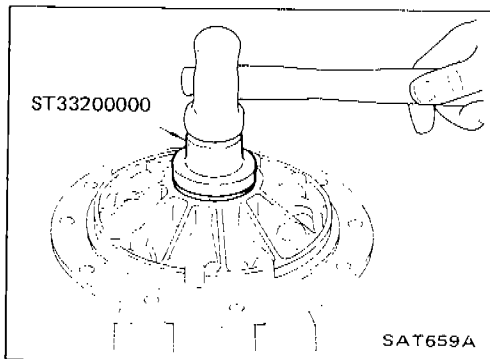

ASSEMBLY

1. Drive oil seal into oil pump housing.

- Apply A.T.F. to outer periphery and lip surface.

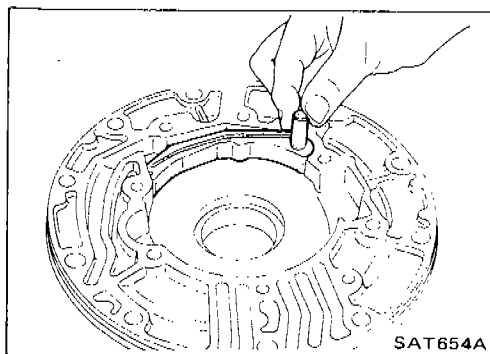

2. Install cam ring in oil pump housing using the following steps.
 - a. Install side seal on control piston.
 - Pay attention to its direction — Black surface goes toward control piston.
 - Apply petroleum jelly to side seal.
 - b. Install control piston on oil pump.

REPAIR FOR COMPONENT PARTS

Oil Pump (Cont'd)

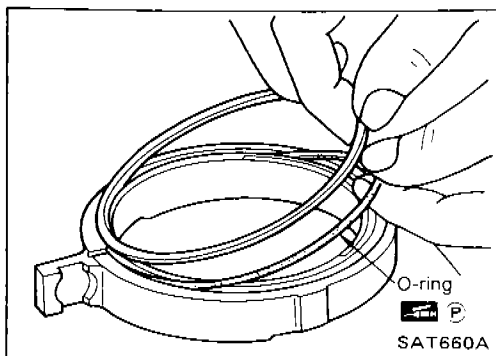

- c. Install O-ring and friction ring on cam ring.
● Apply petroleum jelly to O-ring.

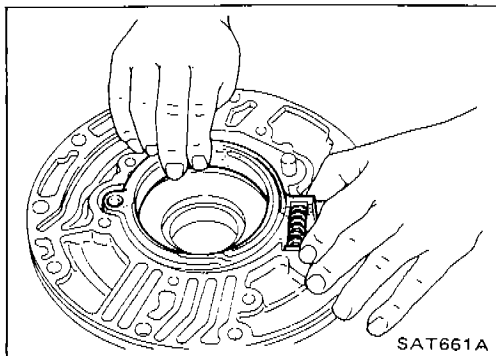

- d. Assemble cam ring, cam ring spring and spring seat. Install spring by pushing it against pump housing.

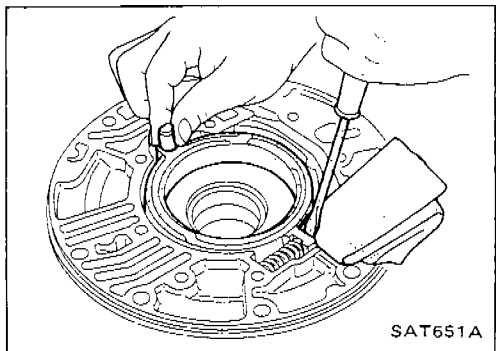

- e. While pushing on cam ring install pivot pin.

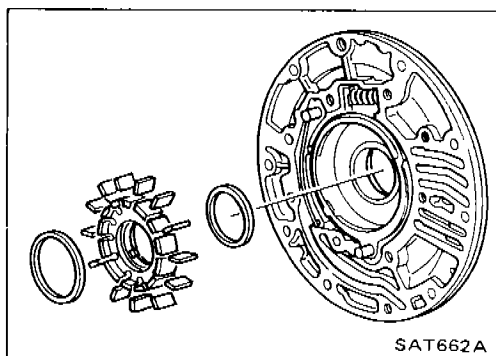

3. Install rotor, vanes and vane rings.
● Pay attention to direction of rotor.

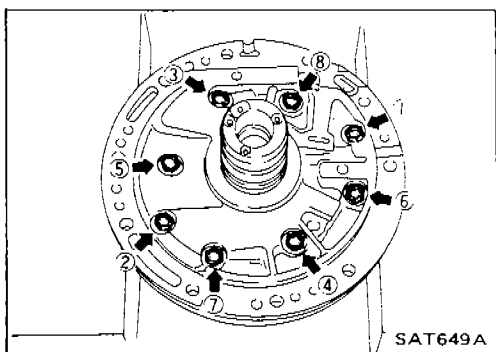

4. Install oil pump housing and oil pump cover.
a. Wrap masking tape around splines of oil pump cover assembly to protect seal. Position oil pump cover assembly in oil pump housing assembly, then remove masking tape.
b. Tighten bolts in a criss-cross pattern.

REPAIR FOR COMPONENT PARTS

Oil Pump (Cont'd)

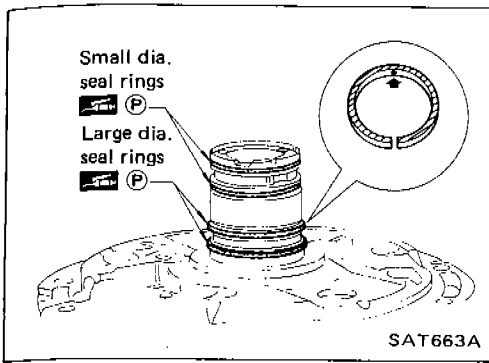

5. Install seal rings carefully after packing ring grooves with petroleum jelly. Press rings down into jelly to a close fit.

- Seal rings come in two different diameters. Check fit carefully in each groove.

Small dia. seal ring:

No mark

Large dia. seal ring:

Yellow mark in area shown by arrow

- Do not spread gap of seal ring excessively while installing. It may deform ring.

REPAIR FOR COMPONENT PARTS

Control Valve Assembly

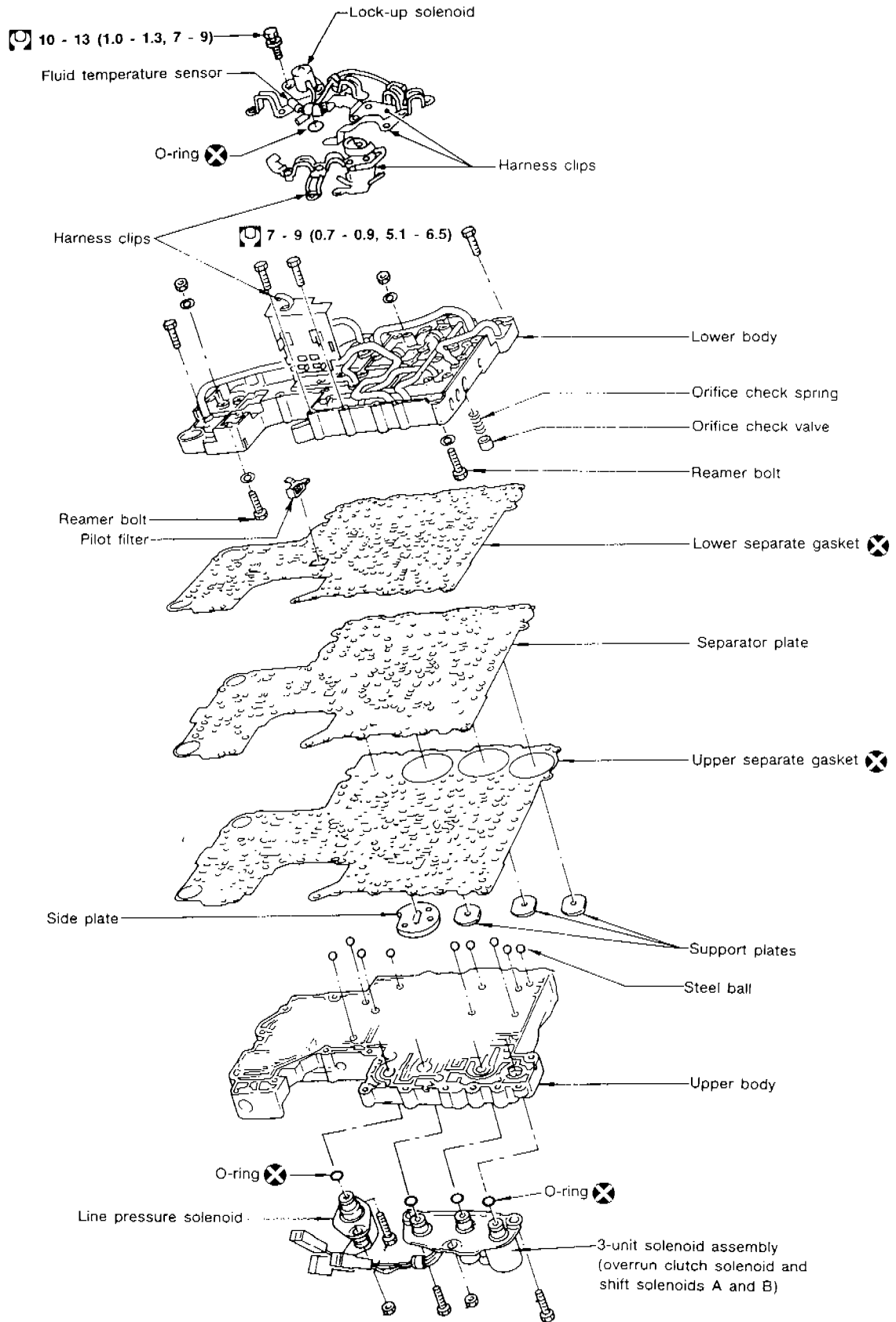

☐ : N·m (kg·m, ft·lb)

SAT193B

AT-96

REPAIR FOR COMPONENT PARTS

Control Valve Assembly (Cont'd)

DISASSEMBLY

1. Remove solenoids.
 - a. Remove lock-up solenoid and side plate from lower body.
 - b. Remove O-ring from solenoid.

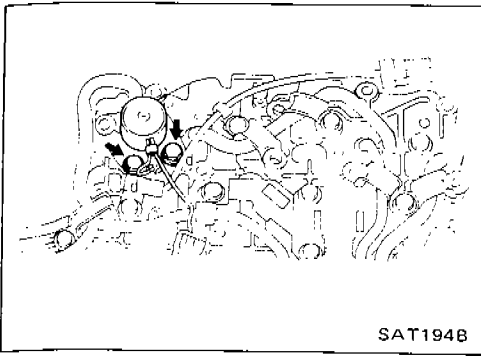

- c. Remove line pressure solenoid from upper body.
 - d. Remove O-ring from solenoid.

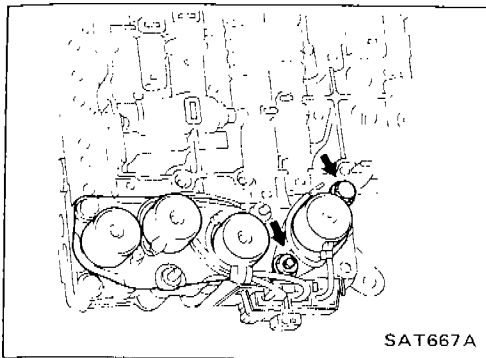

- e. Remove 3-unit solenoid assembly from upper body.
 - f. Remove O-rings from solenoids.

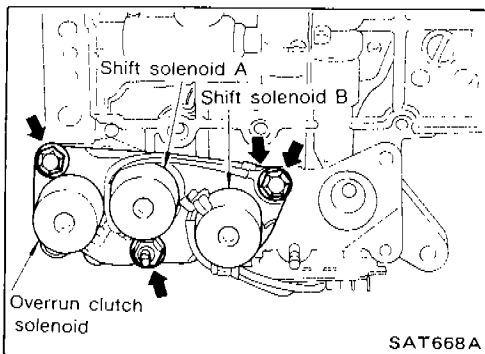

2. Disassemble upper and lower bodies.
 - a. Place upper body facedown, and remove bolts, reamer bolts and support plates.
 - b. Remove lower body, separator plate and separate gasket as a unit from upper body.
 - **Be careful not to drop pilot filter, orifice check valve, spring and steel balls.**

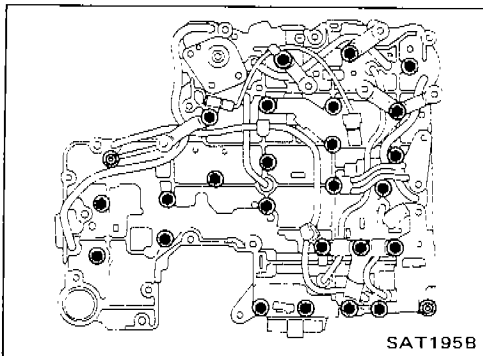

- c. Place lower body facedown, and remove separate gasket and separator plate.
 - d. Remove pilot filter, orifice check valve and orifice check spring.

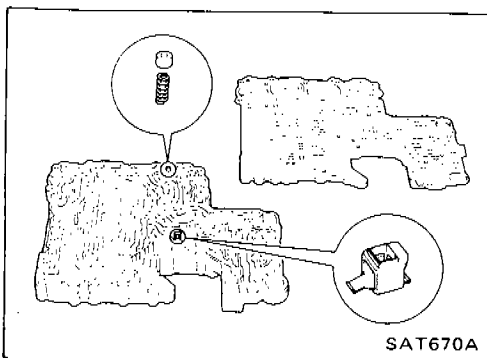

REPAIR FOR COMPONENT PARTS

Control Valve Assembly (Cont'd)

- e. Check to see that steel balls are properly positioned in upper body and then remove them from upper body.

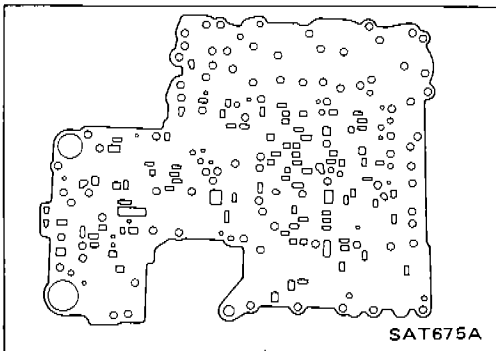
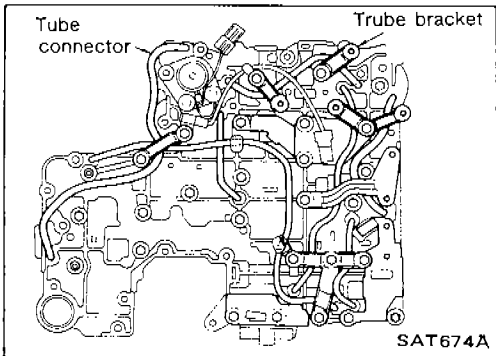
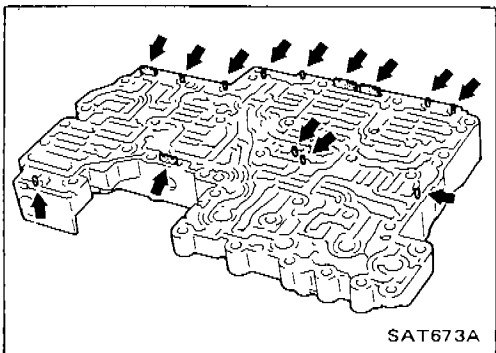
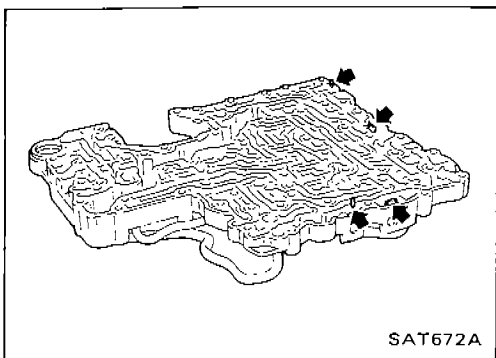
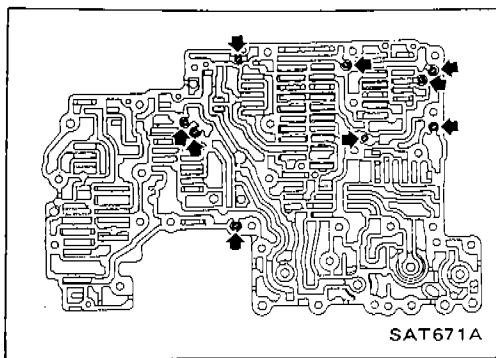

INSPECTION

Lower and upper bodies

- Check to see that there are pins and retainer plates in lower body.

- Check to see that there are pins and retainer plates in upper body.

- **Be careful not to lose these parts.**

- Check to make sure that oil circuits are clean and free from damage.

- Check tube brackets and tube connectors for damage.

Separator plates

- Check to make sure that separator plate is free of damage and not deformed and oil holes are clean.

REPAIR FOR COMPONENT PARTS

Control Valve Assembly (Cont'd)

Pilot filter

- Check to make sure that filter is not clogged or damaged.

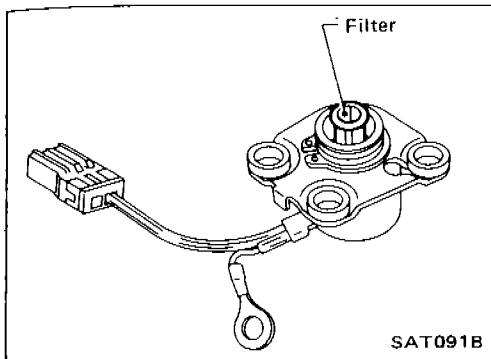
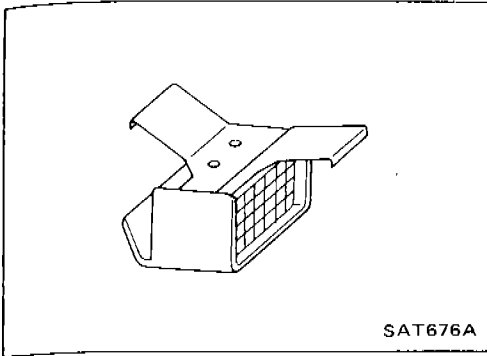

Lock-up solenoid

- Check that filter is not clogged or damaged.
- Measure resistance. — Refer to "Electrical Components Inspection".

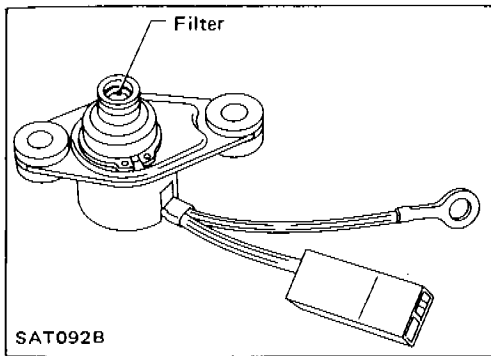

Line pressure solenoid

- Check that filter is not clogged or damaged.
- Measure resistance. — Refer to "Electrical Components Inspection".

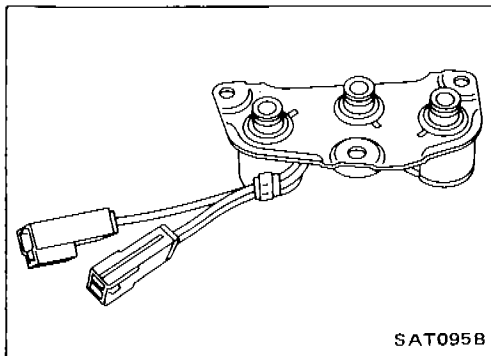

3-unit solenoid assembly (Overrun clutch solenoid and shift solenoids A and B)

- Measure resistance of each solenoid. — Refer to "Electrical Components Inspection".

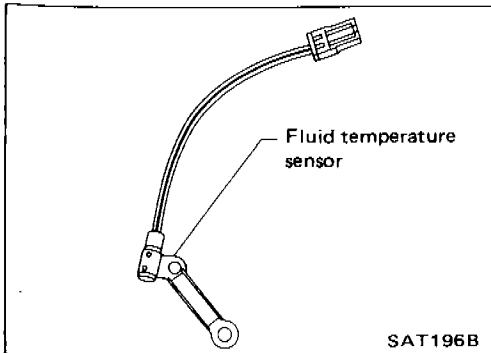

Fluid temperature sensor

- Measure resistance. — Refer to "Electrical Components Inspection".

REPAIR FOR COMPONENT PARTS

Control Valve Assembly (Cont'd) ASSEMBLY

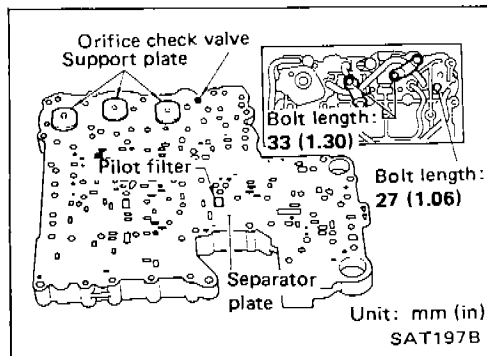
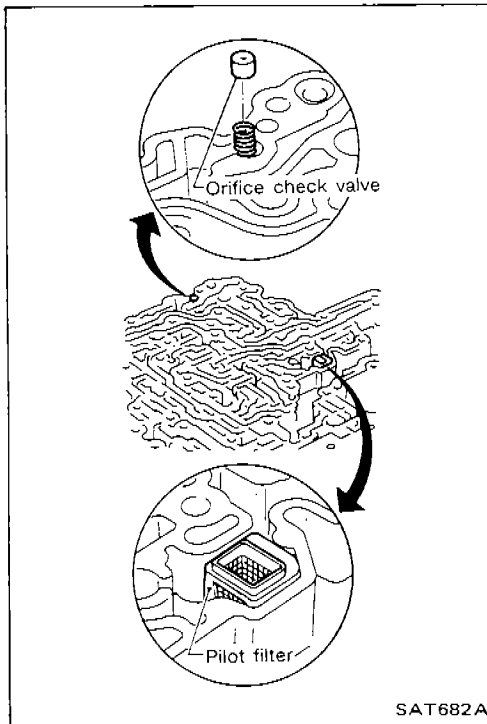
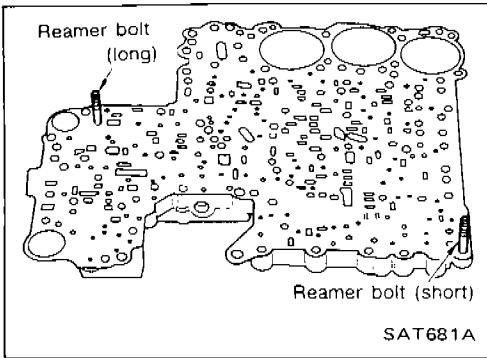
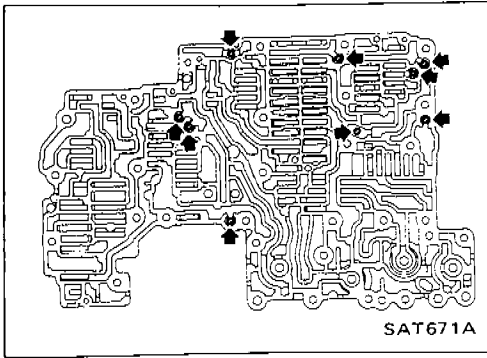

1. Install upper and lower bodies.
 - a. Place oil circuit of upper body face up. Install steel balls in their proper positions.
 - b. Install reamer bolts from bottom of upper body and install separate gaskets.
 - c. Place oil circuit of lower body face up. Install orifice check spring, orifice check valve and pilot filter.
 - d. Install lower separate gaskets and separator plates on lower body.
 - e. Install and temporarily tighten support plates, fluid temperature sensor and tube brackets.

REPAIR FOR COMPONENT PARTS

Control Valve Assembly (Cont'd)

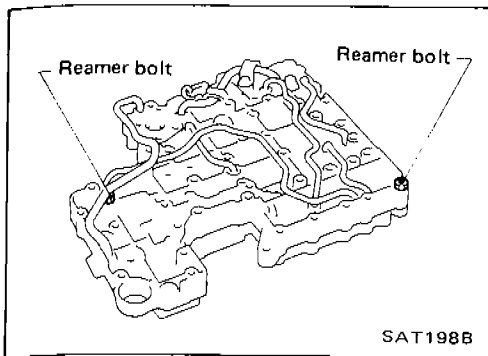

f. Temporarily assemble lower and upper bodies, using reamer bolt as a guide.

- Be careful not to dislocate or drop steel balls, orifice check spring, orifice check valve and pilot filter.

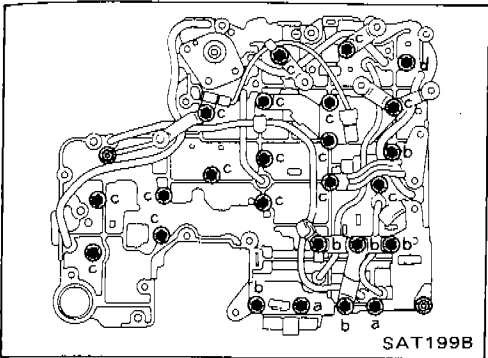

g. Install and temporarily tighten bolts and tube brackets in their proper locations.

Bolt length and location:

| Item | Bolt symbol | a | b | c | d |
|------|-------------|---------|--------------|--------------|--------------|
| | Bolt length | mm (in) | 70 (2.76) | 50 (1.97) | 33 (1.30) |

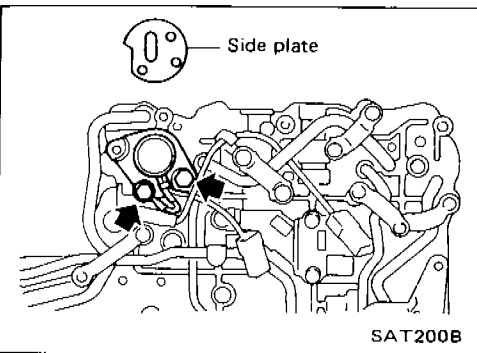

2. Install solenoids.

a. Attach O-ring and install lock-up solenoid and side plates onto lower body.

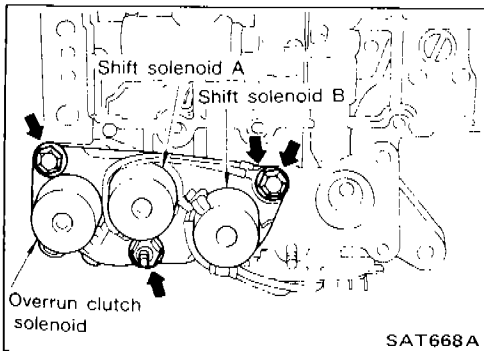

b. Attach O-rings and install 3-unit solenoids assembly onto upper body.

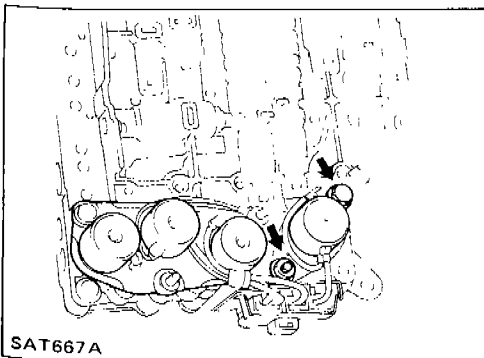

c. Attach O-ring and install line pressure solenoid onto upper body.

3. Tighten all bolts.

Control Valve Upper Body

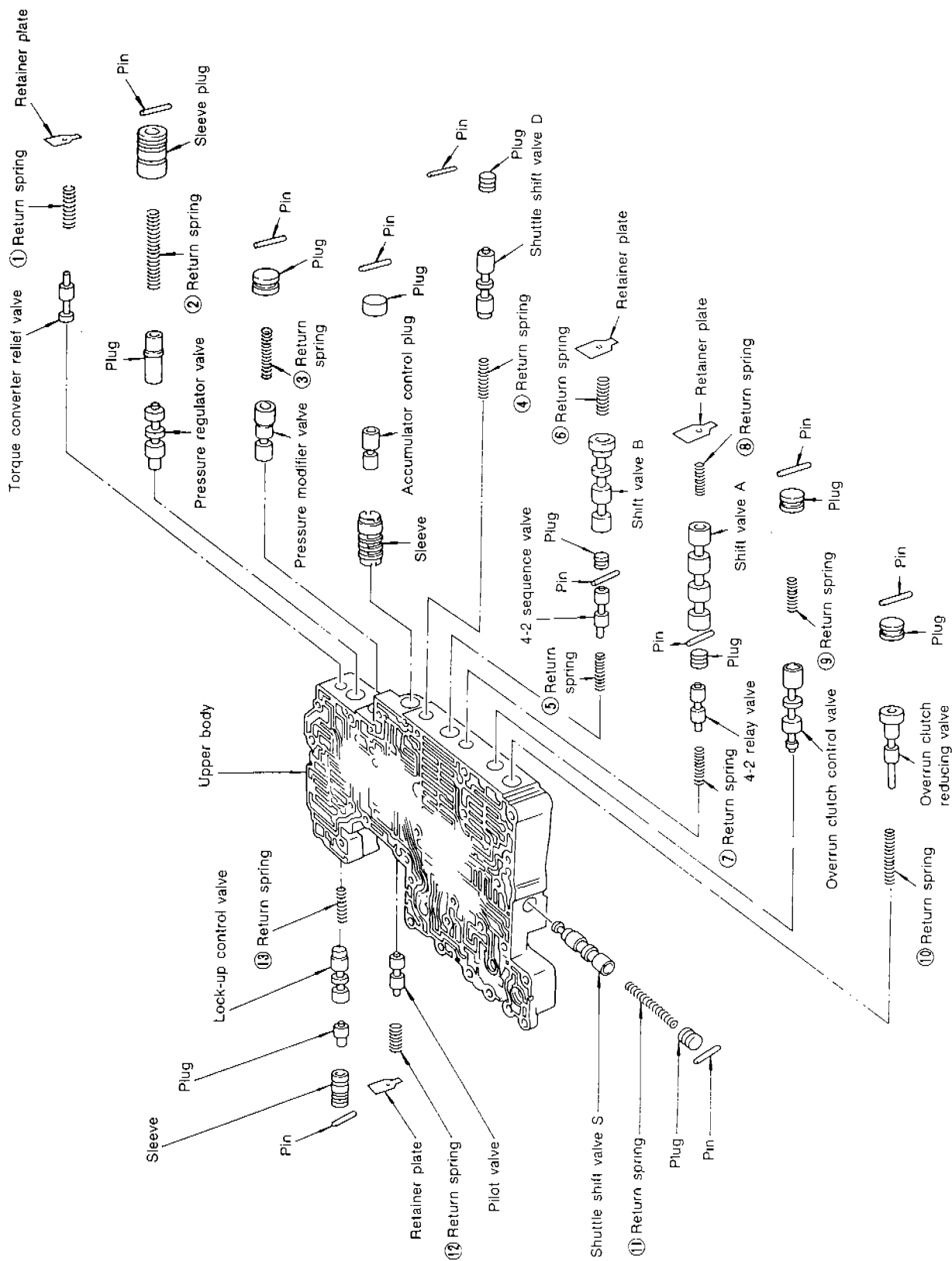

Numbers preceding valve springs correspond with those shown in Spring Chart on page AT-105.

Apply A.T.F. to all components before their installation.

REPAIR FOR COMPONENT PARTS

Control Valve Upper Body (Cont'd)

DISASSEMBLY

1. Remove valves at parallel pins.
 - Do not use a magnetic hand.

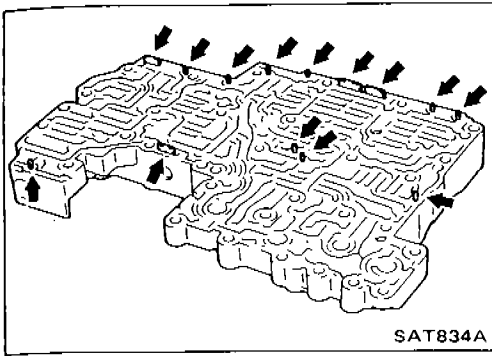

- a. Use a wire paper clip to push out parallel pins.

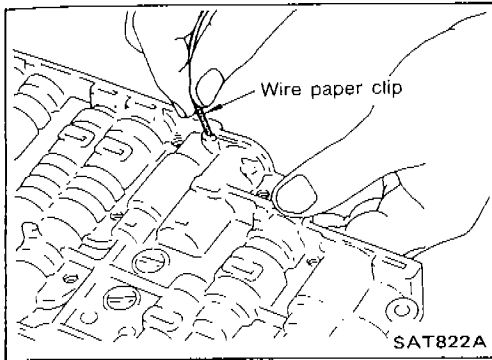

- b. Remove parallel pins while pressing their corresponding plugs and sleeves.

- Remove plug slowly to prevent internal parts from jumping out.

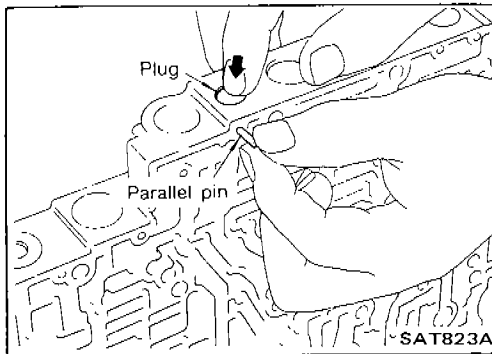

- c. Place mating surface of valve facedown, and remove internal parts.

- If a valve is hard to remove, place valve body facedown and lightly tap it with a soft hammer.
- Be careful not to drop or damage valves and sleeves.

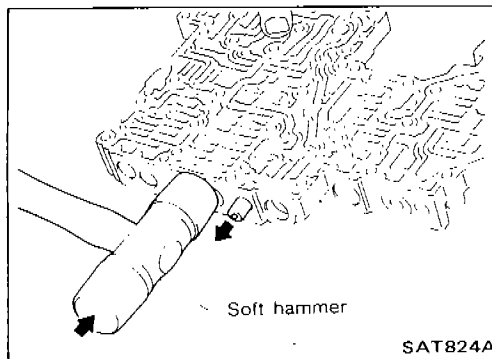

2. Remove valves at retainer plates.

- a. Pry out retainer plate with wire paper clip.

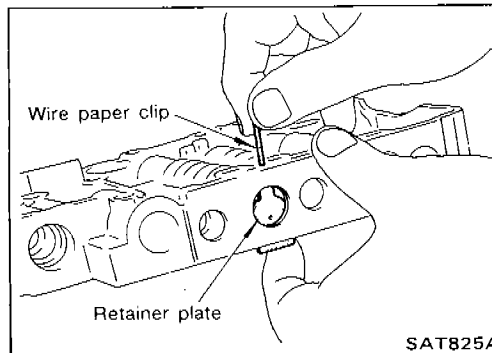

REPAIR FOR COMPONENT PARTS

Control Valve Upper Body (Cont'd)

b. Remove retainer plates while holding spring.

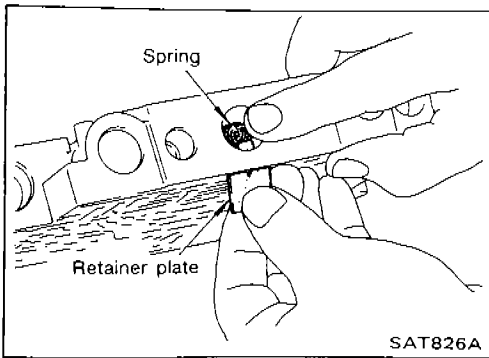

c. Place mating surface of valve facedown, and remove internal parts.

- If a valve is hard to remove, lightly tap valve body with a soft hammer.

- Be careful not to drop or damage valves, sleeves, etc.

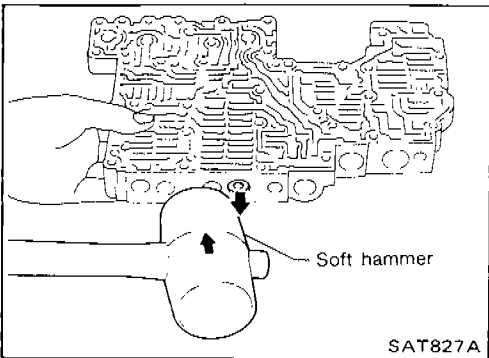

- 4-2 sequence valve and relay valve are located far back in upper body. If they are hard to remove, carefully push them out using stiff wire.

- Be careful not to scratch sliding surface of valve with wire.

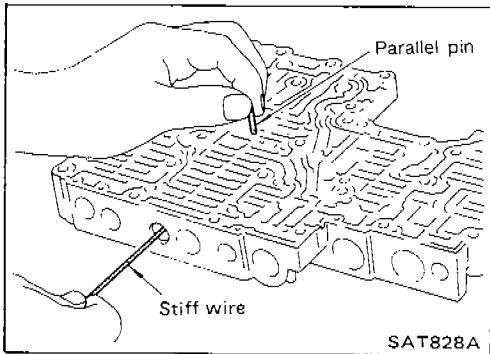

REPAIR FOR COMPONENT PARTS

Control Valve Upper Body (Cont'd)

INSPECTION

Valve springs

- Measure free length and outer diameter of each valve spring. Also check for damage or deformation.
- Numbers of each valve spring listed in table below are the same as those in the figure on AT-102.

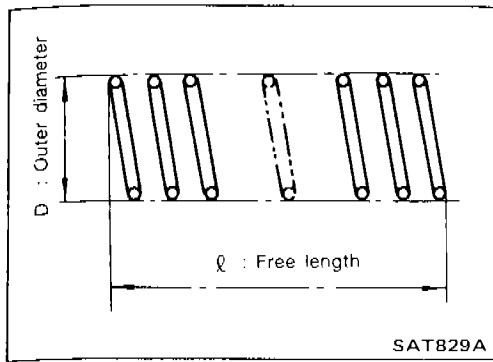

Inspection standard

Unit: mm (in)

| Parts | Item | Part No. | ℓ | D |
|-------|--------------------------------------|-------------|----------------|---------------|
| ① | Torque converter relief valve spring | 31742-41X18 | 32.3 (1.272) | 9.0 (0.354) |
| ② | Pressure regulator valve spring | 31742-41X16 | 61.5 (2.421) | 8.9 (0.350) |
| ③ | Pressure modifier valve spring | 31742-41X19 | 31.95 (1.2579) | 6.8 (0.268) |
| ④ | Shuttle shift valve D spring | 31762-41X00 | 26.5 (1.043) | 6.0 (0.236) |
| ⑤ | 4-2 sequence valve spring | 31756-41X00 | 29.1 (1.146) | 6.95 (0.2736) |
| ⑥ | Shift valve B spring | 31762-41X01 | 25.0 (0.984) | 7.0 (0.276) |
| ⑦ | 4-2 relay valve spring | 31756-41X00 | 29.1 (1.146) | 6.95 (0.2736) |
| ⑧ | Shift valve A spring | 31762-41X01 | 25.0 (0.984) | 7.0 (0.276) |
| ⑨ | Overrun clutch control valve spring | 31762-41X03 | 23.6 (0.929) | 7.0 (0.276) |
| ⑩ | Overrun clutch reducing valve spring | 31742-41X14 | 38.9 (1.531) | 7.0 (0.276) |
| ⑪ | Shuttle shift valve S spring | 31762-41X04 | 51.0 (2.008) | 5.65 (0.2224) |
| ⑫ | Pilot valve spring | 31742-41X13 | 25.7 (1.012) | 9.1 (0.358) |
| ⑬ | Lock-up control valve spring | 31742-41X22 | 18.5 (0.728) | 13.0 (0.512) |

- Replace valve springs if deformed or fatigued.

Control valves

- Check sliding surfaces of valves, sleeves and plugs.

REPAIR FOR COMPONENT PARTS

Control Valve Upper Body (Cont'd) ASSEMBLY

1. Lubricate the control valve body and all valves with A.T.F. Install control valves by sliding them carefully into their bores.

- Be careful not to scratch or damage valve body.

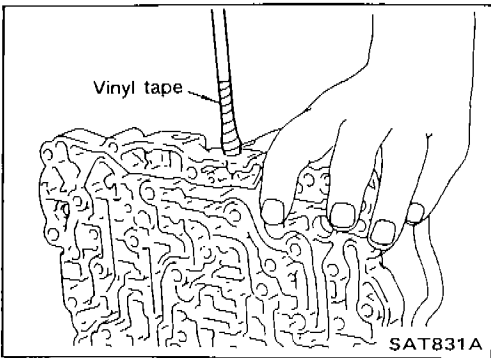
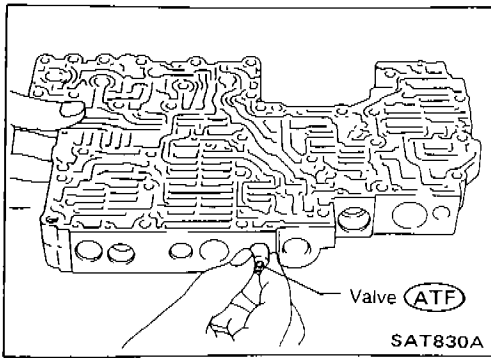

- Wrap a small screwdriver with vinyl tape and use it to insert the valves into proper position.

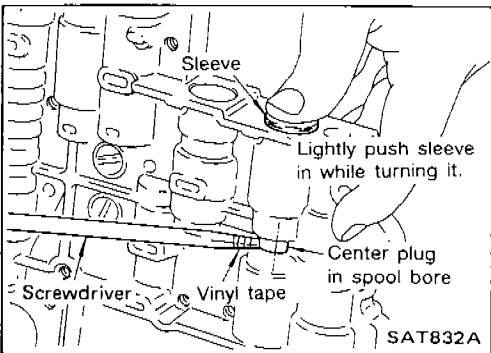

Pressure regulator valve

- If pressure regulator plug is not centered properly, sleeve cannot be inserted into bore in upper body. If this happens, use vinyl tape wrapped screwdriver to center sleeve until it can be inserted.
- Turn sleeve slightly while installing.

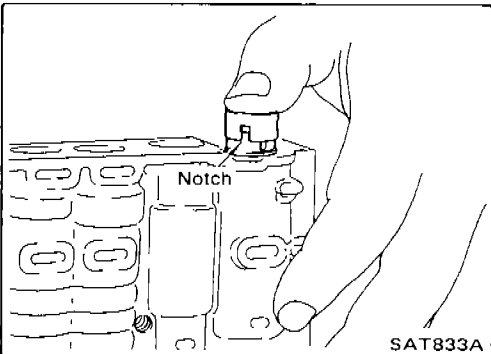

Accumulator control plug

- Align protrusion of accumulator control sleeve with notch in plug.
- Align parallel pin groove in plug with parallel pin, and install accumulator control valve.

2. Install parallel pins and retainer plates.

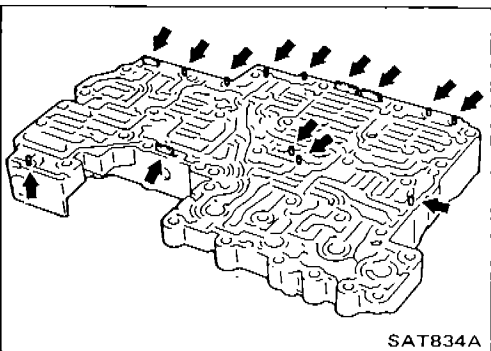

REPAIR FOR COMPONENT PARTS

Control Valve Upper Body (Cont'd)

- While pushing plug, install parallel pin.

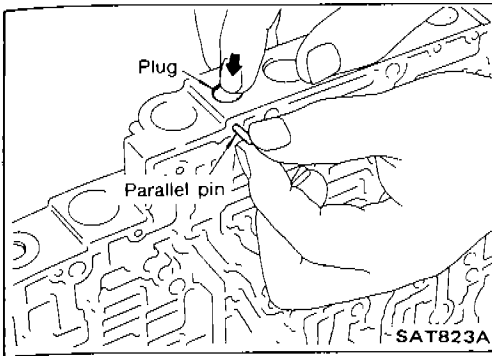

4-2 sequence valve and relay valve

- Push 4-2 sequence valve and relay valve with wire wrapped in vinyl tape to prevent scratching valve body. Install parallel pins.

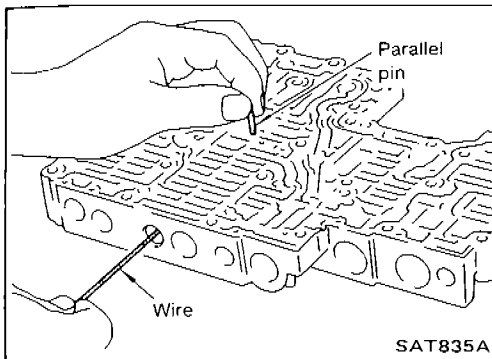

- Insert retainer plate while pushing spring.

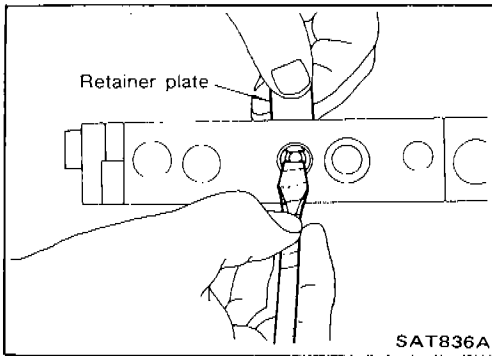

Control Valve Lower Body

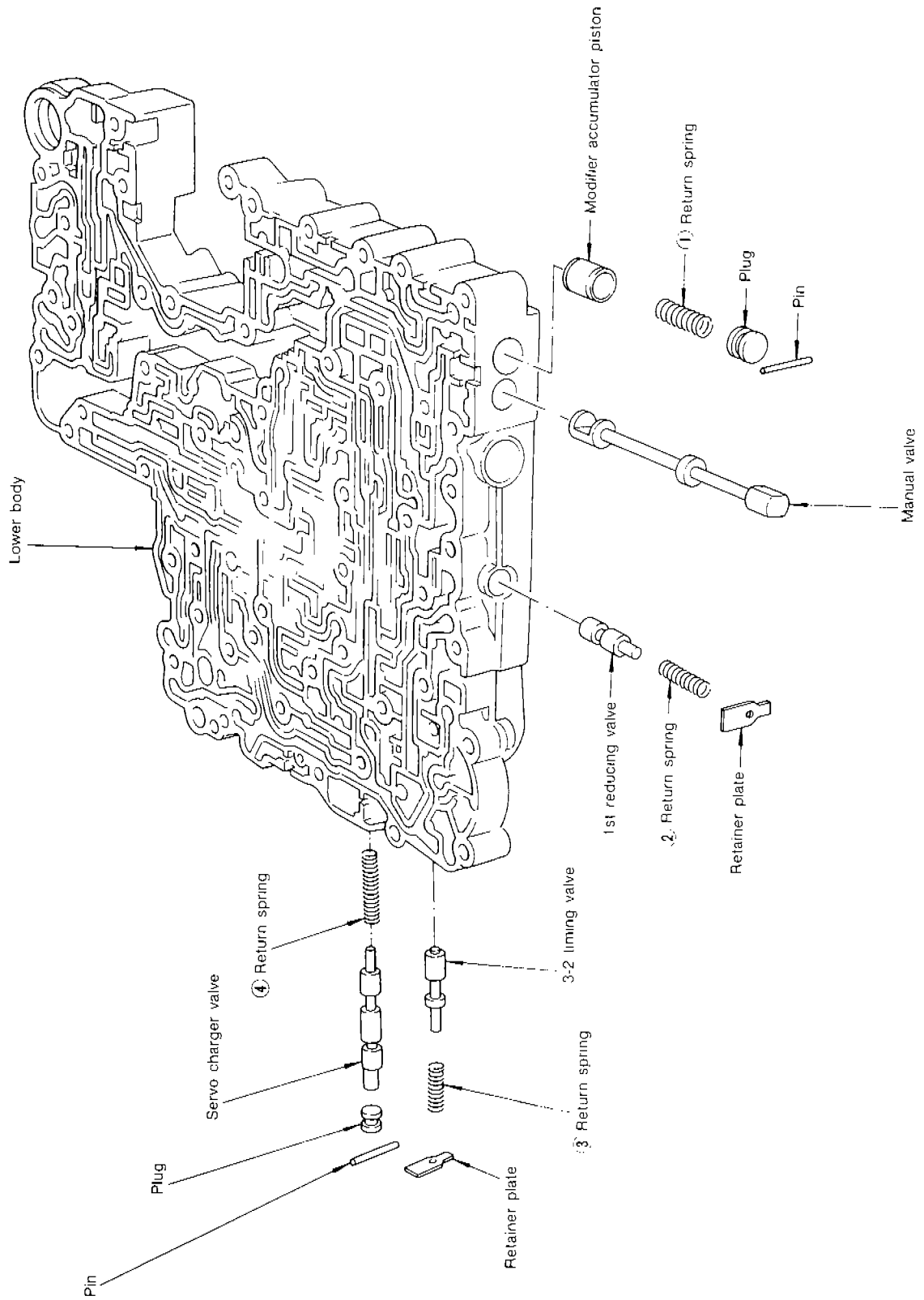

Numbers preceding valve springs correspond with those shown in Spring Chart on page AT-109.

Apply A.T.F. to all components before their installation.

REPAIR FOR COMPONENT PARTS

Control Valve Lower Body (Cont'd)

DISASSEMBLY

1. Remove valves at parallel pins.
 2. Remove valves at retainer plates.
- For removal procedures, refer to "DISASSEMBLY" of Control Valve Upper Body.

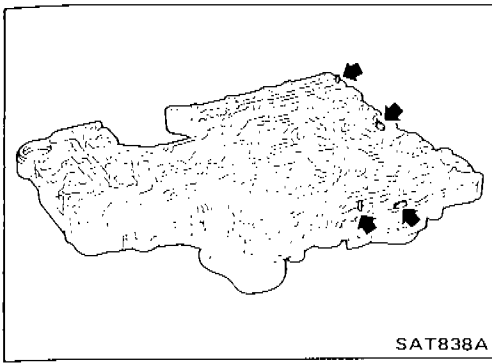

SAT838A

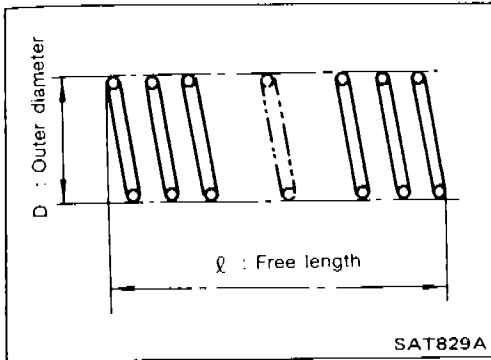

SAT829A

INSPECTION

Valve springs

- Check each valve spring for damage or deformation. Also measure free length and outer diameter.
- Numbers of each valve spring listed in table below are the same as those in the figure on AT-108.

Inspection standard:

Unit: mm (in)

| Parts | Item | Part No. | l | D |
|-------|------------------------------------|-------------|----------------|---------------|
| ① | Modifier accumulator piston spring | 31742-41X15 | 30.5 (1.201) | 9.8 (0.386) |
| ② | 1st reducing valve spring | 31756-41X05 | 25.4 (1.000) | 6.75 (0.2657) |
| ③ | 3-2 timing valve spring | 31742-41X08 | 20.55 (0.8091) | 6.75 (0.2657) |
| ④ | Servo charger valve spring | 31742-41X06 | 23.0 (0.906) | 6.7 (0.264) |

- Replace valve springs if deformed or fatigued.

Control valves

- Check sliding surfaces of control valves, sleeves and plugs for damage.

ASSEMBLY

- Install control valves.
- For installation procedures, refer to "ASSEMBLY" of Control Valve Upper Body.

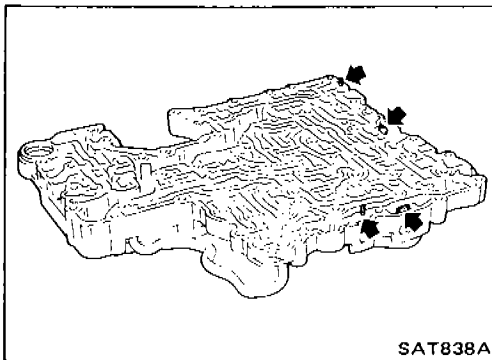

SAT838A

Reverse Clutch

For the number of clutch sheets (drive plate and driven plate), refer to the below cross-section.

(ATF) : Apply A.T.F.
 ★ : Select with proper thickness.

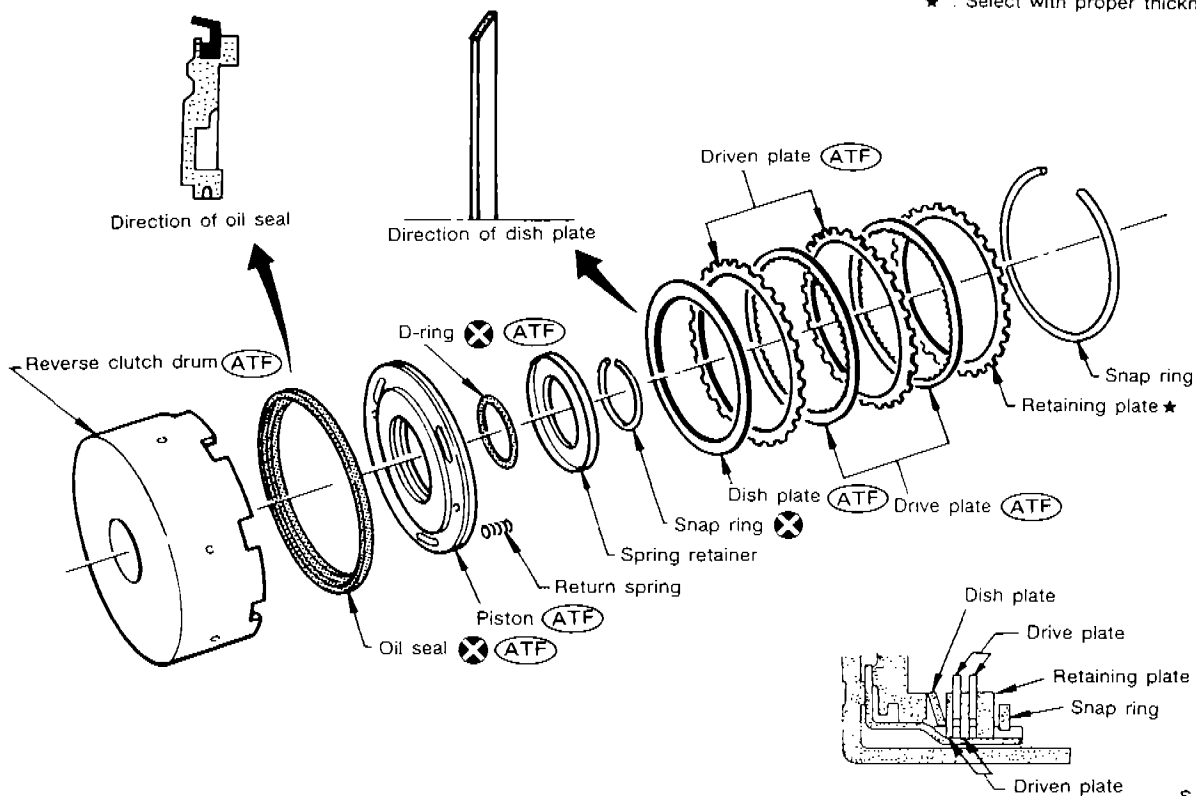

SAT912B

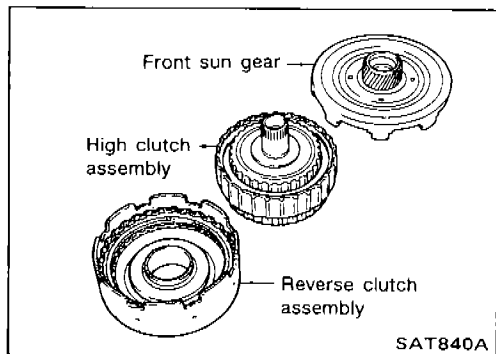

SAT840A

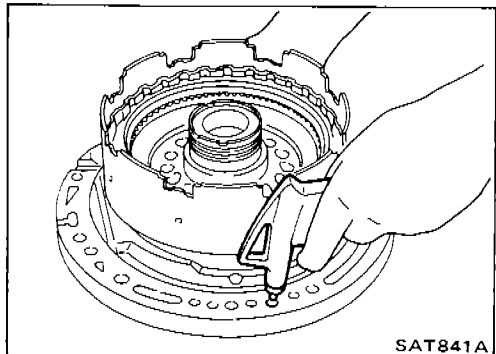

SAT841A

DISASSEMBLY

1. Remove reverse clutch assembly from clutch pack.
2. Check operation of reverse clutch.
 - a. Install seal ring onto oil pump cover and install reverse clutch. Apply compressed air to oil hole.
 - b. Check to see that retaining plate moves to snap ring.
 - c. If retaining plate does not move to snap ring, D-ring or oil seal may be damaged or fluid may be leaking at piston check ball.

REPAIR FOR COMPONENT PARTS

Reverse Clutch (Cont'd)

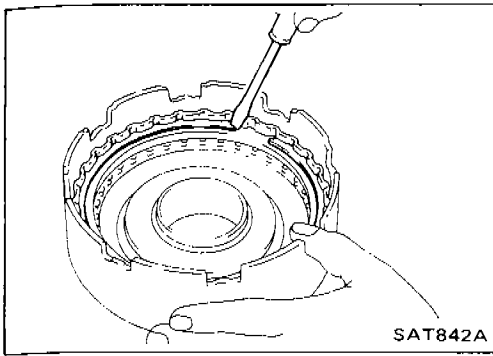

- Remove drive plates, driven plates, retaining plate, dish plate and snap ring.

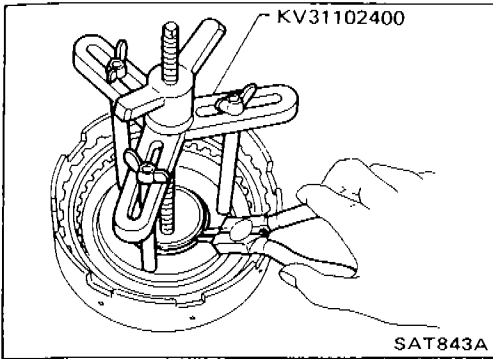

- Remove snap ring from clutch drum while compressing clutch springs.
 - Do not expand snap ring excessively.
- Remove spring retainer and return spring.

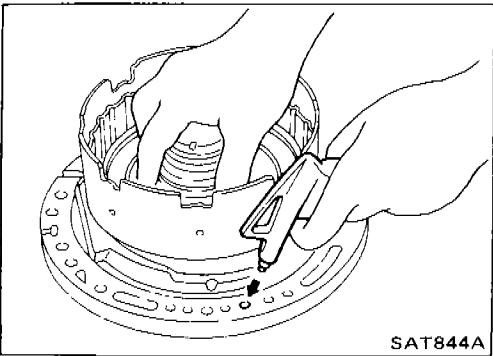

- Install seal ring onto oil pump cover and install reverse clutch drum. While holding piston, gradually apply compressed air to oil hole until piston is removed.
 - Do not apply compressed air abruptly.
- Remove D-ring and oil seal from piston.

INSPECTION

Reverse clutch snap ring and spring retainer

- Check for deformation, fatigue or damage.

Reverse clutch return springs

- Check for deformation or damage. Also measure free length and outside diameter.

Inspection standard:

Unit: mm (in)

| Parts | Part No. | ℓ | D |
|--------|-------------|----------------|--------------|
| Spring | 30505-41X02 | 19.69 (0.7752) | 11.6 (0.457) |

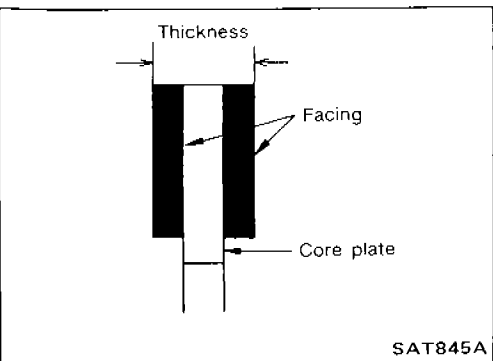
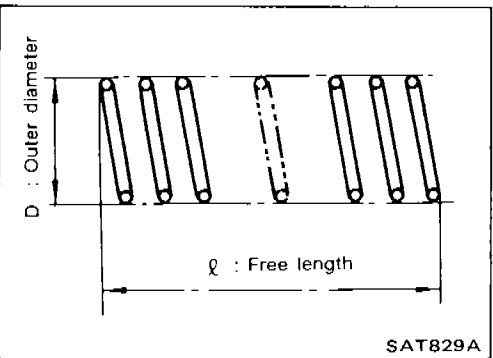

Reverse clutch drive plates

- Check facing for burns, cracks or damage.
- Measure thickness of facing.

Thickness of drive plate:

Standard value 2.0 mm (0.079 in)

Wear limit 1.8 mm (0.071 in)

- If not within wear limit, replace.

Reverse clutch dish plate

- Check for deformation or damage.

REPAIR FOR COMPONENT PARTS

Reverse Clutch (Cont'd)

Reverse clutch piston

- Shake piston to assure that balls are not seized.
- Apply compressed air to check ball oil hole opposite the return spring to assure that there is no air leakage.
- Also apply compressed air to oil hole on return spring side to assure that air leaks past ball.

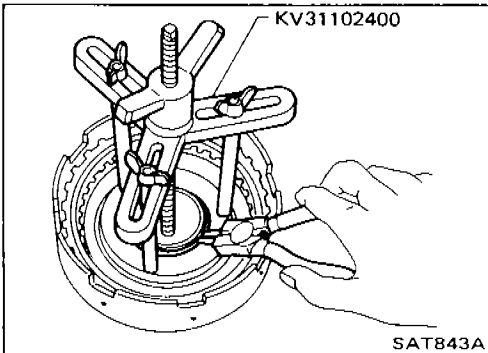
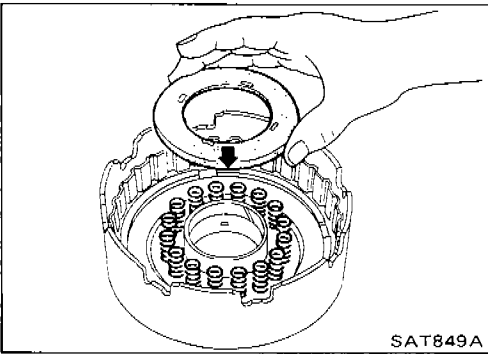
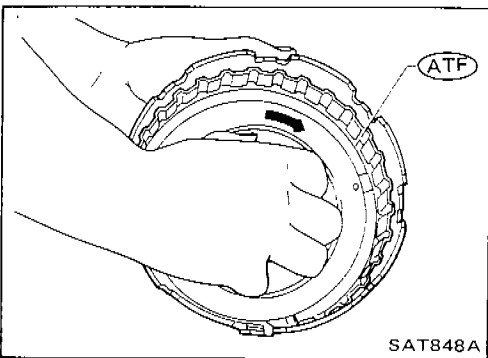
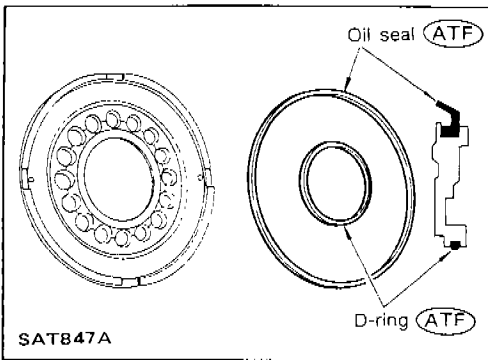
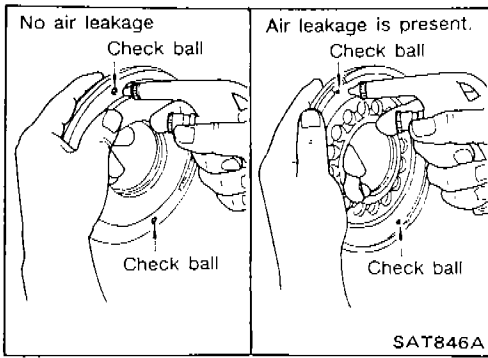

ASSEMBLY

1. Install D-ring and oil seal on piston.
 - **Apply A.T.F. to both parts.**
2. Install piston assembly by turning it slowly and evenly.
 - **Apply A.T.F. to inner surface of drum.**
3. Install return springs and spring retainer.
4. Install snap ring while compressing clutch springs.

REPAIR FOR COMPONENT PARTS

Reverse Clutch (Cont'd)

- Do not align snap ring gap with spring retainer stopper.

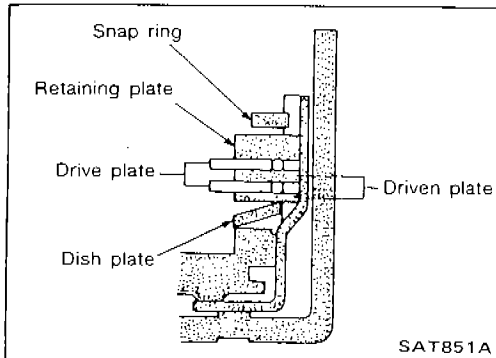
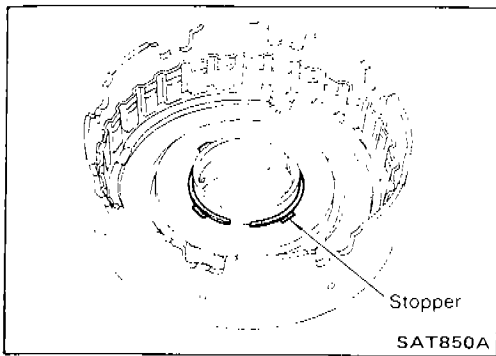

5. Install drive plates, driven plates, retaining plate and dish plate.

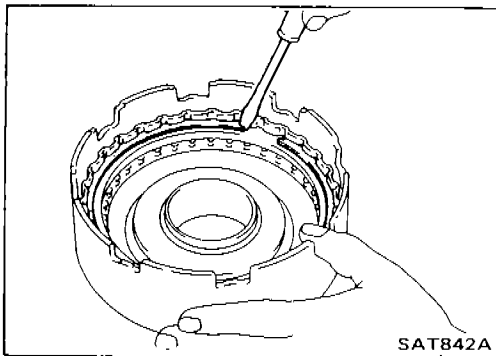

6. Install snap ring.

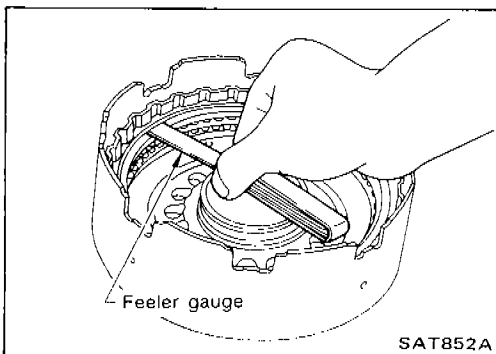

7. Measure clearance between retaining plate and snap ring. If not within allowable limit, select proper retaining plate.

Specified clearance:

Standard

0.5 - 0.8 mm (0.020 - 0.031 in)

Allowable limit

1.2 mm (0.047 in)

Retaining plate:

Refer to S.D.S.

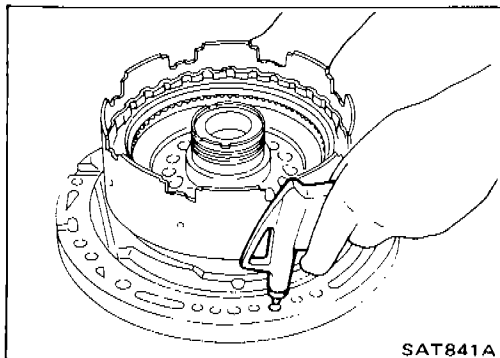

8. Check operation of reverse clutch.
Refer to "DISASSEMBLY" of Reverse Clutch.

High Clutch

For the number of clutch sheets (drive plate and driven plate), refer to the below cross-section.

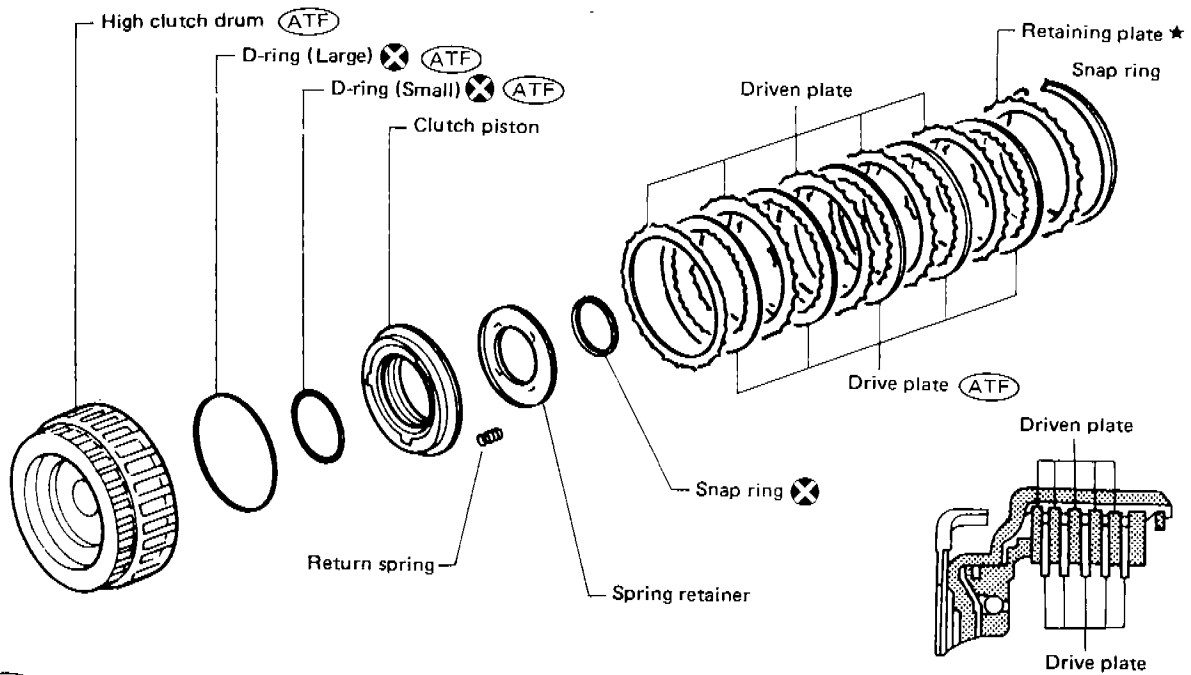

(ATF) : Apply A.T.F.
 ★ : Select with proper thickness.

SAT913B

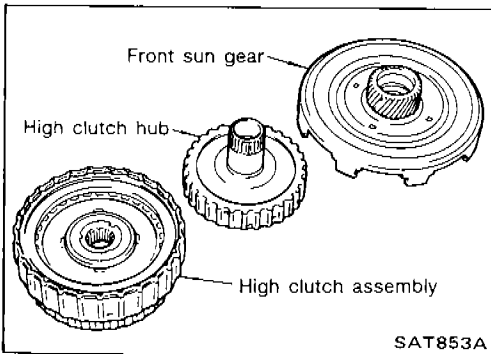

SAT853A

Service procedures for high clutch are essentially the same as those for reverse clutch, with the following exception:

- Check of high clutch operation

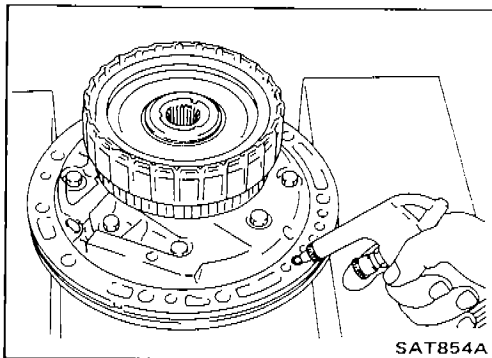

SAT854A

REPAIR FOR COMPONENT PARTS

High Clutch (Cont'd)

- Removal and installation of return spring

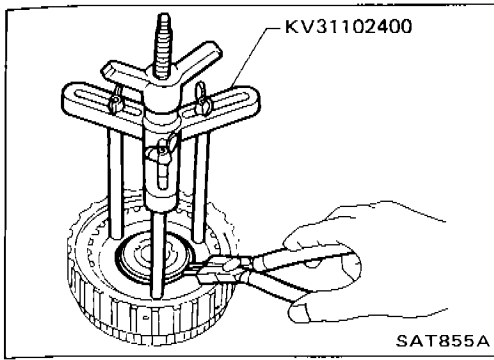

- Inspection of high clutch return springs

Inspection standard:

Unit: mm (in)

| Part No. | ℓ | D |
|-------------|----------------|--------------|
| 31505-21X03 | 22.06 (0.8685) | 11.6 (0.457) |

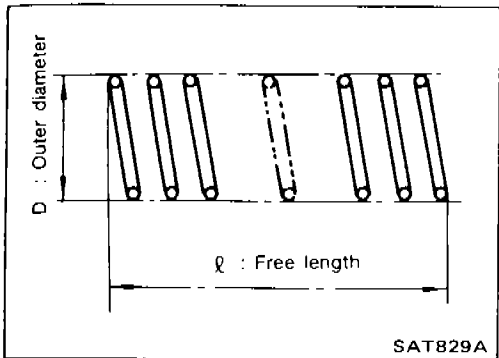

- Inspection of high clutch drive plate

Thickness of drive plate:

Standard

1.6 mm (0.063 in)

Wear limit

1.4 mm (0.055 in)

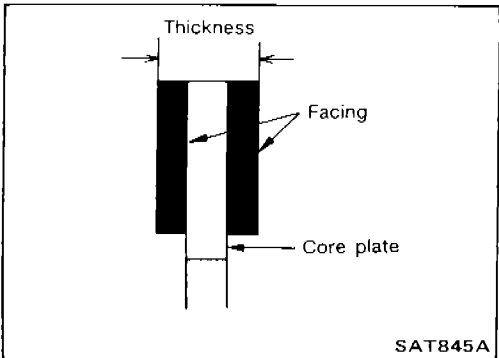

- Measurement of clearance between retaining plate and snap ring

Specified clearance:

Standard

1.8 - 2.2 mm (0.071 - 0.087 in)

Allowable limit

3.2 mm (0.126 in)

Retaining plate:

Refer to S.D.S.

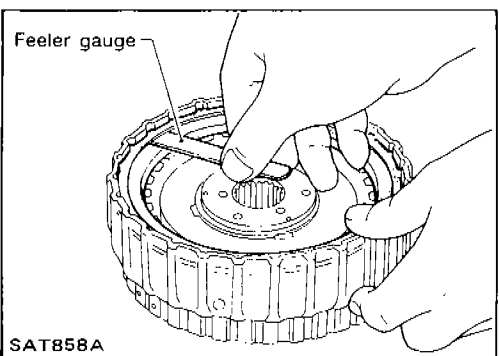

REPAIR FOR COMPONENT PARTS

Forward and Overrun Clutches

For the number of clutch sheets (drive plate and driven plate), refer to the below cross-section.

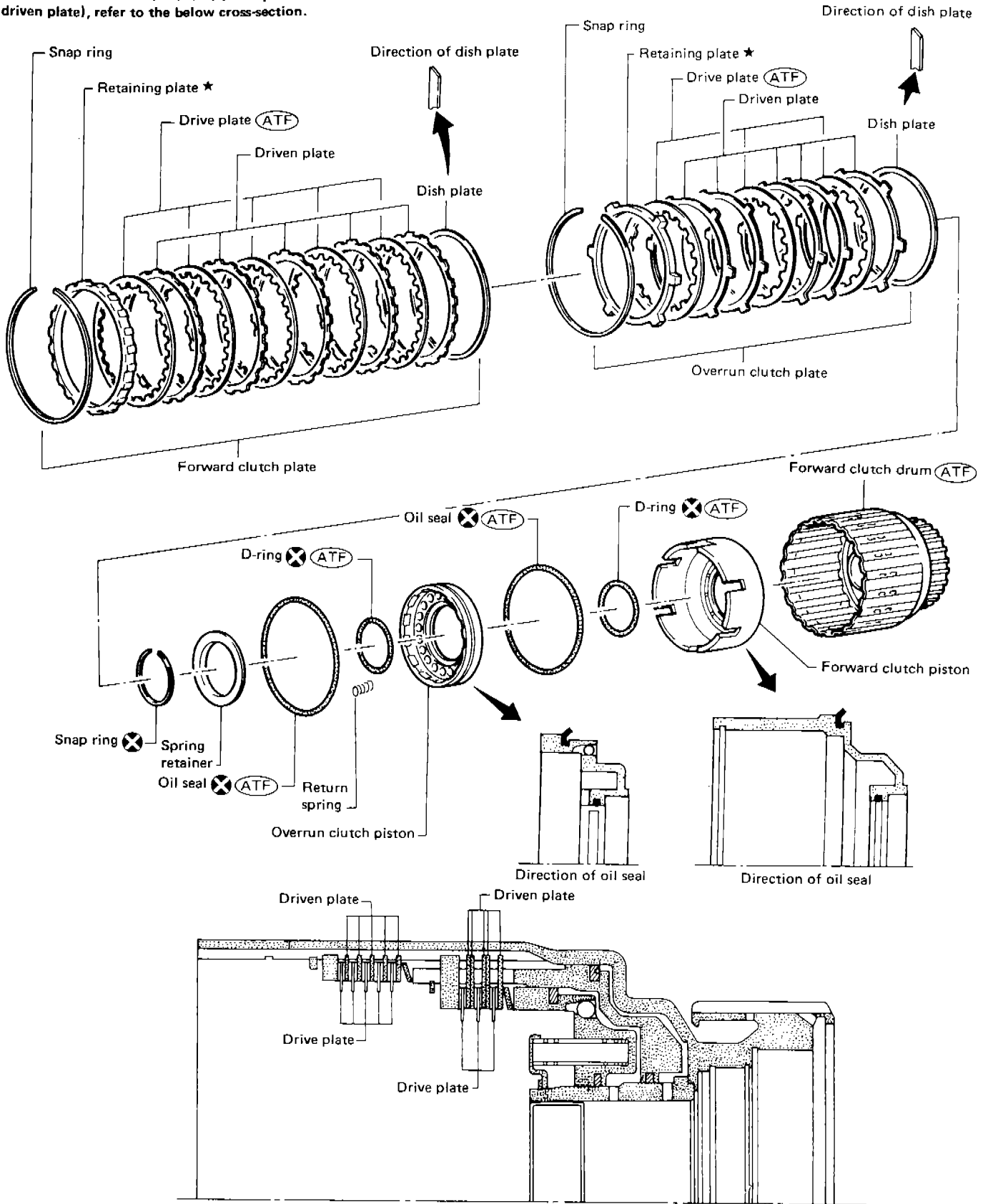

(ATF) : Apply A.T.F.

★ : Select with proper thickness.

SAT914B

AT-116

REPAIR FOR COMPONENT PARTS

Forward and Overrun Clutches (Cont'd)

Service procedures for forward and overrun clutches are essentially the same as those for reverse clutch, with the following exception:

- Check of forward clutch operation.

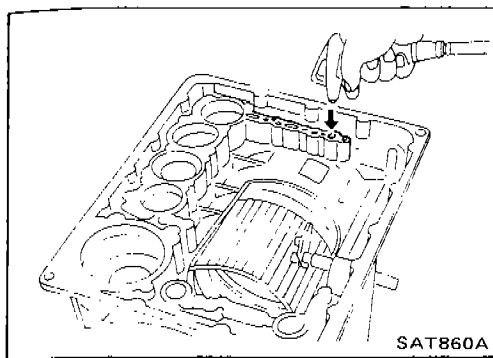

- Check of overrun clutch operation.

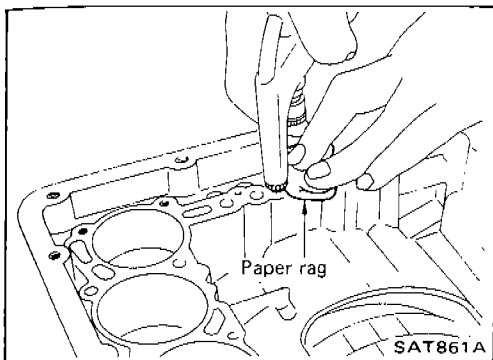

- Removal of forward clutch drum
Remove forward clutch drum from transmission case by holding snap ring.

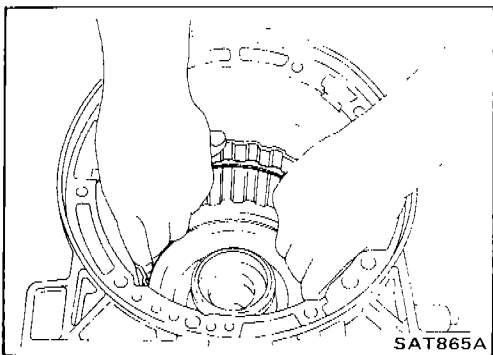

- Removal of forward clutch and overrun clutch pistons
1. While holding overrun clutch piston, gradually apply compressed air to oil hole.

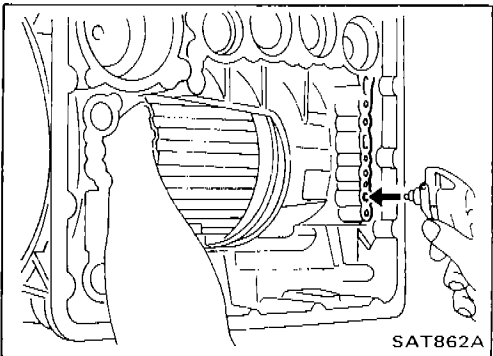

2. Remove overrun clutch from forward clutch.

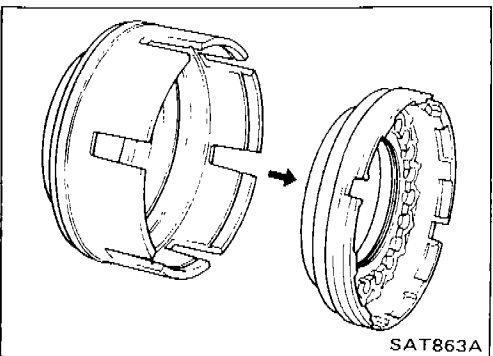

REPAIR FOR COMPONENT PARTS

Forward and Overrun Clutches (Cont'd)

- Removal and installation of return springs

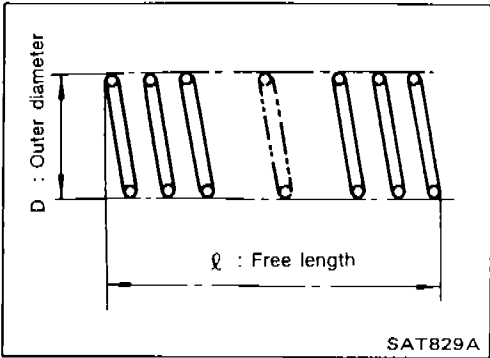
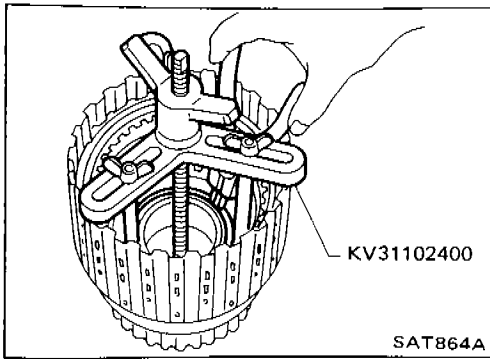

- Inspection of forward clutch and overrun clutch return springs

Inspection standard:

Unit: mm (in)

| Part No. | ℓ | D |
|-------------|----------------|-------------|
| 31505-41X01 | 35.77 (1.4083) | 9.7 (0.382) |

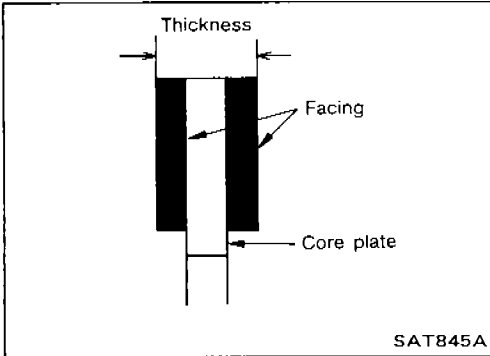

- Inspection of forward clutch drive plates

Thickness of drive plate:

Standard

2.0 mm (0.079 in)

Wear limit

1.8 mm (0.071 in)

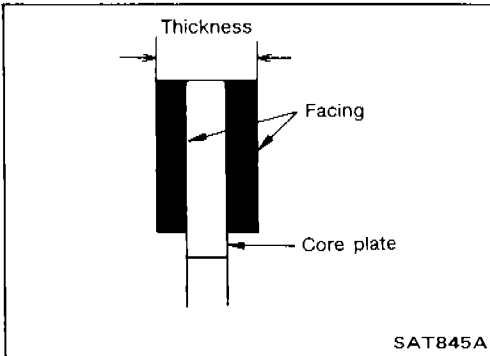

- Inspection of overrun clutch drive plates

Thickness of drive plate:

Standard

2.0 mm (0.079 in)

Wear limit

1.8 mm (0.071 in)

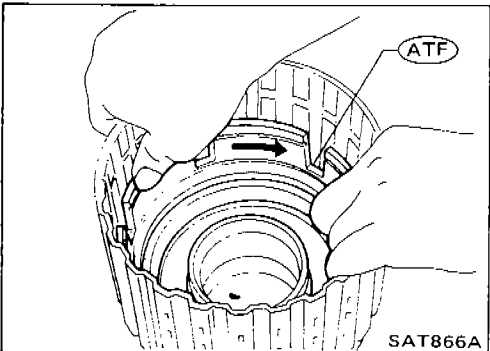

- Installation of forward clutch piston and overrun clutch piston

1. Install forward clutch piston by turning it slowly and evenly.

- Apply A.T.F. to inner surface of clutch drum.

REPAIR FOR COMPONENT PARTS

Forward and Overrun Clutches (Cont'd)

- Align notch in forward clutch piston with groove in forward clutch drum.

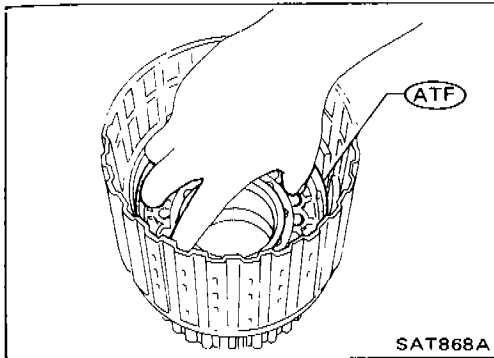
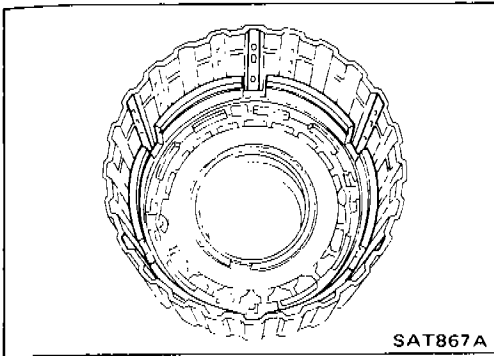

2. Install overrun clutch by turning it slowly and evenly.
- Apply A.T.F. to inner surface of forward clutch piston.

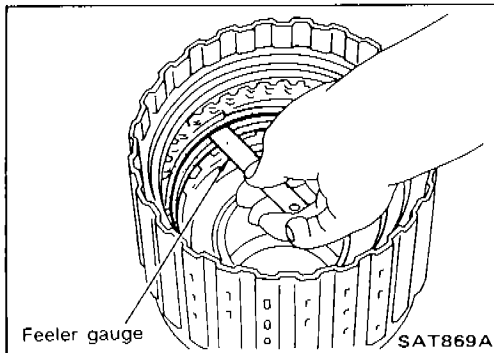

- Measurement of clearance between retaining plate and snap ring of overrun clutch

Specified clearance:

Standard

1.0 - 1.4 mm (0.039 - 0.055 in)

Allowable limit

2.0 mm (0.079 in)

Retaining plate:

Refer to S.D.S.

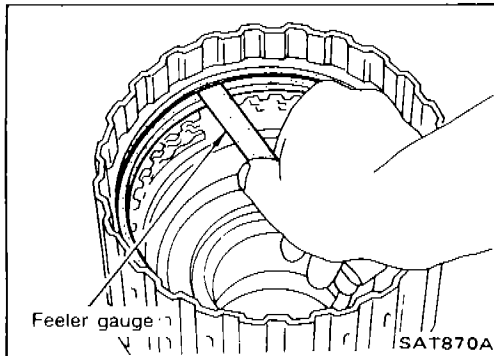

- Measurement of clearance between retaining plate and snap ring of forward clutch

Specified clearance:

Standard

0.45 - 0.85 mm (0.0177 - 0.0335 in)

Allowable limit

2.05 mm (0.0807 in)

Retaining plate:

Refer to S.D.S.

Low & Reverse Brake

For the number of clutch sheets (drive plate and driven plate), refer to the below cross-section.

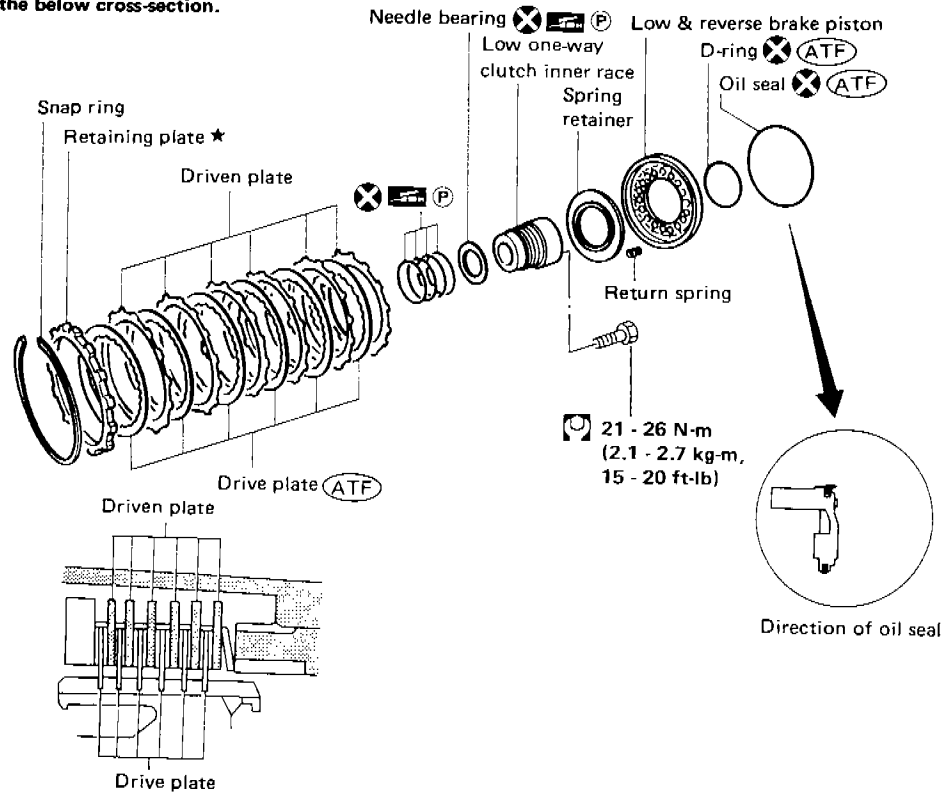

- (ATF) : Apply A.T.F.
- ⊗ P : Apply petroleum jelly.
- ★ : Select with proper thickness.

SAT915B

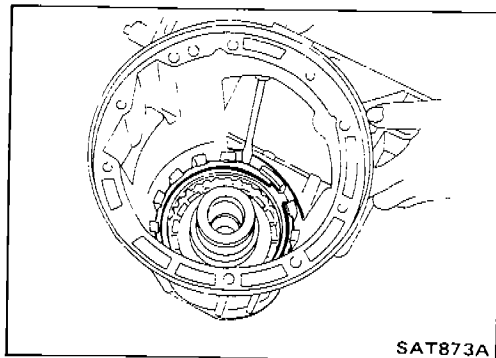
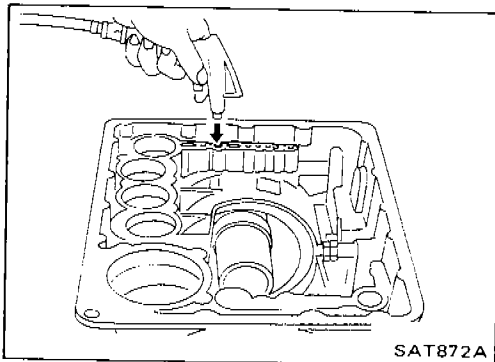

DISASSEMBLY

1. Check operation of low and reverse brake.
 - a. Install seal ring onto oil pump cover and install reverse clutch. Apply compressed air to oil hole.
 - b. Check to see that retaining plate moves to snap ring.
 - c. If retaining plate does not move to snap ring, D-ring or oil seal may be damaged or fluid may be leaking at piston check ball.
2. Remove snap ring, low and reverse brake drive plates, driven plates and dish plate.

REPAIR FOR COMPONENT PARTS

Low & Reverse Brake (Cont'd)

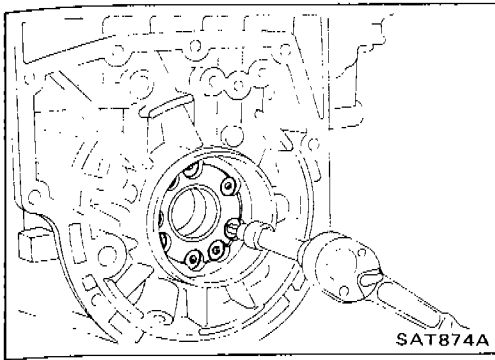

- Remove low one-way clutch inner race, spring retainer and return spring from transmission case.

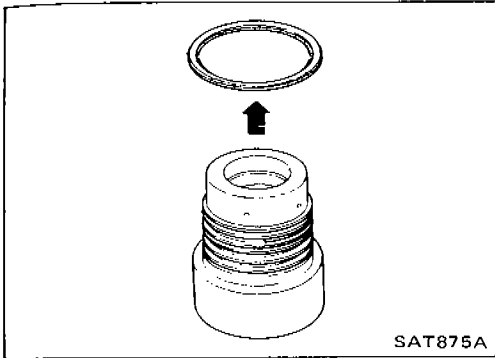

- Remove seal rings from low one-way clutch inner race.
- Remove needle bearing from low one-way clutch inner race.

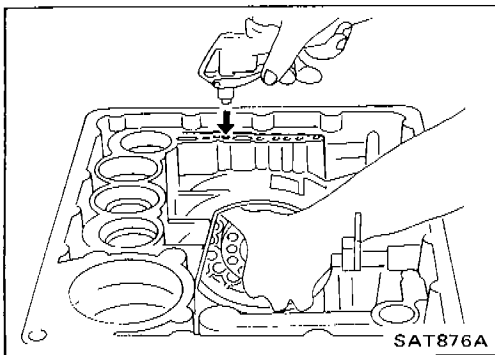

- Remove low and reverse brake piston using compressed air.
- Remove oil seal and D-ring from piston.

INSPECTION

Low and reverse brake snap ring and spring retainer

- Check for deformation, or damage.

Low and reverse brake return springs

- Check for deformation or damage. Also measure free length and outside diameter.

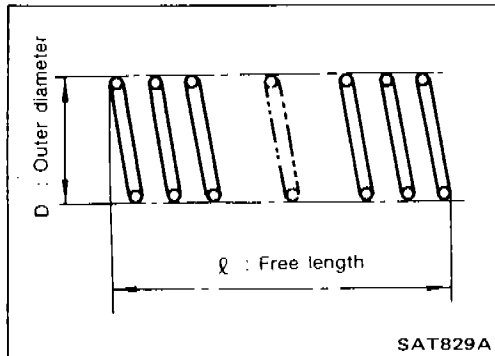

Inspection standard:

Unit: mm (in)

| Part No. | ℓ | D |
|-------------|--------------|--------------|
| 31521-21X00 | 23.7 (0.933) | 11.6 (0.457) |

Low and reverse brake drive plates

- Check facing for burns, cracks or damage.
- Measure thickness of facing.

Thickness of drive plate:

Standard value

2.0 mm (0.079 in)

Wear limit

1.8 mm (0.071 in)

- If not within wear limit, replace.

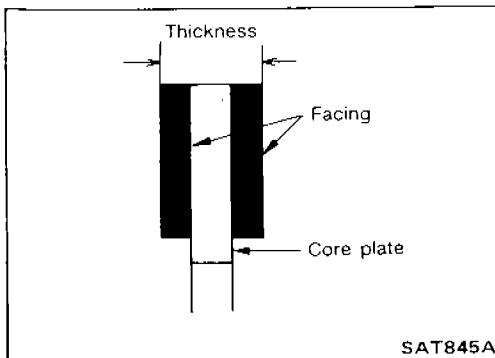

REPAIR FOR COMPONENT PARTS

Low & Reverse Brake (Cont'd)

Low one-way clutch inner race

- Check frictional surface of inner race for wear or damage.

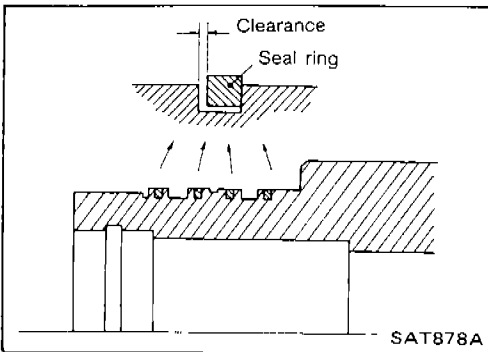
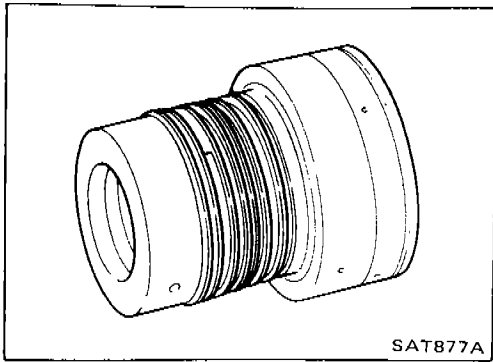

- Install a new seal rings onto low one-way clutch inner race.
- **Be careful not to expand seal ring gap excessively.**
- Measure seal ring-to-groove clearance.

Inspection standard:

Standard value 0.10 - 0.25 mm (0.0039 - 0.0098 in)

Allowable limit 0.25 mm (0.0098 in)

- If not within allowable limit, replace low one-way clutch inner race.

ASSEMBLY

1. Install bearing onto one-way clutch inner race.
 - Pay attention to its direction — **Black surface goes to rear side.**
 - Apply petroleum jelly to needle bearing.

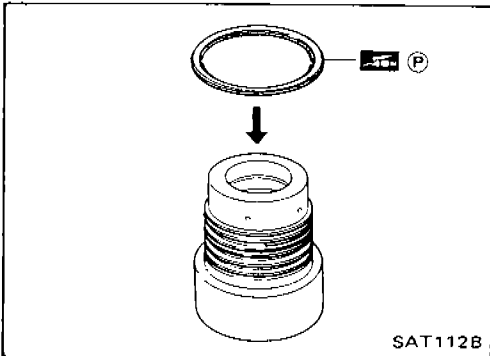

2. Install oil seal and D-ring onto piston.
 - Apply A.T.F. to oil seal and D-ring.

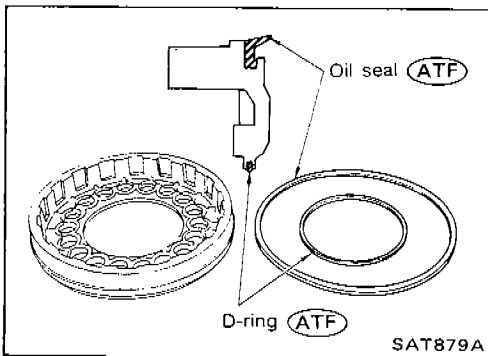

3. Install piston by rotating it slowly and evenly.
 - Apply A.T.F. to inner surface of transmission case.

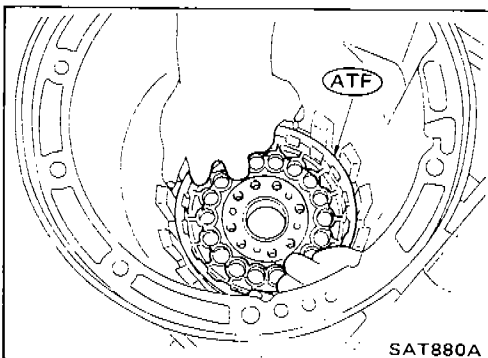

REPAIR FOR COMPONENT PARTS

Low & Reverse Brake (Cont'd)

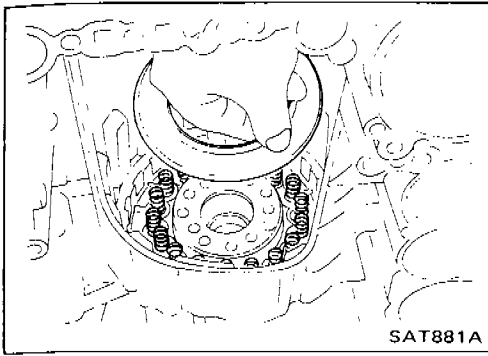

4. Install return springs, spring retainer and low one-way clutch inner race onto transmission case.

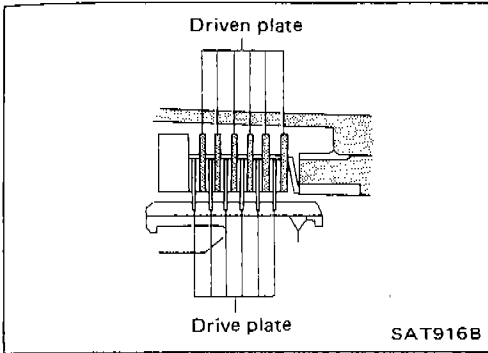

5. Install dish plate, low and reverse brake drive plates, driven plates and retaining plate.
6. Install snap ring on transmission case.

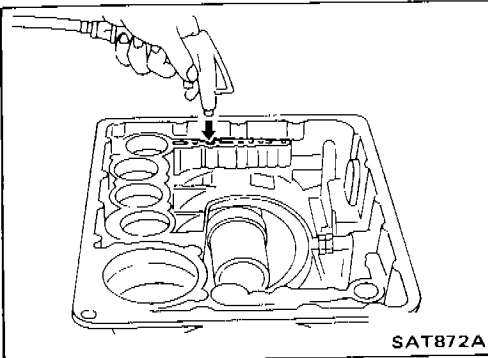

7. Check operation of low and reverse brake clutch piston. Refer to "DISASSEMBLY".

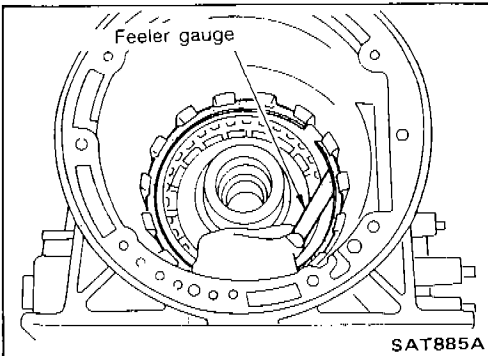

8. Measure clearance between retaining plate and snap ring. If not within allowable limit, select proper retaining plate.

Specified clearance:

Standard

1.1 - 1.5 mm (0.043 - 0.059 in)

Allowable limit

2.5 mm (0.098 in)

Retaining plate:

Refer to S.D.S.

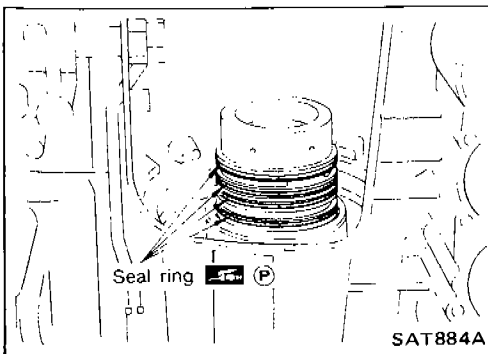

9. Install low one-way clutch inner race seal ring.
 - Apply petroleum jelly to seal ring.
 - Make sure seal rings are pressed firmly into place and held by petroleum jelly.

Forward Clutch Drum Assembly

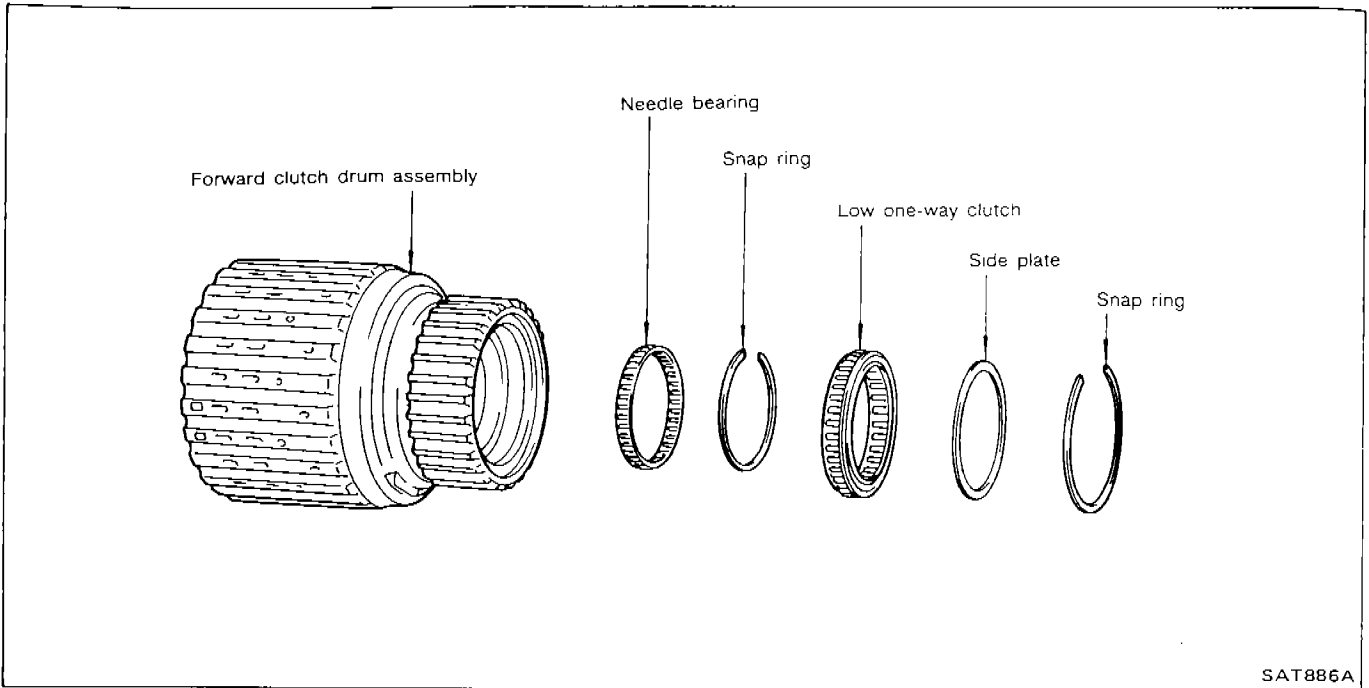

SAT886A

DISASSEMBLY

1. Remove snap ring from forward clutch drum.

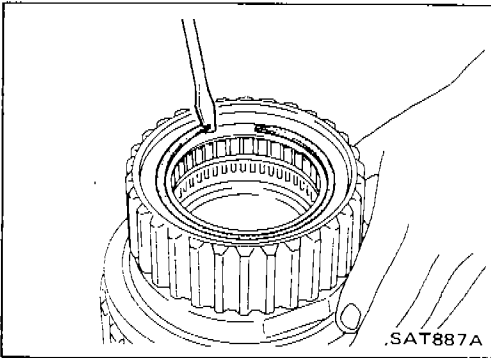

2. Remove side plate from forward clutch drum.

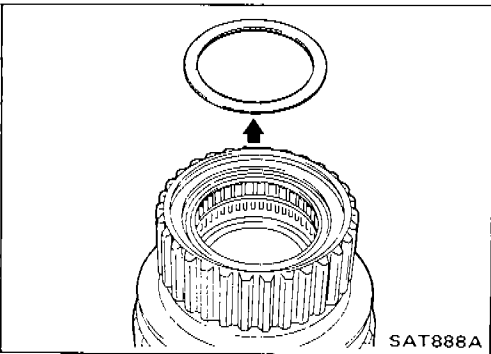

3. Remove low one-way clutch from forward clutch drum.

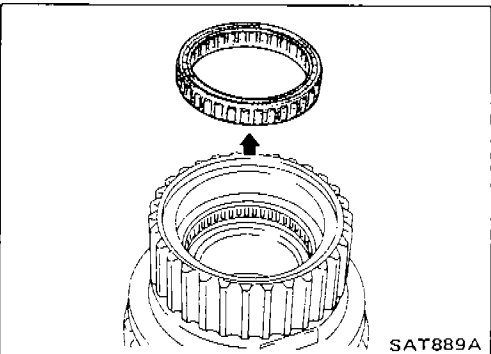

REPAIR FOR COMPONENT PARTS

Forward Clutch Drum Assembly (Cont'd)

4. Remove snap ring from forward clutch drum.

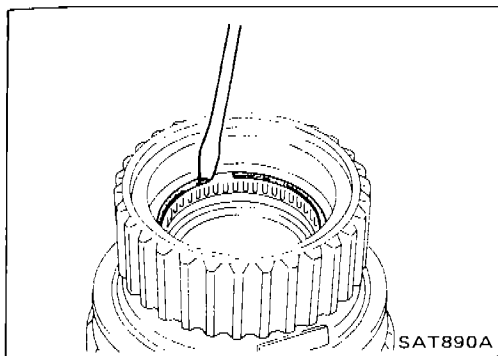

5. Remove needle bearing from forward clutch drum.

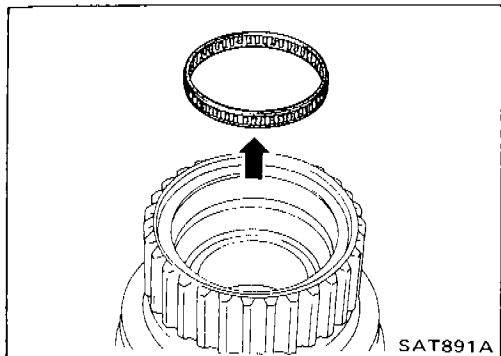

INSPECTION

Forward clutch drum

- Check spline portion for wear or damage.
- Check frictional surfaces of low one-way clutch and needle bearing for wear or damage.

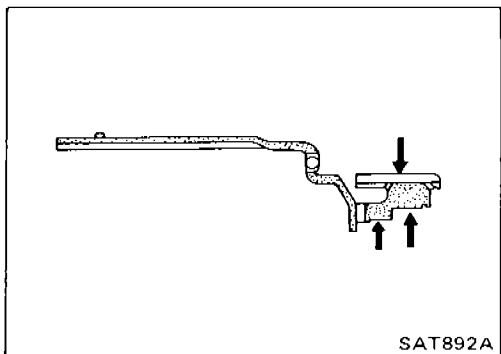

Needle bearing and low one-way clutch

- Check frictional surface for wear or damage.

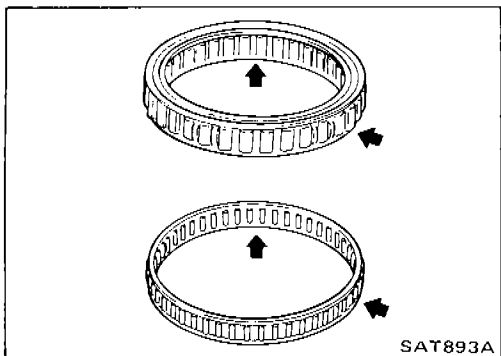

ASSEMBLY

1. Install needle bearing in forward clutch drum.

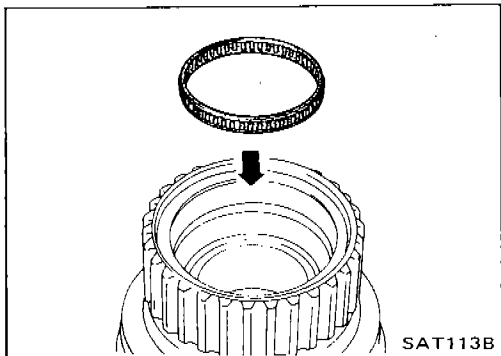

REPAIR FOR COMPONENT PARTS

Forward Clutch Drum Assembly (Cont'd)

2. Install snap ring onto forward clutch drum.

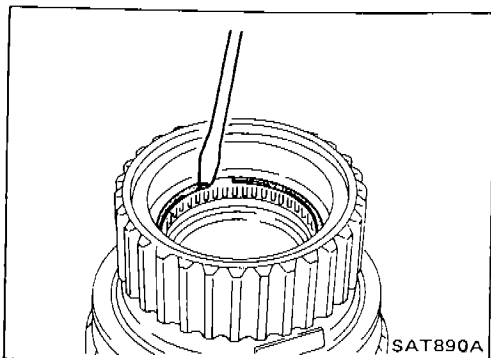

SAT890A

3. Install low one-way clutch onto forward clutch drum by pushing the roller in evenly.

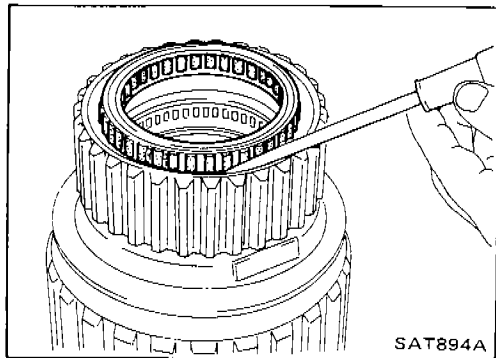

SAT894A

● Install low one-way clutch with flange facing rearward.

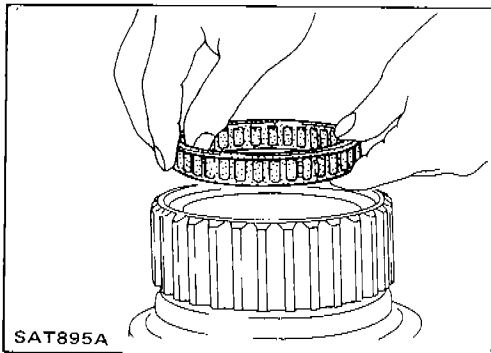

SAT895A

4. Install side plate onto forward clutch drum.
5. Install snap ring onto forward clutch drum.

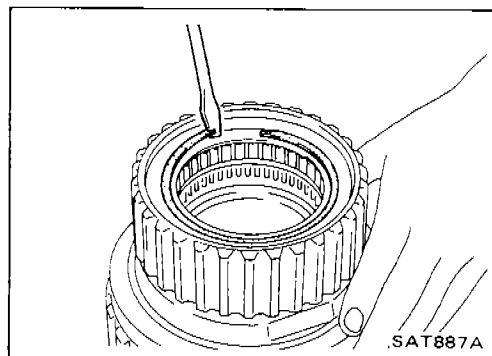

SAT887A

REPAIR FOR COMPONENT PARTS

Rear Internal Gear and Forward Clutch Hub

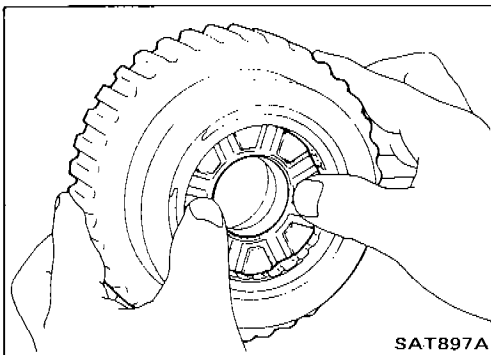
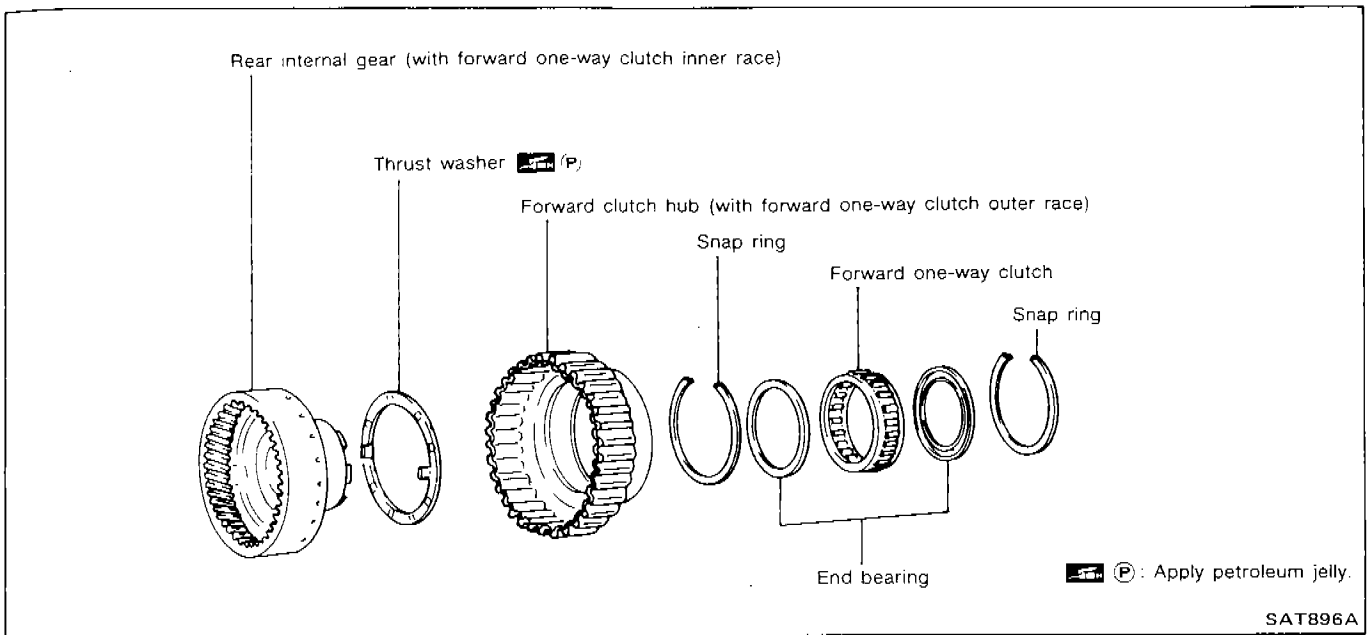

DISASSEMBLY

1. Remove rear internal gear by pushing forward clutch hub forward.

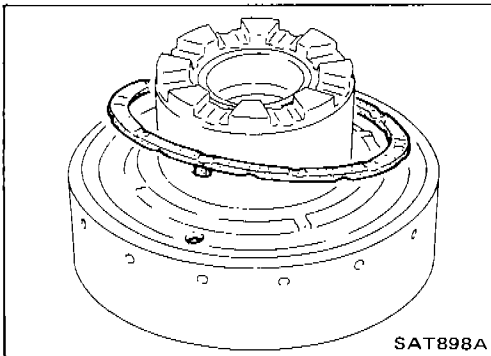

2. Remove thrust washer from rear internal gear.

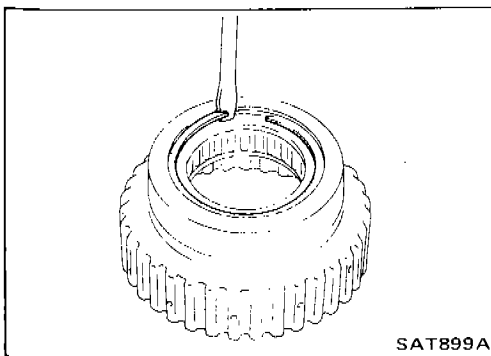

3. Remove snap ring from forward clutch hub.

REPAIR FOR COMPONENT PARTS

Rear Internal Gear and Forward Clutch Hub (Cont'd)

4. Remove end bearing.

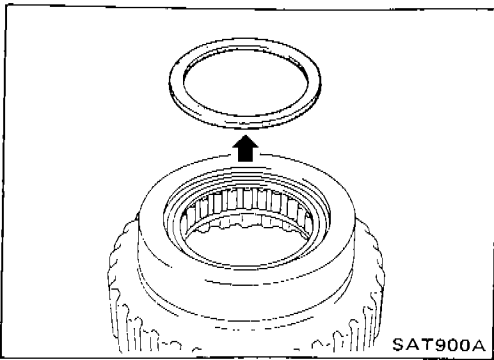

5. Remove forward one-way clutch and end bearing as a unit from forward clutch hub.

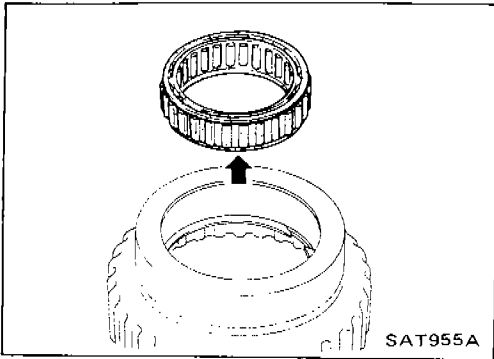

6. Remove snap ring from forward clutch hub.

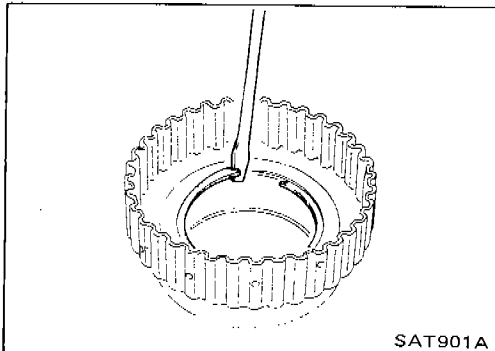

INSPECTION

Rear internal gear and forward clutch hub

- Check gear for excessive wear, chips or cracks.
- Check frictional surfaces of forward one-way clutch and thrust washer for wear or damage.
- Check spline for wear or damage.

Snap ring and end bearing

- Check for deformation or damage.

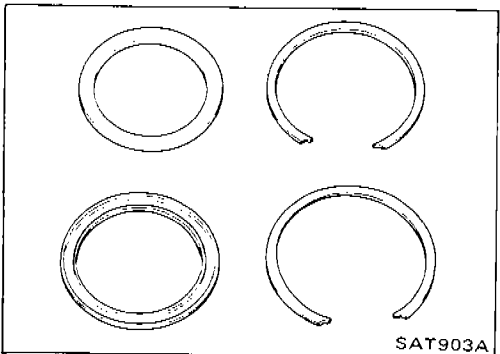
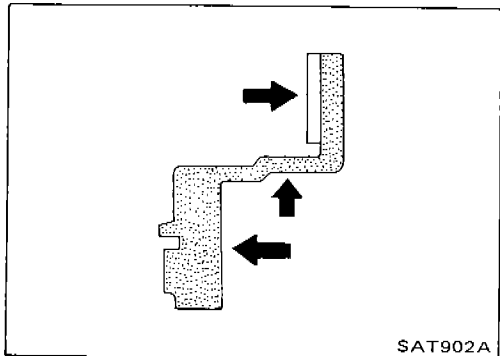

REPAIR FOR COMPONENT PARTS

Rear Internal Gear and Forward Clutch Hub (Cont'd)

ASSEMBLY

1. Install snap ring onto forward clutch hub.
2. Install end bearing.
3. Install forward one-way clutch onto clutch hub.
 - **Install forward one-way clutch with flange facing rearward.**
4. Install end bearing.
5. Install snap ring onto forward clutch hub.
6. Install thrust washer onto rear internal gear.
 - **Apply petroleum jelly to thrust washer.**
 - **Securely insert pawls of thrust washer into holes in rear internal gear.**
7. Position forward clutch hub in rear internal gear.
8. After installing, check to assure that forward clutch hub rotates clockwise.

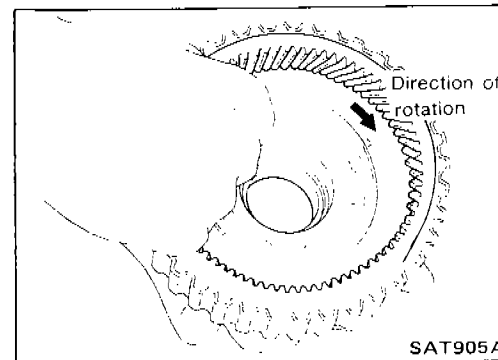
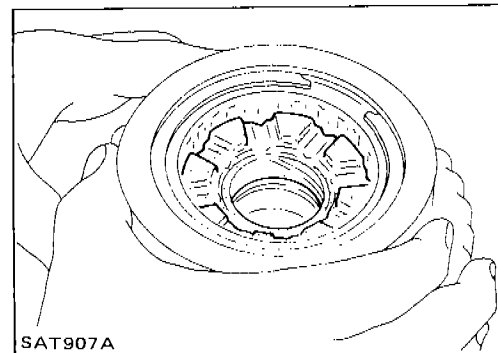
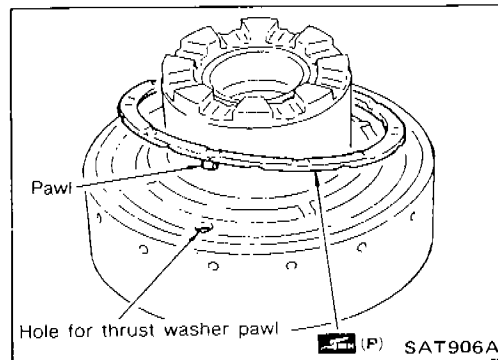
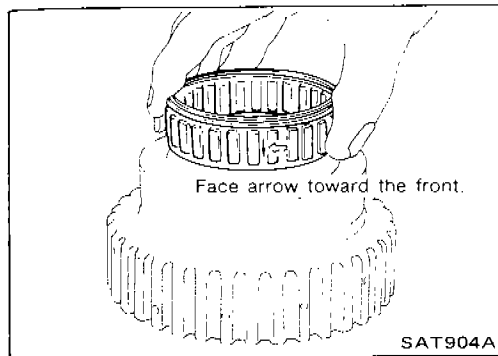
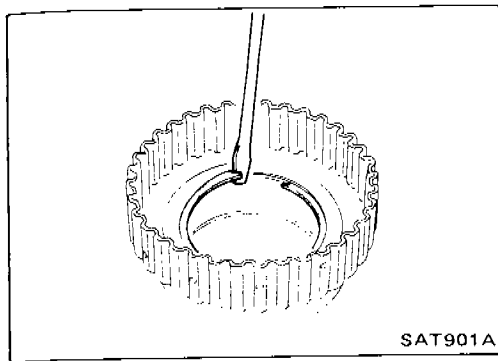

Band Servo Piston Assembly

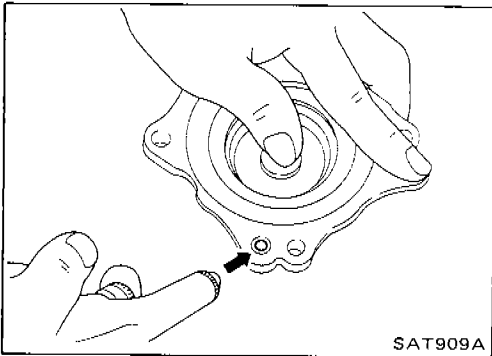
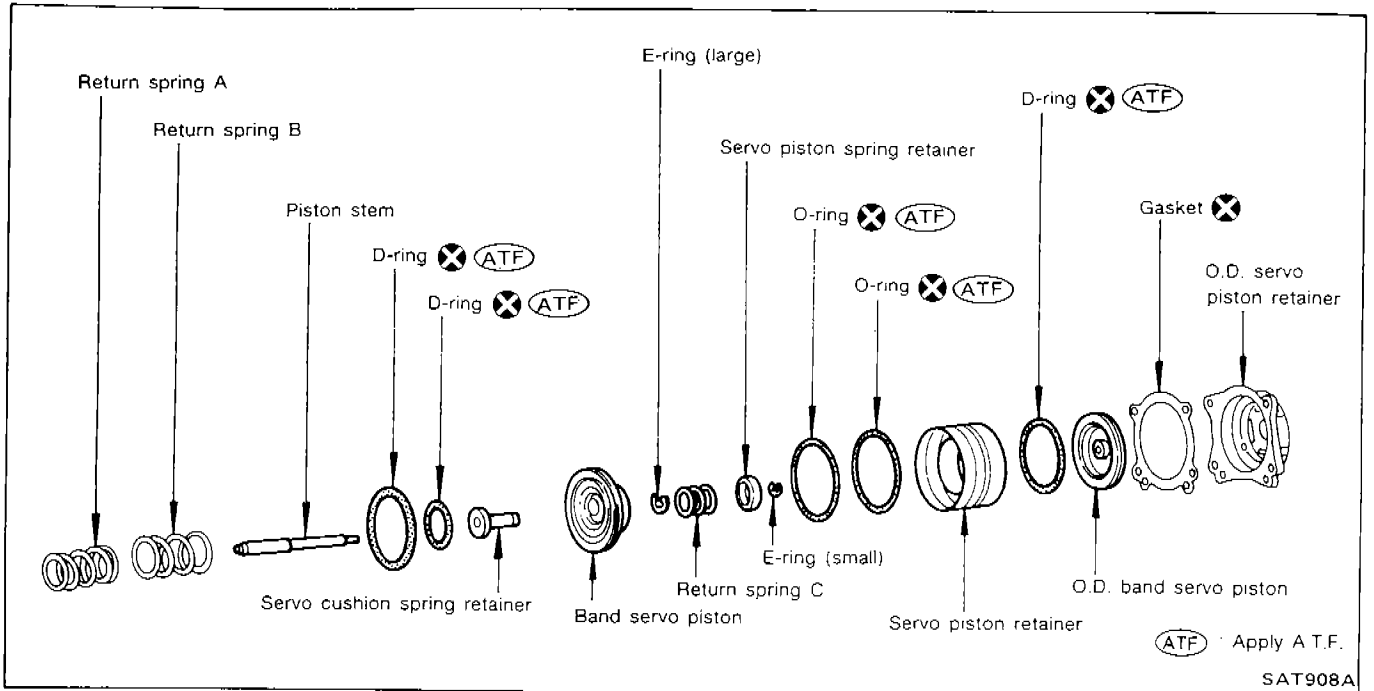

DISASSEMBLY

1. Block one oil hole in O.D. servo piston retainer and the center hole in O.D. band servo piston.
2. Apply compressed air to the other oil hole in piston retainer to remove O.D. band servo piston from retainer.
3. Remove D-ring from O.D. band servo piston.

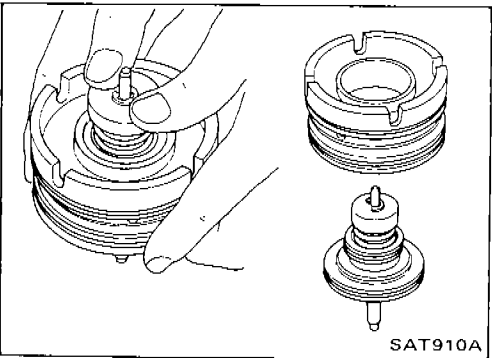

4. Remove band servo piston assembly from servo piston retainer by pushing it forward.

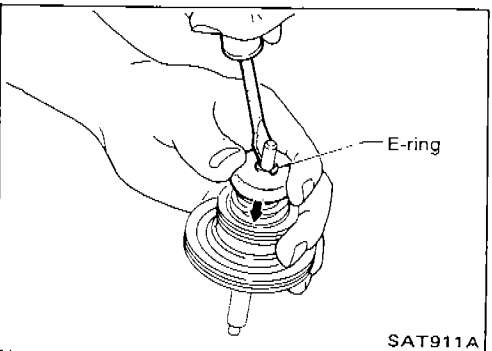

5. Place piston stem end on a wooden block. While pushing servo piston spring retainer down, remove E-ring.

REPAIR FOR COMPONENT PARTS

Band Servo Piston Assembly (Cont'd)

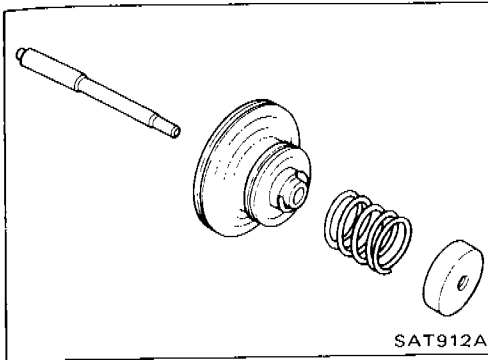

6. Remove servo piston spring retainer, return spring C and piston stem from band servo piston.

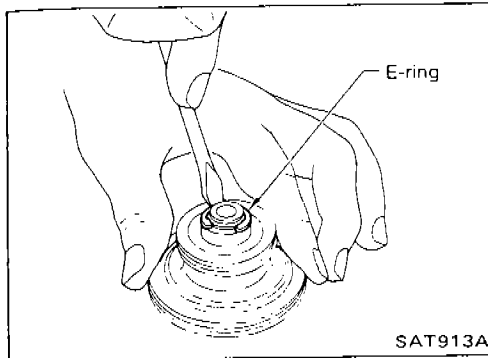

7. Remove E-ring from band servo piston.

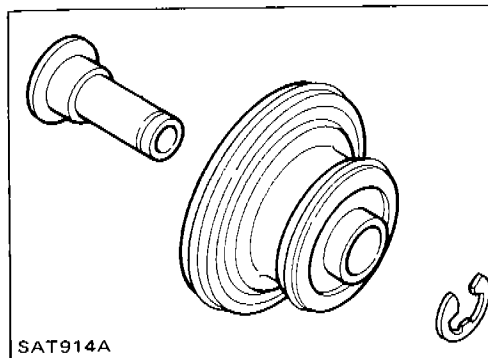

8. Remove servo cushion spring retainer from band servo piston.
9. Remove D-rings from band servo piston.
10. Remove O-rings from servo piston retainer.

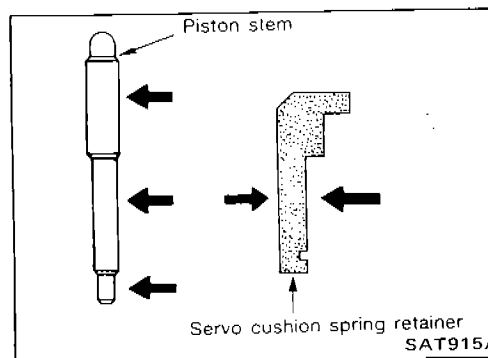

INSPECTION

Pistons, retainers and piston stem

- Check frictional surfaces for abnormal wear or damage.

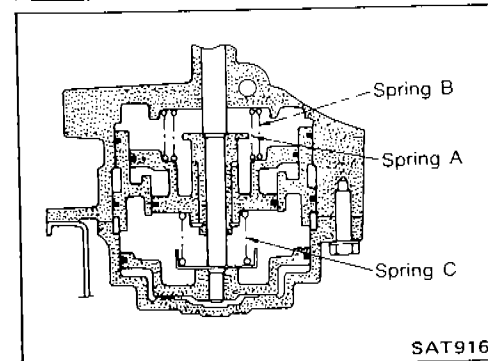

Return springs

- Check for deformation or damage. Measure free length and outer diameter.

Inspection standard:

Unit: mm (in)

| Parts | Free length | Outer diameter |
|----------|--------------|----------------|
| Spring A | 45.6 (1.795) | 34.3 (1.350) |
| Spring B | 53.8 (2.118) | 40.3 (1.587) |
| Spring C | 29.0 (1.142) | 27.6 (1.087) |

REPAIR FOR COMPONENT PARTS

Band Servo Piston Assembly (Cont'd)

ASSEMBLY

1. Install O-rings onto servo piston retainer.
 - Apply A.T.F. to O-rings.
 - Pay attention to position of each O-ring.

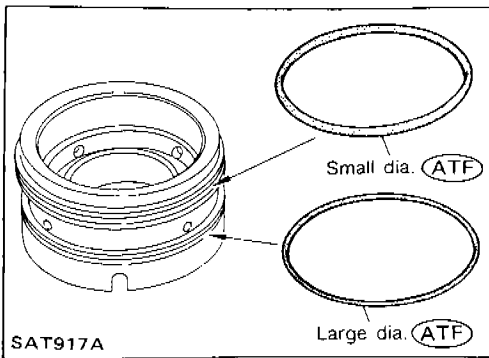

2. Install servo cushion spring retainer onto band servo piston.

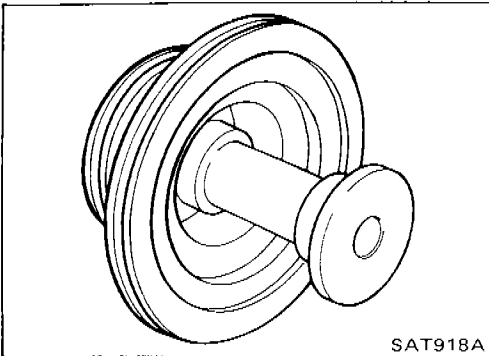

3. Install E-ring onto servo cushion spring retainer.

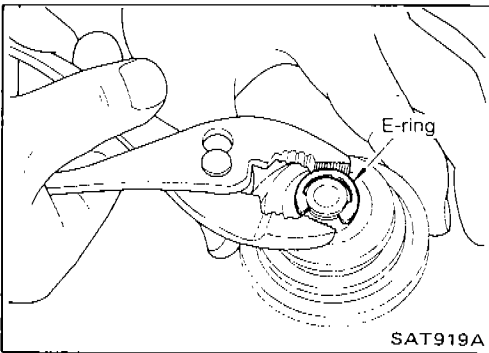

4. Install D-rings onto band servo piston.
 - Apply A.T.F. to D-rings.

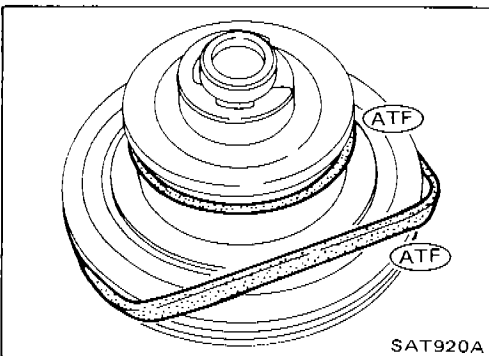

5. Install servo piston spring retainer, return spring C and piston stem onto band servo piston.

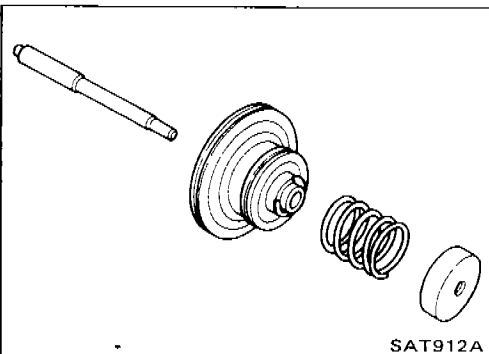

REPAIR FOR COMPONENT PARTS

Band Servo Piston Assembly (Cont'd)

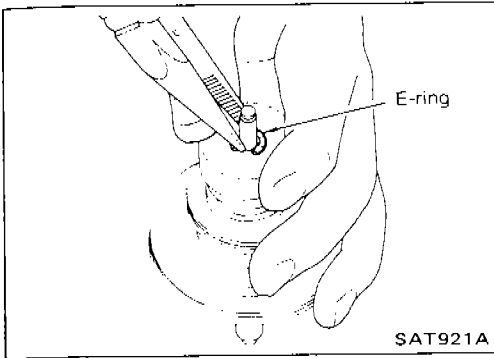

6. Place piston stem end on a wooden block. While pushing servo piston spring retainer down, install E-ring.

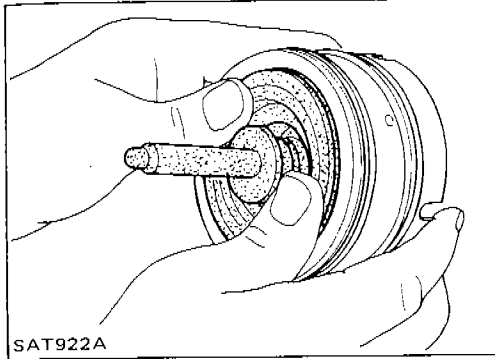

7. Install band servo piston assembly onto servo piston retainer by pushing it inward.

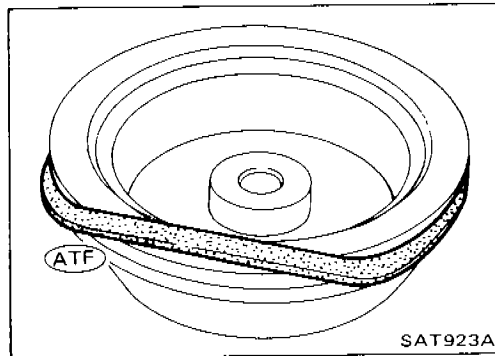

8. Install D-ring on O.D. band servo piston.
● **Apply A.T.F. to D-ring.**

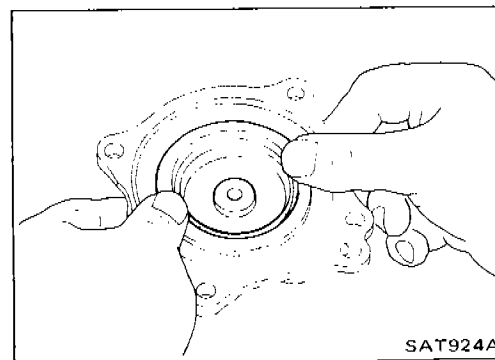

9. Install O.D. band servo piston onto servo piston retainer by pushing it inward.

Parking Pawl Components

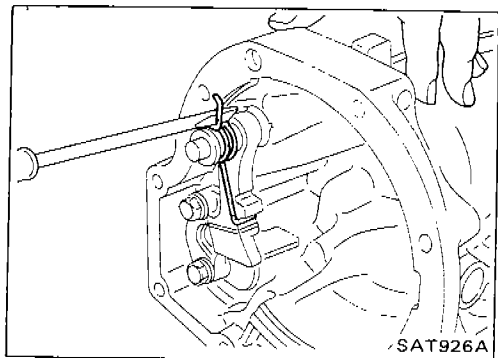
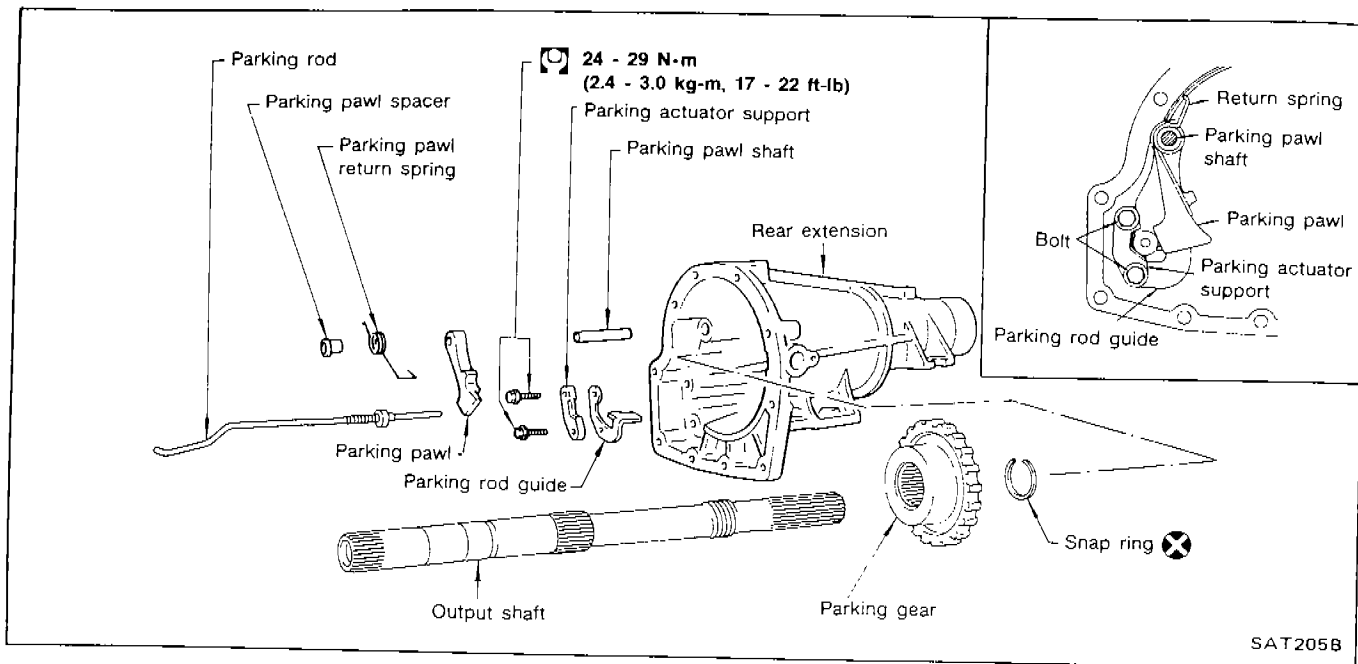

DISASSEMBLY

1. Slide return spring to the front of rear extension flange.

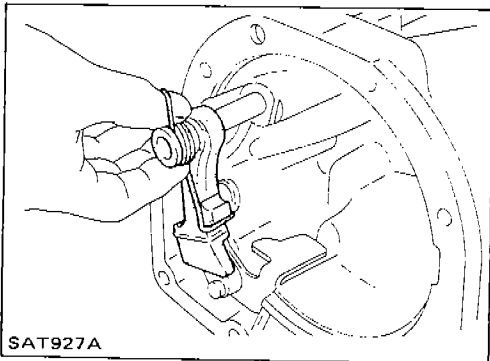

2. Remove return spring, pawl spacer and parking pawl from rear extension.

3. Remove parking pawl shaft from rear extension.

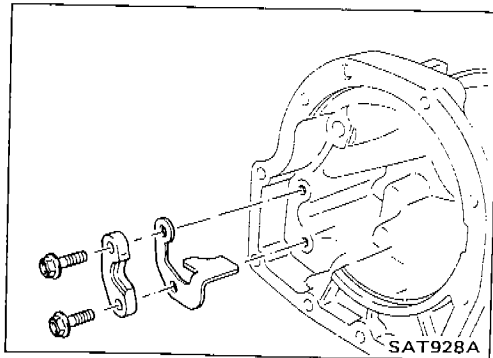

4. Remove parking actuator support and rod guide from rear extension.

REPAIR FOR COMPONENT PARTS

Parking Pawl Components (Cont'd)

INSPECTION

Parking pawl and parking actuator support

- Check contact surface of parking rod for wear.

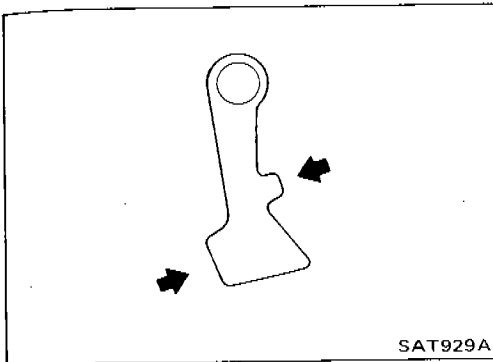

SAT929A

ASSEMBLY

1. Install rod guide and parking actuator support onto rear extension.
2. Insert parking pawl shaft into rear extension.

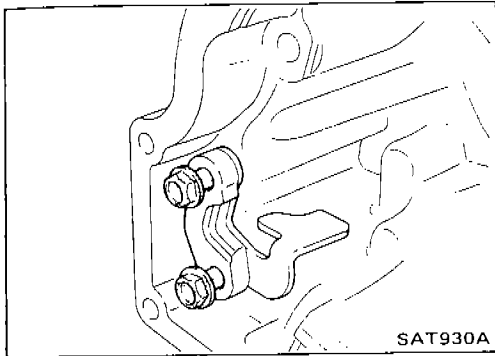

SAT930A

3. Install return spring, pawl spacer and parking pawl onto parking pawl shaft.

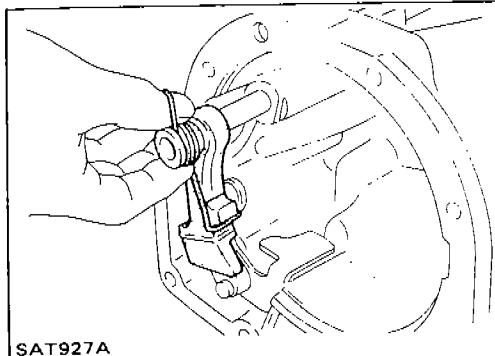

SAT927A

4. Bend return spring upward and install it onto rear extension.

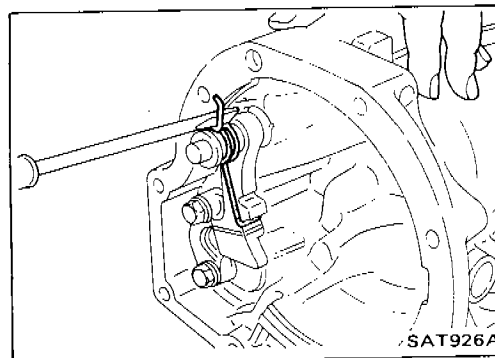

SAT926A

ASSEMBLY

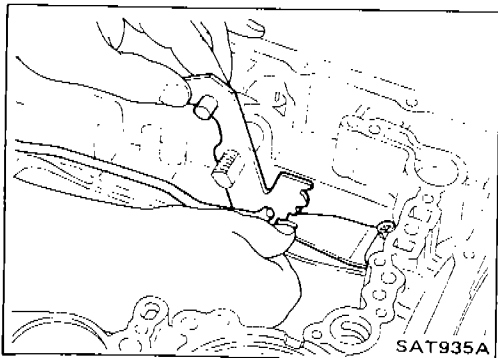
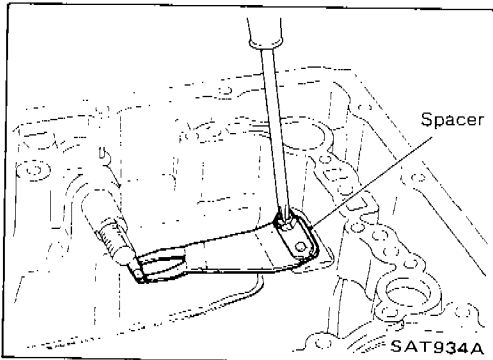
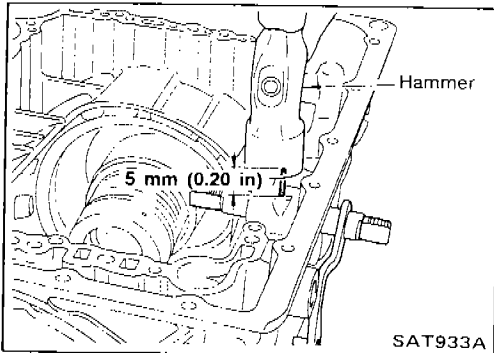
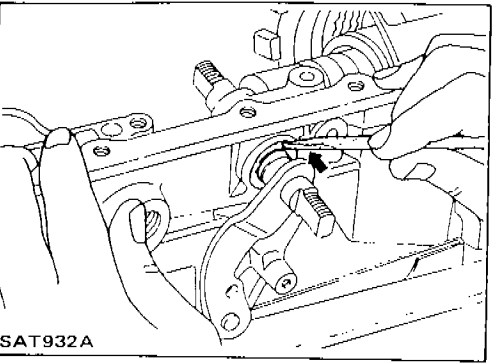
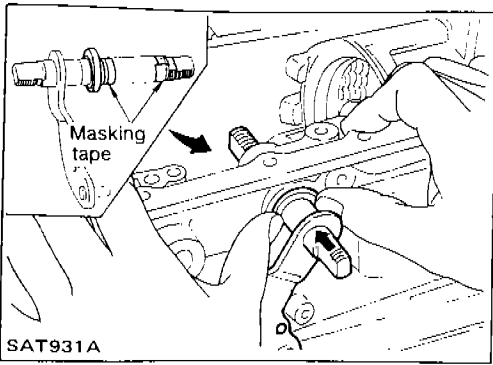

Assembly

1. Install manual shaft components.
 - a. Install oil seal onto manual shaft.
 - **Apply A.T.F. to oil seal.**
 - **Wrap threads of manual shaft with masking tape.**
 - b. Insert manual shaft and oil seal as a unit into transmission case.
 - c. Remove masking tape.
- d. Push oil seal evenly and install it onto transmission case.
- e. Align groove in shaft with drive pin hole, then drive pin into position as shown in figure at left.
- f. Install detent spring and spacer.
- g. While pushing detent spring down, install manual plate onto manual shaft.

ASSEMBLY

Assembly (Cont'd)

h. Install lock nuts onto manual shaft.

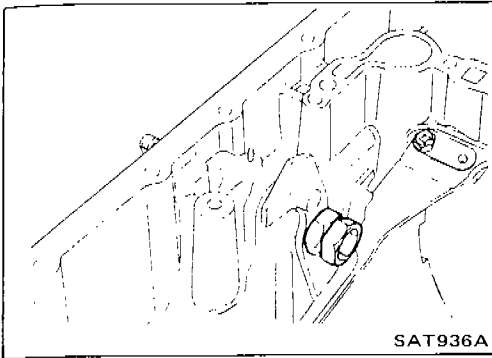

2. Install accumulator piston.

a. Install O-rings onto accumulator piston.

● **Apply A.T.F. to O-rings.**

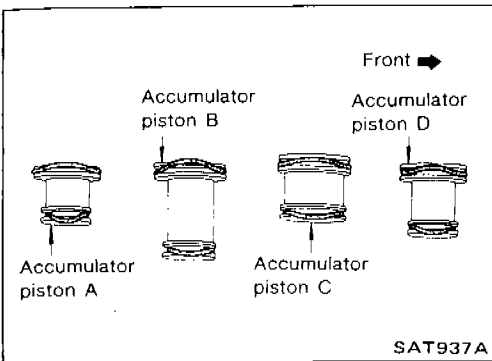

Accumulator piston O-rings:

Unit: mm (in)

| Accumulator | A | B | C | D |
|--------------------|-----------|-----------|-----------|-----------|
| Small diameter end | 29 (1.14) | 32 (1.26) | 45 (1.77) | 29 (1.14) |
| Large diameter end | 45 (1.77) | 50 (1.97) | 50 (1.97) | 45 (1.77) |

b. Install return spring for accumulator A onto transmission case.

Free length of return spring:

Unit: mm (in)

| Accumulator | A |
|-------------|-----------|
| Free length | 43 (1.69) |

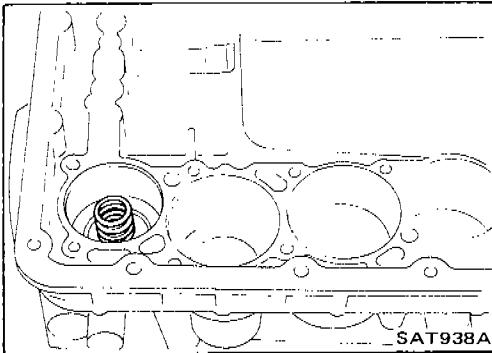

c. Install accumulator pistons A, B, C and D.

● **Apply A.T.F. to transmission case.**

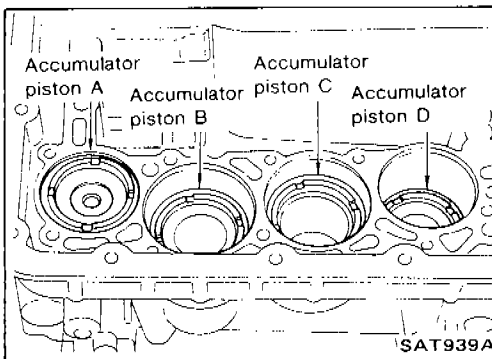

3. Install band servo piston.

a. Install return springs onto servo piston.

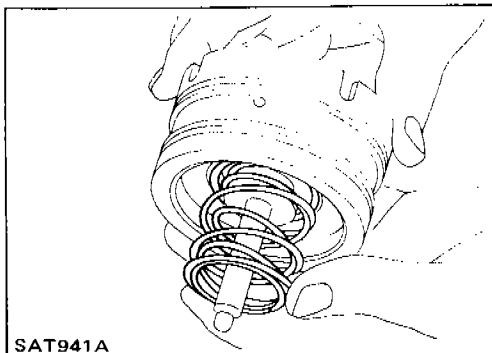

ASSEMBLY

Assembly (Cont'd)

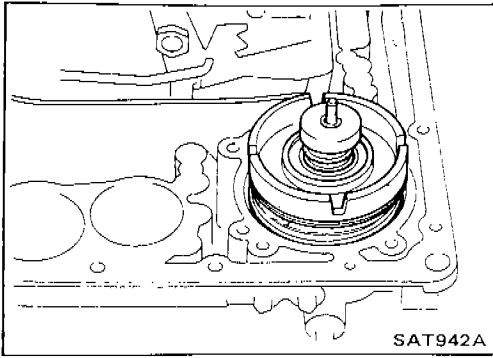

- b. Install band servo piston onto transmission case.
 - Apply A.T.F. to O-ring of band servo piston and transmission case.
- c. Install gasket for band servo onto transmission case.

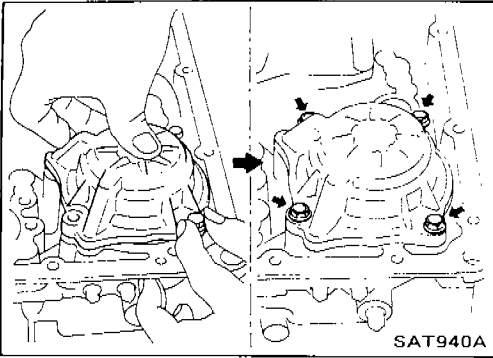

- d. Install band servo retainer onto transmission case.

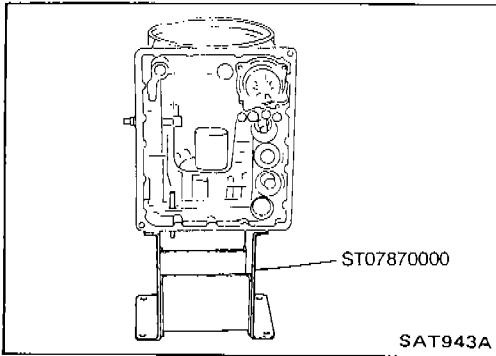

- 4. Install rear side clutch and gear components.
 - a. Place transmission case in vertical position.

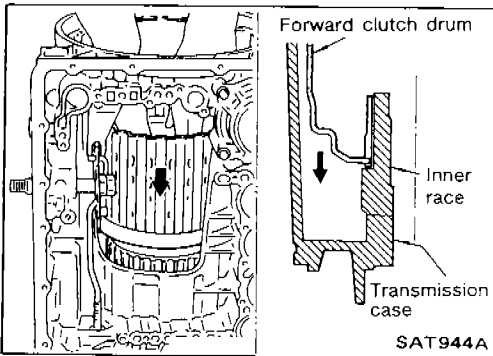

- b. Slightly lift forward clutch drum assembly and slowly rotate it clockwise until its hub passes fully over the clutch inner race inside transmission case.

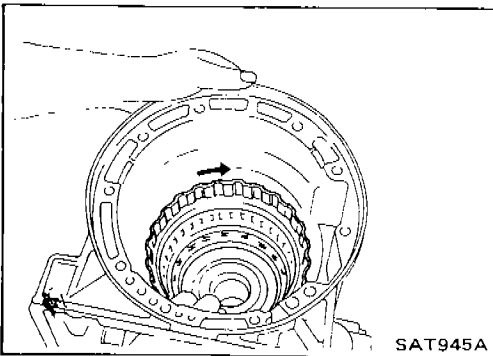

- c. Check to be sure that rotation direction of forward clutch assembly is correct.

ASSEMBLY

Assembly (Cont'd)

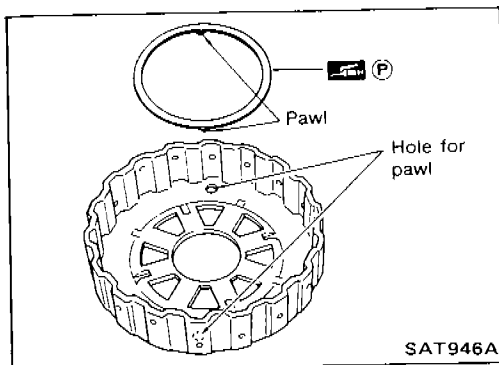

- d. Install thrust washer onto front of overrun clutch hub.
- Apply petroleum jelly to the thrust washer.
 - Insert pawls of thrust washer securely into holes in overrun clutch hub.

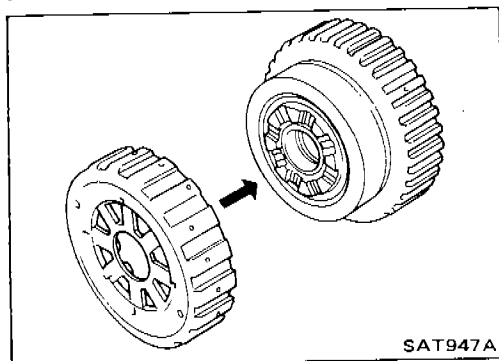

- e. Install overrun clutch hub onto rear internal gear assembly.

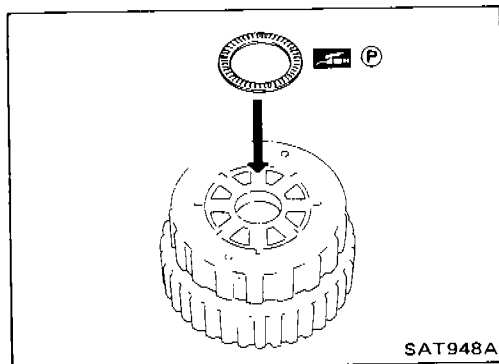

- f. Install needle bearing onto rear of overrun clutch hub.
- Apply petroleum jelly to needle bearing.

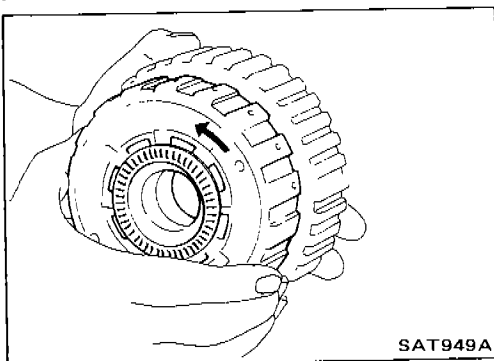

- g. Check that overrun clutch hub rotates as shown while holding forward clutch hub.

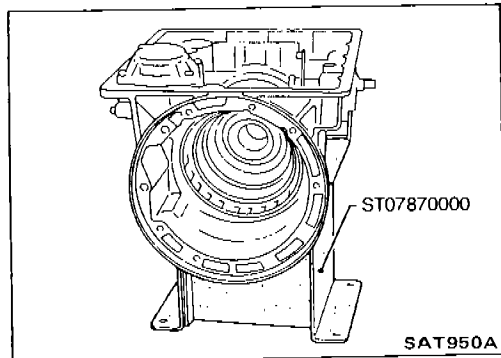

- h. Place transmission case into horizontal position.

ASSEMBLY

Assembly (Cont'd)

- i. Install rear internal gear, forward clutch hub and overrun clutch hub as a unit onto transmission case.

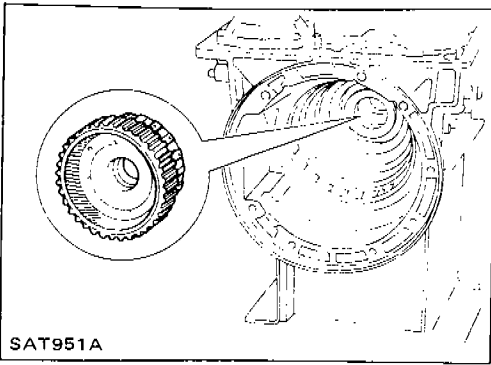

- j. Install needle bearing onto rear internal gear.
● Apply petroleum jelly to needle bearing.

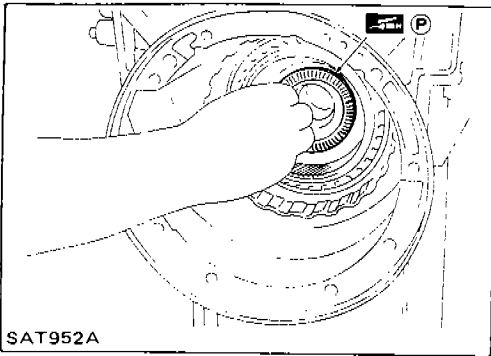

- k. Install bearing race onto rear of front internal gear.
● Apply petroleum jelly to bearing race.
● Securely engage pawls of bearing race with holes in front internal gear.

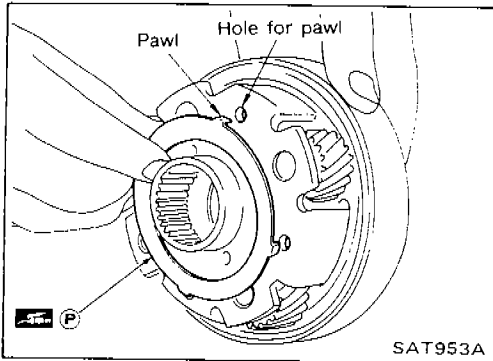

- l. Install front internal gear on transmission case.

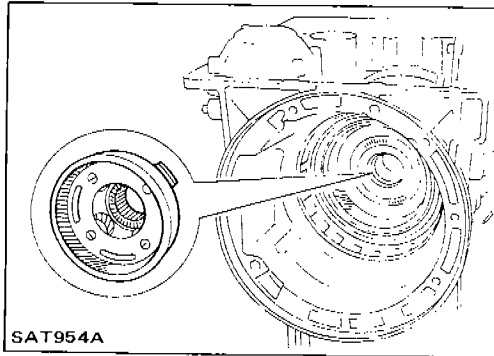

ASSEMBLY

Adjustment

When any parts listed in the following table are replaced, total end play or reverse clutch end play must be adjusted.

| Part name | Item | Total end play | Reverse clutch end play |
|-------------------------------|------|----------------|-------------------------|
| Transmission case | | • | • |
| Low one-way clutch inner race | | • | • |
| Overrun clutch hub | | • | • |
| Rear internal gear | | • | • |
| Rear planetary carrier | | • | • |
| Rear sun gear | | • | • |
| Front planetary carrier | | • | • |
| Front sun gear | | • | • |
| High clutch hub | | • | • |
| High clutch drum | | • | • |
| Oil pump cover | | • | • |
| Reverse clutch drum | | — | • |

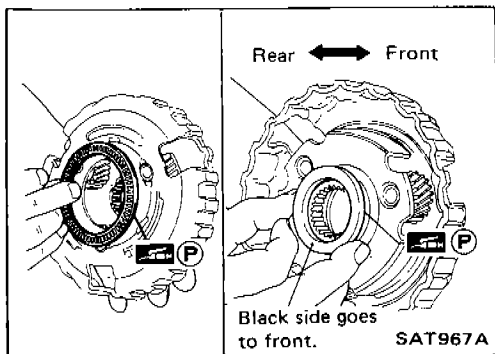
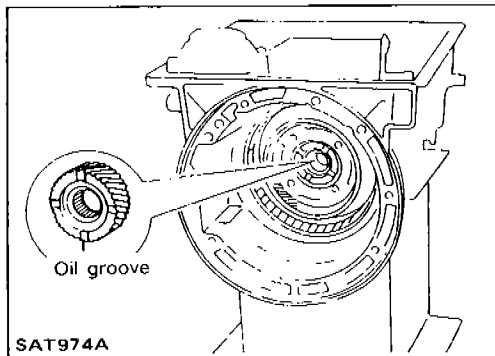

1. Install front side clutch and gear components.

a. Install rear sun gear on transmission case.

- Pay attention to its direction.

b. Install needle bearing on front of front planetary carrier.

- Apply petroleum jelly to needle bearing.

c. Install needle bearing on rear of front planetary carrier.

- Apply petroleum jelly to bearing.

- Pay attention to its direction — Black side goes to front.

ASSEMBLY

Adjustment (Cont'd)

- d. While rotating forward clutch drum clockwise, install front planetary carrier on forward clutch drum.

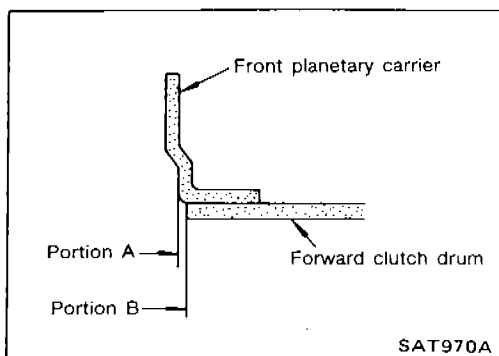
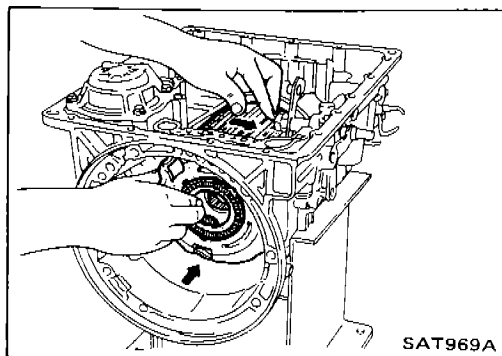

- Check that portion A of front planetary carrier protrudes approximately 2 mm (0.08 in) beyond portion B of forward clutch assembly.

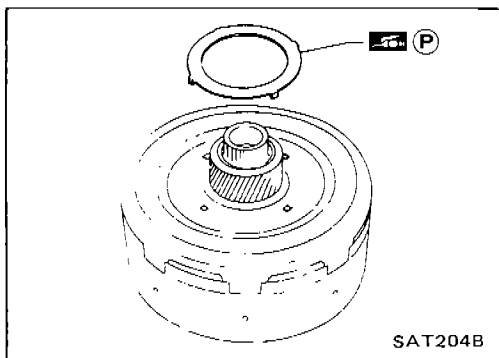

- e. Install bearing races on rear of clutch pack.
- Apply petroleum jelly to bearing races.
 - Securely engage pawls of bearing race with hole in clutch pack.

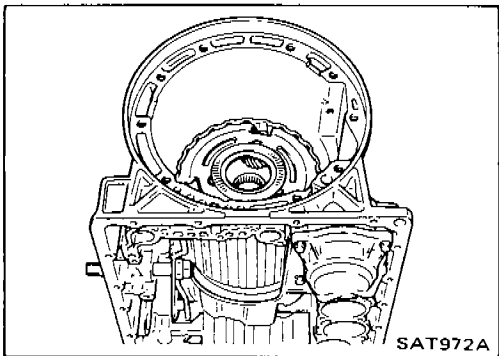

- f. Place transmission case in vertical position.

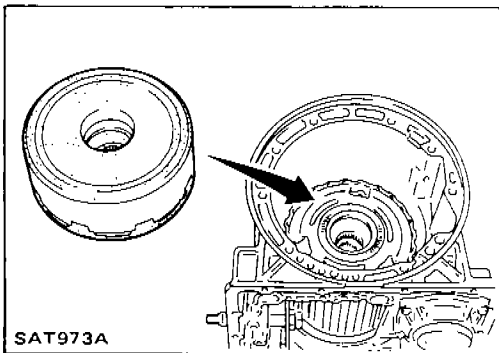

- g. Install clutch pack into transmission case.

ASSEMBLY

Adjustment (Cont'd)

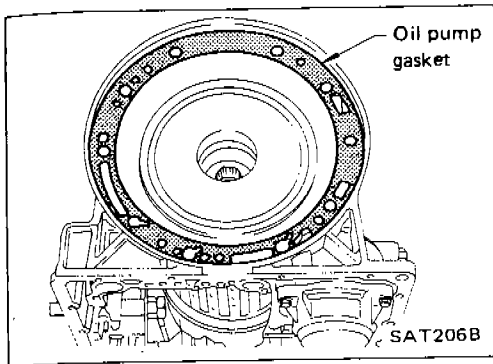

2. Adjust total end play.
 - a. Install new oil pump gasket on transmission case.

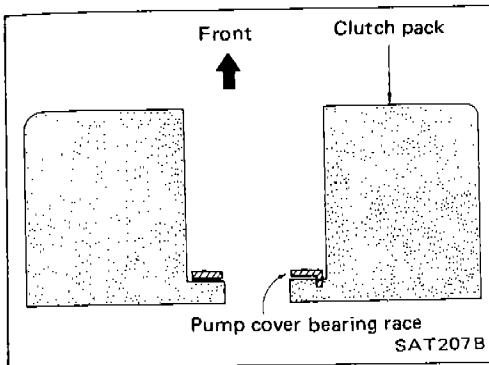

- b. Install pump cover bearing race on clutch pack.

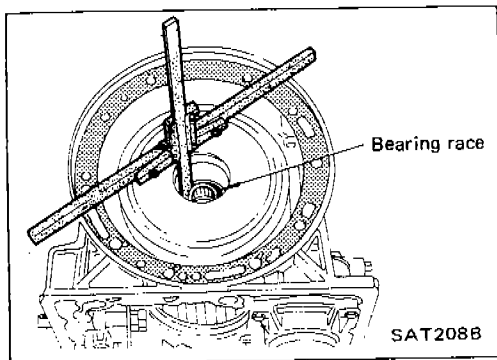

- c. Measure distance "B" between front end of transmission case and oil pump cover bearing race.

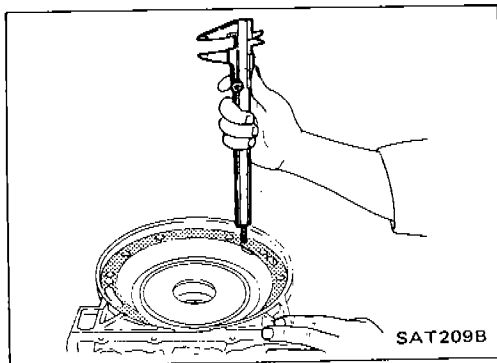

- d. Measure distance "C" between front end of transmission case and oil pump gasket.

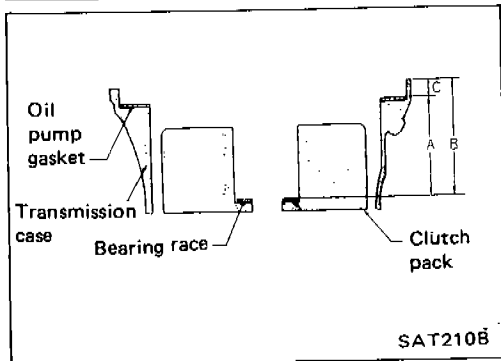

- e. Determine dimension "A" by using the following equation.

$$A = B - C$$

ASSEMBLY

Adjustment (Cont'd)

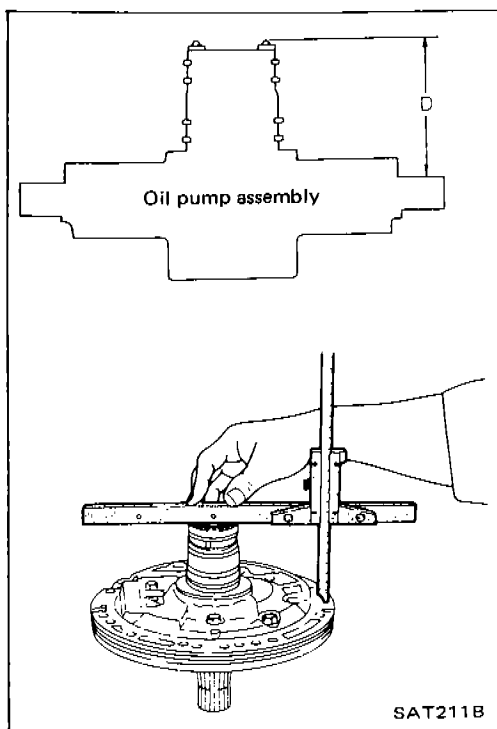

- f. Install needle bearing on oil pump assembly.
- g. Measure distance "D" between needle bearing and machined surface of oil pump cover assembly.

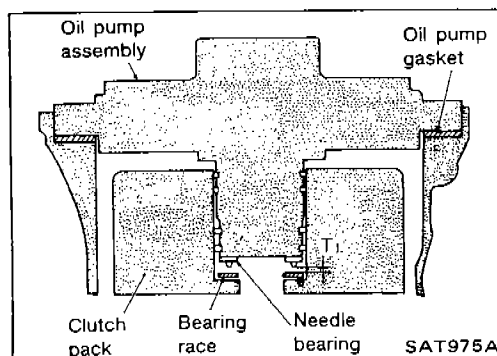

- h. Determine total end play "T₁" by using the following equation.

$$T_1 = A - D - 0.1$$

Total end play "T₁":

0.25 - 0.55 mm (0.0098 - 0.0217 in)

- If end play is out of specification, decrease or increase thickness of oil pump cover bearing race as necessary.

Available oil pump cover bearing race:

Refer to S.D.S.

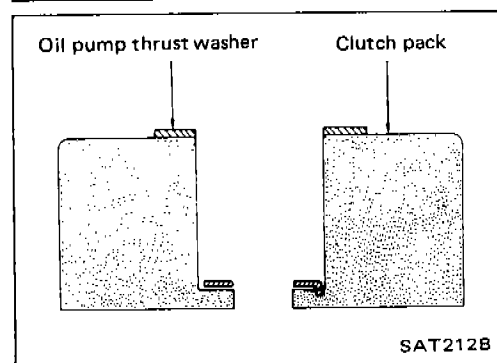

3. Adjust reverse clutch drum end play.
 - a. Install oil pump thrust washer on clutch pack.

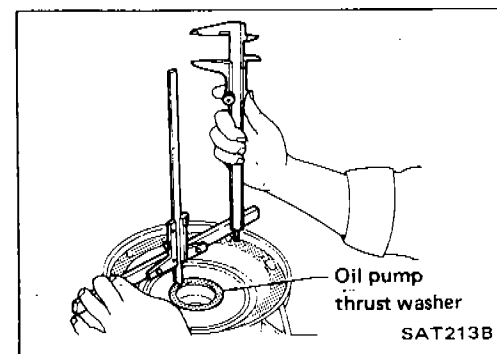

- b. Measure distance "F" between front end of transmission case and oil pump thrust washer.
 - c. Measure distance "G" between front end of transmission case and gasket.

ASSEMBLY

Adjustment (Cont'd)

d. Determine dimension "E" by using the following equation.

$$E = F - G$$

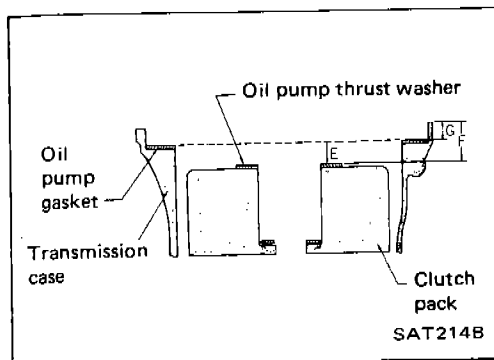

e. Measure distance "H".

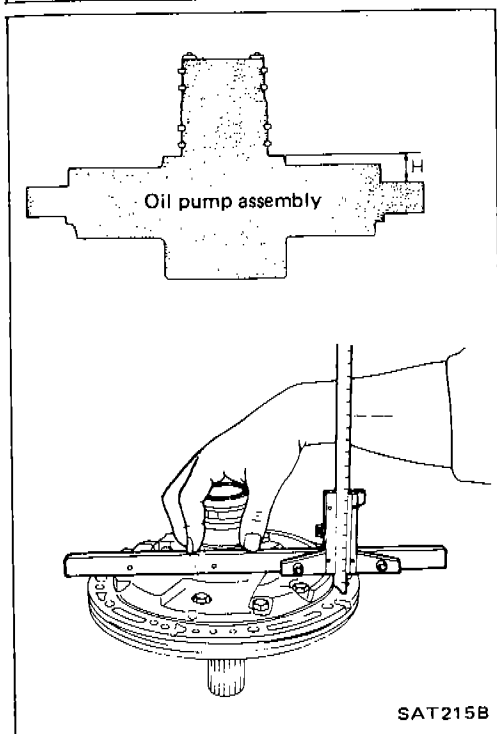

f. Determine reverse clutch drum end play "T₂" by using the following equation.

$$T_2 = E - H - 0.1$$

Reverse clutch drum end play "T₂":

0.55 - 0.90 mm (0.0217 - 0.0354 in)

- If end play is out of specification, decrease or increase thickness of oil pump thrust washer as necessary.

Available oil pump thrust washer:

Refer to S.D.S.

4. Remove any part installed to adjust end plays.

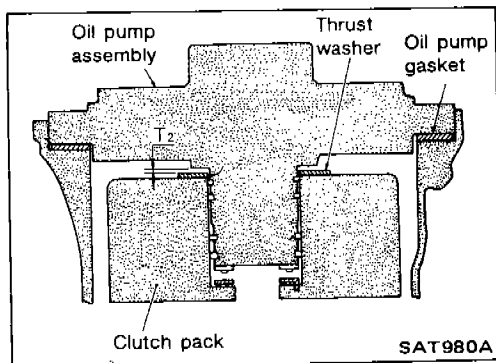

ASSEMBLY

Assembly

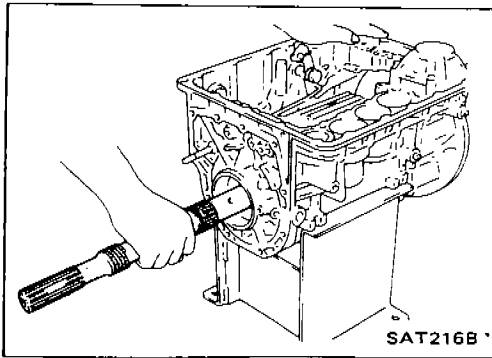

1. Install output shaft and parking gear.
 - a. Insert output shaft from rear of transmission case while slightly lifting front internal gear.
 - **Do not force output shaft against front of transmission case.**

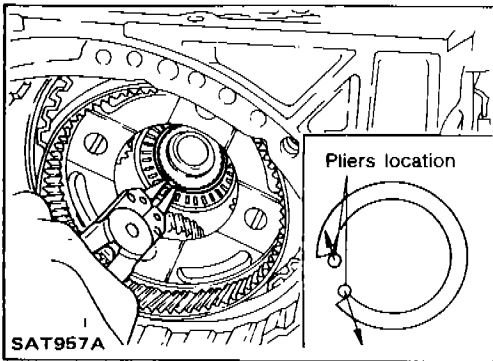

- b. Carefully push output shaft against front of transmission case. Install snap ring on front of output shaft.
 - **Check to be sure output shaft cannot be removed in rear direction.**

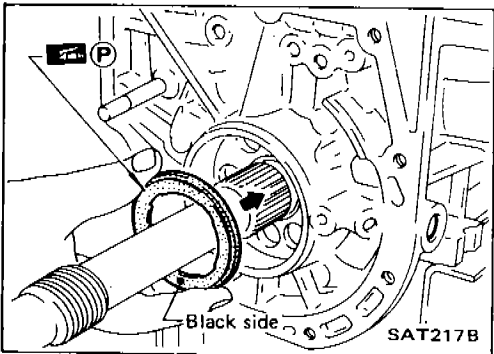

- c. Install needle bearing on transmission case.
 - **Pay attention to its direction — Black side goes to rear.**
 - **Apply petroleum jelly to needle bearing.**

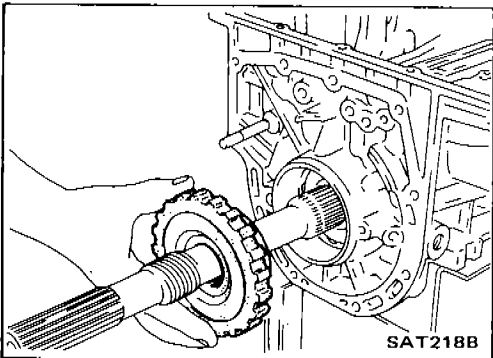

- d. Install parking gear on transmission case.

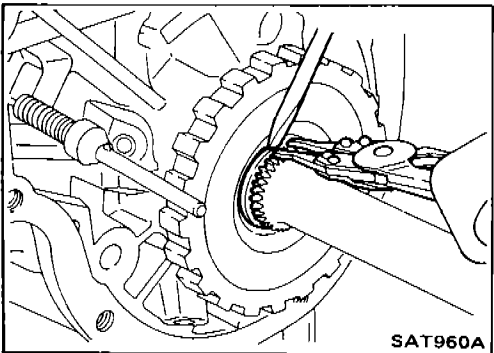

- e. Install snap ring on rear of output shaft.
 - **Check to be sure output shaft cannot be removed in forward direction.**

ASSEMBLY

Assembly (Cont'd)

2. Install rear extension.
 - a. Install oil seal on rear extension.
 - Apply A.T.F. to oil seal.

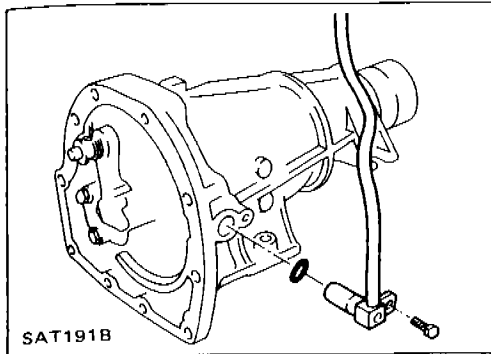
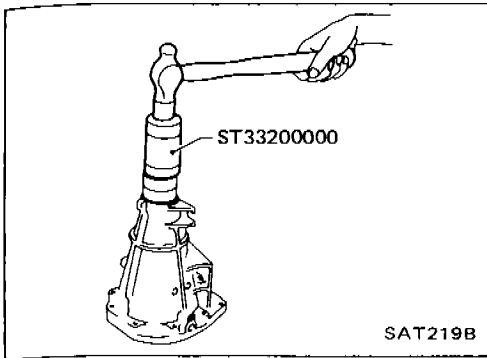

- b. Install O-ring on revolution sensor.
 - Apply A.T.F. to O-ring.
- c. Install revolution sensor on rear extension.

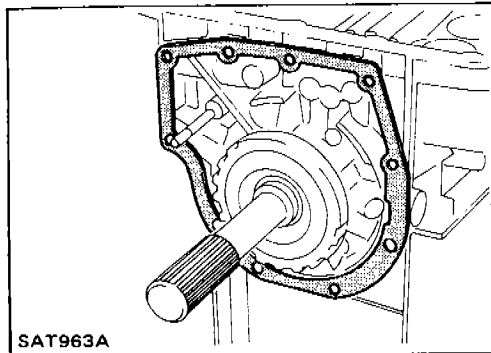

- d. Install rear extension gasket on transmission case.

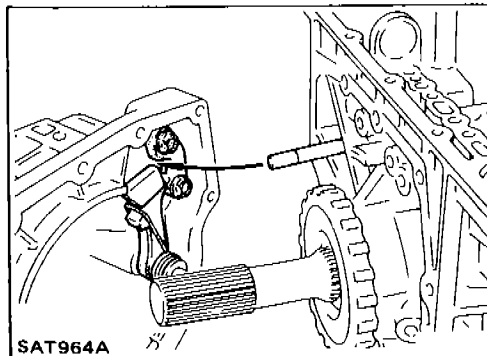

- e. Install parking rod on transmission case.

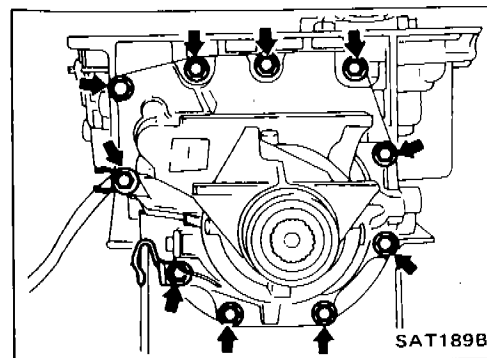

- f. Install rear extension on transmission case.

ASSEMBLY

Assembly (Cont'd)

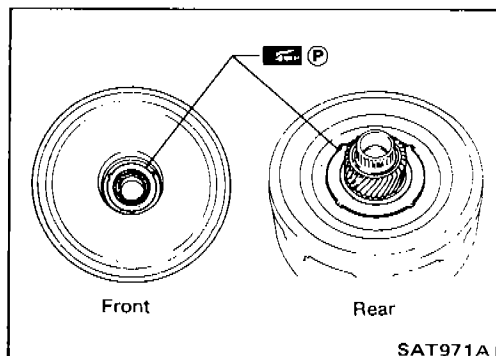
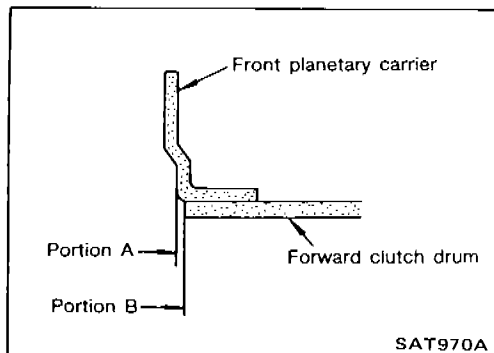
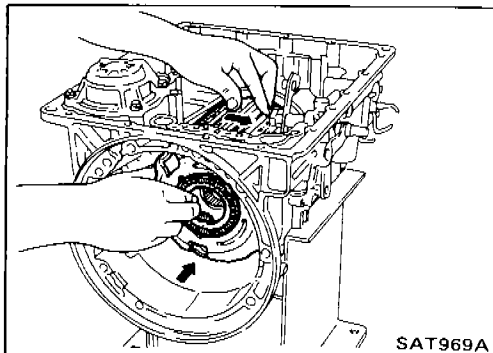
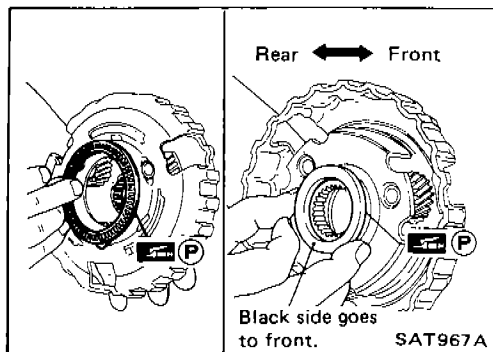
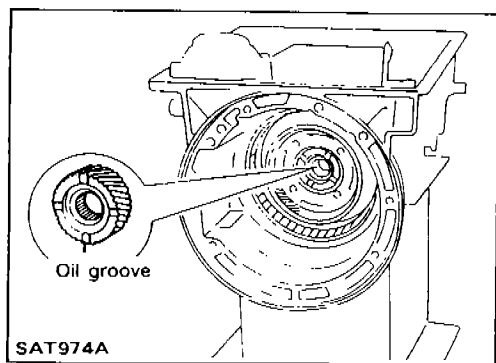

3. Install front side clutch and gear components.

a. Install rear sun gear on transmission case.

- Pay attention to its direction.

b. Make sure needle bearing is on front of front planetary carrier.

- Apply petroleum jelly to needle bearing.

c. Make sure needle bearing is on rear of front planetary carrier.

- Apply petroleum jelly to bearing.

- Pay attention to its direction — Black side goes to front.

d. While rotating forward clutch drum clockwise, install front planetary carrier on forward clutch drum.

- Check that portion A of front planetary carrier protrudes approximately 2 mm (0.08 in) beyond portion B of forward clutch assembly.

e. Make sure bearing races are on front and rear of clutch pack.

- Apply petroleum jelly to bearing races.

- Securely engage pawls of bearing races with holes in clutch pack.

ASSEMBLY

Assembly (Cont'd)

f. Install clutch pack into transmission case.

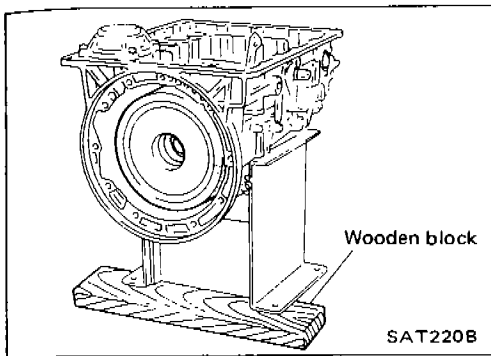

4. Install brake band and band strut.

a. Install band strut on brake band.

● Apply petroleum jelly to band strut.

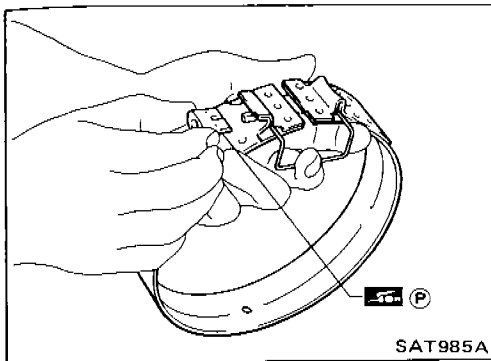

b. Place brake band on periphery of reverse clutch drum, and insert band strut into end of band servo piston stem.

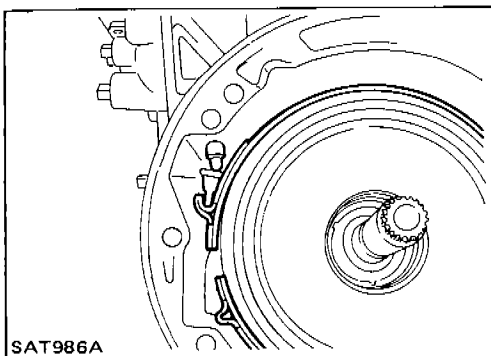

c. Install anchor end bolt on transmission case. Then, tighten anchor end bolt just enough so that reverse clutch drum (clutch pack) will not tilt forward.

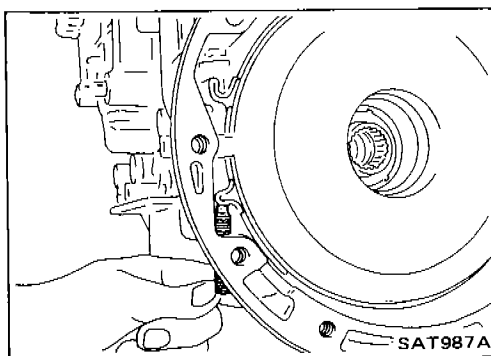

5. Install input shaft on transmission case.

● Pay attention to its direction — O-ring groove side is front.

6. Install gasket on transmission case.

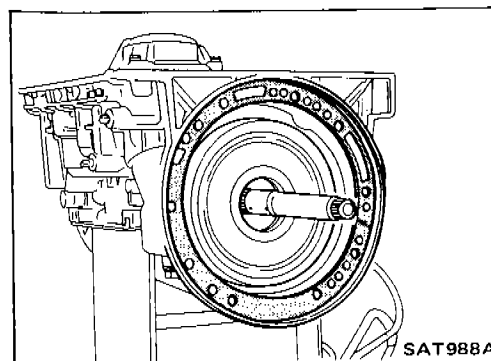

ASSEMBLY

Assembly (Cont'd)

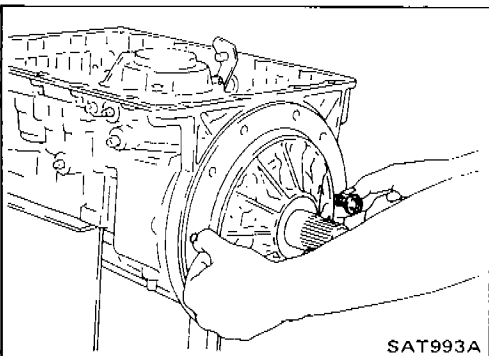
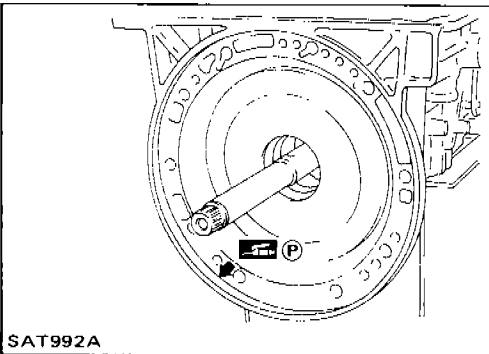
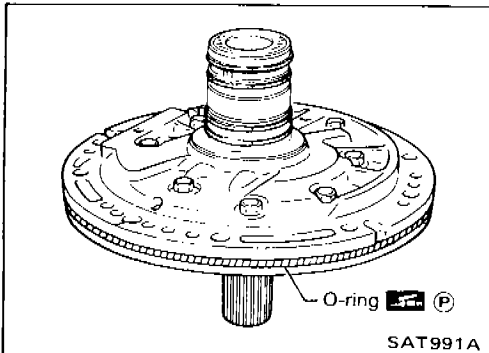
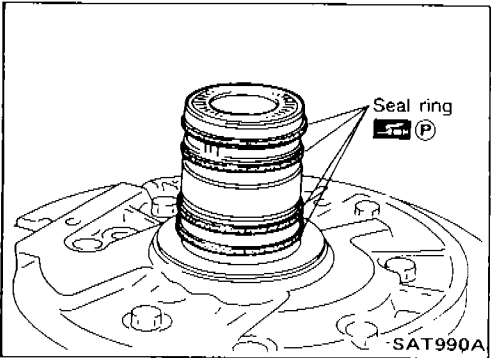
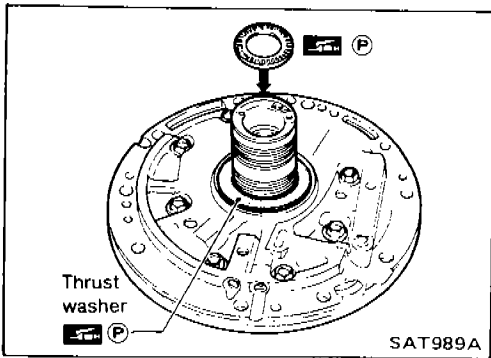

7. Install oil pump assembly.
 - a. Install needle bearing on oil pump assembly.
 - **Apply petroleum jelly to the needle bearing.**
 - b. Install selected thrust washer on oil pump assembly.
 - **Apply petroleum jelly to thrust washer.**

- c. Carefully install seal rings into grooves and press them into the petroleum jelly so that they are a tight fit.

- d. Install O-ring on oil pump assembly.
 - **Apply petroleum jelly to O-ring.**

- e. Apply petroleum jelly to mating surface of transmission case and oil pump assembly.

- f. Install oil pump assembly.
 - **Install two converter housing securing bolts in bolt holes in oil pump assembly as guides.**

ASSEMBLY

Assembly (Cont'd)

- Insert oil pump assembly to the specified position in transmission, as shown at left.

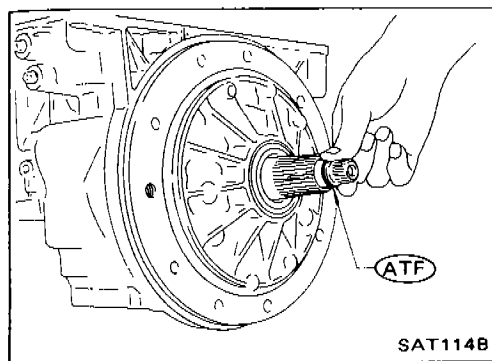
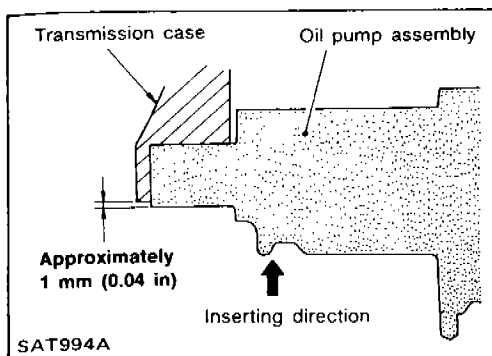

8. Install O-ring on input shaft.
- Apply A.T.F. to O-rings.

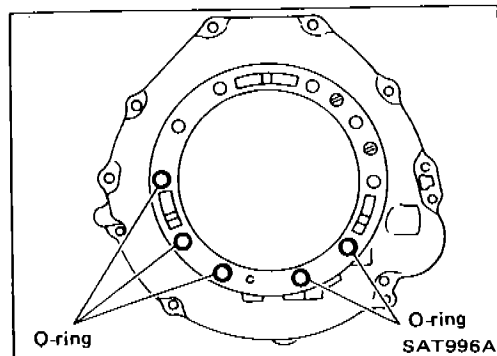

9. Install converter housing.
- a. Install O-rings on converter housing.

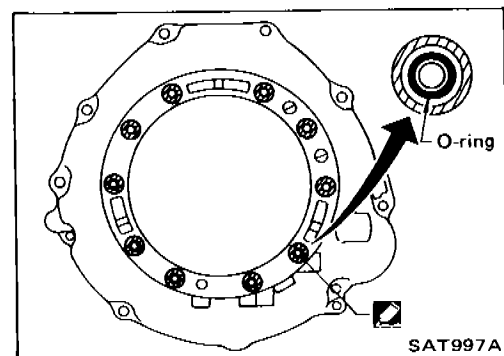

- b. Apply recommended sealant (Nissan genuine part: KP610-00250 or equivalent) to outer periphery of bolt holes in converter housing.
- Do not apply too much sealant.

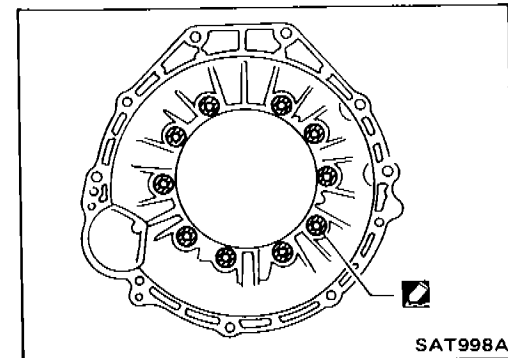

- c. Apply recommended sealant (Nissan genuine part: KP610-00250 or equivalent) to seating surfaces of bolts that secure front of converter housing.

ASSEMBLY

Assembly (Cont'd)

d. Install converter housing on transmission case.

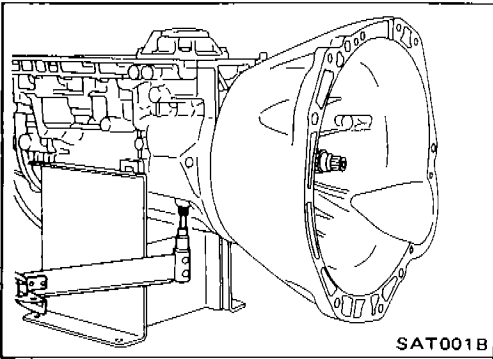
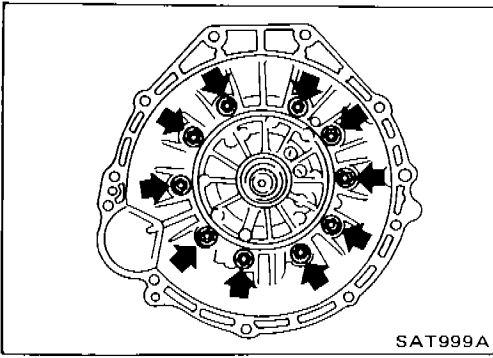

10. Adjust brake band.

a. Tighten anchor end bolt to specified torque.

Anchor end bolt:

: 4 - 6 N·m

(0.4 - 0.6 kg-m, 2.9 - 4.3 ft-lb)

b. Back off anchor end bolt two and a half turns.

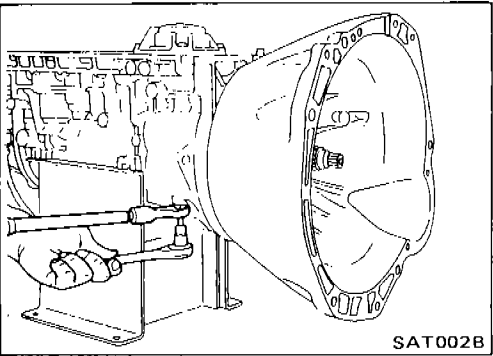

c. While holding anchor end pin, tighten lock nut.

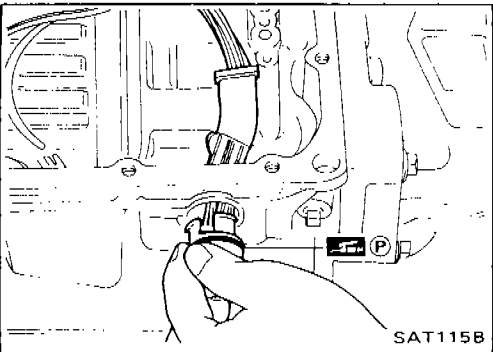

11. Install terminal cord assembly.

a. Install O-ring on terminal cord assembly.

● **Apply petroleum jelly to O-ring.**

b. Compress terminal cord assembly stopper and install terminal cord assembly on transmission case.

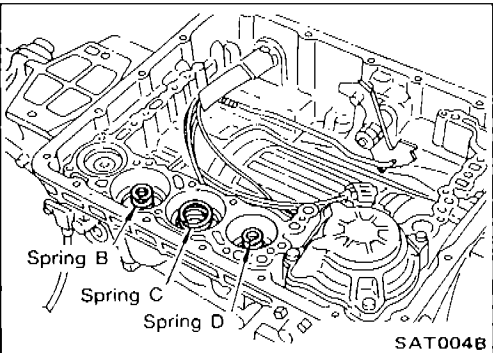

12. Install control valve assembly.

a. Install accumulator piston return springs B, C and D.

Free length of return springs:

Unit: mm (in)

| Item | Accumulator | B | C | D |
|-------------|-------------|-----------|-----------|--------------|
| Free length | | 66 (2.60) | 45 (1.77) | 58.4 (2.299) |

ASSEMBLY

Assembly (Cont'd)

- b. Install manual valve on control valve.
 ● Apply A.T.F. to manual valve.

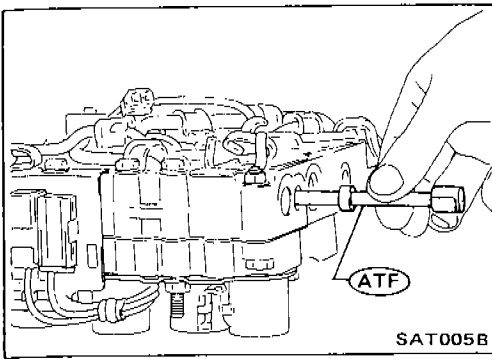

- c. Place control valve assembly on transmission case. Connect solenoid connector for upper body.
 d. Install connector clip.

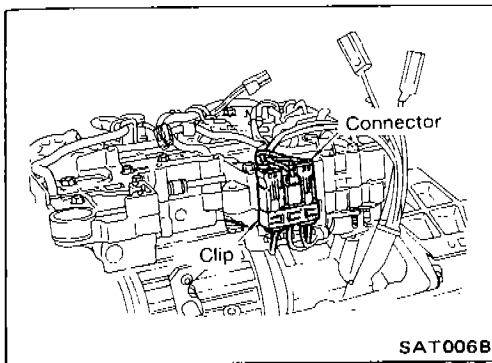

- e. Install control valve assembly on transmission case.
 f. Install connector tube brackets and tighten bolts (A) and (B).
 ● Check that terminal assembly harness does not catch.

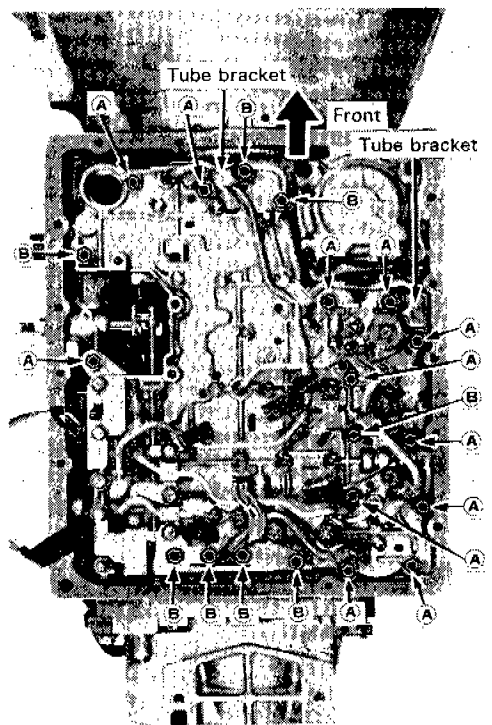

| Bolt symbol | ℓ mm (in) |  ℓ |
|-------------|-----------|----------------------------------------------------------------------------------------|
| (A) | 33 (1.30) | |
| (B) | 45 (1.77) | |

- g. Install O-ring on oil strainer.
 ● Apply petroleum jelly to O-ring.
 h. Install oil strainer on control valve.

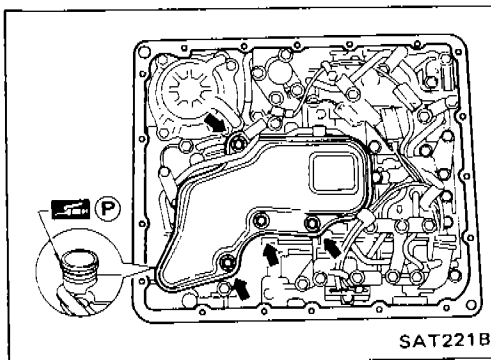

ASSEMBLY

Assembly (Cont'd)

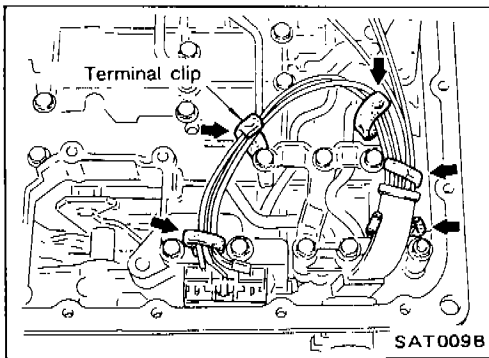

- i. Securely fasten terminal harness with clips.

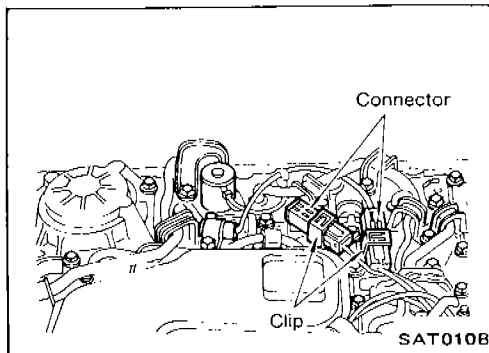

- j. Install lock-up solenoid and fluid temperature sensor connectors.

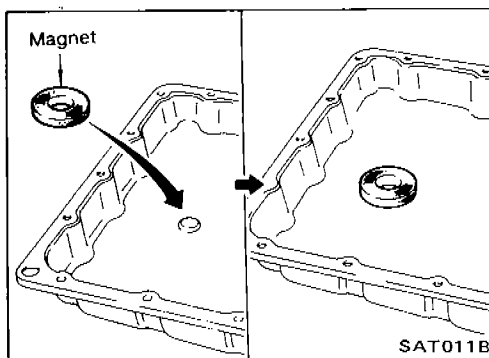

13. Install oil pan.

- a. Attach a magnet to oil pan.

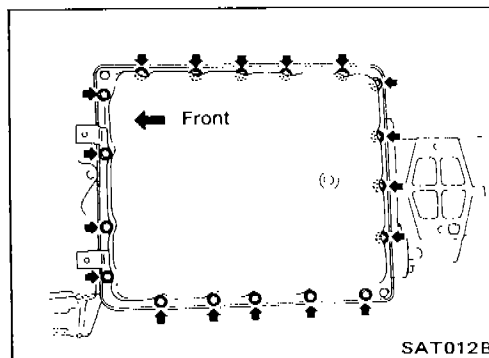

- b. Install oil pan gasket on transmission case.

- c. Install oil pan and bracket on transmission case.

- Tighten four bolts in a criss-cross pattern to prevent dislocation of gasket.

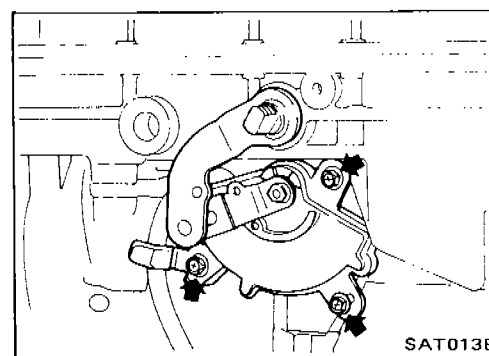

14. Install inhibitor switch.

- a. Check that manual shaft is in "1" range.

- b. Temporarily install inhibitor switch on manual shaft.

- c. Move manual shaft to "N".

ASSEMBLY

Assembly (Cont'd)

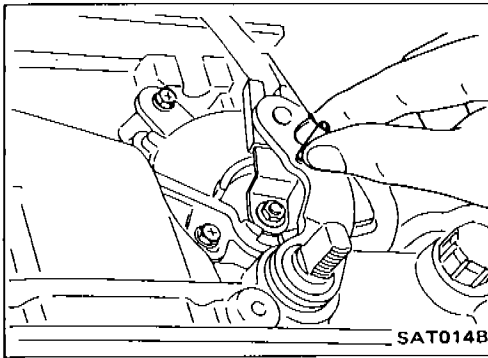

- d. Tighten bolts while inserting 4.0 mm (0.157 in) dia. pin vertically into locating holes in inhibitor switch and manual shaft.

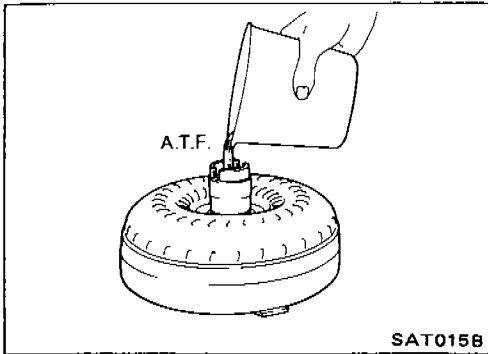

15. Install torque converter.

- a. Pour A.T.F. into torque converter.

- Approximately 2 liters (1-3/4 Imp qt) of fluid are required for a new torque converter.
- When reusing old torque converter, add the same amount of fluid as was drained.

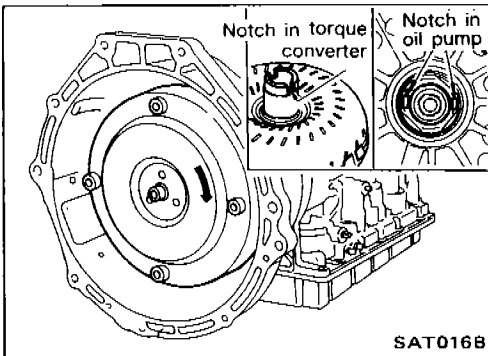

- b. Install torque converter while aligning notches and oil pump.

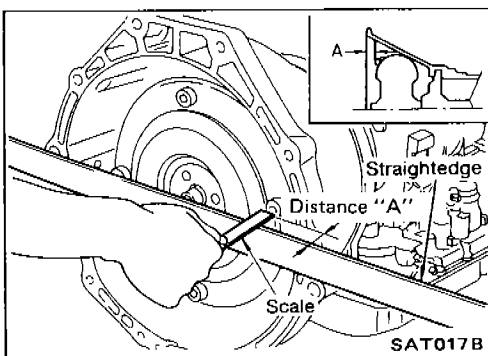

- c. Measure distance A to check that torque converter is in proper position.

Distance "A":

23.5 mm (0.925 in) or more

SERVICE DATA AND SPECIFICATIONS (S.D.S.)

General Specifications

| | |
|--------------------------------|-------------------------------------------|
| Engine | CA18DET |
| Automatic transmission model | RE4R01A |
| Transmission model code number | 41X71 |
| Stall torque ratio | 2.0 : 1 |
| Transmission gear ratio | |
| 1st | 3.027 |
| 2nd | 1.619 |
| Top | 1.000 |
| O.D. | 0.694 |
| Reverse | 2.272 |
| Recommended oil | Automatic transmission fluid Type DEXRON™ |
| Oil capacity ℓ (Imp qt) | 7.9 (7) |

Specifications and Adjustment

VEHICLE SPEED WHEN SHIFTING GEARS

Europe

| Throttle position | Vehicle speed km/h (MPH) | | | | | | |
|-------------------|---------------------------------|---------------------------------|---------------------------------|---------------------------------|---------------------------------|---------------------------------|---------------------------------|
| | D ₁ → D ₂ | D ₂ → D ₃ | D ₃ → D ₄ | D ₄ → D ₃ | D ₃ → D ₂ | D ₂ → D ₁ | 1 ₂ → 1 ₁ |
| Full throttle | 58 - 62 (36 - 39) | 109 - 115 (68 - 71) | 176 - 186 (109 - 116) | 170 - 180 (106 - 112) | 104 - 110 (65 - 68) | 44 - 48 (27 - 30) | 53 - 57 (33 - 35) |
| Half throttle | 41 - 45 (25 - 28) | 78 - 84 (48 - 52) | 125 - 135 (78 - 84) | 74 - 84 (46 - 52) | 29 - 35 (18 - 22) | 10 - 14 (6 - 9) | 53 - 57 (33 - 35) |

Except Europe

| Throttle position | Vehicle speed km/h (MPH) | | | | | | |
|-------------------|---------------------------------|---------------------------------|---------------------------------|---------------------------------|---------------------------------|---------------------------------|---------------------------------|
| | D ₁ → D ₂ | D ₂ → D ₃ | D ₃ → D ₄ | D ₄ → D ₃ | D ₃ → D ₂ | D ₂ → D ₁ | 1 ₂ → 1 ₁ |
| Full throttle | 54 - 58 (34 - 36) | 101 - 107 (63 - 66) | 164 - 174 (102 - 108) | 158 - 168 (98 - 104) | 95 - 101 (59 - 63) | 44 - 48 (27 - 30) | 53 - 57 (33 - 35) |
| Half throttle | 41 - 45 (25 - 28) | 73 - 79 (45 - 49) | 119 - 129 (74 - 80) | 78 - 88 (48 - 55) | 34 - 40 (21 - 25) | 10 - 14 (6 - 9) | 53 - 57 (33 - 35) |

SERVICE DATA AND SPECIFICATIONS (S.D.S.)

Specifications and Adjustment (Cont'd)

VEHICLE SPEED WHEN PERFORMING AND RELEASING LOCK-UP

Europe

| Throttle position | D ₄ | |
|-------------------|--------------------------|--------------------------|
| | Vehicle speed km/h (MPH) | |
| | Lock-up "ON" | Lock-up "OFF" |
| Full throttle | 176 - 186 (109 - 116) | 170 - 180 (106 - 112) |
| Half throttle | 126 - 134 (78 - 83) | 110 - 118 (68 - 73) |

Except Europe

| Throttle position | D ₄ | |
|-------------------|--------------------------|-------------------------|
| | Vehicle speed km/h (MPH) | |
| | Lock-up "ON" | Lock-up "OFF" |
| Full throttle | 164 - 174 (102 - 108) | 158 - 168 (98 - 104) |
| Half throttle | 120 - 128 (75 - 80) | 102 - 110 (63 - 68) |

STALL REVOLUTION

| Stall revolution rpm |
|----------------------|
| 3,050 - 3,250 |

LINE PRESSURE

| Engine speed rpm | Line pressure kPa (bar, kg/cm ² , psi) | |
|------------------|-------------------------------------------------------------|-------------------------------------------------------------|
| | D, 2 and 1 ranges | R range |
| Idle | 471 - 510 (4.71 - 5.10, 4.8 - 5.2, 68 - 74) | 657 - 696 (6.57 - 6.96, 6.7 - 7.1, 95 - 101) |
| Stall | 1,020 - 1,098 (10.20 - 10.98, 10.4 - 11.2, 148 - 159) | 1,422 - 1,500 (14.22 - 15.00, 14.5 - 15.3, 206 - 218) |

SERVICE DATA AND SPECIFICATIONS (S.D.S.)

Specifications and Adjustment (Cont'd)

RETURN SPRINGS

Unit: mm (in)

| Parts | Item | Part No. | Free length | Outer diameter | |
|---------------------------------|---------------|--------------------------------------|----------------|----------------|---------------|
| Control valve | Upper body | Torque converter relief valve spring | 31742-41X18 | 32.3 (1.272) | 9.0 (0.354) |
| | | Pressure regulator valve spring | 31742-41X16 | 61.5 (2.421) | 8.9 (0.350) |
| | | Pressure modifier valve spring | 31742-41X19 | 31.95 (1.2579) | 6.8 (0.268) |
| | | Shuttle shift valve D spring | 31762-41X00 | 26.5 (1.043) | 6.0 (0.236) |
| | | 4-2 sequence valve spring | 31756-41X00 | 29.1 (1.146) | 6.95 (0.2736) |
| | | Shift valve B spring | 31762-41X01 | 25.0 (0.984) | 7.0 (0.276) |
| | | 4-2 relay valve spring | 31756-41X00 | 29.1 (1.146) | 6.95 (0.2736) |
| | | Shift valve A spring | 31762-41X01 | 25.0 (0.984) | 7.0 (0.276) |
| | | Overrun clutch control valve spring | 31762-41X03 | 23.6 (0.929) | 7.0 (0.276) |
| | | Overrun clutch reducing valve spring | 31742-41X14 | 38.9 (1.531) | 7.0 (0.276) |
| | | Shuttle shift valve S spring | 31762-41X04 | 51.0 (2.008) | 5.65 (0.2224) |
| | | Pilot valve spring | 31742-41X13 | 25.7 (1.012) | 9.1 (0.358) |
| | | Lock-up control valve spring | 31742-41X22 | 18.5 (0.728) | 13.0 (0.512) |
| | Lower body | Modifier accumulator piston spring | 31742-41X15 | 30.5 (1.201) | 9.8 (0.386) |
| | | 1st reducing valve spring | 31756-41X05 | 25.4 (1.000) | 6.75 (0.2657) |
| 3-2 timing valve spring | | 31742-41X08 | 20.55 (0.8091) | 6.75 (0.2657) | |
| Servo charger valve spring | | 31742-41X06 | 23.0 (0.906) | 6.7 (0.264) | |
| Reverse clutch | 16 pcs | 30505-41X02 | 19.69 (0.7752) | 11.6 (0.457) | |
| High clutch | 16 pcs | 31505-21X03 | 22.06 (0.8685) | 11.6 (0.457) | |
| Forward clutch (Overrun clutch) | 20 pcs | 31505-41X01 | 35.77 (1.4083) | 9.7 (0.382) | |
| Low & reverse brake | 18 pcs | 31521-21X00 | 23.7 (0.933) | 11.6 (0.457) | |
| Band servo | Spring A | 31605-41X05 | 45.6 (1.795) | 34.3 (1.350) | |
| | Spring B | 31605-41X00 | 53.8 (2.118) | 40.3 (1.587) | |
| | Spring C | 31605-41X01 | 29.0 (1.142) | 27.6 (1.087) | |
| Accumulator | Accumulator A | 31605-41X02 | 43.0 (1.693) | | |
| | Accumulator B | 31605-41X10 | 66.0 (2.598) | | |
| | Accumulator C | 31605-41X09 | 45.0 (1.772) | | |
| | Accumulator D | 31605-41X06 | 58.4 (2.299) | | |

SERVICE DATA AND SPECIFICATIONS (S.D.S.)

Specifications and Adjustment (Cont'd)

ACCUMULATOR O-RING

| Accumulator | Diameter mm (in) | | | |
|--------------------|------------------|-----------|-----------|-----------|
| | A | B | C | D |
| Small diameter end | 29 (1.14) | 32 (1.26) | 45 (1.77) | 29 (1.14) |
| Large diameter end | 45 (1.77) | 50 (1.97) | 50 (1.97) | 45 (1.77) |

CLUTCHES AND BRAKES

| Reverse clutch | | |
|-------------------------------------|---------------------------|-------------|
| Number of drive plates | 2 | |
| Number of driven plates | 2 | |
| Thickness of drive plate mm (in) | | |
| Standard | 2.0 (0.079) | |
| Wear limit | 1.8 (0.071) | |
| Clearance mm (in) | | |
| Standard | 0.5 - 0.8 (0.020 - 0.031) | |
| Allowable limit | 1.2 (0.047) | |
| Thickness of retaining plate | Thickness mm (in) | Part number |
| | 4.6 (0.181) | 31537-21X00 |
| | 4.8 (0.189) | 31537-21X01 |
| | 5.0 (0.197) | 31537-21X02 |
| | 5.2 (0.205) | 31537-21X03 |
| | 5.4 (0.213) | 31537-21X04 |
| | 5.6 (0.220) | 31567-41X13 |
| | 5.8 (0.228) | 31567-41X14 |
| High clutch | | |
| Number of drive plates | 5 | |
| Number of driven plates | 5 | |
| Thickness of drive plate mm (in) | | |
| Standard | 1.6 (0.063) | |
| Wear limit | 1.4 (0.055) | |
| Clearance mm (in) | | |
| Standard | 1.8 - 2.2 (0.071 - 0.087) | |
| Allowable limit | 3.2 (0.126) | |
| Thickness of retaining plate | Thickness mm (in) | Part number |
| | 3.4 (0.134) | 31537-41X71 |
| | 3.6 (0.142) | 31537-41X61 |
| | 3.8 (0.150) | 31537-41X62 |
| | 4.0 (0.157) | 31537-41X63 |
| | 4.2 (0.165) | 31537-41X64 |
| | 4.4 (0.173) | 31537-41X65 |
| | 4.6 (0.181) | 31537-41X66 |
| 4.8 (0.189) | 31537-41X67 | |

| Forward clutch | | |
|-------------------------------------|-------------------------------|-------------|
| Number of drive plates | 5 | |
| Number of driven plates | 5 | |
| Thickness of drive plate mm (in) | | |
| Standard | 2.0 (0.079) | |
| Wear limit | 1.8 (0.071) | |
| Clearance mm (in) | | |
| Standard | 0.45 - 0.85 (0.0177 - 0.0335) | |
| Allowable limit | 2.05 (0.0807) | |
| Thickness of retaining plate | Thickness mm (in) | Part number |
| | 4.0 (0.157) | 31537-41X07 |
| | 4.2 (0.165) | 31537-41X08 |
| | 4.4 (0.173) | 31537-41X09 |
| | 4.6 (0.181) | 31537-41X10 |
| | 4.8 (0.189) | 31537-41X11 |
| | 5.0 (0.197) | 31537-41X12 |
| | 5.2 (0.205) | 31537-41X13 |
| Overrun clutch | | |
| Number of drive plates | 3 | |
| Number of driven plates | 5 | |
| Thickness of drive plate mm (in) | | |
| Standard | 2.0 (0.079) | |
| Wear limit | 1.8 (0.071) | |
| Clearance mm (in) | | |
| Standard | 1.0 - 1.4 (0.039 - 0.055) | |
| Allowable limit | 2.0 (0.079) | |
| Thickness of retaining plate | Thickness mm (in) | Part number |
| | 4.0 (0.157) | 31537-41X79 |
| | 4.2 (0.165) | 31537-41X80 |
| | 4.4 (0.173) | 31537-41X81 |
| | 4.6 (0.181) | 31537-41X82 |
| | 4.8 (0.189) | 31537-41X83 |
| | 5.0 (0.197) | 31537-41X84 |
| | 5.2 (0.205) | 31537-41X20 |

SERVICE DATA AND SPECIFICATIONS (S.D.S.)

Specifications and Adjustment (Cont'd)

| | | |
|-----------------------------------------------------------|---------------------------------|-------------|
| Low & reverse brake | | |
| Number of drive plates | 6 | |
| Number of driven plates | 6 | |
| Thickness of drive plate mm (in) | | |
| Standard | 2.0 (0.079) | |
| Wear limit | 1.8 (0.071) | |
| Clearance mm (in) | | |
| Standard | 1.1 - 1.5 (0.043 - 0.059) | |
| Allowable limit | 2.5 (0.098) | |
| Thickness of retaining plate | Thickness mm (in) | Part number |
| | 8.6 (0.339) | 31667-41X03 |
| | 8.8 (0.346) | 31667-41X04 |
| | 9.0 (0.354) | 31667-41X05 |
| | 9.2 (0.362) | 31667-41X06 |
| | 9.4 (0.370) | 31667-41X09 |
| 9.6 (0.378) | 31667-41X10 | |
| Brake band | | |
| Anchor end bolt tightening torque N·m (kg-m, ft-lb) | 4 - 6 (0.4 - 0.6, 2.9 - 4.3) | |
| Number of returning revolutions for anchor end bolt | 2.5 | |

REVERSE CLUTCH DRUM END PLAY

| | | |
|---------------------------------------------------|----------------------------------------|-------------|
| Reverse clutch drum end play "T ₂ " | 0.55 - 0.90 mm (0.0217 - 0.0354 in) | |
| Thickness of oil pump thrust washer | Thickness mm (in) | Part number |
| | 0.7 (0.028) | 31528-21X00 |
| | 0.9 (0.035) | 31528-21X01 |
| | 1.1 (0.043) | 31528-21X02 |
| | 1.3 (0.051) | 31528-21X03 |
| | 1.5 (0.059) | 31528-21X04 |
| | 1.7 (0.067) | 31528-21X05 |
| 1.9 (0.075) | 31528-21X06 | |

REMOVAL AND INSTALLATION

| | |
|---------------------------------------------------------------------------|-----------------------------------------------|
| Manual control linkage Number of returning revolutions for lock nut | 1 |
| Lock nut tightening torque | 11 - 15 N·m (1.1 - 1.5 kg-m, 8 - 11 ft-lb) |
| Distance between end of clutch housing and torque converter | 26.0 mm (1.024 in) or more |
| Drive plate runout limit | 0.5 mm (0.020 in) |

OIL PUMP AND LOW ONE-WAY CLUTCH

| | |
|-------------------------------------------------------------------|--------------------------------|
| Oil pump clearance mm (in) | |
| Cam ring - oil pump housing Standard | 0.01 - 0.024 (0.0004 - 0.0009) |
| Rotor, vanes and control piston - oil pump housing Standard | 0.03 - 0.044 (0.0012 - 0.0017) |
| Seal ring clearance mm (in) | |
| Standard | 0.10 - 0.25 (0.0039 - 0.0098) |
| Allowable limit | 0.25 (0.0098) |

TOTAL END PLAY

| | | |
|---------------------------------------------|----------------------------------------|-------------|
| Total end play "T ₁ " | 0.25 - 0.55 mm (0.0098 - 0.0217 in) | |
| Thickness of oil pump cover bearing race | Thickness mm (in) | Part number |
| | 0.8 (0.031) | 31429-21X00 |
| | 1.0 (0.039) | 31429-21X01 |
| | 1.2 (0.047) | 31429-21X02 |
| | 1.4 (0.055) | 31429-21X03 |
| | 1.6 (0.063) | 31429-21X04 |
| | 1.8 (0.071) | 31429-21X05 |
| 2.0 (0.079) | 31429-21X06 | |

PROPELLER SHAFT & DIFFERENTIAL CARRIER

SECTION **PD**



CONTENTS

| | |
|------------------------------------------------|-------|
| PREPARATION | PD- 2 |
| PROPELLER SHAFT | PD- 4 |
| ON-VEHICLE SERVICE (Final drive) | PD- 8 |
| REMOVAL AND INSTALLATION | PD-10 |
| FINAL DRIVE | PD-11 |
| DISASSEMBLY | PD-12 |
| INSPECTION | PD-16 |
| ADJUSTMENT | PD-17 |
| ASSEMBLY | PD-24 |
| DIFFERENTIAL GEAR OIL COOLER SYSTEM | PD-29 |
| SERVICE DATA AND SPECIFICATIONS (S.D.S.) | PD-33 |

PD

PREPARATION

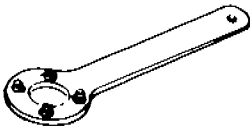
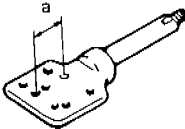
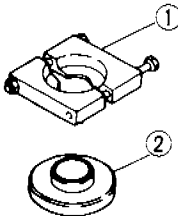
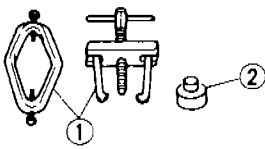
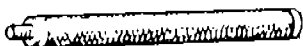
SPECIAL SERVICE TOOLS

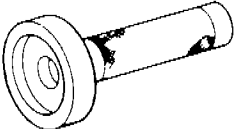
| Tool number Tool name | Description | |
|---------------------------------------------------------------------------------------------------------|------------------------------------------------------------------------------------------------------------------------------------------|------------------------------------------------------------------------------|
| ST38060002 Drive pinion flange wrench |  | Removing and installing propeller shaft lock nut, and drive pinion lock nut. |
| KV38100800 Differential attachment |  <p style="text-align: center;">a: 152 mm (5.98 in)</p> | Mounting final drive (To use, make a new hole.) |
| ST3090S000 Drive pinion rear inner race puller set ① ST30031000 Puller ② ST30901000 Base |  | Removing and installing drive pinion rear cone |
| ST3306S001 Differential side bearing puller set ① ST33051001 Body ② ST33061000 Adapter |  | Removing and installing differential side bearing inner cone |
| ST30611000 Drift |  | Installing pinion rear bearing outer race |
| ST30613000 Drift |  | Installing pinion rear bearing outer race |
| ST30701000 Drift |  | Installing pinion front bearing outer race |
| KV38100200 Gear carrier side oil seal drift |  | Installing side oil seal |

PREPARATION

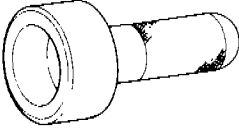
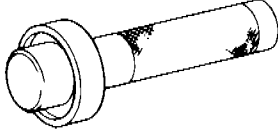
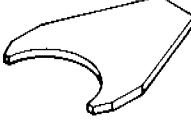
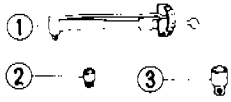
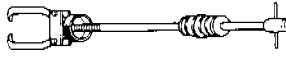
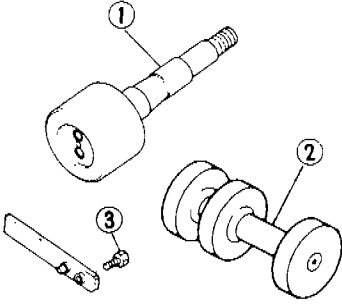
| Tool number Tool name | Description |
|---------------------------------------------------------------------------------------------------------------------------------------|----------------------------------------------------------------------------------------------------------------------------------------------------------------------------|
| KV38100500 Gear carrier front oil seal drift |  <p style="text-align: right;">Installing front oil seal</p> |
| KV38100300 Differential side bearing inner cone |  <p style="text-align: right;">Installing side bearing inner cone</p> |
| KV38100600 Side bearing spacer drift |  <p style="text-align: right;">Installing side bearing spacer</p> |
| ST3127S000 Preload gauge ① GG91030000 Torque wrench ② HT62940000 Socket adapter ③ HT62900000 Socket adapter |  <p style="text-align: right;">Measuring pinion bearing preload and total preload</p> |
| HT72400000 Slide hammer |  <p style="text-align: right;">Removing differential case assembly</p> |
| KV381039S0 Drive pinion setting gauge ① KV38103910 Dummy shaft ② KV38100120 Height gauge ③ KV38100140 Stopper |  <p style="text-align: right;">Selecting pinion height adjusting washer</p> |

PROPELLER SHAFT

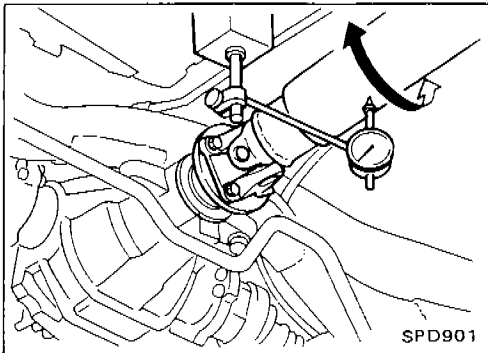
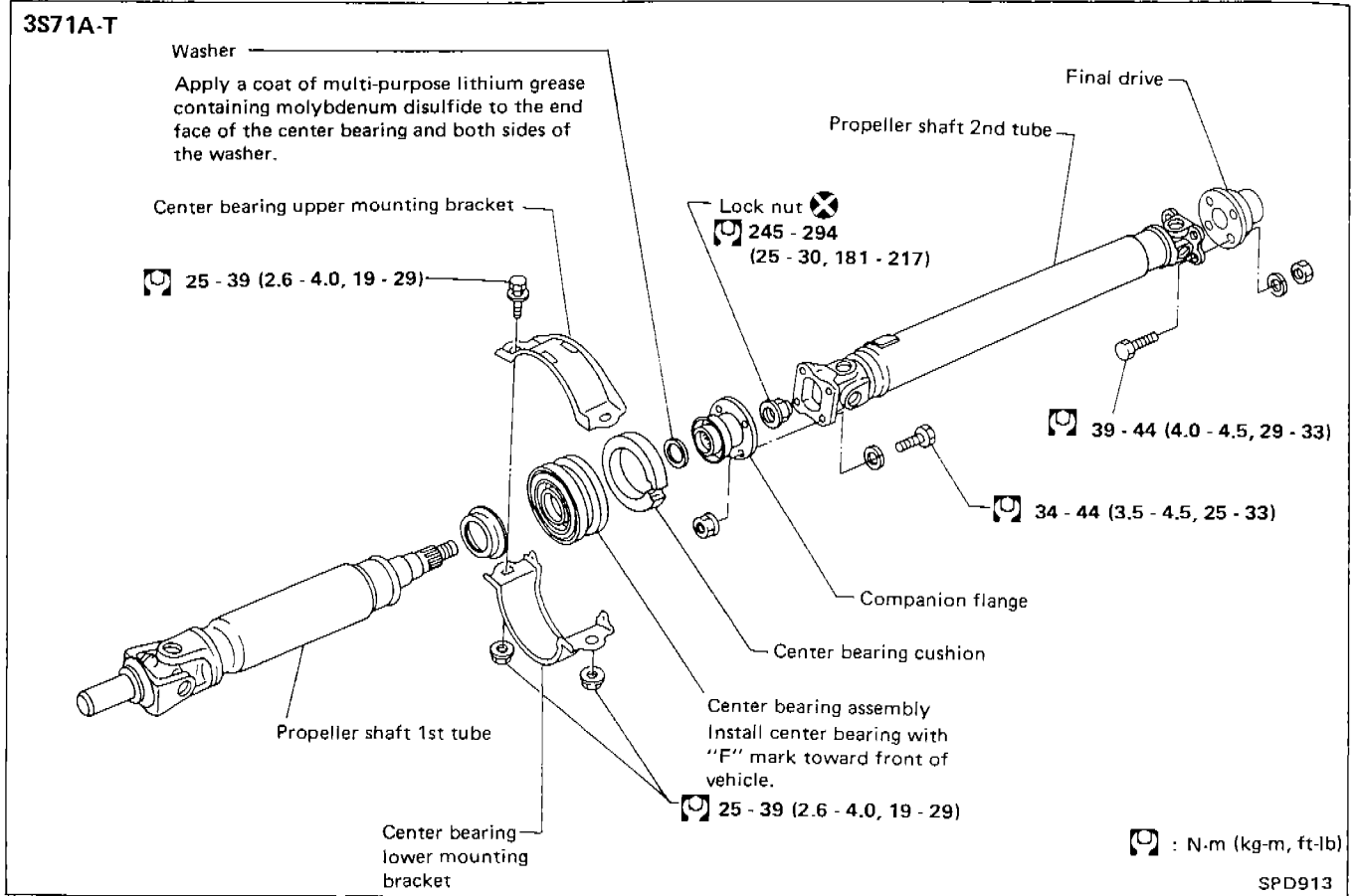

On-vehicle Service

PROPELLER SHAFT VIBRATION

If vibration is present at high speed, inspect propeller shaft runout first.

1. Raise rear wheels.
2. Measure propeller shaft runout at indicated points by rotating final drive companion flange with hands.

Runout limit: 0.6 mm (0.024 in)

Propeller shaft runout measuring points:

Distance "A"
162 mm (6.38 in)

Distance "B"
172 mm (6.77 in)

Distance "C"
192 mm (7.56 in)

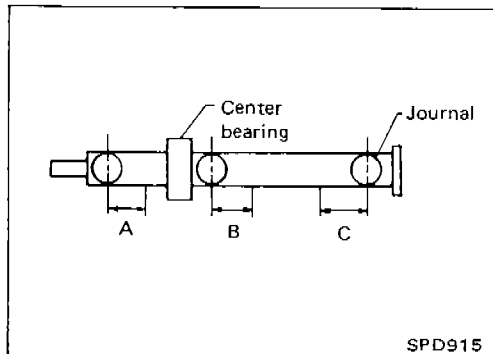

PROPELLER SHAFT

On-vehicle Service (Cont'd)

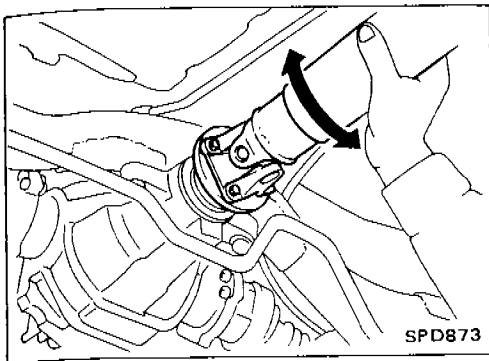

3. If runout exceeds specifications, disconnect propeller shaft at final drive companion flange; then rotate companion flange 180 degrees and reconnect propeller shaft.

Runout limit: 0.6 mm (0.024 in)

4. Check runout again. If runout still exceeds specifications, replace propeller shaft assembly.
5. Perform road test.

APPEARANCE CHECKING

- Inspect propeller shaft tube surface for dents or cracks. If damaged, replace propeller shaft assembly.
- If center bearing is noisy or damaged, replace center bearing.

Removal

- Draw out propeller shaft from transmission and plug up rear end of transmission rear extension housing.

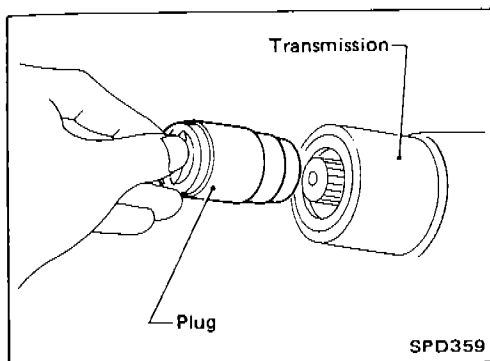

Installation

- Temporarily install differential companion flange and flange yoke so that their alignment marks are located as close to each other as possible.
- Turn propeller shaft until alignment marks face straight upward. Securely fasten propeller shaft so that lower side wall of concave flange yoke will touch lower side wall of convex companion flange.

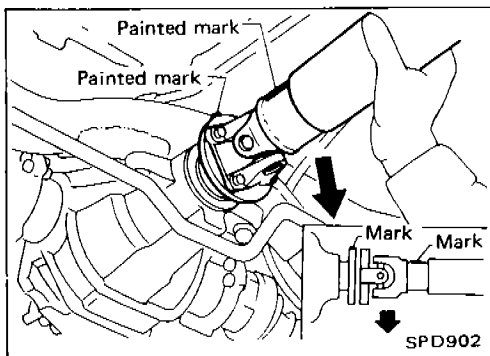

Inspection

- Inspect propeller shaft runout. If runout exceeds specifications, replace propeller shaft assembly.

Runout limit: 0.6 mm (0.024 in)

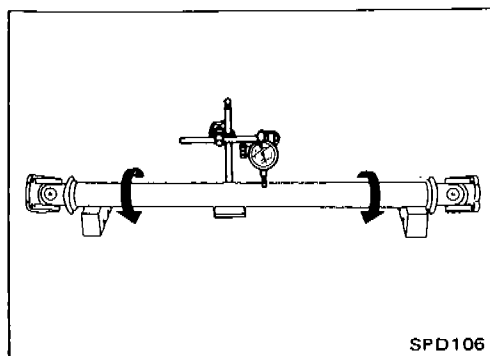

PROPELLER SHAFT

Inspection (Cont'd)

- Inspect journal axial play.
If the play exceeds specifications, replace propeller shaft assembly.

Journal axial play:
0 mm (0 in)

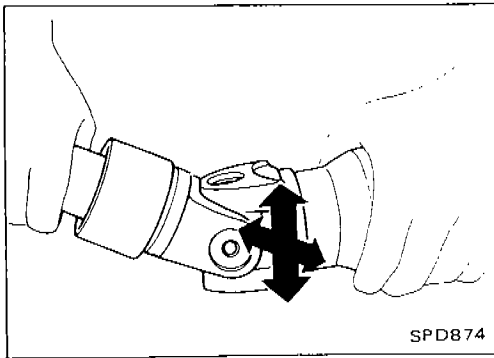

Disassembly

CENTER BEARING

1. Put matchmarks on flanges, and separate 2nd tube from 1st tube.

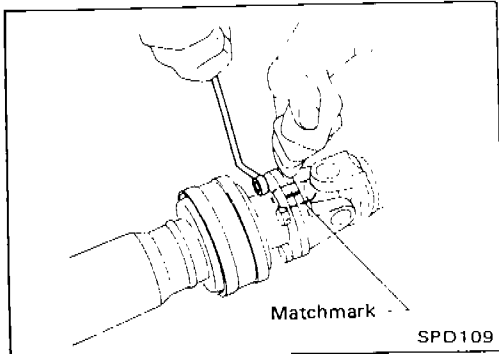

2. Put matchmarks on the flange and shaft.

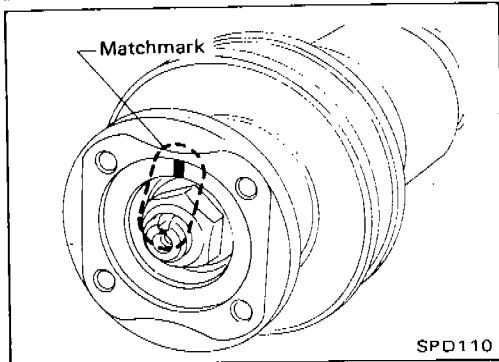

3. Remove locking nut with Tool.

Tool number:
ST38060002

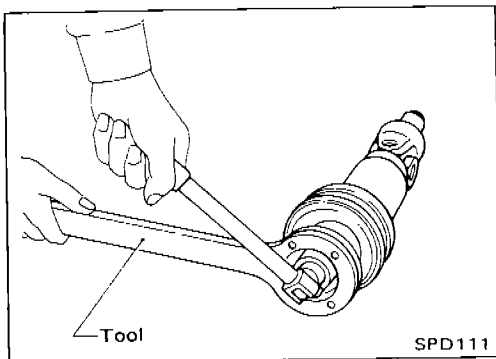

4. Remove companion flange with puller.

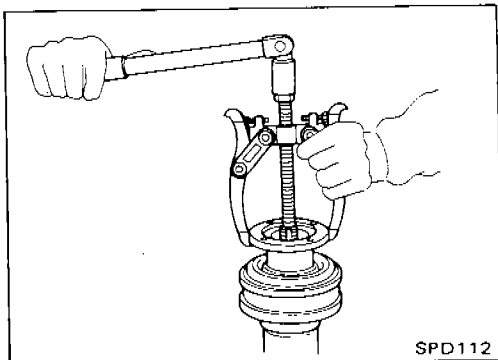

PROPELLER SHAFT

Disassembly (Cont'd)

5. Remove center bearing with Tool and press.
Tool number: ST30031000

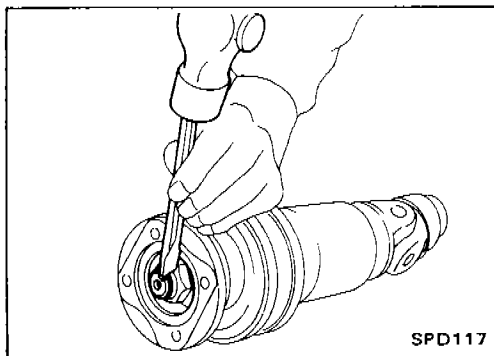
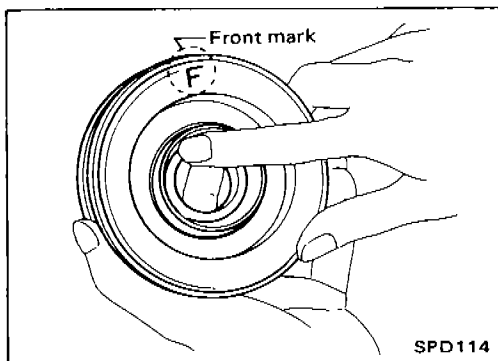
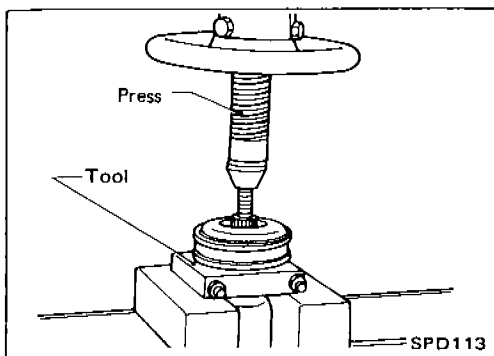

Assembly

CENTER BEARING

- When installing center bearing, position the "F" mark on center bearing toward front of vehicle.
 - Apply a coat of multi-purpose lithium grease containing molybdenum disulfide to the end face of the center bearing and both sides of the washer.
-
- Stake the nut. Always use new one.
 - Align matchmarks when assembling tubes.

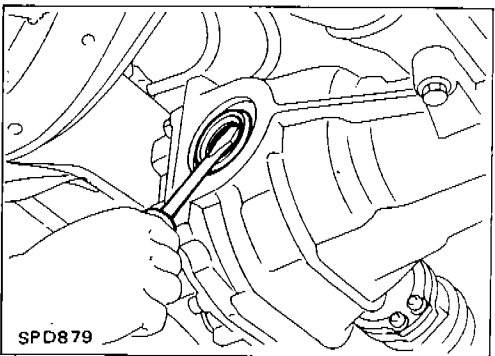
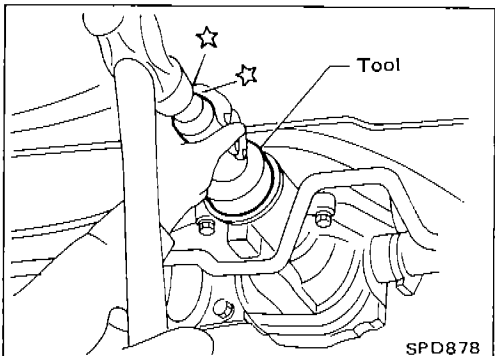
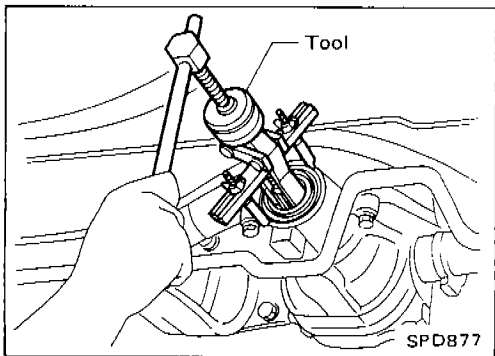
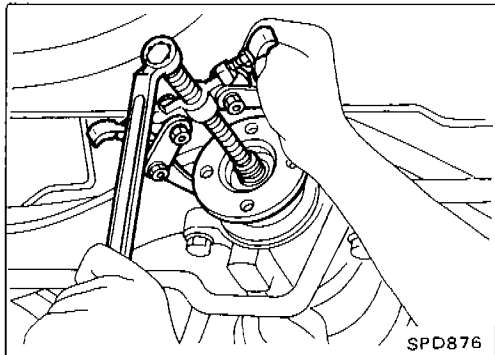
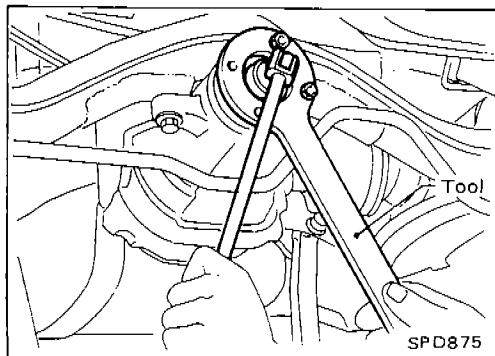

Front Oil Seal Replacement

1. Remove propeller shaft.
2. Loosen drive pinion nut with Tool.
Tool number: ST38060002

3. Remove companion flange.

4. Remove front oil seal.

5. Apply multi-purpose grease to sealing lips of oil seal. Press front oil seal into carrier.
6. Install companion flange and drive pinion nut.
7. Install propeller shaft.

Side Oil Seal Replacement

1. Remove drive shafts.
Refer to RA section.
2. Remove oil seal.

Side Oil Seal Replacement (Cont'd)

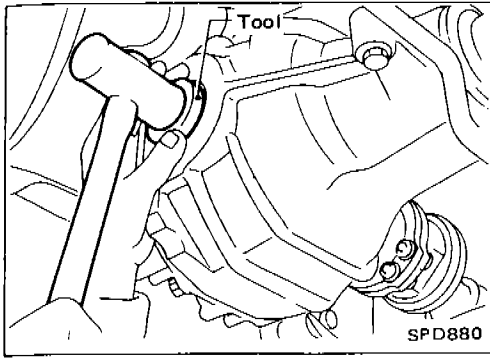

3. Apply multi-purpose grease to sealing lips of oil seal. Press-fit oil seal into carrier with Tool.
Tool number: KV38100200
4. Install drive shafts.

REMOVAL AND INSTALLATION

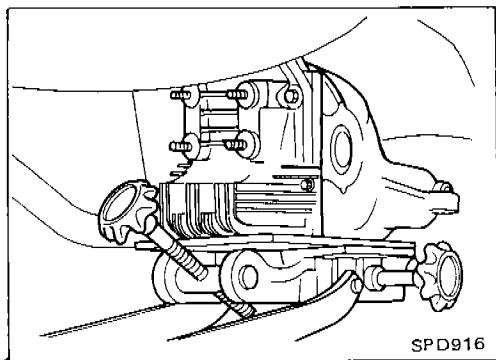

Removal

- Remove propeller shaft.
- Insert plug into rear oil seal after removing propeller shaft.**

- Remove drive shafts.
Refer to RA section.
- Pull off final drive backward together with jack.

CAUTION:

- Be careful not to damage spline, sleeve yoke and front oil seal, when removing propeller shaft.
- After final drive is removed, support suspension member on a stand to prevent its insulators from being twisted or damaged.

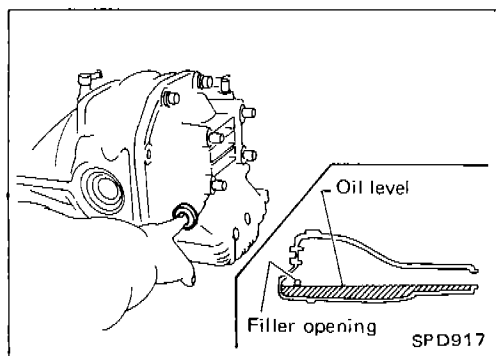

Installation

- Fill final drive with recommended gear oil.

FINAL DRIVE

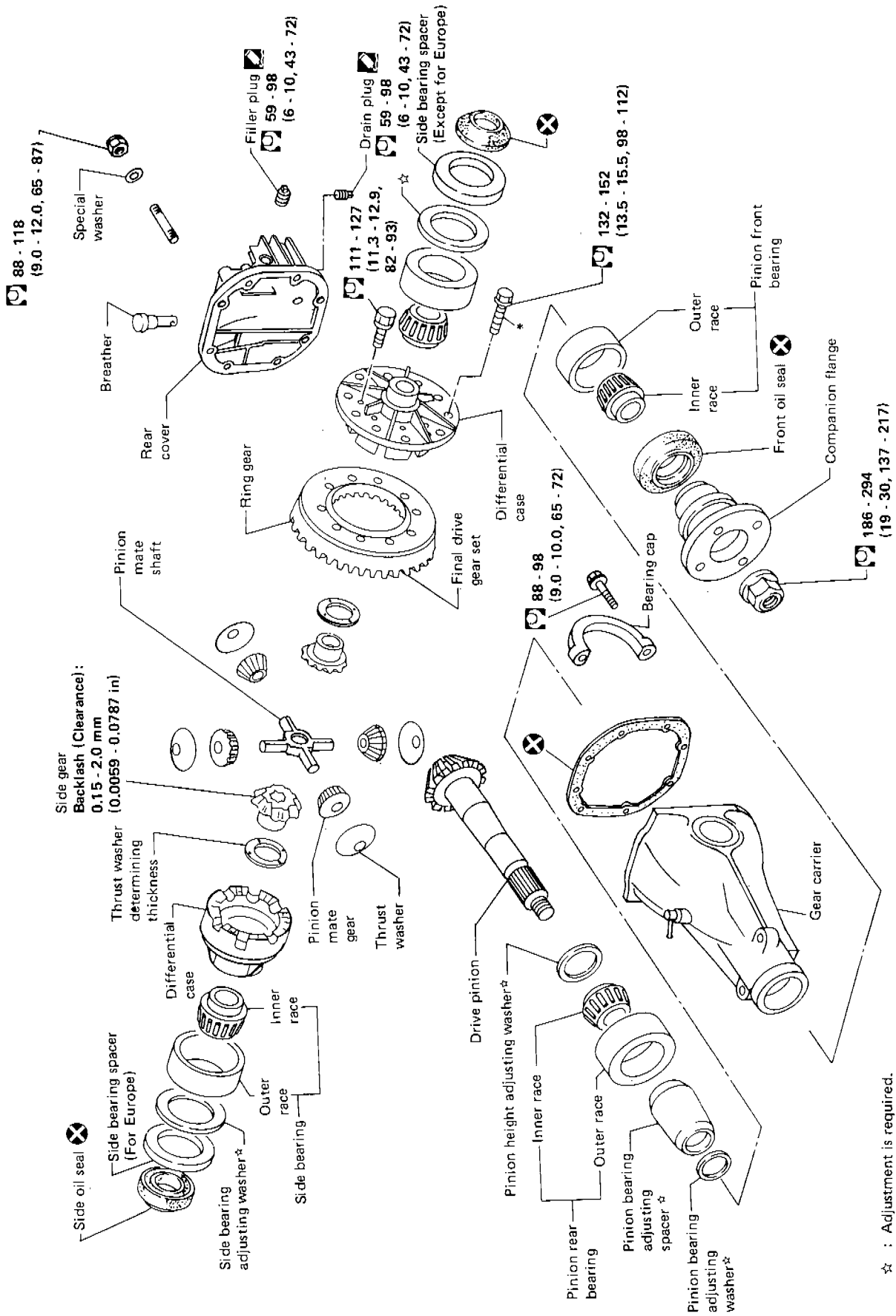

- ☆ : Adjustment is required.
- * : Using locking agent [Loctite (stud lock) or equivalent]
- ☒ : N-m (kg-m, ft-lb)

DISASSEMBLY

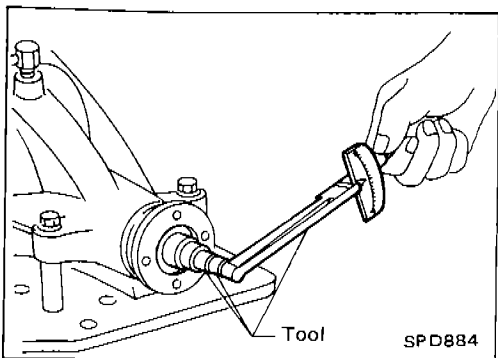

Pre-inspection

Before disassembling final drive, perform the following inspection.

- Total preload
 - 1) Turn drive pinion in both directions several times to set bearing rollers.
 - 2) Check total preload with Tool.

Tool number: ST3127S000

Total preload:

1.4 - 1.7 N·m

(14 - 17 kg-cm, 12 - 15 in-lb)

- Ring gear to drive pinion backlash
Check ring gear-to-drive pinion backlash with a dial indicator at several points.

Ring gear-to-drive pinion backlash:

0.10 - 0.15 mm (0.0039 - 0.0059 in)

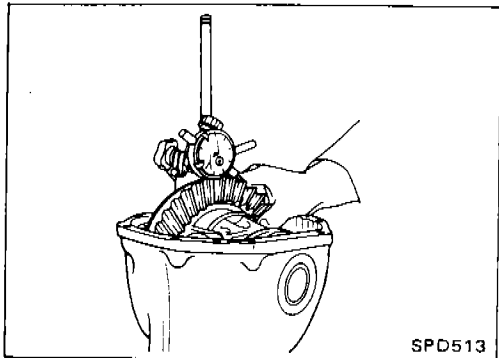

- Ring gear runout
Check runout of ring gear with a dial indicator.

Runout limit:

0.05 mm (0.0020 in)

- Tooth contact
Check tooth contact. (Refer to Adjustment.)

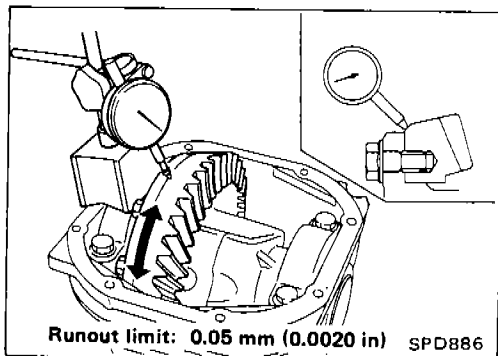

Runout limit: 0.05 mm (0.0020 in) SPD886

Differential Carrier

1. Using two 45 mm (1.77 in) spacers, mount carrier on Tool.

Tool number: KV38100800

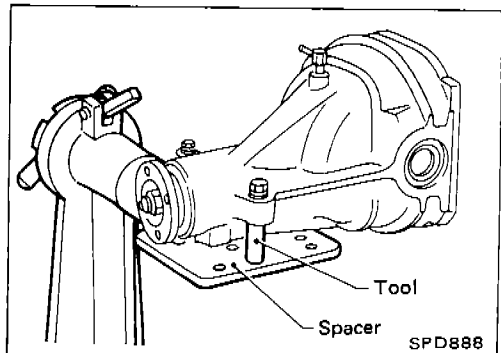

2. Paint or punch matchmarks on one side of the side bearing cap so it can be properly reinstalled.

Bearing caps are line-board during manufacture. Replace them in their proper positions.

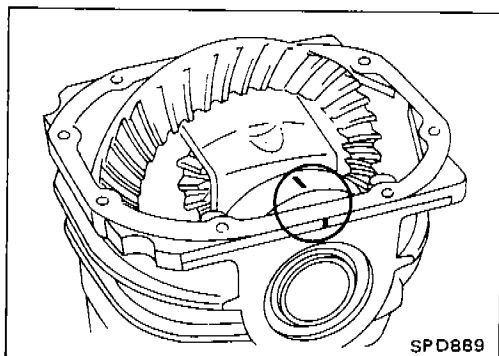

DISASSEMBLY

Differential Carrier (Cont'd)

3. Remove side bearing caps.

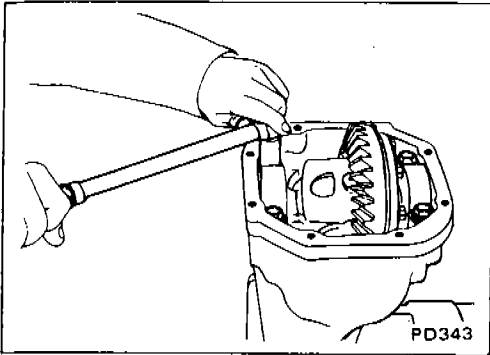

4. Lift differential case assembly out with Tool.
Tool number: HT72400000

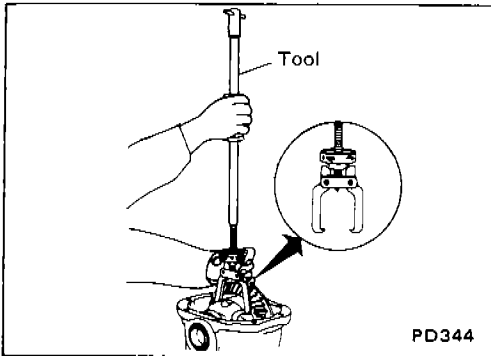

Keep the side bearing outer races together with inner cone — do not mix them up.

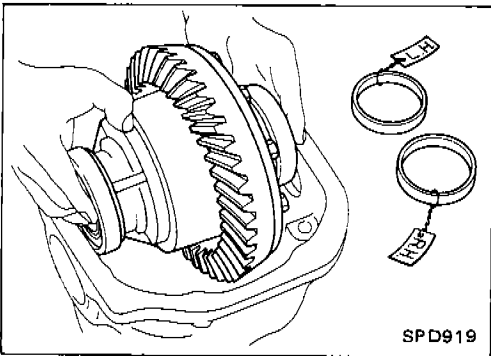

5. Loosen drive pinion nut and pull off companion flange.

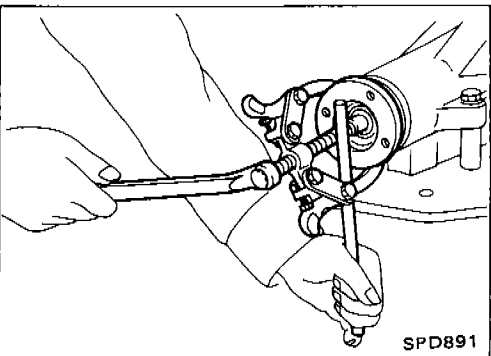
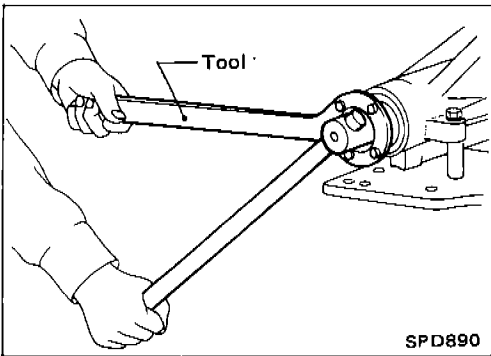

DISASSEMBLY

Differential Carrier (Cont'd)

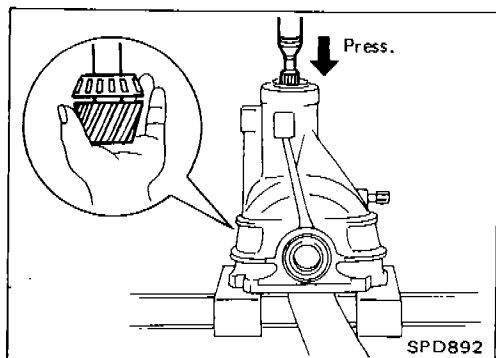

6. Take out drive pinion (together with rear bearing inner race, bearing spacer and adjusting washer).
7. Remove oil seal.
8. Remove front bearing inner race.
9. Remove side oil seal.

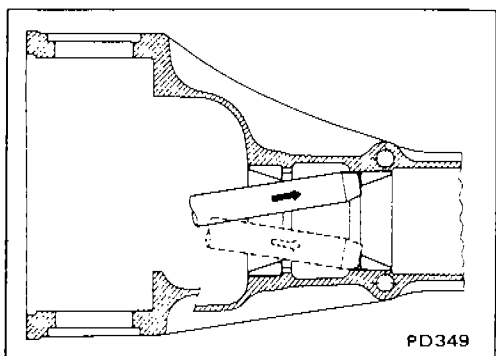

10. Remove pinion bearing outer races with a brass drift.

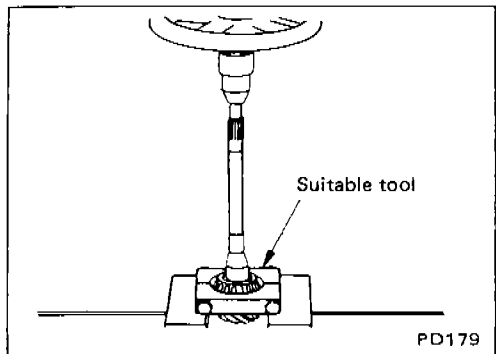

11. Remove pinion rear bearing inner race and drive pinion height adjusting washer with suitable tool.

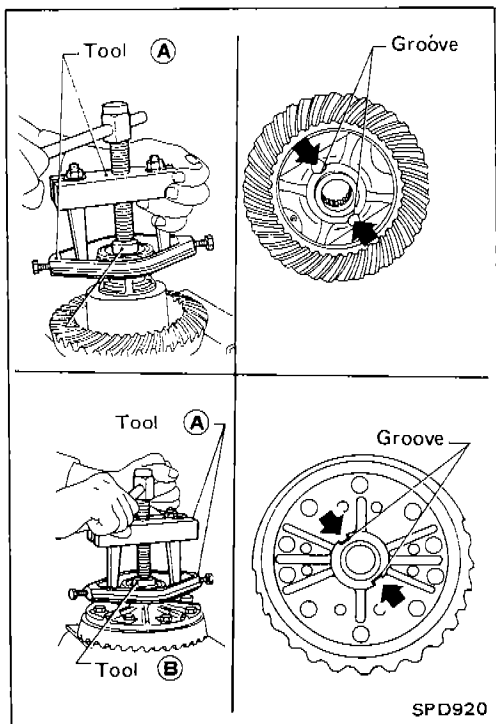

Differential Case

1. Remove side bearing inner cones.
To prevent damage to bearing, engage puller jaws in groove.

Tool number:

- (A) ST33051001
- (B) ST33061000

DISASSEMBLY

Differential Case (Cont'd)

Be careful not to confuse left- and right-hand parts.

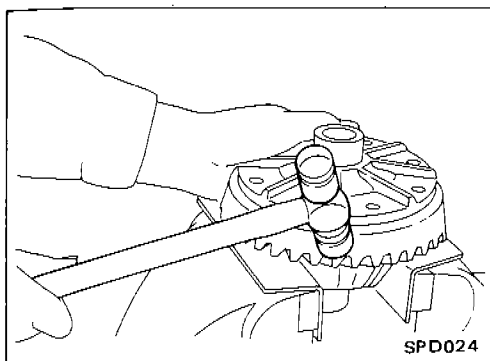
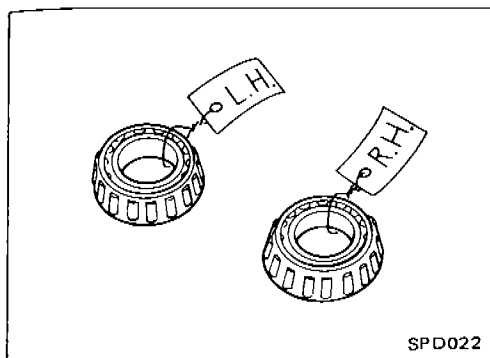

2. Loosen ring gear bolts in a criss-cross fashion.
3. Tap ring gear off the differential case with a soft hammer.
Tap evenly all around to keep ring gear from binding.

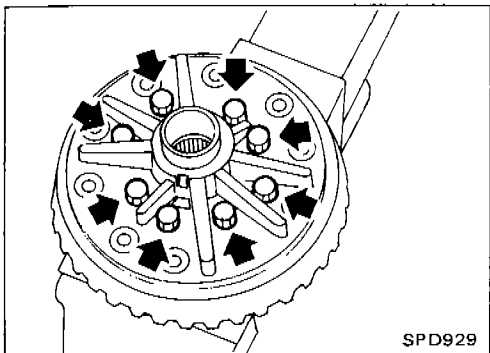

4. Separate differential case L.H. and R.H. (4-pinion type differential case).
Put matchmarks on both differential case L.H. and R.H. sides prior to separating them.

INSPECTION

Ring Gear and Drive Pinion

Check gear teeth for scoring, cracking or chipping. If any part is damaged, replace ring gear and drive pinion as a set (hypoid gear set).

Differential Case Assembly

Check mating surfaces of differential case, side gears, pinion mate gears, pinion mate shaft and thrust washers.

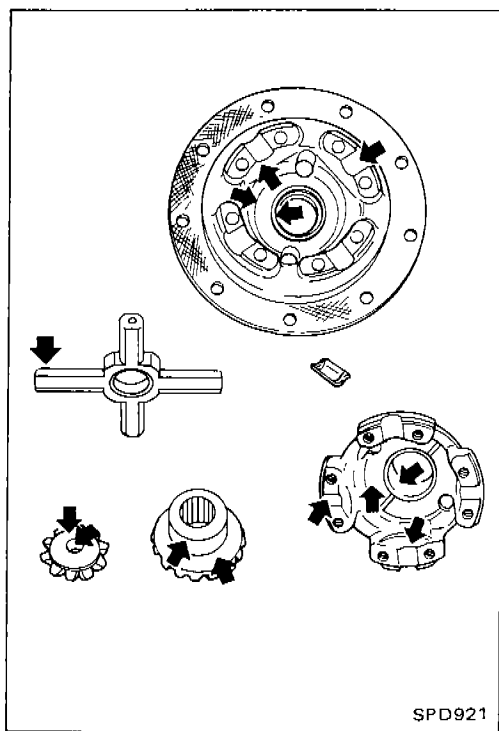

Bearing

1. Thoroughly clean bearing.
2. Check bearings for wear, scratches, pitting or flaking. Check tapered roller bearing for smooth rotation. If damaged, replace outer race and inner cone as a set.

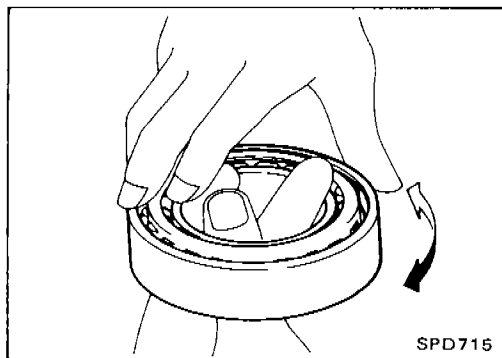

ADJUSTMENT

To avoid confusion while calculating bearing shims, it is absolutely necessary to stay with the metric system. If you measure anything in inches, **the results must be converted to the metric system.**

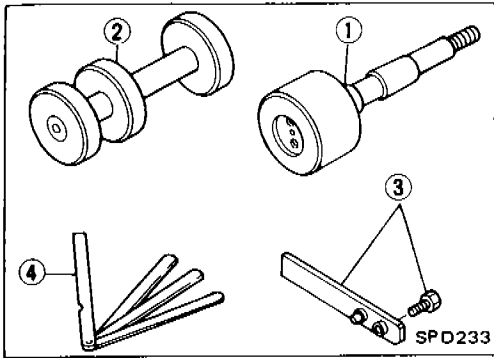

Drive Pinion Height

1. First prepare Tools for pinion height adjustment.

- ① Dummy Shaft (KV38103910)
- ② Height Gauge (KV38100120)
- ③ Stopper (KV38100140)
- ④ Feeler Gauge

2. To simplify the job, make a chart, like the one below, to organize your calculations.

| LETTERS | HUNDREDTHS OF A MILLIMETER |
|-------------------------|-------------------------------|
| H: Head number | |
| N: Measureing clearance | |

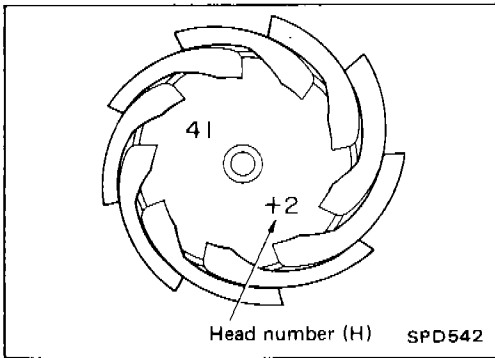

3. Write the following numbers down the chart.

H: Head number

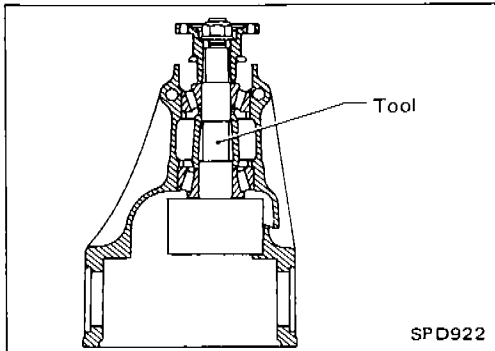

4. Set Tool (Dummy shaft) as shown below and tighten drive pinion nut carefully to corret preload of 1.0 to 1.3 N·m (10 to 13 kg-cm, 8.7 to 11.3 in-lb).

Tool: Dummy shaft (KV38103910)

ADJUSTMENT

Drive Pinion Height (Cont'd)

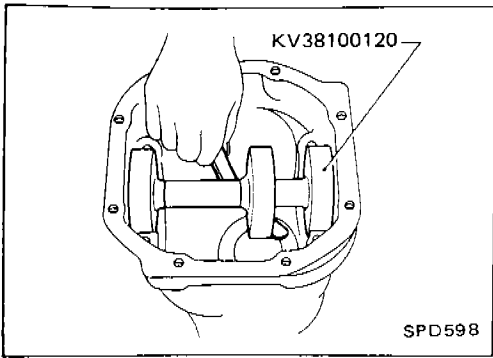

5. Attach Tool (Height gauge) to gear carrier, and measure the clearance between the height gauge and the dummy shaft face.
6. Substitute these values into the equation to calculate the thickness of the washer.

If value signifying H is not given, regard it as zero and calculate.

$$T \text{ (Thickness of washer)} = N - (H \times 0.01) + 3.00$$

Example:

$$N = 0.23$$

$$H = 1$$

$$T = N - (H \times 0.01) + 3.00$$

$$= 0.23 - (1 \times 0.01) + 3.00$$

| | | | |
|-----|---------|------|------------|
| (1) | H | 1 | |
| | | | +1 |
| (2) | | | +1 |
| | | | x 0.01 |
| | | | +0.01 |
| (3) | N | 0.23 | |
| | | | - (+0.01) |
| | | | 0.22 |
| (4) | | | 0.22 |
| | | | +3.00 |
| | | | 3.22 |
| | | | ∴ T = 3.22 |

7. Select the proper washer. (Refer to S.D.S.)

If you cannot find the desired thickness of washer, use washer with thickness closest to the calculated value.

Example:

Calculated value ... $T = 3.22 \text{ mm}$

Used washer ... $T = 3.21 \text{ mm}$

ADJUSTMENT

Side Bearing Preload

- To simplify the job, make a chart like the one below to organize your calculations.

| LETTERS | HUNDREDTHS OF A MILLIMETER |
|---------------------------|----------------------------|
| A - Left housing | |
| B - Right housing | |
| C - Differential case | |
| D - Differential case | |
| E - Left side bearing | |
| F - Right side bearing | |
| H - (+) or (-): ring gear | |
| G - Spacer measurement | |

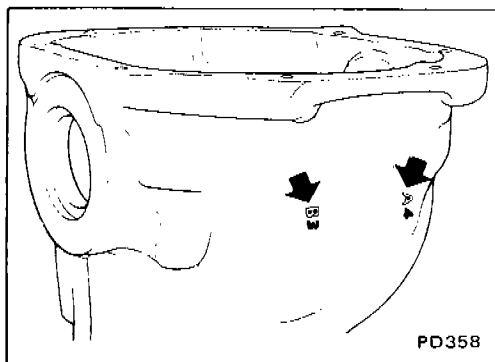

- Write the following numbers down in the chart.
A & B: Figures marked on gear carrier

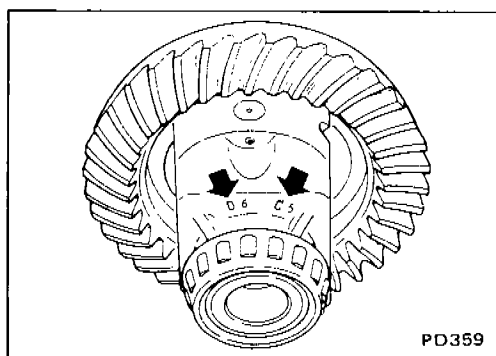

C & D: Figures marked on differential case

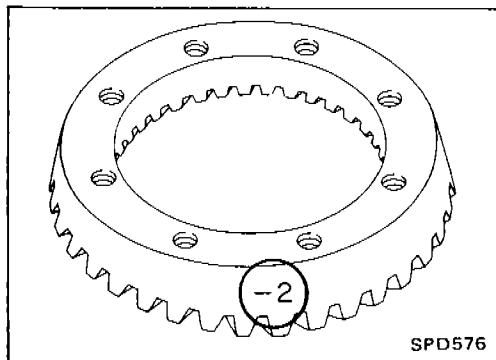

H: Figure marked on ring gear

ADJUSTMENT

Side Bearing Preload (Cont'd)

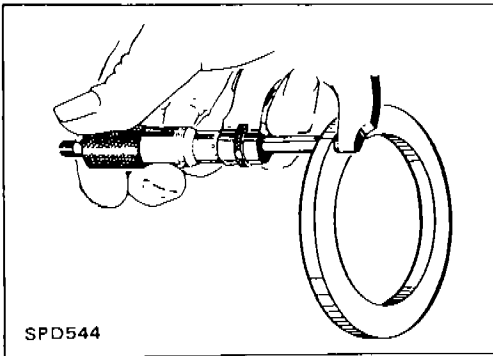

G: This is the difference in thickness of side spacer against standard width [8.10 mm (0.3189 in)].
(G = Standard spacer - Measured spacer)

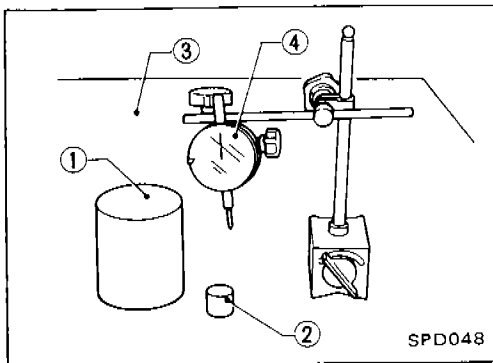

3. Measure how far under the standard thickness [21 mm (0.83 in)] the side bearings are.
It will require tools shown to the left.

- ① Weight Block (ST32501000)
- ② Master Gauge (KV38102000)
- ③ Base Plate
- ④ Dial Indicator

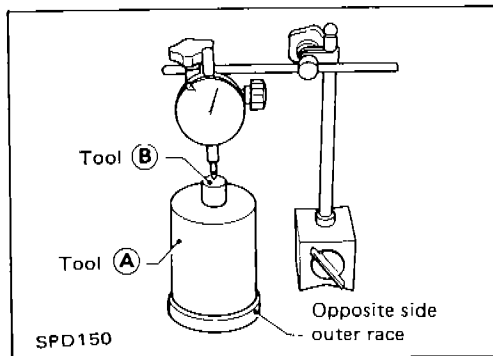

4. Place the outer race of the opposite side bearing to be measured.
5. Place a weight block on that outer race, and a master gauge on that block.

Tool number:

- Ⓐ ST32501000
- Ⓑ KV38102000

6. Adjust dial indicator scale to zero.
7. Carefully slide master gauge block and weight block out from under dial indicator.

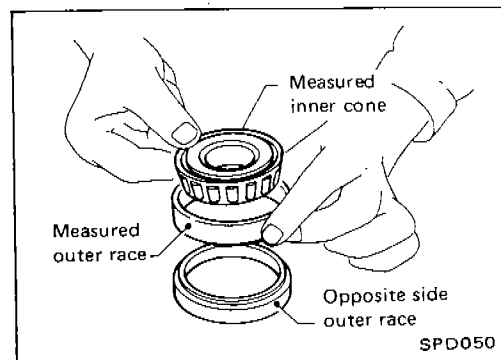

8. Lubricate side bearing and place the bearing outer race and inner cone to be measured on the opposite side outer race.
If the bearing assembly is placed on the base plate, the bearing width cannot be accurately determined due to its cage being in contact with the base plate.

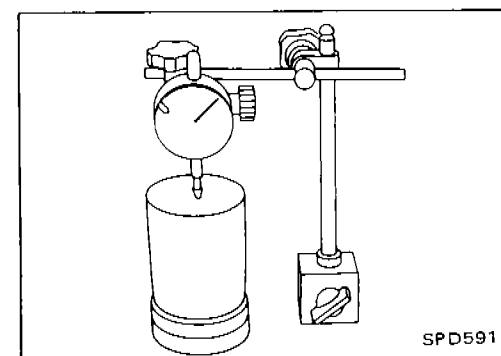

9. Place weight block on side bearing.
10. Slide dial indicator on weight block.

ADJUSTMENT

Side Bearing Preload (Cont'd)

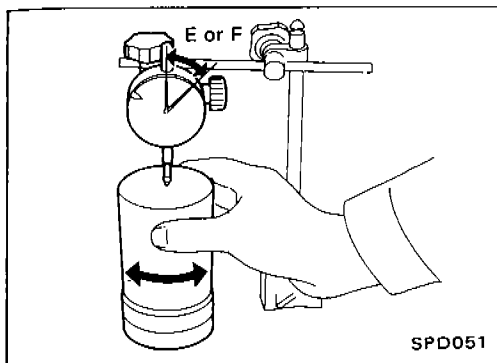

11. Turn weight block a few times to ensure that bearing is properly seated.
12. Read dial indicator.
 - Normal indication:
0.10 - 0.30 mm (0.0039 - 0.0018 in)
 - If the needle fluctuated erratically then bearing is either dirty or damaged and should be cleaned or replaced.
13. Measure both bearings in the same way and write the left side bearing measurement next to "E" and the right side bearing measurement next to "F".
14. Substitute these values into the equation to calculate the thickness of the shim.

If values signifying A, B, C, D and H are not given, regard them as zero and calculate.

Europe model:

Left side

$$T_1 = (A - C + D - H) \times 0.01 + 2.07 + E$$

Right side

$$T_2 = (B - D + H) \times 0.01 + 1.97 + F + G$$

Except Europe model:

Left side

$$T_2 = (B - D + H) \times 0.01 + 1.97 + F + G$$

Right side

$$T_1 = (A - C + D - H) \times 0.01 + 2.07 + E$$

ADJUSTMENT

Side Bearing Preload (Cont'd)

Example:

| | |
|-------|----------|
| A = 4 | H = -2 |
| B = 3 | E = 0.18 |
| C = 5 | F = 0.15 |
| D = 6 | G = 0.08 |

Left side: Europe

Right side: Except Europe

$$T_1 = (A - C + D - H) \times 0.01 + 2.07 + E$$

$$= [4 - 5 + 6 - (-2)] \times 0.01 + 2.07 + 0.18$$

| | | | |
|-----|----------|--------|--|
| (1) | A | 4 | |
| | -C | -5 | |
| | | -1 | |
| | +D | +6 | |
| | | 5 | |
| | -H | -(-2) | |
| | | 7 | |
| (2) | | 7 | |
| | | x 0.01 | |
| | | 0.07 | |
| (3) | | 0.07 | |
| | | +2.07 | |
| | | 2.14 | |
| (4) | | 2.14 | |
| | +E | +0.18 | |
| | | 2.32 | |

$$\therefore T_1 = 2.32 \text{ mm}$$

Right side: Europe

Left side: Except Europe

$$T_2 = (B - D + H) \times 0.01 + 1.97 + F + G$$

$$= [3 - 6 + (-2)] \times 0.01 + 1.97 + 0.15 + 0.08$$

| | | | |
|-----|----------|--------|--|
| (1) | B | 3 | |
| | -D | -6 | |
| | | -3 | |
| | +H | +(-2) | |
| | | -5 | |
| (2) | | -5 | |
| | | x 0.01 | |
| | | -0.05 | |
| (3) | | -0.05 | |
| | | +1.97 | |
| | | 1.92 | |
| (4) | | 1.92 | |
| | +F | +0.15 | |
| | | 2.07 | |
| | | 2.07 | |
| | +G | +0.08 | |
| | | 2.15 | |

$$\therefore T_2 = 2.15 \text{ mm}$$

15. Select the proper shims. (Refer to S.D.S.)

If you cannot find the desired thickness of shims, use shims with the total thickness closest to the calculated value.

ADJUSTMENT

Tooth Contact

Checking gear tooth contact pattern is necessary to verify correct relationship between ring gear and drive pinion. Hypoid gear set which is not positioned properly in relation to one another may be noisy, or have short life or both. With the checking of gear tooth contact pattern, the most desirable contact for low noise level and long life can be assured.

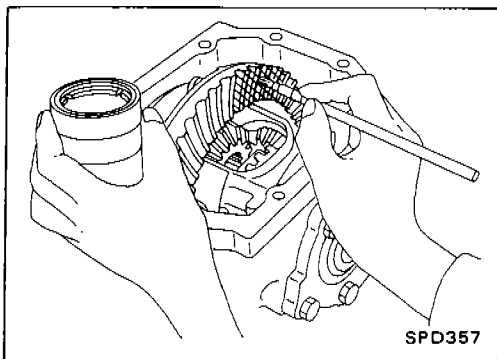

1. Thoroughly clean ring gear and drive pinion teeth.
2. Sparingly apply a mixture of powdered ferric oxide and oil or equivalent to 3 or 4 teeth of ring gear drive side.

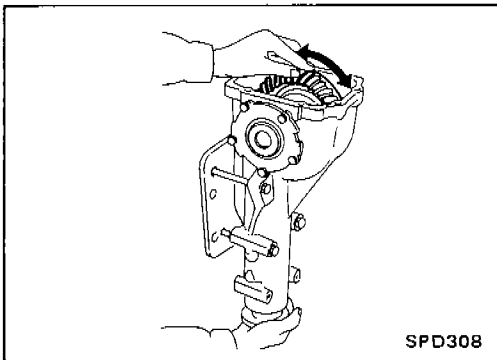

3. Hold companion flange steady by hand and rotate the ring gear in both directions.

Usually the pattern will be correct if you have calculated the shims correctly and the backlash is correct. However, in rare cases you may have to use trial-and-error processes until you get a good tooth contact pattern. The tooth pattern is the best indication of how well the final drive has been set up.

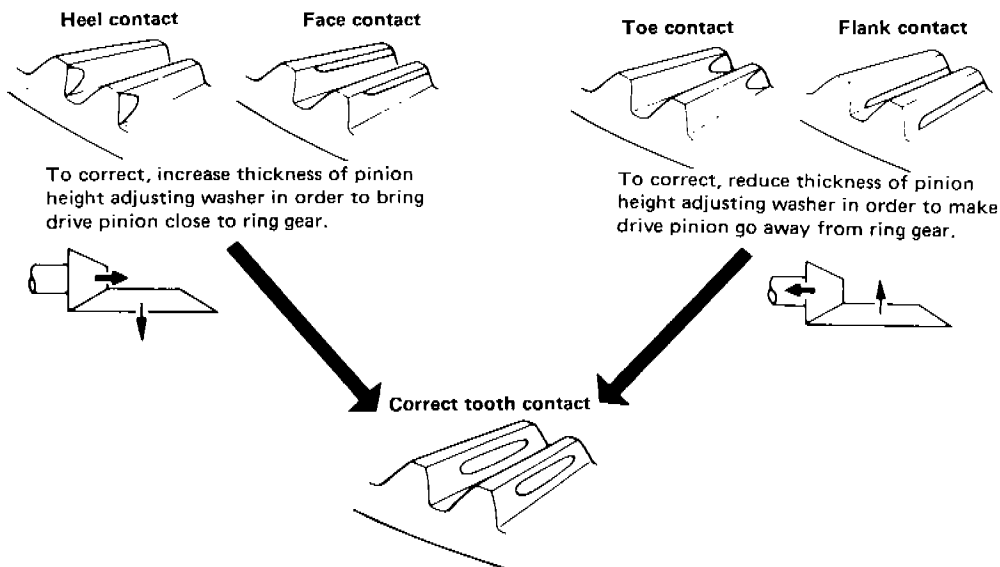

SPD007

ASSEMBLY

Differential Case

1. Measure clearance between side gear thrust washer and differential case.

Clearance between side gear thrust washer and differential case (A - B):

0.15 - 0.20 mm (0.0059 - 0.0079 in)

The clearance can be adjusted with side gear thrust washer. Refer to S.D.S.

2. Apply oil to gear tooth surfaces and thrust surfaces and check that they turn properly.

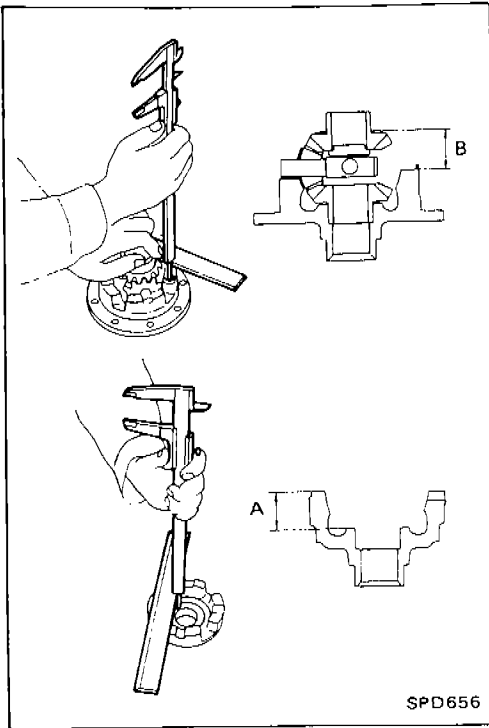

3. Install differential case L.H. and R.H.

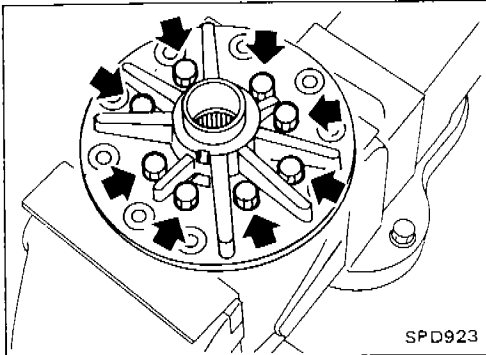

4. Place differential case on ring gear.
5. Apply locking sealant to ring gear bolts, and install them. **Tighten bolts in a criss-cross fashion, lightly tapping bolt head with a hammer.**

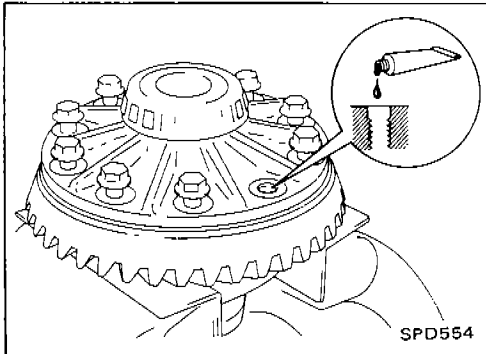

6. Press-fit side bearing inner cones on differential case with Tool.

Tool number:

(A) KV38100300

(B) ST33061000

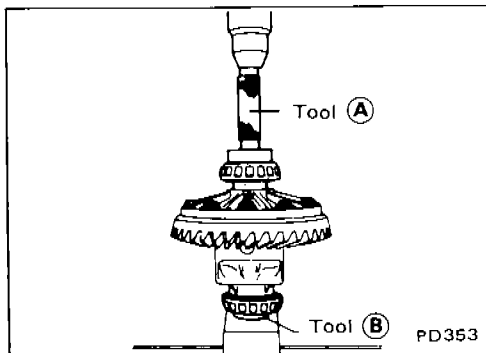

ASSEMBLY

Differential Carrier

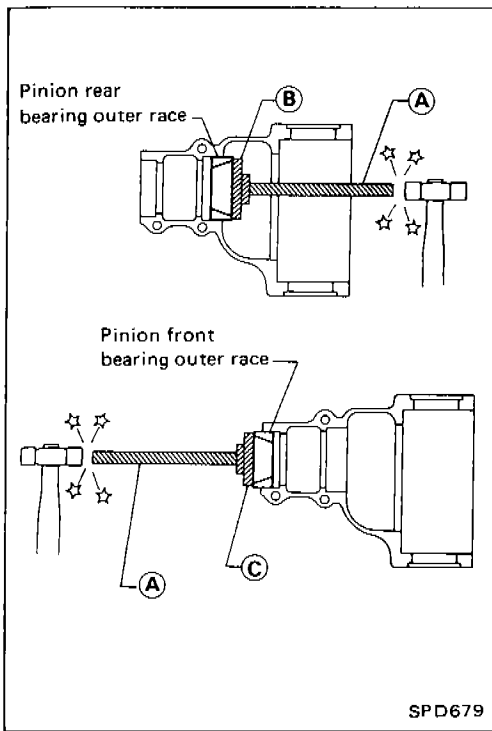

1. Press-fit front and rear bearing outer races with Tools.

Tool number:

(A) ST30611000

(B) ST30613000

(C) ST30701000

2. Select pinion bearing adjusting washer and drive pinion bearing spacer, referring to ADJUSTMENT.

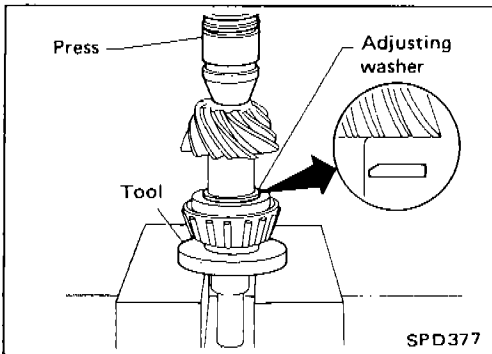

3. Install drive pinion height adjusting washer in drive pinion, and press-fit pinion rear bearing inner cone in it, using press and Tool.

Tool number: ST30901000

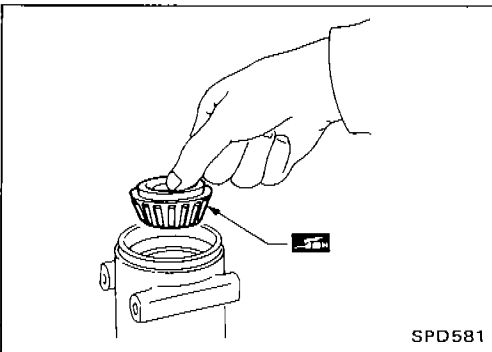

4. Place pinion front bearing inner cone in final drive housing.

ASSEMBLY

Differential Carrier (Cont'd)

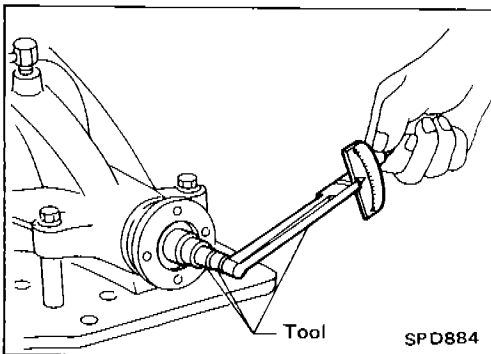
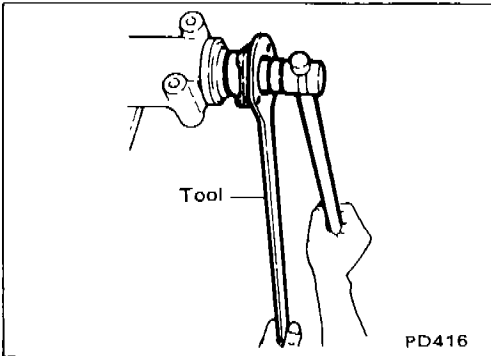
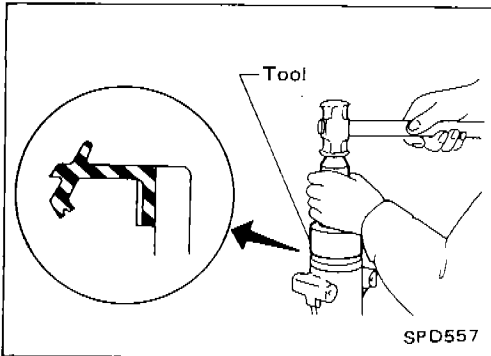
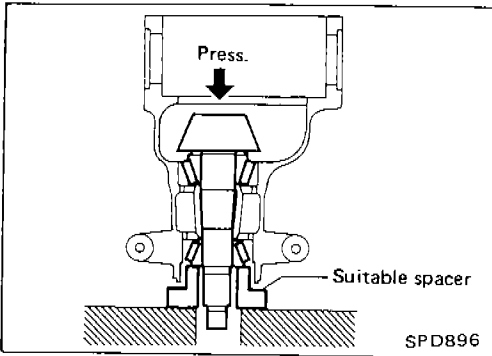
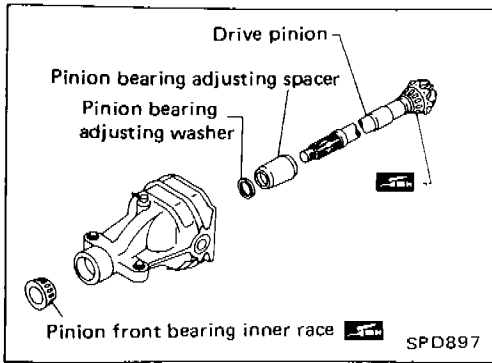

5. Set drive pinion assembly (as shown in figure at left) in differential carrier and install drive pinion, with press and suitable tool.

Stop when drive pinion touches bearing.

Apply multi-purpose grease to pinion rear bearing inner race, pinion front bearing inner race and front pilot bearing.

6. Apply multi-purpose grease to cavity at sealing lips of oil seal. Install front oil seal with Tool.

Tool number: KV38100500

7. Install companion flange, and tighten pinion nut to specified torque with Tool.

Ascertain that threaded portion of drive pinion and pinion nut are free from oil or grease.

Tool number: ST38060002

8. Turn drive pinion in both directions several times, and measure pinion bearing preload.

Pinion bearing preload:

1.1 - 1.4 N·m

(11 - 14 kg-cm, 9.5 - 12.2 in-lb)

When pinion bearing preload is outside the specifications, replace pinion bearing adjusting washer and spacer with a different thickness.

ASSEMBLY

Differential Carrier (Cont'd)

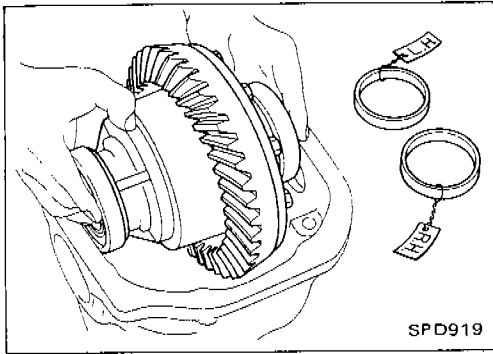

9. Select side bearing adjusting washer.
Refer to ADJUSTMENT.
10. Install differential case assembly with side bearing outer races into gear carrier.

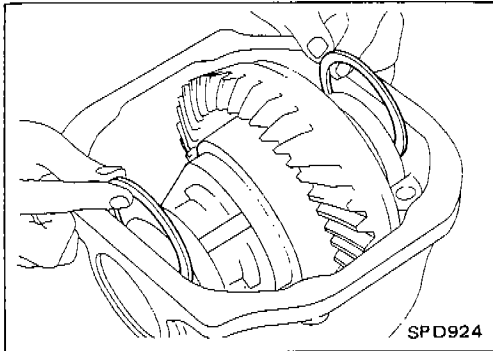

11. Insert left and right side bearing adjusting washers in place between side bearings and carrier.

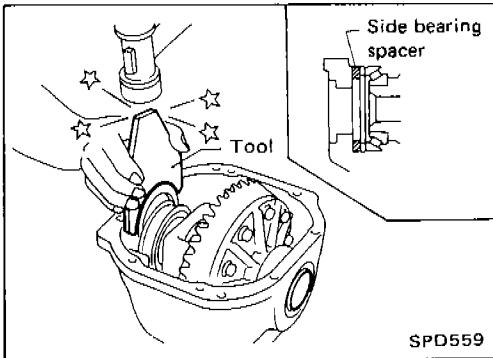

12. Drive in side bearing spacer with Tool.
Tool number: KV38100600

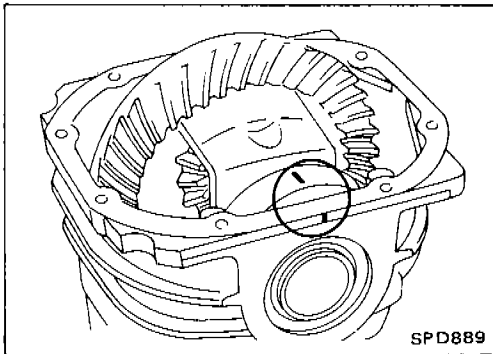

13. Align mark on bearing cap with that on gear carrier and install bearing cap on gear carrier.

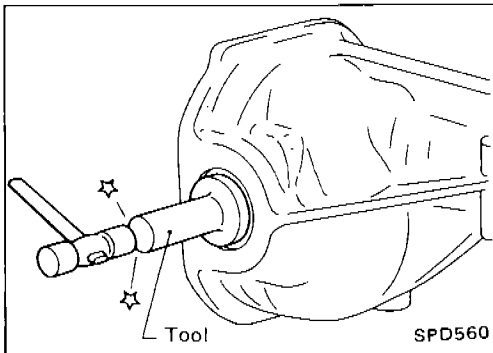

14. Apply multi-purpose grease to cavity at sealing lips of oil seal. Install side oil seal.
Tool number: KV38100200

ASSEMBLY

Differential Carrier (Cont'd)

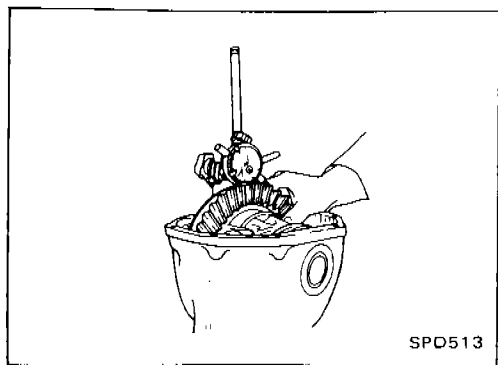

15. Measure ring gear-to-drive pinion backlash with a dial indicator.

Ring gear-to-drive pinion backlash:

0.10 - 0.15 mm

(0.0039 - 0.0059 in)

- If backlash is too small, decrease thickness of left shim and increase thickness of right shim by the same amount.

If backlash is too great, reverse the above procedure.

Never change the total amount of shims as it will change the bearing preload.

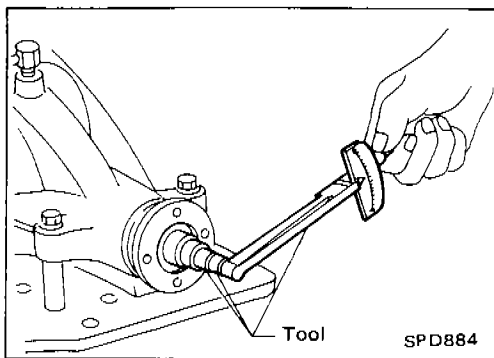

16. Check total preload with Tool.

When checking preload, turn drive pinion in both directions several times to seat bearing rollers correctly.

Total preload:

Value more than 0.29 N·m (3.0 kg-cm, 2.6 in-lb) added on measured value of drive pinion preload

- If preload is too great, remove the same amount of shim to each side.
- If preload is too small, add the same amount of shim to each side.

Never add or remove a different number of shims for each side as it will change ring gear-to-drive pinion backlash.

17. Recheck ring gear-to-drive pinion backlash because increase or decrease in thickness of shims will cause change of ring gear-to-pinion backlash.

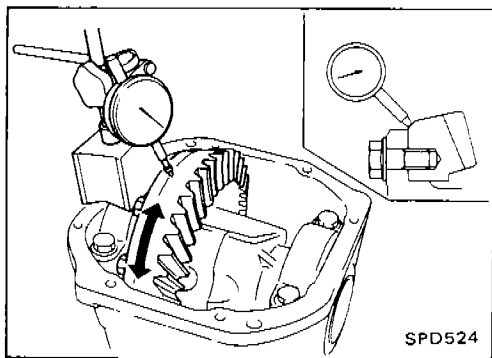

18. Check runout of ring gear with a dial indicator.

Runout limit:

0.05 mm (0.0020 in)

- If backlash varies excessively in different places, foreign matter may be caught between the ring gear and the differential case.
- If the backlash varies greatly when the ring gear runout is within a specified range, replace the hypoid gear set or differential case.

19. Check tooth contact.

Refer to ADJUSTMENT.

20. Install rear cover and gasket.

DIFFERENTIAL GEAR OIL COOLER SYSTEM

Description

- In this system, when the differential gear oil temperature exceeds the specified value, the temperature switch which is installed in the rear cover senses the temperature of the gear oil and activates the magnetic pump. The magnetic pump circulates differential gear oil which is cooled by the cooler located in the rear of the vehicle.
- The pump automatically repeats ON-OFF operation according to the temperature of the differential gear oil.
 - OFF → ON 132 - 138°C (270 - 280°F)
 - ON → OFF 124 - 130°C (255 - 266°F)However, the pump will not operate when the vehicle speed is less than 10 km/h (6 MPH).
- When the oil temperature becomes excessively high, the warning lamp in the combination meter will illuminate.
 - OFF → ON 180°C (356°F)
 - ON → OFF 155°C (311°F)

Removal and Installation

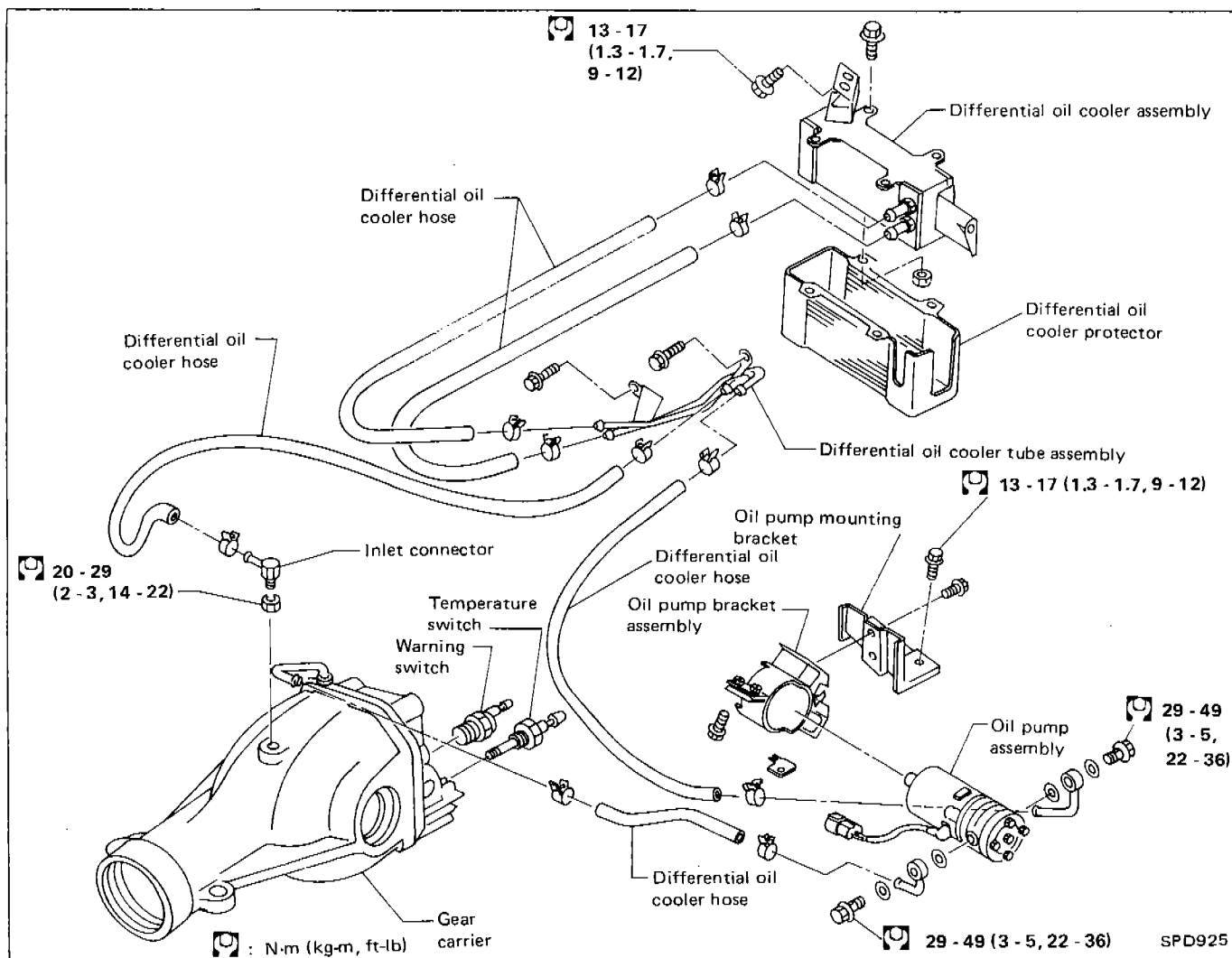

DIFFERENTIAL GEAR OIL COOLER SYSTEM

Wiring Diagram/Differential Oil Cooler System

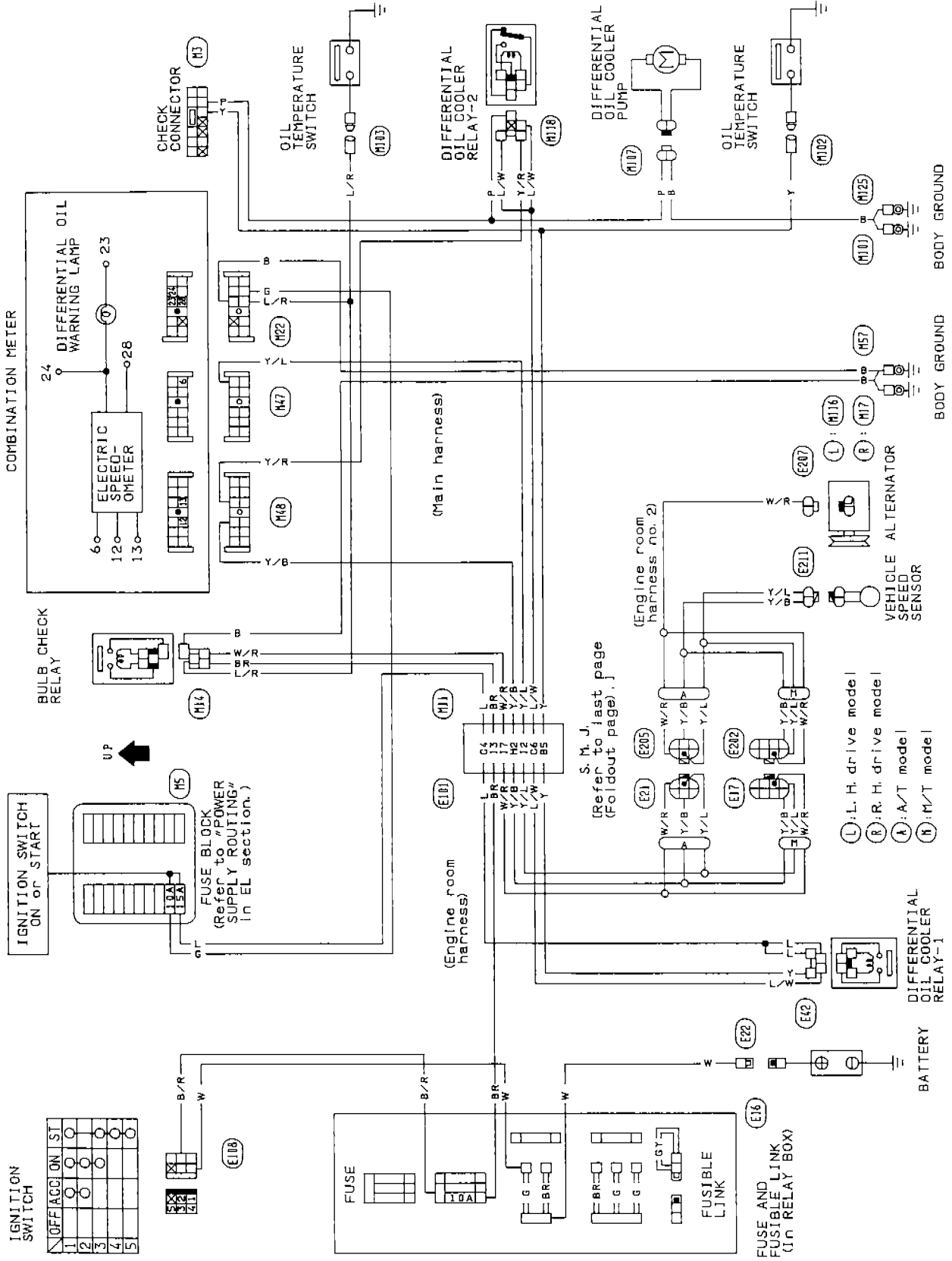

SPD926

DIFFERENTIAL GEAR OIL COOLER SYSTEM

Inspection

Thoroughly clean all parts in cleaning solvent and blow dry with compressed air, if available.

OIL PUMP ASSEMBLY

Replace oil pump assembly when motor does not rotate because of motor seizure or other damage.

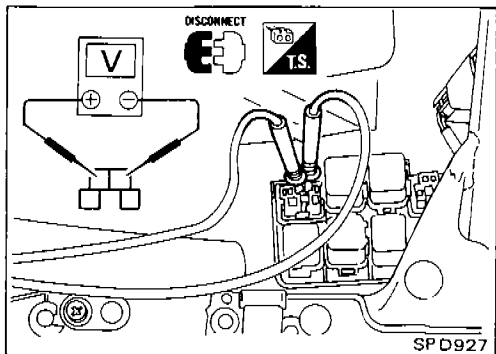

SPEEDOMETER AMPLIFIER

Check speedometer amplifier operation as follows:

1. Disconnect differential oil cooler relay-1 from relay box and connect circuit tester to connector for relay-1 in relay box as shown.
2. Raise rear wheels.
3. Drive vehicle slowly and check the voltage.

Less than 10 km/h (6 MPH) ... Approx. 12V

More than 10 km/h (6 MPH) ... 0V

OIL COOLER ASSEMBLY, OIL TUBE ASSEMBLY, OIL HOSE

If oil leakage is detected during removal, replace oil cooler assembly or oil tube.

SERVICE DATA AND SPECIFICATIONS (S.D.S.)

Propeller Shaft

GENERAL SPECIFICATIONS

Unit: mm (in)

| Transmission type | M/T | | A/T | |
|-----------------------------------|------------------------------------------------------------|------------------|------------------|------------------|
| Anti-skid brake system | Yes | No | Yes | No |
| Propeller shaft model | 3S71A-T | | | |
| Number of joints | 3 | | | |
| Coupling method with transmission | Sleeve type | | | |
| Type of journal bearings | Shell type (Non-disassembly type) | | | |
| Distance between yokes | 75.0 (2.953) | | | |
| Shaft length (Spider to spider) | 410.0 (16.14) | | 430.0 (16.93) | |
| | 1st | 2nd | 1st | 2nd |
| | 585.0 (23.03) | 600.0 (23.62) | 585.0 (23.03) | 600.0 (23.62) |
| Shaft outer diameter | 75.0 (2.953) | | | |
| | 1st | | | |
| | 75.0 (2.953) ... Large side 63.5 (2.500) ... Small side | | | |
| | 2nd | | | |

SPECIFICATIONS AND ADJUSTMENT

Unit: mm (in)

| | |
|------------------------------|-------------|
| Propeller shaft model | 3S71A-T |
| Propeller shaft runout limit | 0.6 (0.024) |
| Journal axial play | 0 (0) |

SERVICE DATA AND SPECIFICATIONS (S.D.S.)

Final Drive

GENERAL SPECIFICATIONS

| Final drive model | R200 | |
|-------------------------------------------------|-------------|---------------|
| | Europe | Except Europe |
| Ring gear pitch diameter mm (in) | 205 (8.07) | |
| Gear ratio | 3.916 | 4.363 |
| Number of teeth (Ring gear/ Drive pinion) | 47/12 | 48/11 |
| Oil capacity (approx.) ℓ (Imp pt) | 1.8 (3-1/8) | |

SPECIFICATIONS AND ADJUSTMENT

Drive pinion adjustment

| | |
|-----------------------------------------------|---------------------------------|
| Drive pinion bearing adjusting method | Pinion bearing adjusting washer |
| Drive pinion to ring gear backlash mm (in) | 0.10 - 0.15 (0.0039 - 0.0059) |

Available pinion height adjusting washer

| Thickness mm (in) | Part number |
|-------------------|-------------|
| 3.09 (0.1217) | 38154-P6017 |
| 3.12 (0.1228) | 38154-P6018 |
| 3.15 (0.1240) | 38154-P6019 |
| 3.18 (0.1252) | 38154-P6020 |
| 3.21 (0.1264) | 38154-P6021 |
| 3.24 (0.1276) | 38154-P6022 |
| 3.27 (0.1287) | 38154-P6023 |
| 3.30 (0.1299) | 38154-P6024 |
| 3.33 (0.1311) | 38154-P6025 |
| 3.36 (0.1323) | 38154-P6026 |
| 3.39 (0.1335) | 38154-P6027 |
| 3.42 (0.1346) | 38154-P6028 |
| 3.45 (0.1358) | 38154-P6029 |
| 3.48 (0.1370) | 38154-P6030 |
| 3.51 (0.1382) | 38154-P6031 |
| 3.54 (0.1394) | 38154-P6032 |
| 3.57 (0.1406) | 38154-P6033 |
| 3.60 (0.1417) | 38154-P6034 |
| 3.63 (0.1429) | 38154-P6035 |
| 3.66 (0.1441) | 38154-P6036 |

Drive pinion preload adjustment

| | |
|-------------------------------------------------------------------|---------------------------------|
| Drive pinion preload N-m (kg-cm, in-lb) With front oil seal | 1.1 - 1.4 (11 - 14, 9.5 - 12.2) |
|-------------------------------------------------------------------|---------------------------------|

Available drive pinion bearing preload adjusting washer

| Thickness mm (in) | Part number |
|-------------------------------|-------------|
| 3.80 - 3.82 (0.1496 - 0.1504) | 38125-61001 |
| 3.82 - 3.84 (0.1504 - 0.1512) | 38126-61001 |
| 3.84 - 3.86 (0.1512 - 0.1520) | 38127-61001 |
| 3.86 - 3.88 (0.1520 - 0.1528) | 38128-61001 |
| 3.88 - 3.90 (0.1528 - 0.1535) | 38129-61001 |
| 3.90 - 3.92 (0.1535 - 0.1543) | 38130-61001 |
| 3.92 - 3.94 (0.1543 - 0.1551) | 38131-61001 |
| 3.94 - 3.96 (0.1551 - 0.1559) | 38132-61001 |
| 3.96 - 3.98 (0.1559 - 0.1567) | 38133-61001 |
| 3.98 - 4.00 (0.1567 - 0.1575) | 38134-61001 |
| 4.00 - 4.02 (0.1575 - 0.1583) | 38135-61001 |
| 4.02 - 4.04 (0.1583 - 0.1591) | 38136-61001 |
| 4.04 - 4.06 (0.1591 - 0.1598) | 38137-61001 |
| 4.06 - 4.08 (0.1598 - 0.1606) | 38138-61001 |
| 4.08 - 4.10 (0.1606 - 0.1614) | 38139-61001 |

Available drive pinion bearing preload adjusting spacer

| Length mm (in) | Part number |
|----------------|-------------|
| 55.10 (2.1693) | 38165-B4002 |
| 55.40 (2.1811) | 38165-B4003 |
| 55.70 (2.1929) | 38165-B4004 |
| 56.00 (2.2047) | 38165-61001 |
| 56.25 (2.2146) | 38166-61001 |

SERVICE DATA AND SPECIFICATIONS (S.D.S.)

Final Drive (Cont'd)

Total preload adjustment

| | |
|---------------|----------------------------------------------------------------------------------------------------------|
| Total preload | Value more than 0.29 N·m (3,0 kg-cm, 2.6 in-lb) added on measured value of drive pinion preload |
|---------------|----------------------------------------------------------------------------------------------------------|

Available side gear thrust washer

| Thickness | mm (in) | Part number |
|-------------|-------------------|-------------|
| 0.75 - 0.80 | (0.0295 - 0.0315) | 38424-E3000 |
| 0.80 - 0.85 | (0.0315 - 0.0335) | 38424-E3001 |
| 0.85 - 0.90 | (0.0335 - 0.0354) | 38424-E3002 |
| 0.90 - 0.95 | (0.0354 - 0.0374) | 38424-E3003 |

Side bearing adjustment

| Side bearing adjusting method | Adjusting shim |
|------------------------------------------------------------------------------------------------------------|-------------------------------|
| Side gear to pinion mate gear backlash (Clearance between side gear to differential case) mm (in) | 0.03 - 0.09 (0.0012 - 0.0035) |

Ring gear runout

| | | |
|------------------------|---------|---------------|
| Ring gear runout limit | mm (in) | 0.05 (0.0020) |
|------------------------|---------|---------------|

Available side bearing adjusting washer

| Thickness | mm (in) | Part number |
|-----------|----------|-------------|
| 2.00 | (0.0787) | 38453-N3100 |
| 2.05 | (0.0807) | 38453-N3101 |
| 2.10 | (0.0827) | 38453-N3102 |
| 2.15 | (0.0846) | 38453-N3103 |
| 2.20 | (0.0866) | 38453-N3104 |
| 2.25 | (0.0886) | 38453-N3105 |
| 2.30 | (0.0906) | 38453-N3106 |
| 2.35 | (0.0925) | 38453-N3107 |
| 2.40 | (0.0945) | 38453-N3108 |
| 2.45 | (0.0965) | 38453-N3109 |
| 2.50 | (0.0984) | 38453-N3110 |
| 2.55 | (0.1004) | 38453-N3111 |
| 2.60 | (0.1024) | 38453-N3112 |
| 2.65 | (0.1043) | 38453-N3113 |

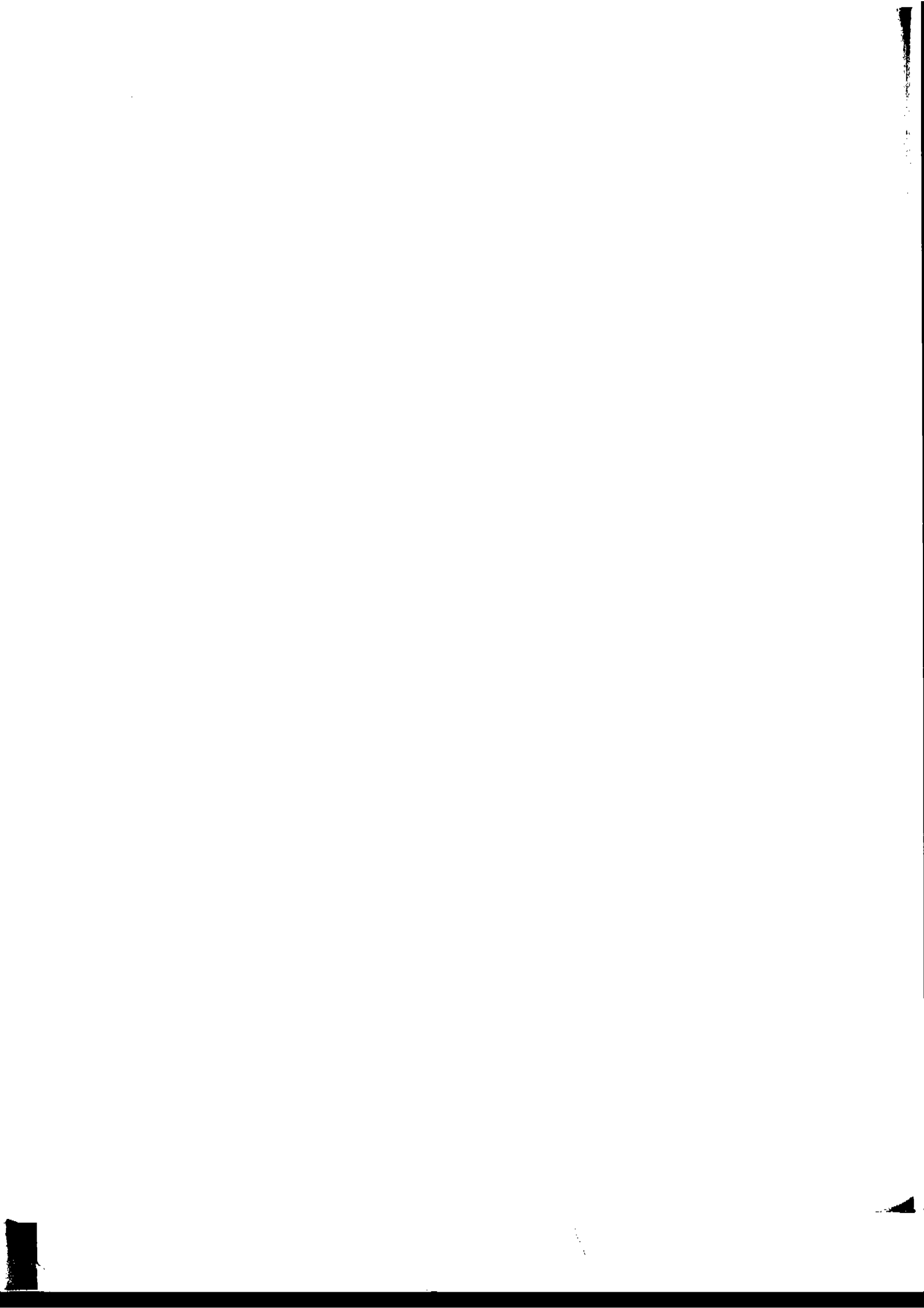

FRONT AXLE & FRONT SUSPENSION

SECTION **FA**

CONTENTS

| | |
|---------------------------------------------------------------|-------|
| PRECAUTIONS AND PREPARATION | FA- 2 |
| FRONT AXLE AND FRONT SUSPENSION | FA- 4 |
| CHECK AND ADJUSTMENT — On-vehicle | FA- 5 |
| FRONT AXLE | FA- 9 |
| FRONT AXLE — Wheel Hub and Knuckle | FA-10 |
| FRONT AXLE — Baffle Plate | FA-13 |
| FRONT SUSPENSION | FA-14 |
| FRONT SUSPENSION — Coil Spring and Strut Assembly | FA-15 |
| FRONT SUSPENSION — Tension Rod and Stabilizer Bar | FA-17 |
| FRONT SUSPENSION — Transverse Link and Lower Ball Joint | FA-18 |
| SERVICE DATA AND SPECIFICATIONS (S.D.S.) | FA-19 |

FA

PRECAUTIONS AND PREPARATION

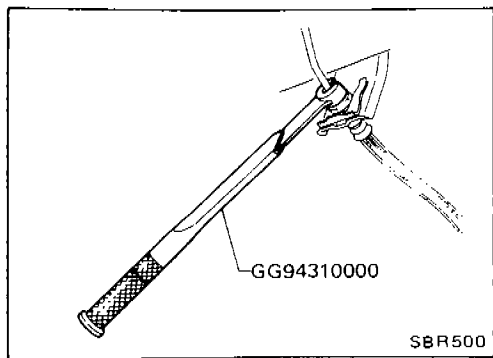

Precautions

- When installing each rubber part, final tightening must be carried out under unladen condition* with tires on ground.
- * Fuel, radiator coolant and engine oil full. Spare tire, jack, hand tools and mats in designated positions.
- When removing each suspension part, check wheel alignment and adjust if necessary.
- Use Tool when removing or installing brake tubes.

Preparation

SPECIAL SERVICE TOOLS

*: Special tool or commercial equivalent

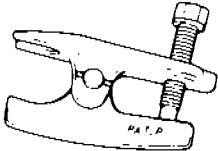
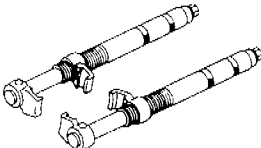
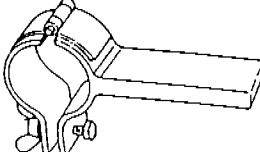
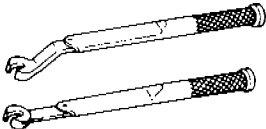
| Tool number Tool name | Description |
|----------------------------------------|------------------------------------------------------------------------------------------------------------------------------------------|
| HT72520000* Ball joint remover |  <p>Removing tie-rod outer end and lower ball joint</p> |
| HT71780000* Spring compressor |  <p>Removing and installing coil spring</p> |
| ST35652000* Strut attachment |  <p>Fixing strut assembly</p> |
| GG94310000* Flare nut torque wrench |  <p>Removing and installing brake piping</p> |

PRECAUTIONS AND PREPARATION

Preparation (Cont'd) COMMERCIAL SERVICE TOOLS

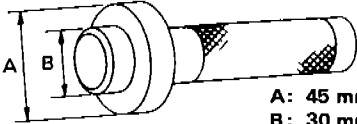
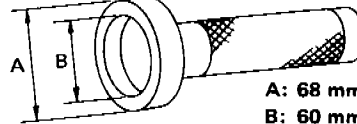
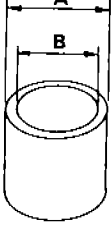
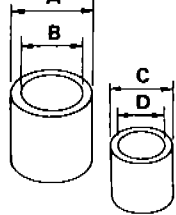
| Tool name | Description |
|---------------------------|---------------------------------------------------------------------------------------------------------------------------------------------------------------------------------------------------------------------------------------------------------------------------------------------------------------------------------------------------------------------------------------------------------------------------|
| Wheel bearing drift | <div style="display: flex; align-items: center; justify-content: center;">  <div style="margin-left: 20px;"> <p>A: 45 mm (1.77 in) dia. B: 30 mm (1.18 in) dia.</p> </div> </div> <p style="text-align: right;">Removing wheel bearing</p> |
| Wheel bearing drift | <div style="display: flex; align-items: center; justify-content: center;">  <div style="margin-left: 20px;"> <p>A: 68 mm (2.68 in) dia. B: 60 mm (2.36 in) dia.</p> </div> </div> <p style="text-align: right;">Installing wheel bearing</p> |
| Baffle plate drift | <div style="display: flex; align-items: center; justify-content: center;">  <div style="margin-left: 20px;"> <p>A: 88 mm (3.46 in) dia. B: 68 mm (2.68 in) dia.</p> </div> </div> <p style="text-align: right;">Installing baffle plate</p> |
| Tension rod bushing drift | <div style="display: flex; align-items: center; justify-content: center;">  <div style="margin-left: 20px;"> <p>A: 75 mm (2.95 in) dia. B: 66 mm (2.60 in) dia. C: 62 mm (2.44 in) dia. D: 25 - 55 mm (0.98 - 2.17 in) dia.</p> </div> </div> <p style="text-align: right;">Removing and installing tension rod bushing</p> |

FRONT AXLE AND FRONT SUSPENSION

Final tightening for rubber parts requires to be carried out under unladen condition* with tires on ground.

* Fuel, radiator coolant and engine oil full.
Spare tire, jack, hand tools and mats in designated positions.

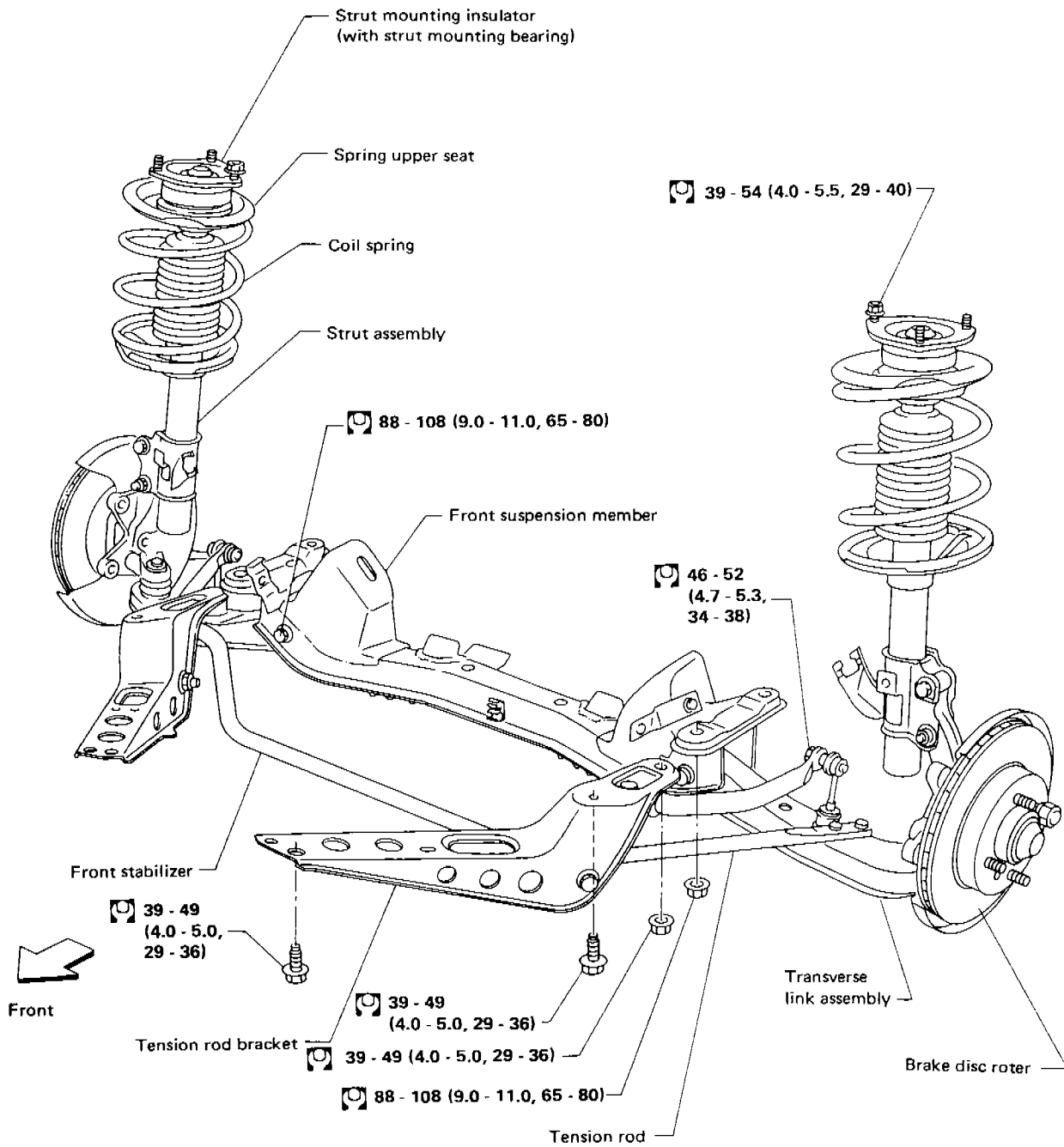

: N·m (kg·m, ft·lb)

SFA540A

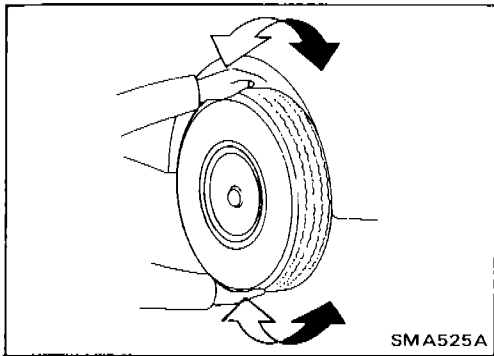

Front Axle and Front Suspension Parts

- Check front axle and front suspension parts for looseness, cracks, wear or other damage.
- (1) Shake each front wheel.

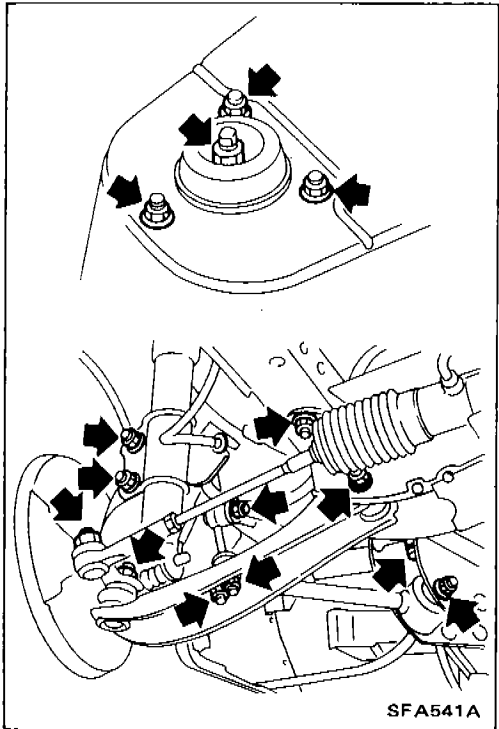

- (2) Retighten all nuts and bolts to the specified torque.
Tightening torque: Refer to pages FA-4, 14.
- (3) Make sure that cotter pin is inserted.
- (4) Check front axle and front suspension parts for wear, cracks or other damage.

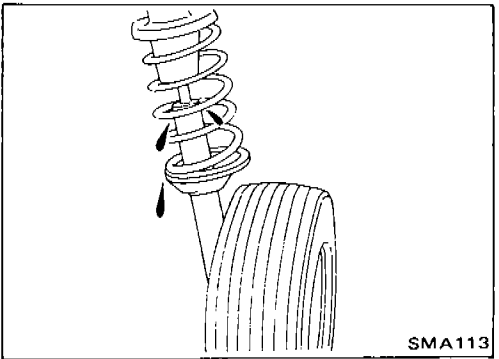

- Check strut (shock absorber) for oil leakage or other damage.

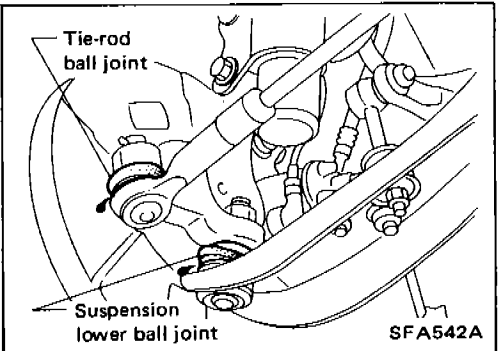

- Check suspension ball joint for grease leakage and ball joint dust cover for cracks or other damage.

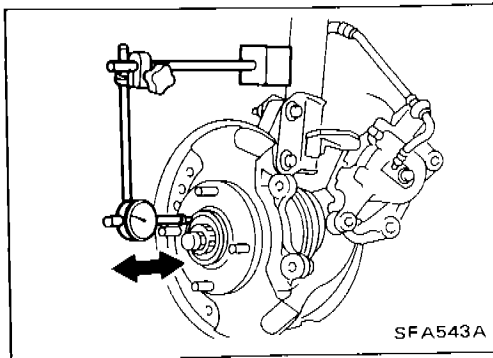

Front Wheel Bearing

- Check tightening torque of wheel bearing lock nut.
 \square : 147 - 216 N·m
 (15 - 22 kg-m, 108 - 159 ft-lb)
- Check that wheel bearings operate smoothly.
- Check axial end play.
Axial end play: 0.03 mm (0.0012 in) or less
- If axial end play is not within specification or wheel bearing does not turn smoothly, replace wheel bearing assembly. Refer to FRONT AXLE — Wheel Hub and Knuckle.

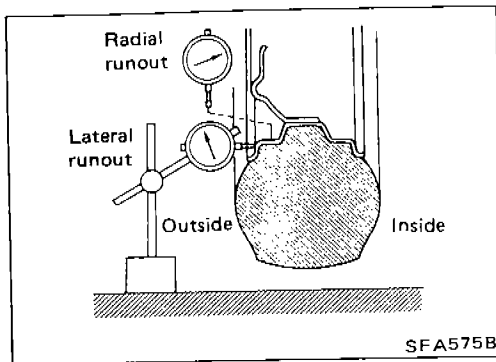

Front Wheel Alignment

Before checking front wheel alignment, be sure to make a preliminary inspection.

PRELIMINARY INSPECTION

Make following checks. Adjust, repair or replace if necessary.

- Check tires for wear and improper inflation.
- Check front wheel bearings for looseness.
- Check wheel runout.

Refer to S.D.S.

- Check front suspension for looseness.
- Check steering linkage for looseness.
- Check that front shock absorbers work properly.
- Check vehicle posture (Unladen):
 "Unladen"

Fuel, radiator coolant and engine oil full. Spare tire, jack, hand tools and mats in designated positions.

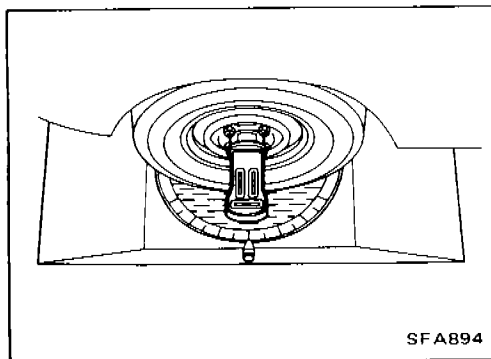

CAMBER, CASTER AND KINGPIN INCLINATION

- Caster and kingpin inclination are preset at factory and cannot be adjusted.
- Measure camber, caster and kingpin inclination of both right and left wheels with a suitable alignment gauge, and adjust in accordance with the following procedures.

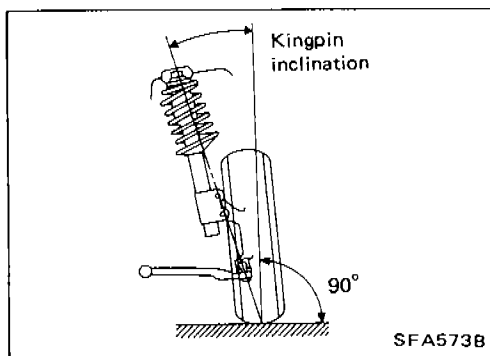

Kingpin inclination:
 $12^{\circ}25'$ - $13^{\circ}55'$

CHECK AND ADJUSTMENT — On-vehicle

Front Wheel Alignment (Cont'd)

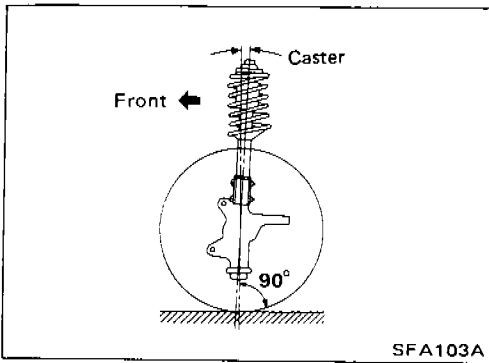

Caster:
 $5^{\circ}55' - 7^{\circ}25'$

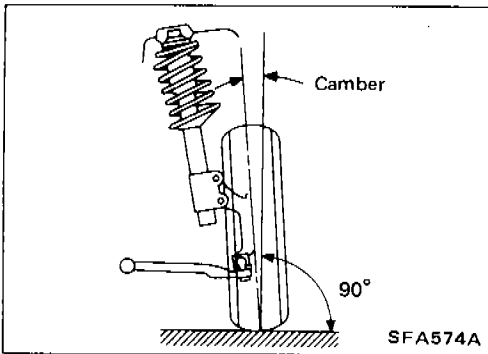

Camber:
 $-1^{\circ}25' \text{ to } 5'$

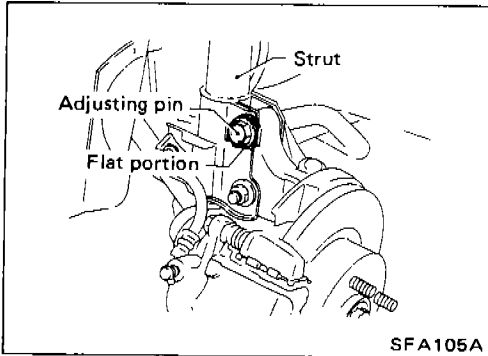

If camber is not within specification, adjust by turning adjusting pin as follows:

(1) Remove adjusting pin

Adjusting pin is installed with flat portion facing downward.

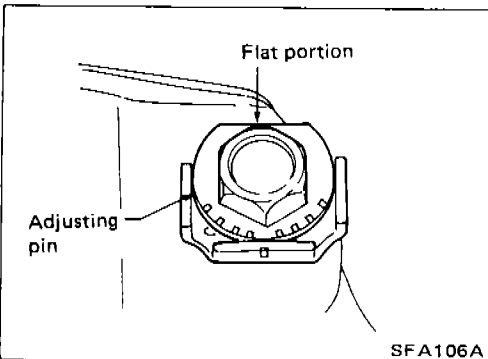

(2) Next replace adjusting pin with flat portion facing upward.

(3) Turn adjusting pin to adjust.

Camber changes about 5' with each graduation of adjusting pin.

(4) Tighten adjusting pin to specified torque.

\square : 124 - 143 N·m (12.6 - 14.6 kg·m, 91 - 106 ft·lb)

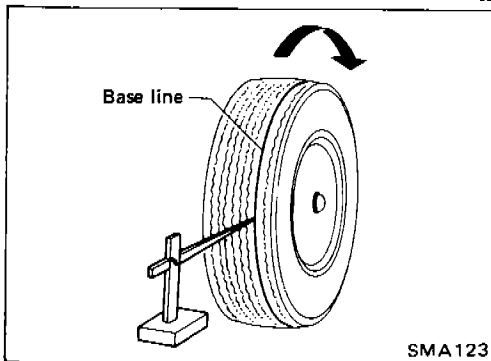

TOE-IN

1. Draw a base line on tread surface of tires.

After lowering front of vehicle, move it up and down to eliminate friction, and set steering wheel in straight-ahead position.

CHECK AND ADJUSTMENT — On-vehicle

Front Wheel Alignment (Cont'd)

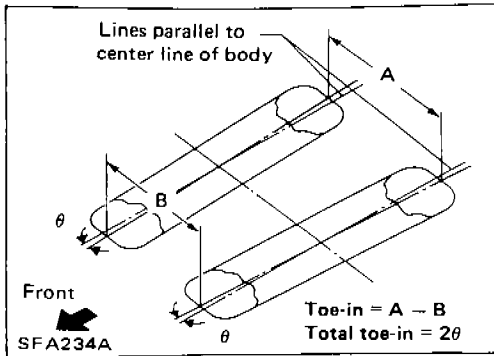

2. Measure toe-in.

Measure distance "A" and "B" at same height as hub center.

Toe-in:

$$A - B \quad 0 - 2 \text{ mm (0 - 0.08 in)}$$

$$2 \theta \text{ (Total toe-in) } 0' \text{ to } 12'$$

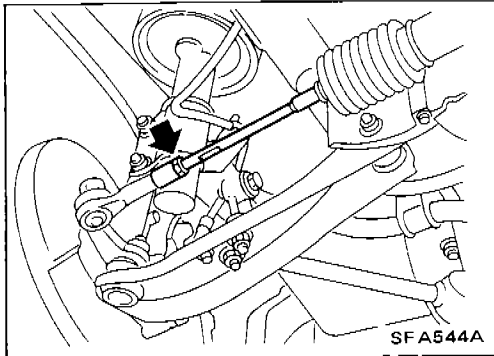

3. Adjust toe-in by varying length of steering tie-rods.

(1) Loosen lock nuts.

(2) Adjust toe-in by turning forward and reverse tie-rod.

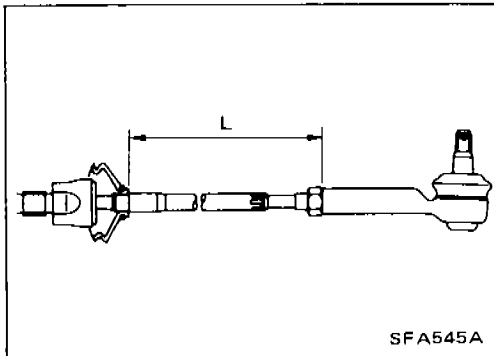

Make sure both tie-rods are the same length.

Standard length "L" — reference data:

$$174.8 \text{ mm (6.88 in)}$$

(3) Fix lock nuts, then tighten them designed torque.

$$\square: 37 - 46 \text{ N}\cdot\text{m}$$

$$(3.8 - 4.7 \text{ kg}\cdot\text{m, } 27 - 34 \text{ ft}\cdot\text{lb})$$

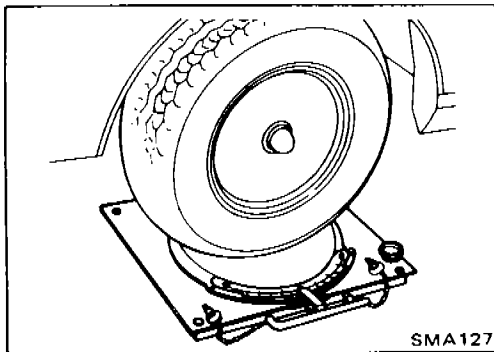

FRONT WHEEL TURNING ANGLE

1. Set wheels in straight-ahead position and then move vehicle forward until front wheels rest on turning radius gauge properly.

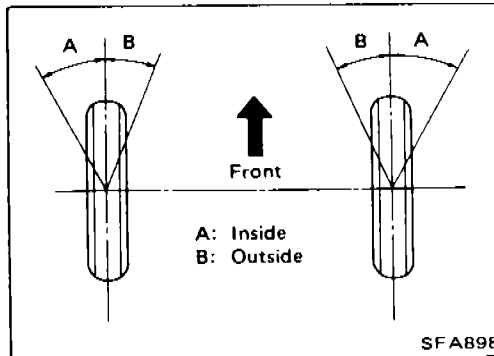

2. Rotate fully steering wheel to the right or left; measure turning angle.

Wheel turning angle:

| | | | |
|------------|----------------------------|------------------|-----------|
| Full turns | Except Europe L.H.D. model | Inside wheel: A | 39° - 43° |
| | | Outside wheel: B | 33° |
| | Europe L.H.D. model | Inside wheel: A | 36° - 40° |
| | | Outside wheel: B | 32° |

FRONT AXLE

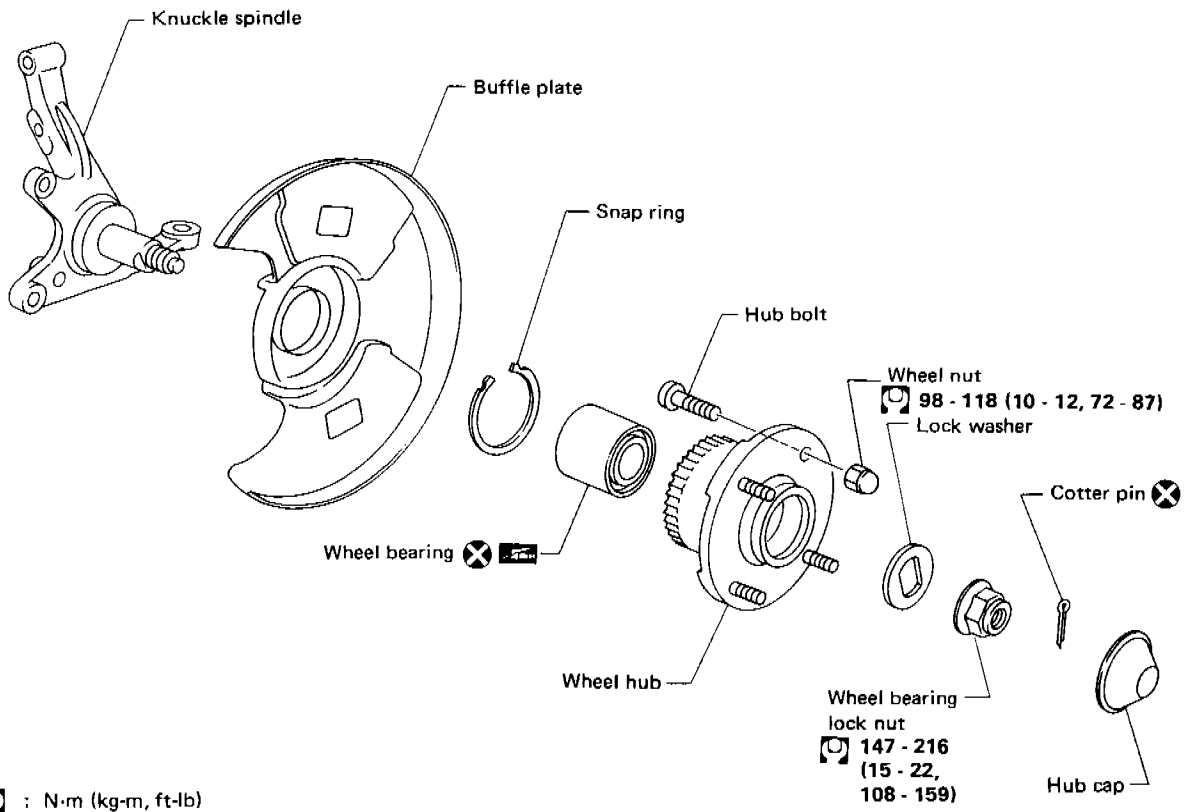

SFA546A

FRONT AXLE — Wheel Hub and Knuckle

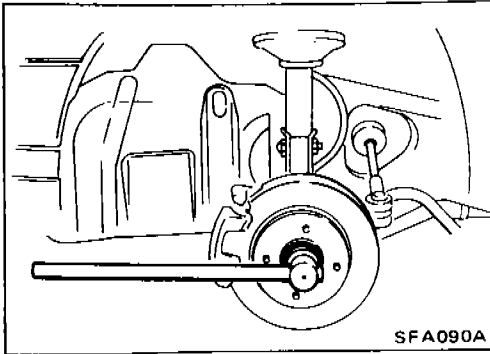

Removal

- Remove wheel bearing lock nut.

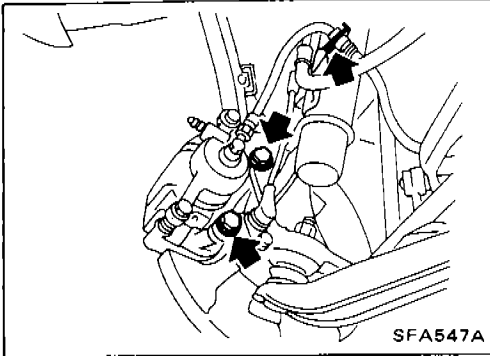

- Remove brake caliper assembly.
Brake hose need not be disconnected from brake caliper. Be careful not to depress brake pedal, or piston will pop out. Make sure brake hose is not twisted.

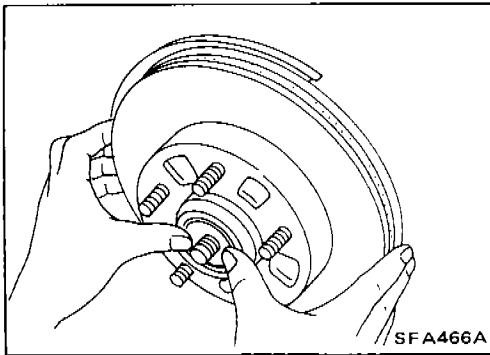

- Remove rotor and wheel hub from spindle.

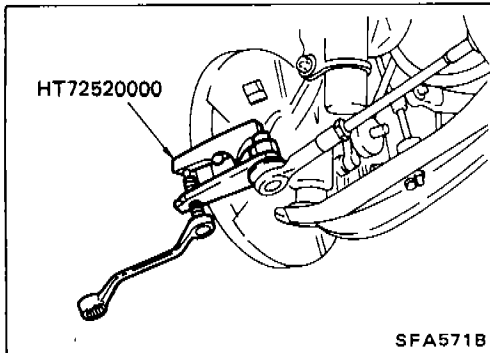

- Remove tie-rod ball joint and lower ball joint.

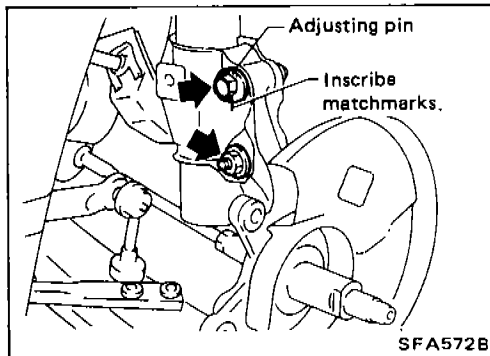

- Remove bolts and nuts as shown at left.
Make matchmarks before removing adjusting pin.

FRONT AXLE — Wheel Hub and Knuckle

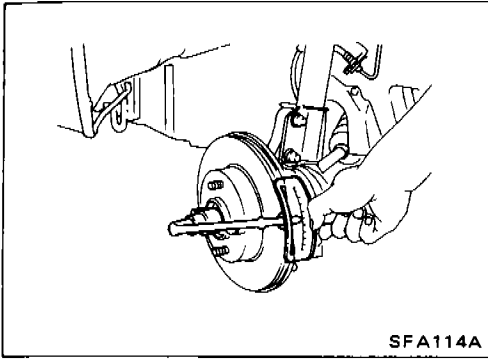

Installation

- Install wheel hub.
- Tighten wheel bearing lock nut.
Ⓜ: 147 - 216 N·m
(15 - 22 kg-m, 108 - 159 ft-lb)

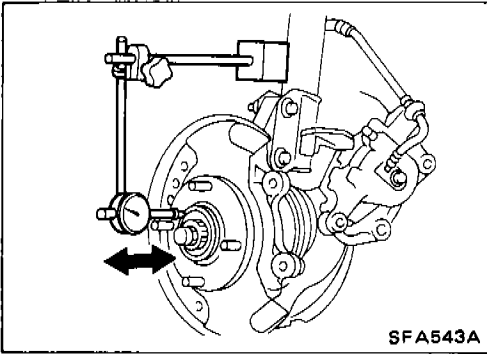

- Check wheel bearing axial end play.
Axial end play: 0.03 mm (0.0012 in) or less

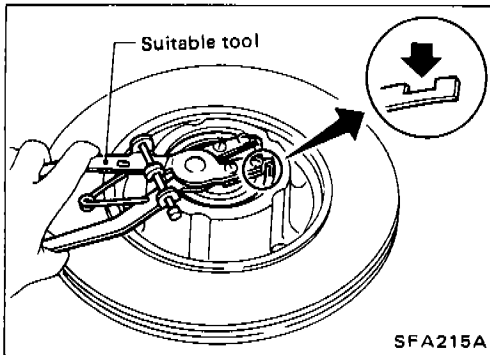

Disassembly

CAUTION:

When removing wheel bearing from wheel hub, replace wheel bearing assembly (outer race, inner races and grease seal) with a new one.

- Remove circular clip with suitable tool.

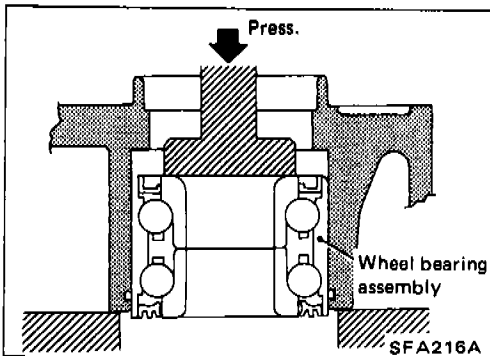

- Press out wheel bearing assembly from wheel hub.

Inspection

WHEEL HUB

- Check wheel hub for any cracks by using a magnetic exploration or dyeing test.

CIRCULAR CLIP

- Check circular clip for wear or cracks.
Replace if necessary.

FRONT AXLE — Wheel Hub and Knuckle

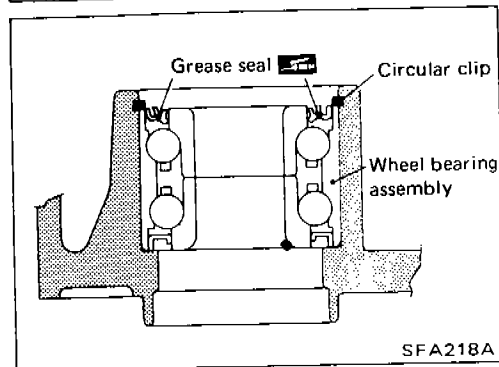
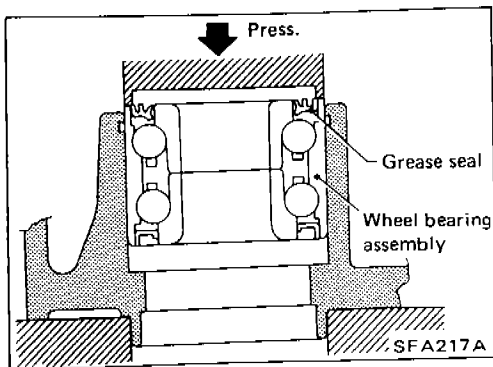

Assembly

1. Press new wheel bearing assembly into wheel hub from inside of rotor disc (with wheel hub).

Maximum load P:

29 kN (3 t, 3.3 US ton, 3.0 Imp ton)

CAUTION:

- Do not press inner race of wheel bearing assembly.
 - Do not apply oil or grease to mating surfaces of wheel bearing outer race and wheel hub.
- Be careful not to damage grease seal.

2. Install circular clip into groove of wheel hub.

3. Apply multi-purpose grease to sealing lip.

FRONT AXLE — Baffle Plate

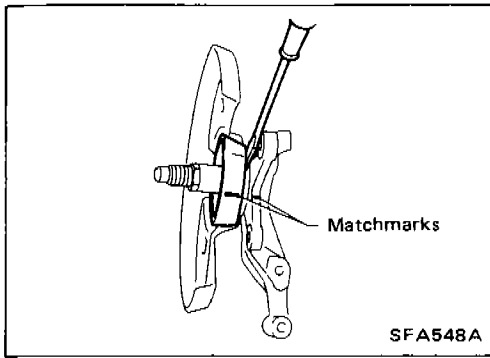

Removal

- Mark matchmarks on baffle plate before removing.
- If baffle plate replacement requires removal of knuckle spindle, separate it equally using a screwdriver.

Be careful not to scratch knuckle spindle.

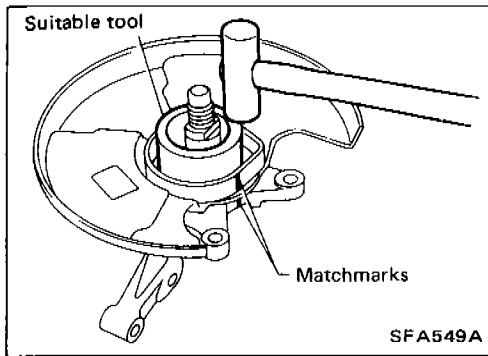

Installation

- Align matchmarks previously marked on baffle plate and install baffle plate by lightly tapping with a copper hammer and suitable tool.

FRONT SUSPENSION

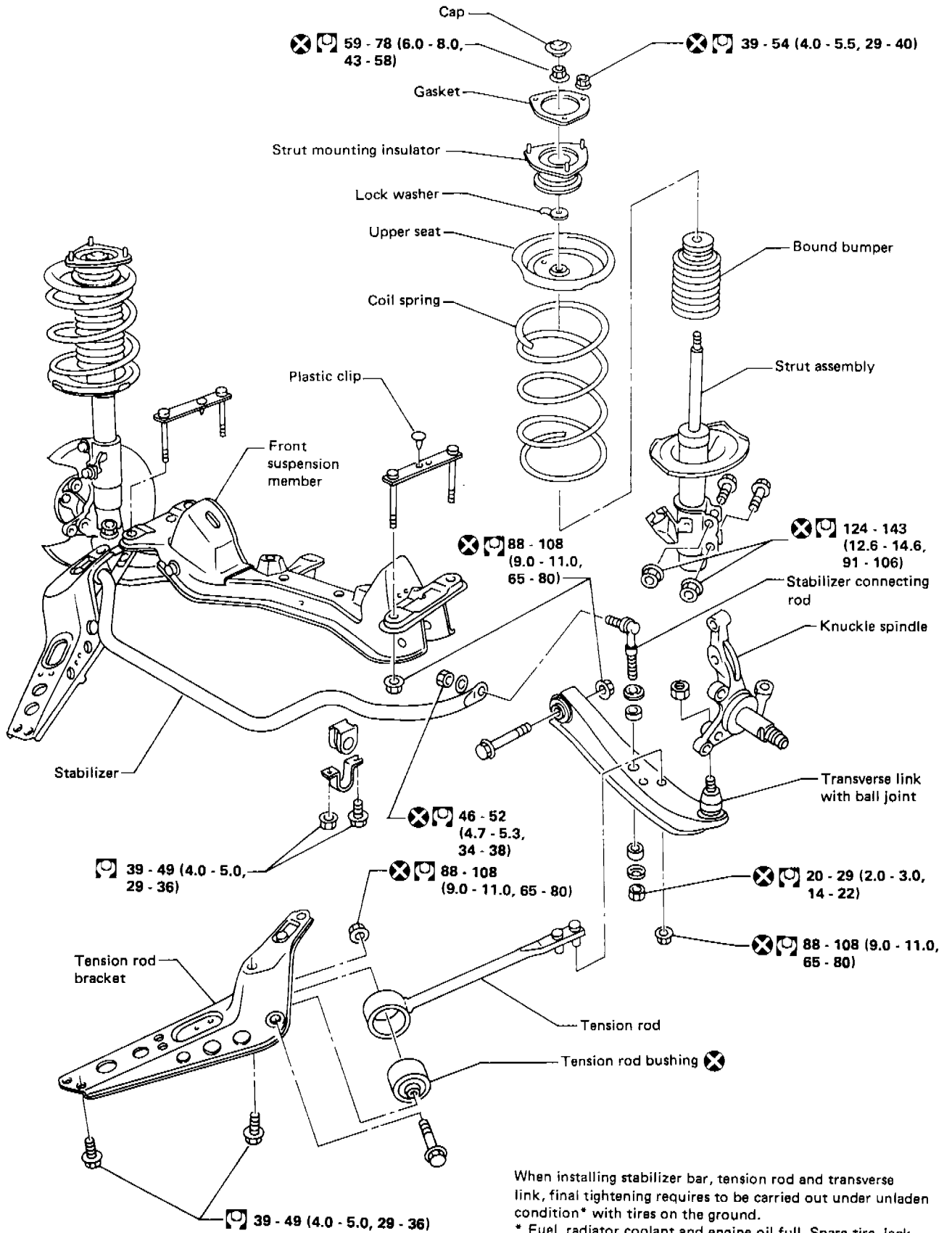

When installing stabilizer bar, tension rod and transverse link, final tightening requires to be carried out under unladen condition* with tires on the ground.

* Fuel, radiator coolant and engine oil full. Spare tire, jack, hand tools and mats in designated position.

: N·m (kg·m, ft·lb)

SFA550A

FRONT SUSPENSION — Coil Spring and Strut Assembly

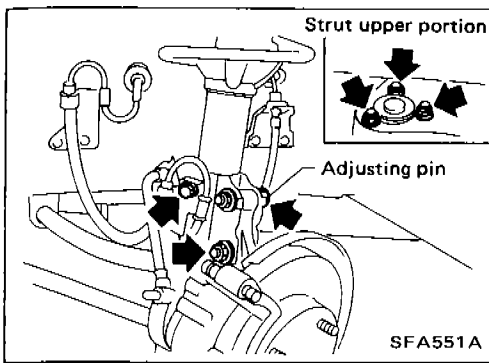

Removal

- Remove strut assembly fixing bolts and nuts (to hoodledge).
- Do not remove piston rod lock nut on vehicle.
- Put matchmarks on strut lower bracket and camber adjusting pin.

Disassembly

1. Set strut assembly on vise with Tool, then loosen piston rod lock nut.

- Do not remove piston rod lock nut.

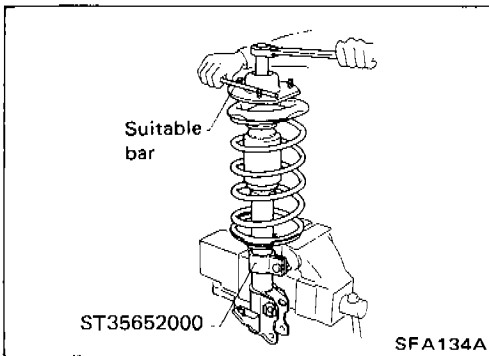

2. Compress spring with a Tool so that strut mounting insulator can be turned by hand.

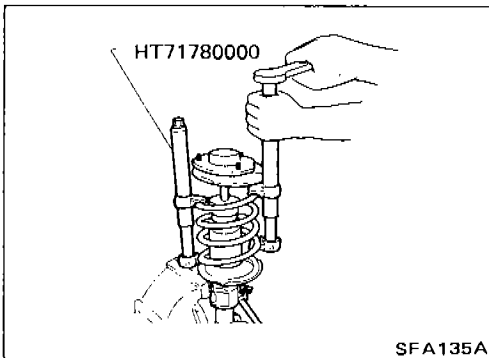

3. Remove piston rod lock nut.

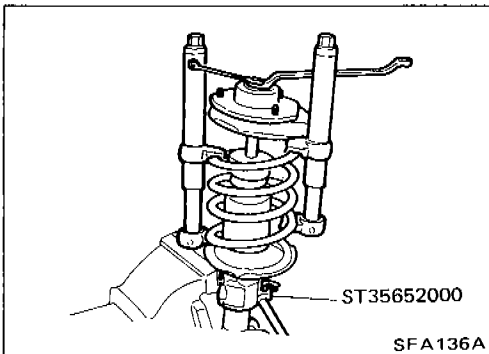

Inspection

STRUT ASSEMBLY

- Check for smooth operation through a full stroke, both compression and extension.
- Check for oil leakage occurring on welded or gland packing portion.
- Check piston rod for cracks, deformation or other damage. Replace if necessary.

FRONT SUSPENSION — Coil Spring and Strut Assembly

Inspection (Cont'd)

STRUT MOUNTING INSULATOR

- Check cemented rubber-to-metal portion for separation or cracks. Check rubber parts for deterioration.
- Check thrust bearing parts for abnormal noise or excessive rattle in axial direction.
Replace if necessary.

LOCK WASHER

- Check for cracks, deformation or other damage. Replace if necessary.

COIL SPRING

- Check for cracks, deformation or other damage. Replace if necessary.

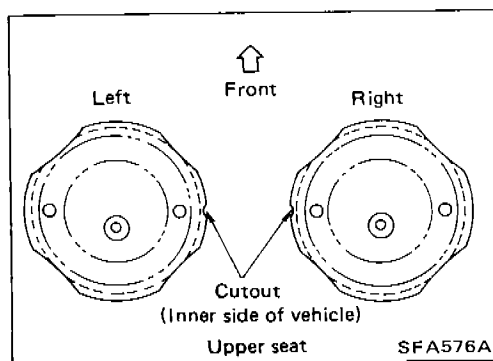
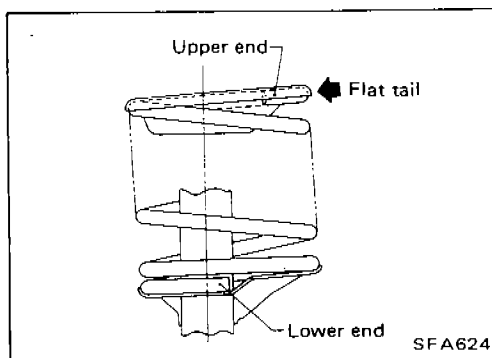
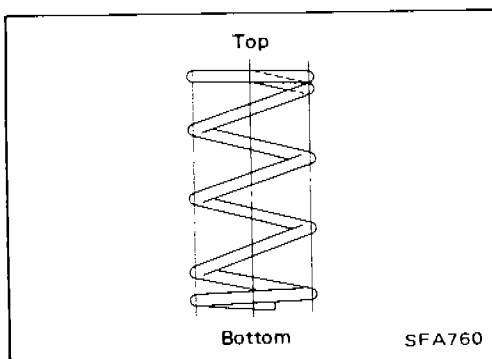

Assembly

- When installing coil spring, be careful not to reverse top and bottom direction. (Top end is flat.)
- When installing coil spring on strut, it must be positioned as shown in figure at left.
- Install upper spring seat with its cutout facing the inner side of vehicle.

FRONT SUSPENSION — Tension Rod and Stabilizer Bar

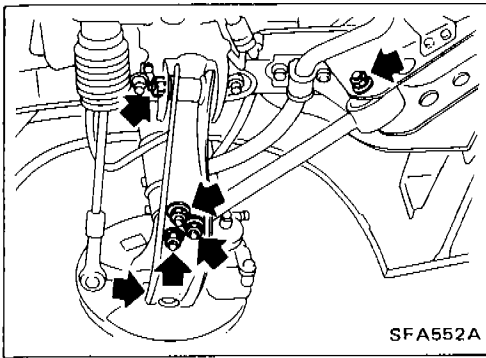

Removal and Installation

- Remove tension rod and stabilizer bar.

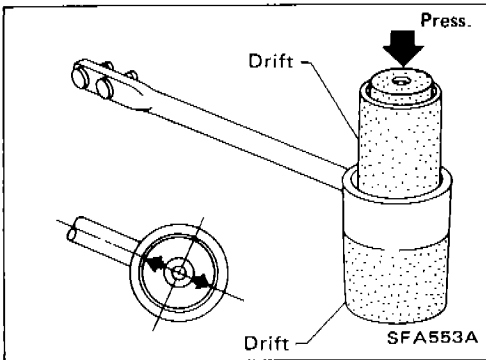

- When removing tension rod bushing, place one drift on lower side of bushing and the other on upper side, as shown at left, and press bushing out.
- Place arrow mark on bushing facing tension rod before installing bushing.

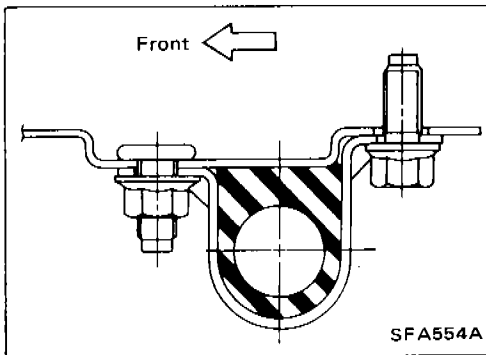

- Install stabilizer rear side bushings, then install front side bushings.

When installing stabilizer bar clamp, make sure direction is correct (as shown at left.)

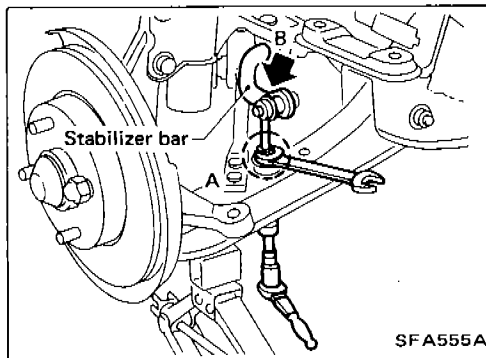

- When removing and installing stabilizer bar, fix portion A.

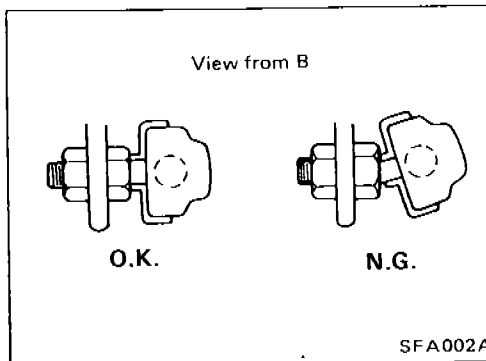

- Install stabilizer bar with ball joint socket properly placed.

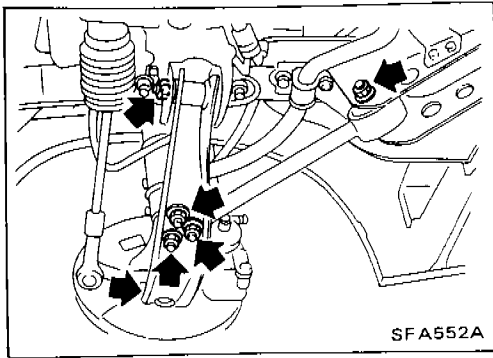

Removal and Installation

- Remove stabilizer, tension rod, ball joint and transverse link assembly.
- During installation, final tightening must be carried out at curb weight with tires on ground.
- After installation, check wheel alignment. Refer to "Front Wheel Alignment" of CHECK AND ADJUSTMENT — On-vehicle.

Inspection

TRANSVERSE LINK

- Check transverse link for damage, cracks or deformation. Replace it if necessary.
- Check rubber bushing for damage, cracks and deformation. Replace transverse link if necessary.

LOWER BALL JOINT

- Check ball joint for play. If ball stud is worn, play in axial direction is excessive or joint is hard to swing, replace transverse link assembly if necessary.

Swing force and turning torque

Before checking, turn ball joint at least 10 revolutions so that ball joint is properly broken in.

Swing force:

(measure point: cotter pin hole of ball stud)

7.8 - 55.9 N (0.8 - 5.7 kg, 1.8 - 12.6 lb)

Turning torque:

0.49 - 3.43 N·m (5.0 - 35 kg-cm, 4.3 - 30.4 in-lb)

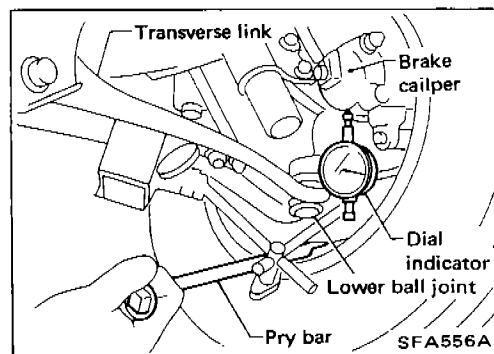
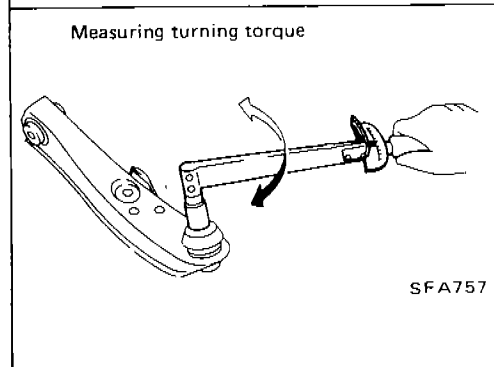
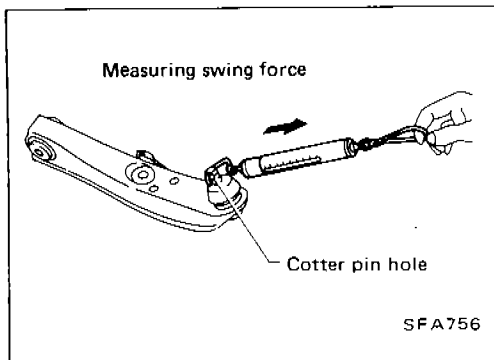

Vertical end play (On-vehicle)

- (1) Jack up front of vehicle and set the stands.
- (2) Clamp dial indicator onto transverse link and place indicator tip on lower edge of brake caliper.
- (3) Make sure front wheels are straight and brake pedal is depressed.
- (4) Place a pry bar between transverse link and inner rim of road wheel.
- (5) While pushing and releasing pry bar, observe maximum dial indicator value.

Vertical end play: 0 mm (0 in)

- (6) If not within above specification, replace transverse link.

SERVICE DATA AND SPECIFICATIONS (S.D.S.)

General Specifications

COIL SPRING

| Item | Model | |
|----------------------------------------|----------|------------------------------|
| | Europe | Except Europe |
| Wire diameter | mm (in) | 12.7 (0.500) |
| Coil diameter | mm (in) | 170 (6.69) |
| Free length | mm (in) | 360 (14.17) 350 (13.78) |
| Spring constant N/mm (kg/mm, lb/in) | | 15.7 (1.6, 90) |
| Identification color | Pink x 1 | Yellow x 1 |

FRONT STABILIZER BAR

| | | |
|----------------------|---------|-----------|
| Stabilizer diameter | mm (in) | 25 (0.98) |
| Identification color | | Orange |

STRUT

| | | |
|---------------------------------------------------------|---------|-----------------------------------|
| Piston rod diameter | mm (in) | 20.0 (0.787) |
| Stroke | mm (in) | 160 (6.30) |
| Damping force [at 0.3 m (1.0 ft)/sec.] N (kg, lb) | | |
| Expansion | | 912 - 1,245 (93 - 127, 205 - 280) |
| Compression | | 392 - 588 (40 - 60, 88 - 132) |

SERVICE DATA AND SPECIFICATIONS (S.D.S.)

Inspection and Adjustment

WHEEL ALIGNMENT (Unladen*1)

| | | |
|-------------------------------|---------|------------------------------------|
| Camber | degree | -1°25' to 5' |
| Caster | degree | 5°55' - 7°25' |
| Toe-in (Total) | mm (in) | 0 - 2 (0 - 0.08) |
| | degree | 0' - 12' |
| Kingpin inclination | degree | 12°25' - 13°55' |
| Front wheel turning angle | | |
| Full turn*2 inside/outside | degree | 36° - 40°/32°*3 39° - 43°/33°*4 |

*1: Tankful of fuel, radiator coolant and engine oil full. Spare tire, jack, hand tools, mats in designated position.

*2: On power steering models, wheel turning force (at circumference of steering wheel) of 98 to 147 N (10 to 15 kg, 22 to 33 lb) with engine idle.

*3: Europe L.H.D. model

*4: Except Europe L.H.D. model

WHEEL BEARING

| | |
|------------------------------------------------------------------|--------------------------------|
| Wheel bearing axial end play mm (in) | 0.03 (0.0012) or less |
| Wheel bearing lock nut Tightening torque N-m (kg-m, ft-lb) | 147 - 216 (15 - 22, 108 - 159) |

LOWER BALL JOINT

| | | |
|-------------------------------------------------------------------|--------------------|---------------------------------------|
| Swing force (Measuring point: cotter pin hole of ball stud) | N (kg, lb) | 7.8 - 55.9 (0.8 - 5.7, 1.8 - 12.6) |
| Turning torque | N-m (kg-cm, in-lb) | 0.49 - 3.43 (5.0 - 35, 4.3 - 30.4) |
| Vertical end play | mm (in) | 0 (0) |

WHEEL RONOUT (Radial and lateral)

| Wheel type | Radial runout | Lateral runout |
|---------------------------|---------------------|---------------------|
| Aluminum wheel mm (in) | 0.3 (0.012) or less | |
| Steel wheel mm (in) | 0.5 (0.020) or less | 0.8 (0.031) or less |

REAR AXLE & REAR SUSPENSION

SECTION **RA**

CONTENTS

| | |
|---------------------------------------------------------|-------|
| PRECAUTIONS AND PREPARATION | RA- 2 |
| REAR AXLE AND REAR SUSPENSION | RA- 4 |
| CHECK AND ADJUSTMENT — On-vehicle | RA- 5 |
| REAR AXLE AND REAR SUSPENSION ASSEMBLY | RA- 8 |
| REAR AXLE — Wheel Hub and Axle Housing | RA- 9 |
| REAR AXLE — Drive Shaft | RA-13 |
| REAR SUSPENSION | RA-19 |
| REAR SUSPENSION — Coil Spring and Shock Absorber | RA-20 |
| REAR SUSPENSION — Stabilizer Bar | RA-22 |
| REAR SUSPENSION — Multi-link and Lower Ball Joint | RA-23 |
| SERVICE DATA AND SPECIFICATIONS (S.D.S.) | RA-24 |

RA

PRECAUTIONS AND PREPARATION

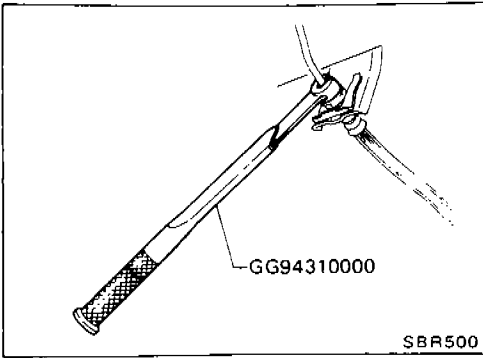

Precautions

- When installing each rubber part, final tightening must be carried out under unladen condition* with tires on ground.
 - * Fuel, radiator coolant and engine oil full. Spare tire, jack, hand tools, and mats in designated positions.
- Use Tool when removing or installing brake tubes.
- When removing each suspension part, check wheel alignment and adjust if necessary.
- Do not jack up at the lower arm.

Preparation

SPECIAL SERVICE TOOLS

*: Special tool or commercial equivalent

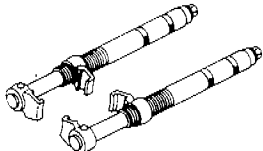
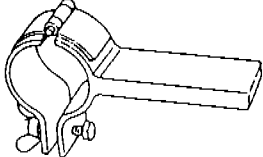
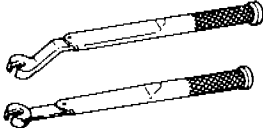
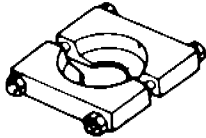
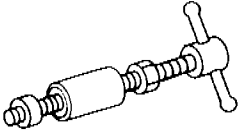
| Tool number Tool name | Description | |
|----------------------------------------|-------------------------------------------------------------------------------------|------------------------------------------------------|
| HT71780000* Spring compressor |  | Removing and installing coil spring |
| ST35652000* Strut attachment |  | Fixing strut assembly |
| GG94310000* Flare nut torque wrench |  | Removing and installing brake piping |
| ST30031000* Bearing puller |  | Removing inner race of wheel bearing |
| ST38280000 Arm bushing remover |  | Removing and installing bushing of rear axle housing |

PRECAUTIONS AND PREPARATION

Preparation (Cont'd)

COMMERCIAL SERVICE TOOLS

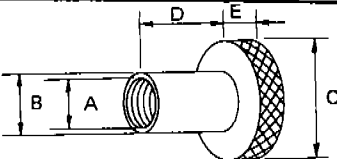
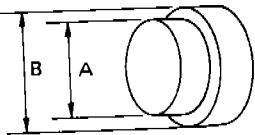
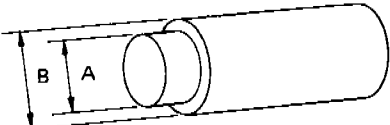
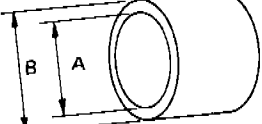
| Tool name | Description |
|-------------------------------------|-------------------------------------------------------------------------------------------------------------------------------------------------------------------------------------------------------------------------------------------------------------------------------------------------------------------------|
| Attachment Wheel alignment |  <p style="text-align: right;">Measure rear wheel alignment</p> <p>A: Screw M24 x 1.5 B: 35 (1.38) dia. C: 65 (2.56) dia. D: 56 (2.20) E: 12 (0.47) Unit: mm (in)</p> |
| Rear wheel hub drift |  <p style="text-align: right;">Installing wheel bearing</p> <p>A: 41 mm (1.61 in) dia. B: 49 mm (1.93 in) dia.</p> |
| Wheel bearing drift |  <p style="text-align: right;">Removing rear wheel hub</p> <p>A: 26 mm (1.02 in) dia. B: 40 mm (1.57 in) dia.</p> |
| Rear drive shaft plug seal drift |  <p style="text-align: right;">Installing rear drive shaft plug seal</p> <p>A: 67 mm (2.64 in) dia. B: 85 mm (3.35 in) dia.</p> |

REAR AXLE AND REAR SUSPENSION

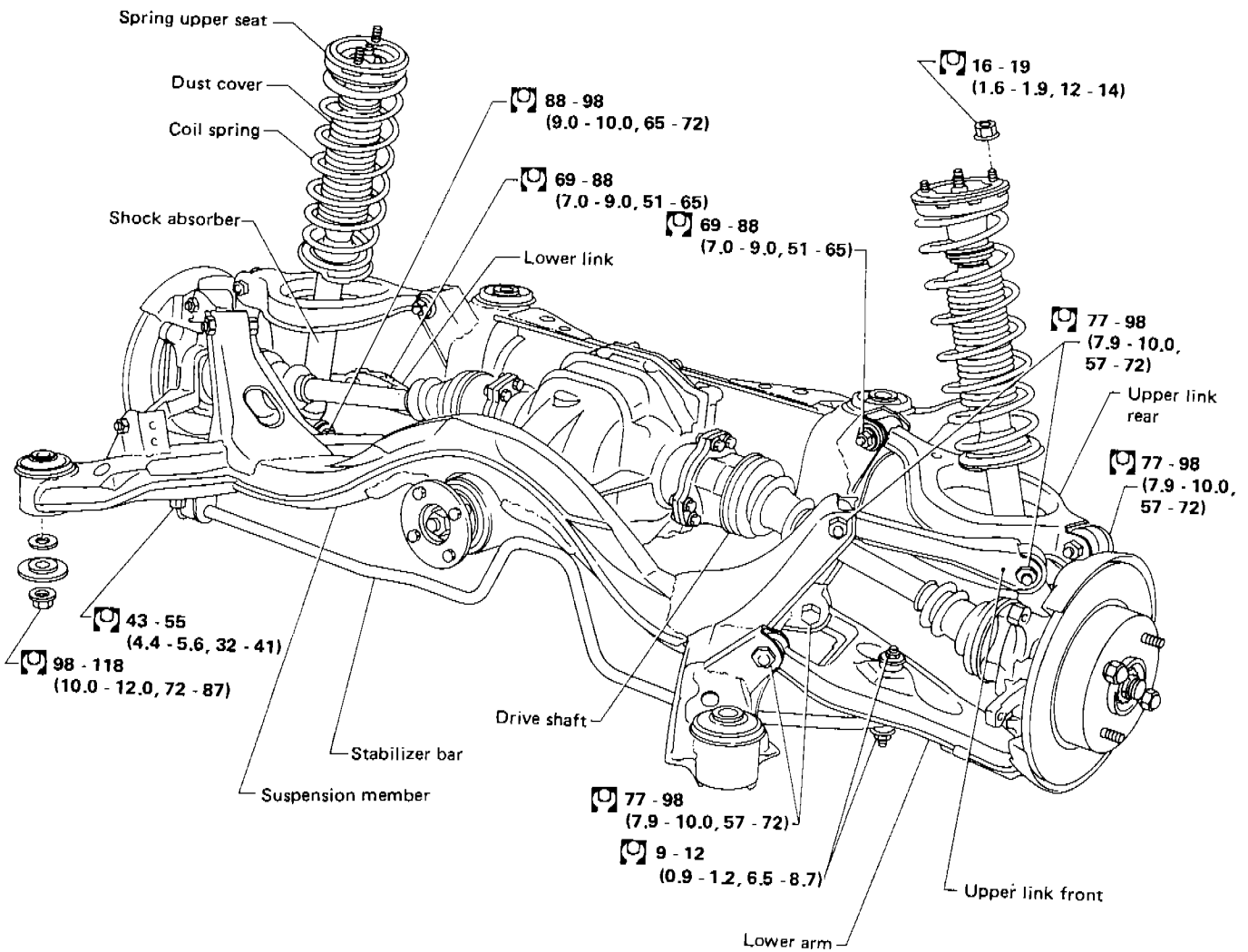

Final tightening for rubber parts requires to be carried out under unladen condition* with tires on ground.

- * Fuel, radiator coolant and engine oil full.
- Spare tire, jack, hand tools and mats in designated positions.

: N-m (kg-m, ft-lb)

SRA093A

Rear Axle and Rear Suspension Parts

- Check axle and suspension parts for looseness, wear or damage.

(1) Shake each rear wheel.

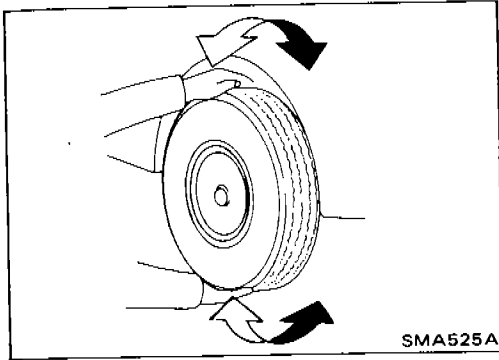

(2) Retighten all nuts and bolts to the specified torque.

Tightening torque:

Refer to pages RA-4, 19.

(3) Make sure that cotter pin is inserted.

(4) Check rear axle and rear suspension parts for wear, cracks or other damage.

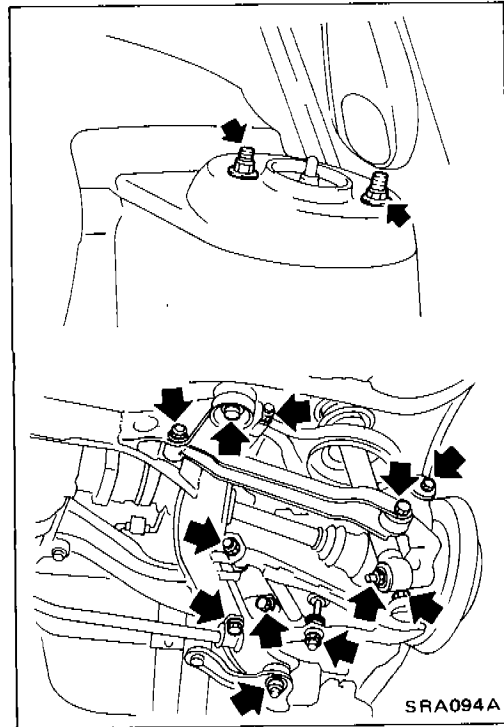

(5) Check shock absorber for oil leakage or other damage.

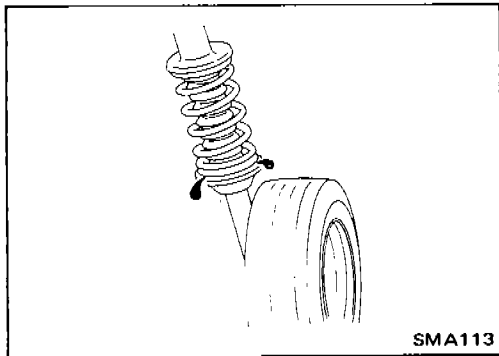

- Check suspension ball joint for grease leakage and ball joint dust cover for cracks or other damage.

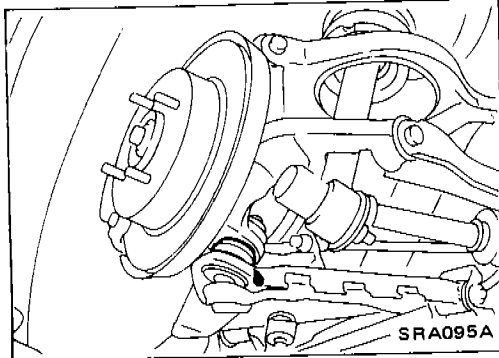

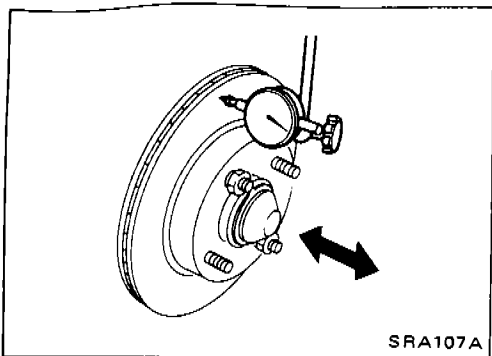

Rear Wheel Bearing

- Check tightening torque of wheel bearing lock nut.
□: 235 - 314 N·m
(24 - 32 kg-m, 174 - 231 ft-lb)
- Check that wheel bearings operates smoothly.
- Check axial end play.

Axial end play:
0.05 mm (0.0020 in) or less

If axial end play is not within specification or wheel bearing does not turn smoothly, replace wheel bearing assembly. Refer to REAR AXLE — Wheel Hub and Axle Housing.

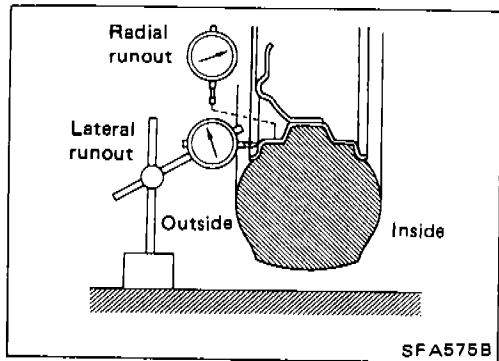

Rear Wheel Alignment

Before checking rear wheel alignment, be sure to make a preliminary inspection.

PRELIMINARY INSPECTION

Make following checks. Adjust, repair or replace if necessary.

- Check tires for wear and for improper inflation.
- Check rear wheel bearings for looseness.
- Check wheel runout.

Refer to S.D.S.

- Check that rear shock absorber works properly.
- Check rear axle and rear suspension parts for looseness.
- Check vehicle posture (Unladen).

"Unladen":

Fuel tank, radiator and engine oil full. Spare tire, jack, hand tools and mats in designated positions.

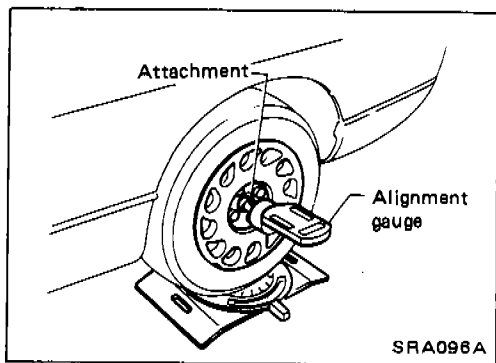

CAMBER

- Measure camber of both right and left wheels with a suitable alignment gauge and adjust in accordance with the following procedures.

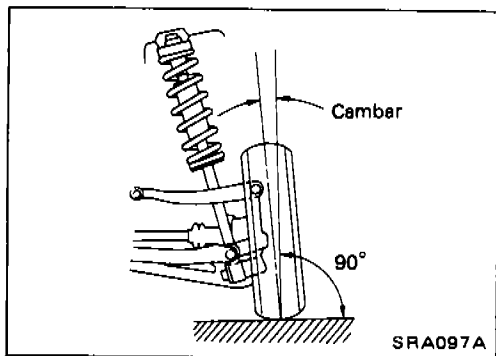

Camber:
-1°40' to -0°40'

CHECK AND ADJUSTMENT — On-vehicle

Rear Wheel Alignment (Cont'd)

If camber is not within specification, adjust by turning the adjusting pin.

- (1) Turn the adjusting pin to adjust.
Camber changes about 5' with each graduation of the adjusting pin.
- (2) Tighten to the specified torque.
☐: 69 - 88 N·m
(7.0 - 9.0 kg-m, 51 - 65 ft-lb)

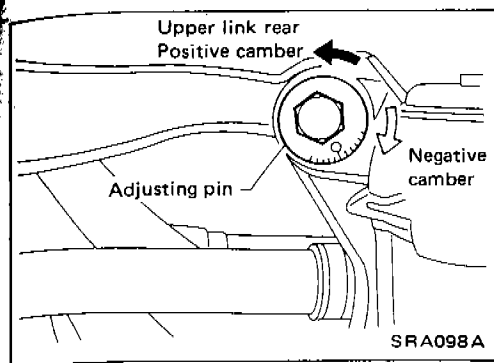

TOE-IN

1. Draw a base line across the tread.
After lowering rear of vehicle, move it up and down to eliminate friction.

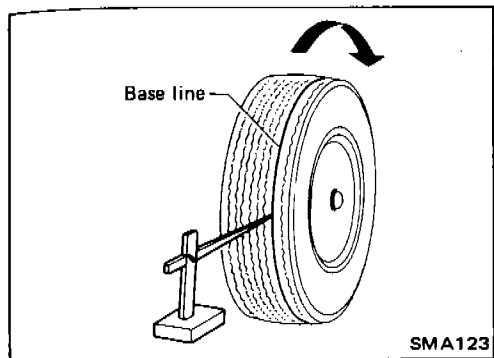

2. Measure toe-in.
Measure distance "A" and "B" at the same height as hub center.

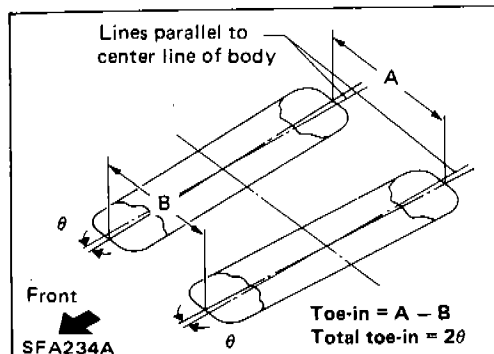

Toe-in:

$$A - B$$
$$0 - 5 \text{ mm (0 - 0.20 in)}$$
$$2 \theta \text{ (Total toe-in)}$$
$$0' - 28'$$

3. Adjust toe-in by turning adjusting pins.
Toe changes about 1.5 mm (0.059 in) [One side] with each graduation of the adjusting pin.
4. Tighten to the specified torque.

☐: 69 - 88 N·m
(7.0 - 9.0 kg-m, 51 - 65 ft-lb)

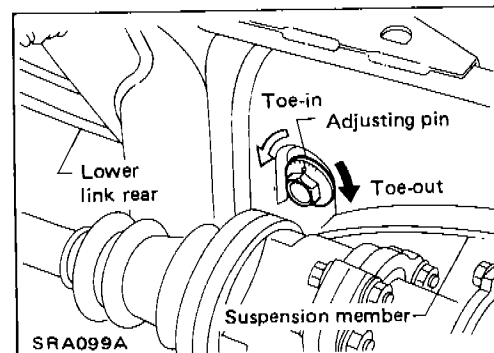

Drive Shaft

Check boot and drive shaft for cracks, wear, damage or grease leakage.

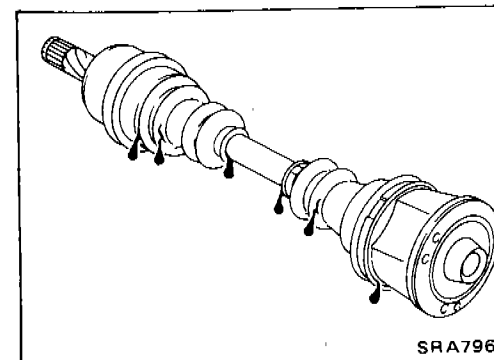

REAR AXLE AND REAR SUSPENSION ASSEMBLY

Removal and Installation

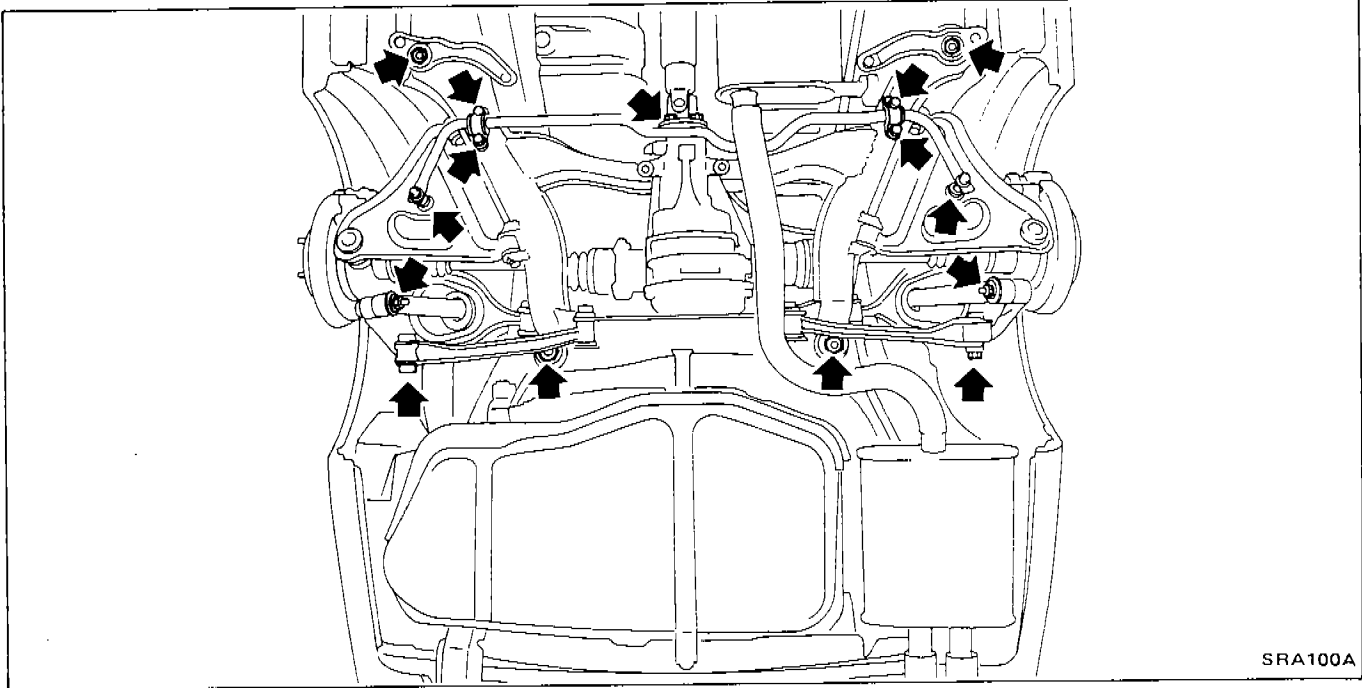

SRA100A

- Remove exhaust tube.
- Disconnect propeller shaft rear end.

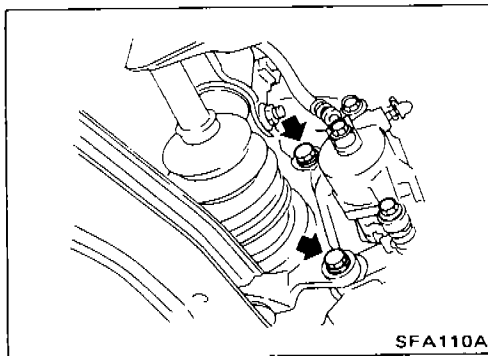

SFA110A

- Remove brake caliper assembly.
Brake hose need not be disconnected from brake caliper.
Be careful not to depress brake pedal, or piston will pop out.
Make sure brake hose is not twisted.

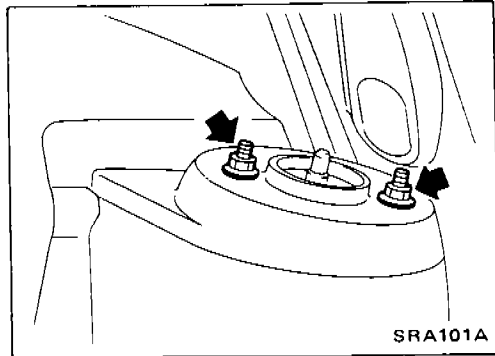

SRA101A

- Remove upper end nuts of shock absorber.
Do not remove piston rod lock nut.
- Remove suspension member fixing nuts. Then draw out rear axle and rear suspension assembly.

REAR AXLE — Wheel Hub and Axle Housing

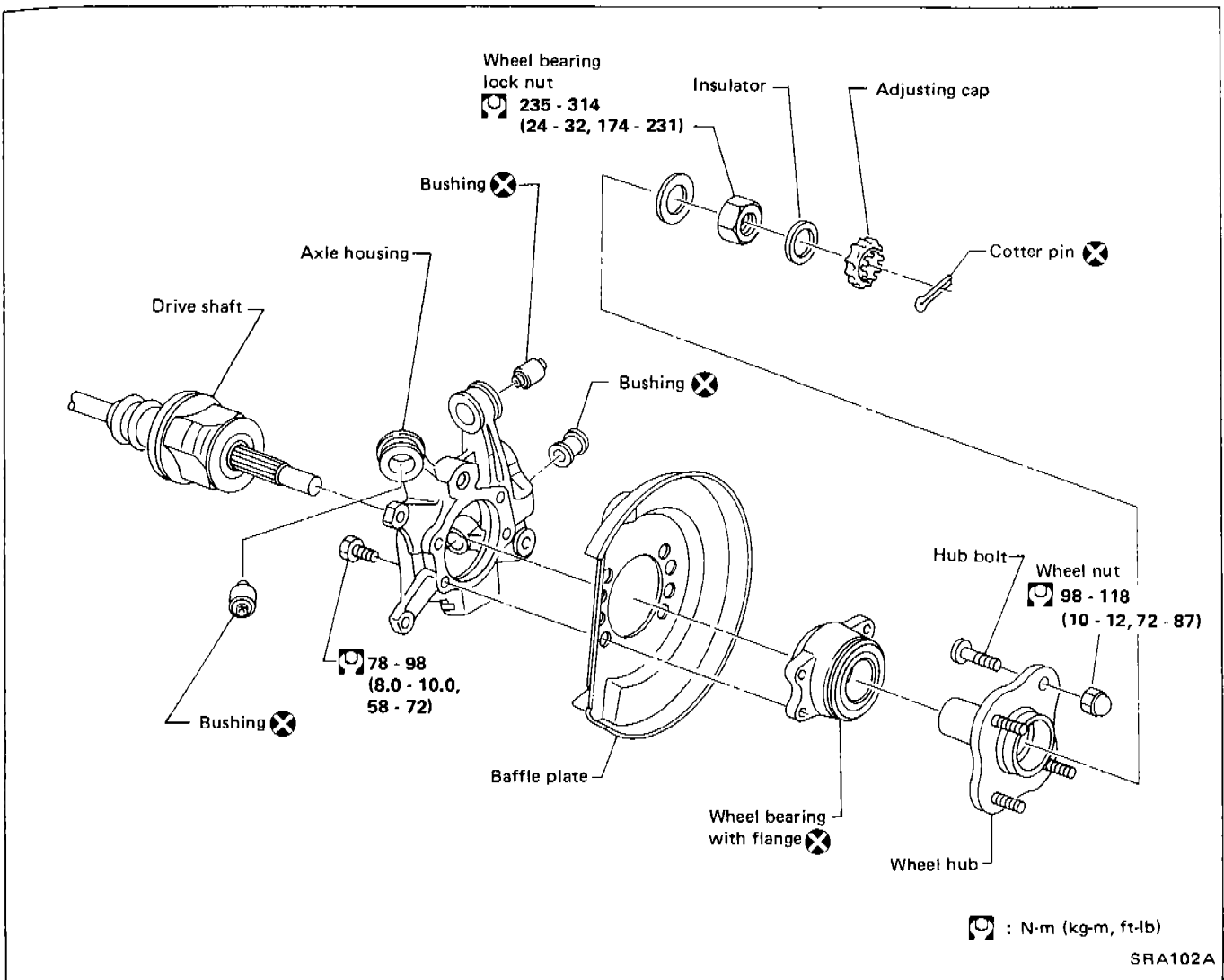

Removal

- Remove wheel bearing lock nut.

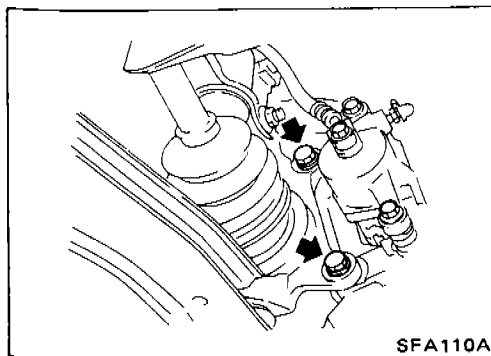

- Remove brake caliper assembly and rotor. Brake hose need not be disconnected from brake caliper. Be careful not to depress brake pedal, or piston will pop out. Make sure brake hose is not twisted.

REAR AXLE — Wheel Hub and Axle Housing

Removal (Cont'd)

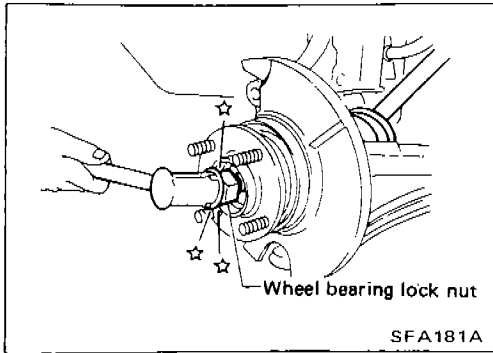

- Separate drive shaft from axle housing by slightly tapping it. When removing drive shaft, cover boots with waste cloth to prevent them from being damaged.

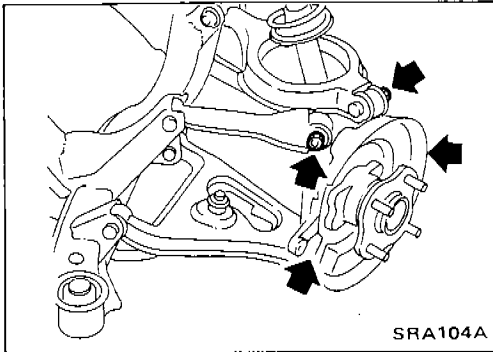

- Remove axle housing.

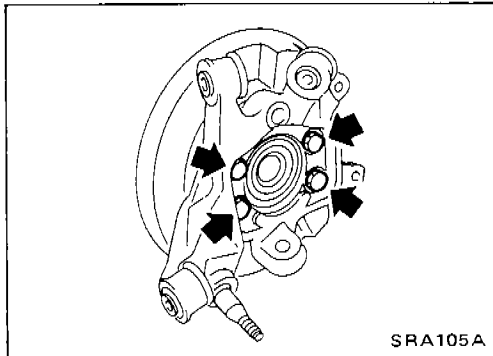

- Remove wheel bearing with flange, and wheel hub from axle housing.

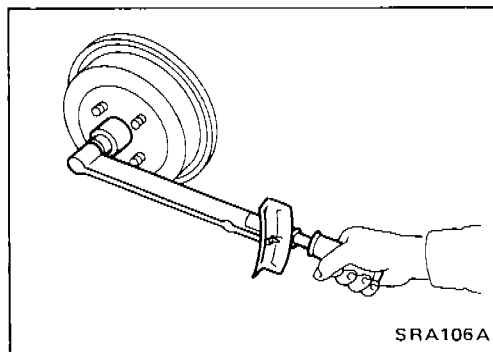

Installation

- Install axle housing with wheel hub.
- Tighten wheel bearing lock nut.
Ⓜ: 235 - 314 N·m
(24 - 32 kg-m, 174 - 231 ft-lb)

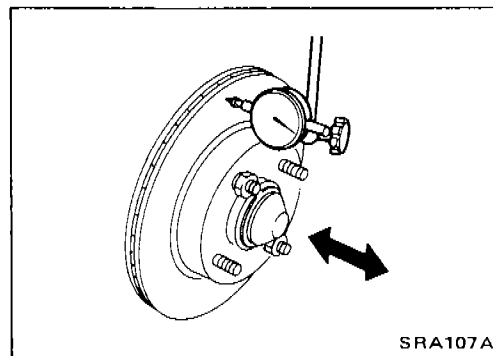

- Check wheel bearing axial end play.
Axial end play: 0.05 mm (0.0020 in) or less

REAR AXLE — Wheel Hub and Axle Housing

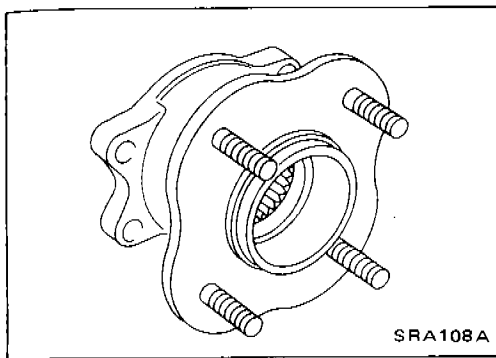

Disassembly

CAUTION:

Wheel bearing with flange usually does not require maintenance. If any of the following symptoms are noted, replace wheel bearing assembly (including flange, and inner and outer seals).

- Growling noise is emitted from wheel bearing during operation.
- Wheel bearing drags or turns roughly when hub is turned with your hand after bearing lock nut is tightened to specified torque.
- After wheel bearing is removed from hub.

WHEEL HUB

- Remove wheel bearing (with flange) and wheel hub as one unit from axle housing before disassembling.

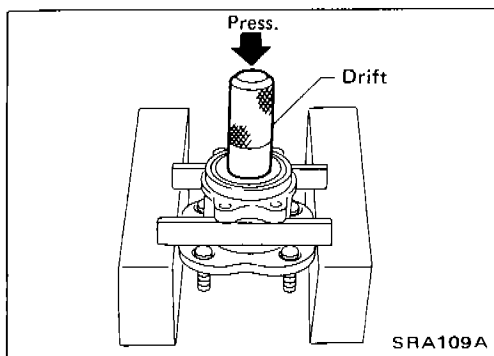

WHEEL BEARING

- Using a press and drift as shown in figure at left, press wheel bearing out.
- Discard old wheel bearing assembly. Replace with a new wheel assembly.

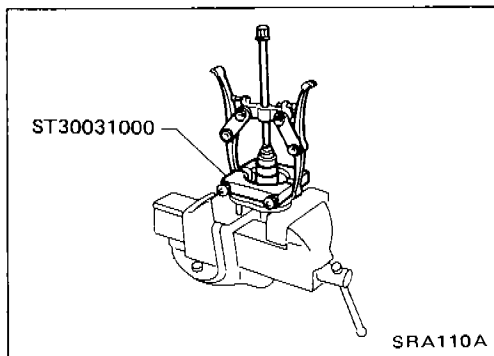

- Remove inner race from hub using a bearing replacer/puller.

CAUTION:

- Do not reuse old inner race although it is of the same brand as the bearing assembly.
- Do not replace grease seals as single parts.

REAR AXLE — Wheel Hub and Axle Housing

Disassembly (Cont'd)

AXLE HOUSING

- Attach a drift on outer shell of bushing as shown in figure at left, remove bushing using arm bushing remover.

When placing axle housing in a vise, use wooden blocks or copper plates as pads.

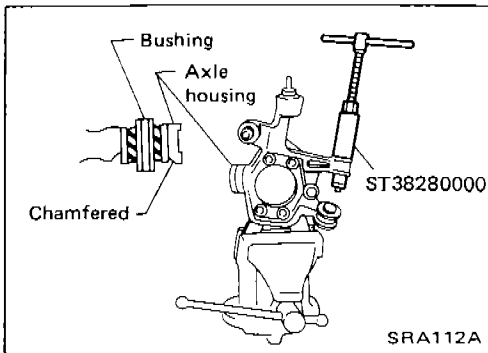
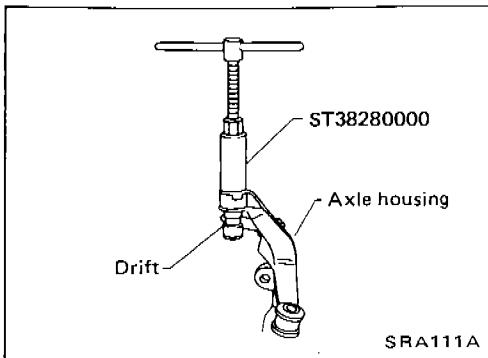

- Ensure axle housing bore is free from scratches or deformities before pressing bushing into it.
- Attach bushing to chamfered bore end of axle housing and press it until it is flush with end face of axle housing.

Inspection

WHEEL HUB AND AXLE HOUSING

- Check wheel hub and axle housing for cracks by using a magnetic exploration or dyeing test.
- Check wheel bearing for damage, seizure, rust or rough operation.
- Check rubber bushing for wear or other damage.

Replace if necessary.

Assembly

- Place hub on a block. Attach a drift to inner race of wheel bearing and press it into hub as shown in figure at left.

Be careful not to damage grease seal.

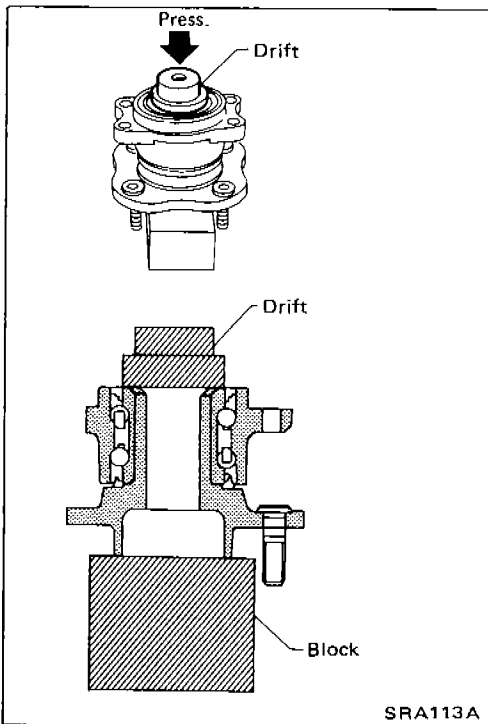

REAR AXLE — Drive Shaft

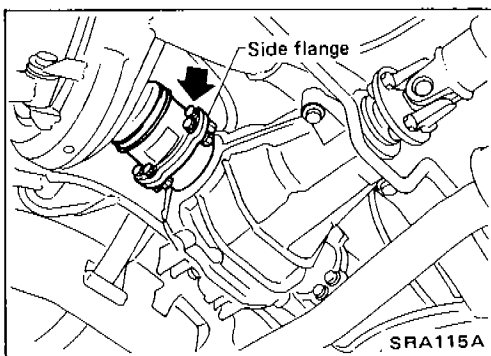
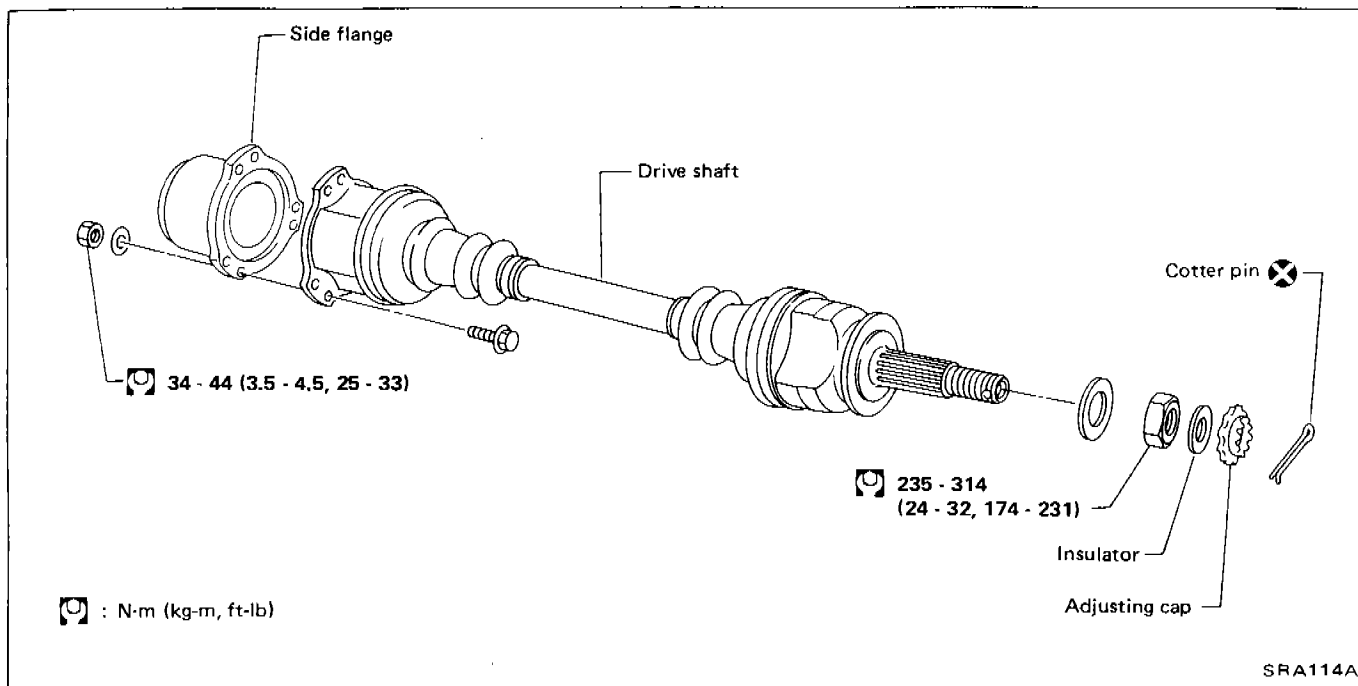

Removal

When removing drive shaft, cover boots with waste cloth to prevent damage to them.

FINAL DRIVE SIDE

- Remove side flange mounting bolt and separate shaft.

WHEEL SIDE

- Remove drive shaft by lightly tapping it with a copper hammer.

To avoid damaging threads of drive shaft, install a nut while removing drive shaft.

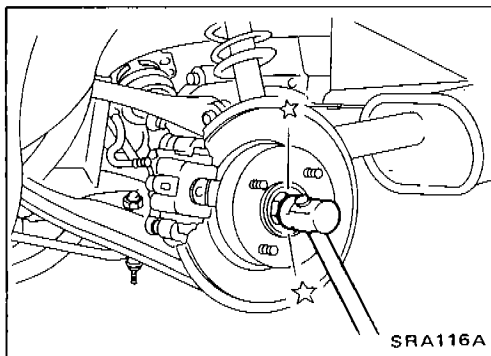

Installation

- Insert drive shaft from wheel hub and temporarily tighten wheel bearing lock nut.
- Tighten side flange mounting bolts to specified torque.
- Tighten wheel bearing lock nut to specified torque.

REAR AXLE — Drive Shaft

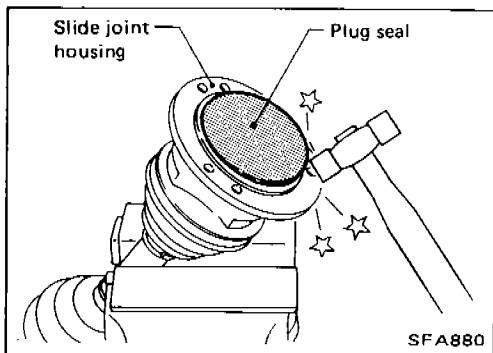
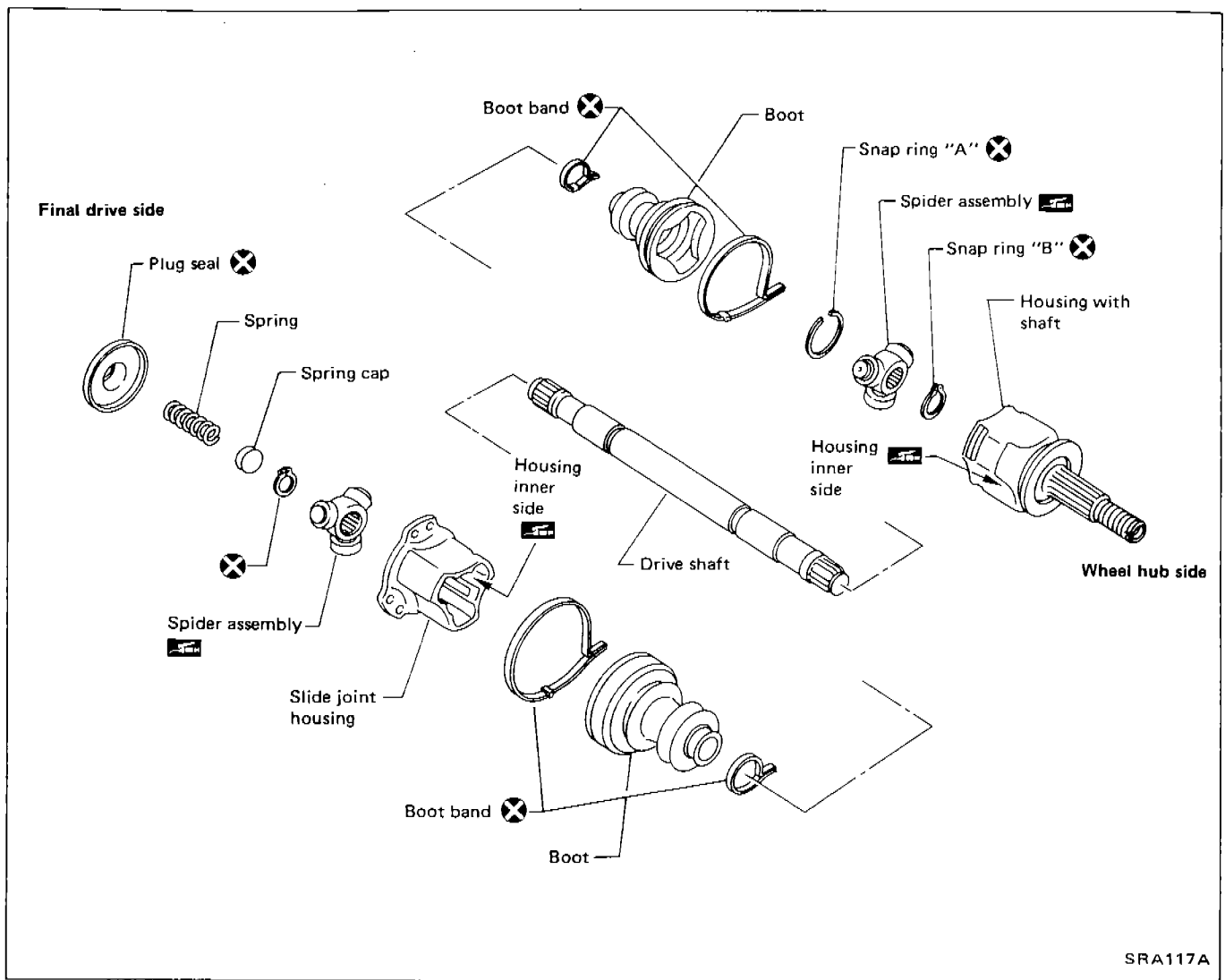

Disassembly

FINAL DRIVE SIDE

1. Remove plug seal from slide joint housing by lightly tapping around slide joint housing.

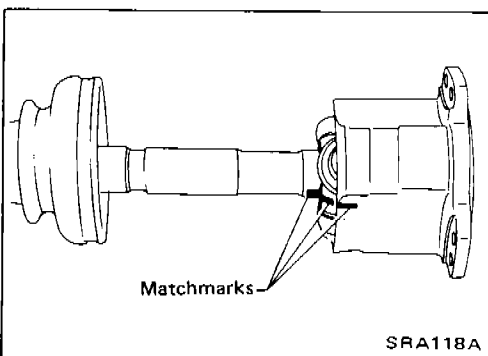

2. Remove boot bands.
3. Put matchmarks on slide joint housing and drive shaft before separating joint assembly.
4. Put matchmarks on spider assembly and drive shaft.

REAR AXLE — Drive Shaft

Disassembly (Cont'd)

5. Pry off snap ring, then remove spider assembly.

CAUTION:

Do not disassemble spider assembly.

6. Draw out slide joint housing.
7. Draw out boot.

Cover drive shaft serration with tape to prevent damage to the boot.

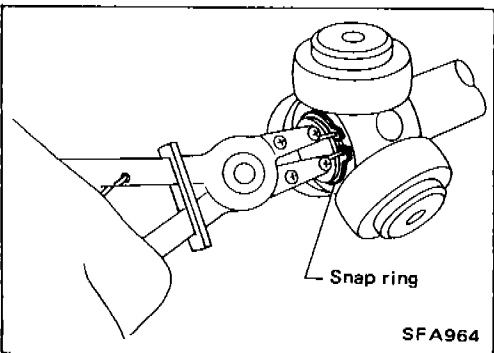
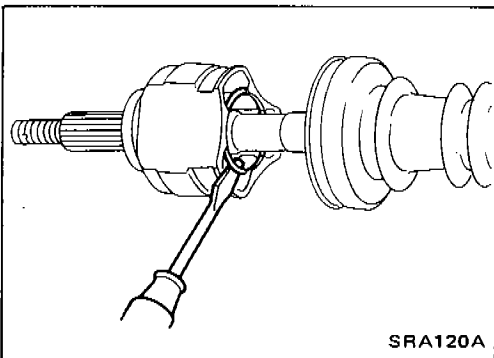
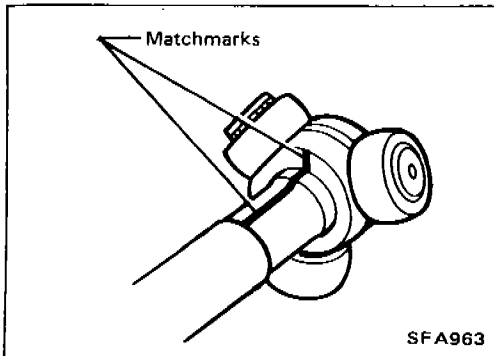
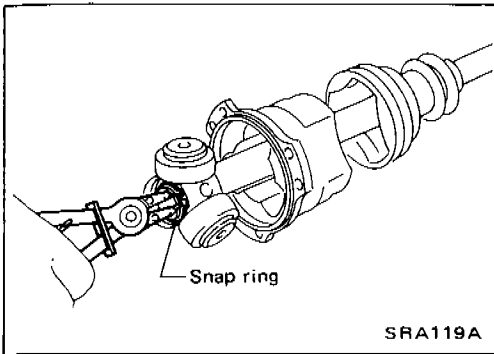

WHEEL SIDE

1. Remove boot bands.
2. Put matchmarks on housing together with shaft and drive shaft before separating joint assembly.
3. Put matchmarks on spider assembly and drive shaft.

4. Pry off snap ring "A" with a screwdriver, and pull out slide joint housing.

5. Pry off snap ring "B", then remove spider assembly.

CAUTION:

Do not disassemble spider assembly.

6. Draw out boot.

Cover drive shaft serration with tape to prevent damage to the boot.

Inspection

Thoroughly clean all parts in cleaning solvent, and dry with compressed air. Check parts for deformation or other damage.

DRIVE SHAFT

Replace drive shaft if it is twisted or cracked.

BOOT

Check boot for fatigue, cracks, or wear. Replace boot with new boot bands.

REAR AXLE — Drive Shaft

Inspection (Cont'd)

JOINT ASSEMBLY

- Check spider assembly for bearing, roller and washer damage. Replace spider assembly if necessary.
- Check housing for any damage. Replace housing set and spider assembly, if necessary.

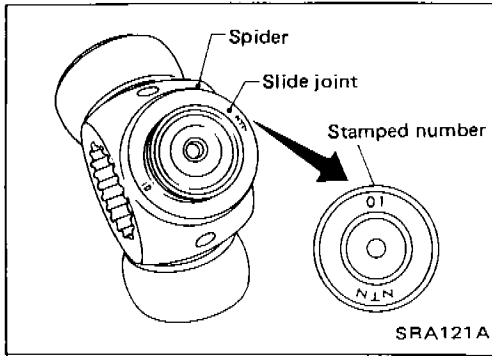

- When replacing only spider assembly, select a new spider assembly from among those listed in table below. Ensure the number stamped on sliding joint is the same as that stamped on new part.

Housing alone cannot be replaced. It must be replaced together with spider assembly.

| Stamped number | Part No. |
|----------------|-------------|
| 00 | 39720 10V10 |
| 01 | 39720 10V11 |
| 02 | 39720 10V12 |

Assembly

- After drive shaft has been assembled, make sure it moves smoothly over its entire range without binding.
- Use Nissan Genuine Grease or equivalent after every overhaul.

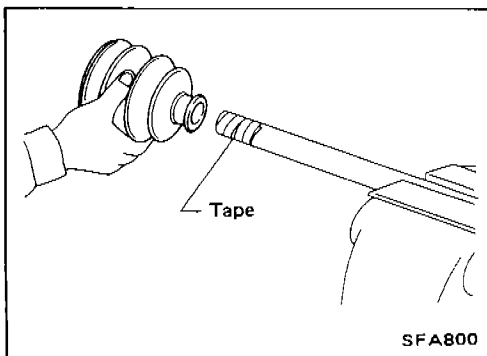

FINAL DRIVE SIDE

1. Install new small boot band, boot and slide joint housing to drive shaft.

Cover drive shaft serration with tape to prevent damage to boot during installation.

REAR AXLE — Drive Shaft

Assembly (Cont'd)

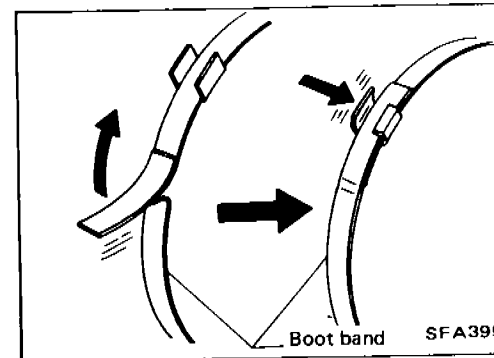
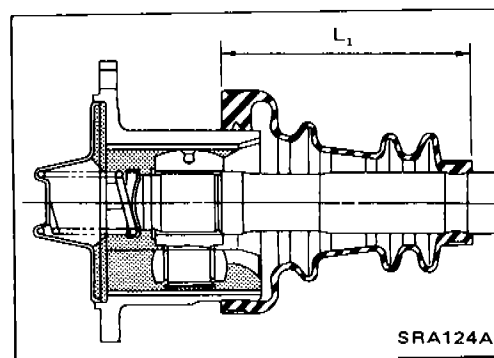
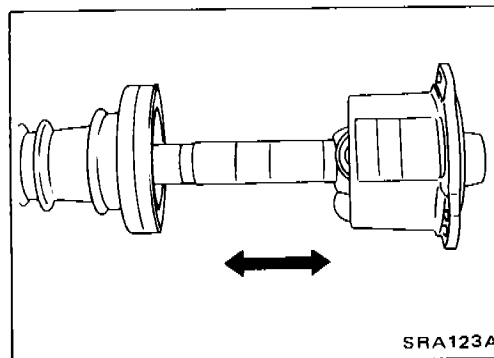
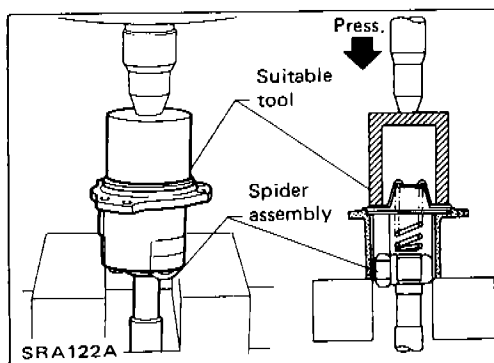
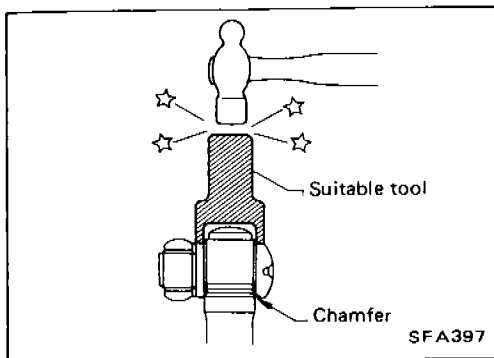

2. Install spider assembly securely, making sure marks are properly aligned.
 - Press-fit with spider assembly serration chamfer facing shaft.
3. Install new snap ring.

4. Install coil spring, spring cap and new plug seal to slide joint housing. Press plug seal.

Apply sealant to mating surface of plug seal.

CAUTION:

- a. When pressing plug seal into place, hold it horizontal so that spring inside it does not tilt or fall down.
- b. Move shaft in axial direction to ensure that spring is installed properly. If shaft drags or if spring is not installed properly, remove plug seal and install a new one. Discard plug seal after removal.

5. Pack drive shaft with specified amount of grease.

Specified amount of grease:

185 - 195 g (6.52 - 6.88 oz)

6. Set boot so that it does not swell and deform when its length is " L_1 ".

Length " L_1 ":

110.5 - 112.5 mm (4.35 - 4.43 in)

Make sure that boot is properly installed on the drive shaft groove.

REAR AXLE — Drive Shaft

Assembly (Cont'd)

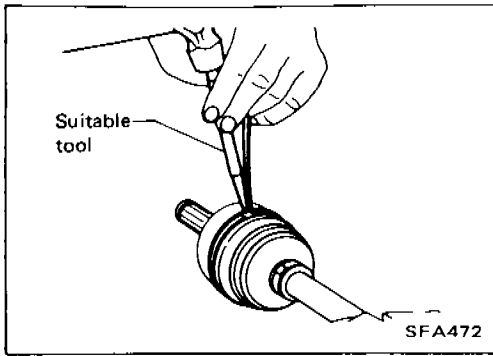

7. Lock new larger boot band securely with a suitable tool, then lock new smaller boot band.

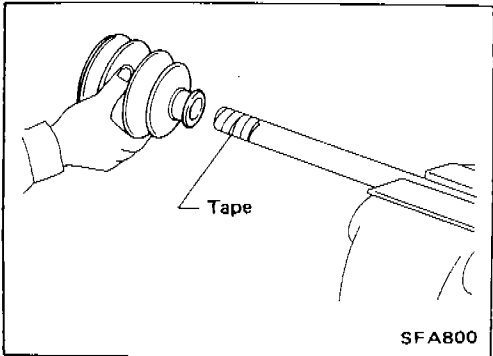

WHEEL SIDE

1. Install new small boot band and boot on drive shaft.
Cover drive shaft serration with tape to prevent damage to boot during installation.

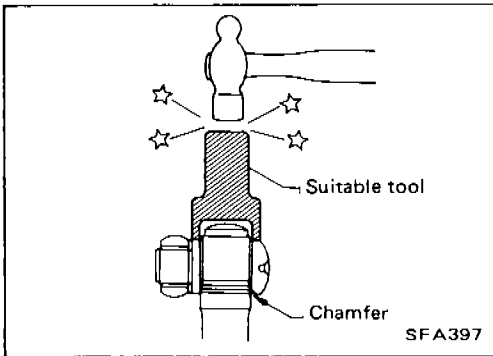

2. Install spider assembly securely, making sure marks are properly aligned.
 - Press-fit with spider assembly serration chamfer facing shaft.
3. Install new snap ring.

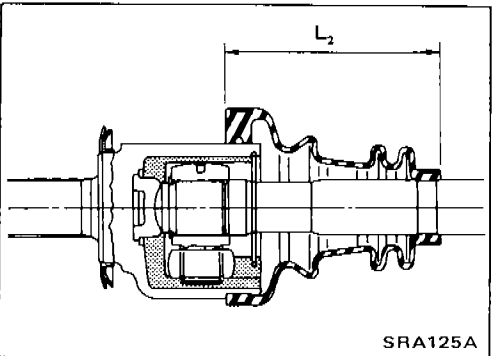

4. Pack drive shaft with specified amount of grease.

Specified amount of grease:

145 - 155 g (5.11 - 5.47 oz)

5. Install slide joint housing, then install new snap ring "A".
6. Set boot so that it does not swell and deform when its length is " L_2 ".

Length " L_2 ":

110.5 - 112.5 mm (4.35 - 4.43 in)

Make sure that boot is properly installed on the drive shaft groove.

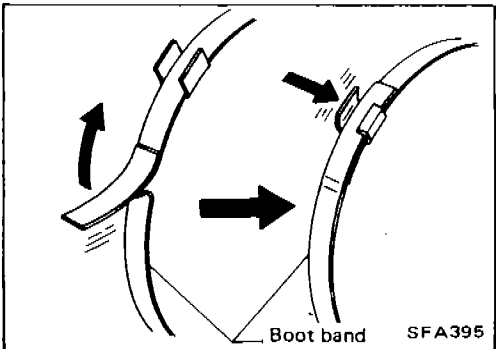

7. Lock new larger and smaller boot bands securely with a suitable tool.

Removal

- Remove shock absorber upper and lower fixing nuts.
- Do not remove piston rod lock nut on vehicle.

Disassembly

1. Set shock absorber on vise with attachment, then loosen piston rod lock nut.

- Do not remove piston rod lock nut.

2. Compress spring with Tool so that the strut upper spring seat can be turned by hand.

3. Remove piston rod lock nut.

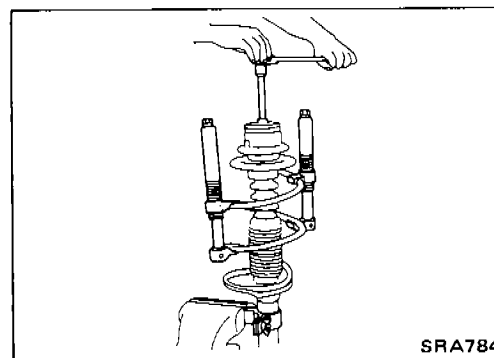
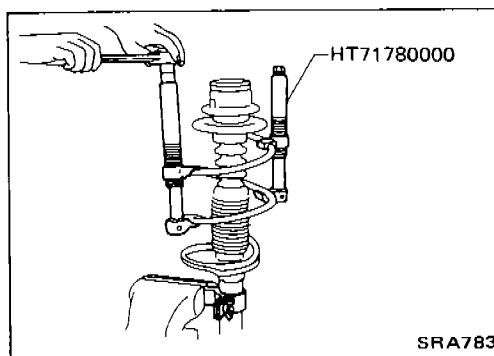
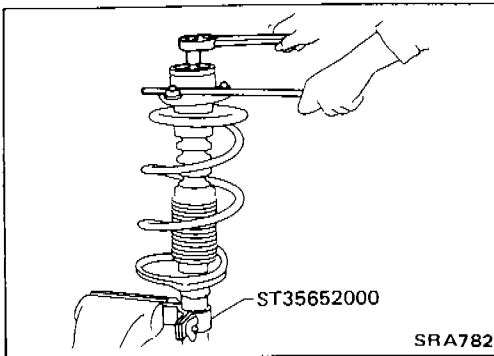

Inspection

SHOCK ABSORBER ASSEMBLY

- Check for smooth operation through a full stroke, both compression and extension.
- Check for oil leakage occurring on welded or gland packing portion.
- Check piston rod for cracks, deformation or other damage. Replace if necessary.

UPPER RUBBER SEAT AND BUSHING

- Check rubber parts for deterioration or cracks. Replace if necessary.

REAR SUSPENSION — Coil Spring and Shock Absorber

Inspection (Cont'd)

COIL SPRING

- Check for cracks, deformation or other damage. Replace if necessary.

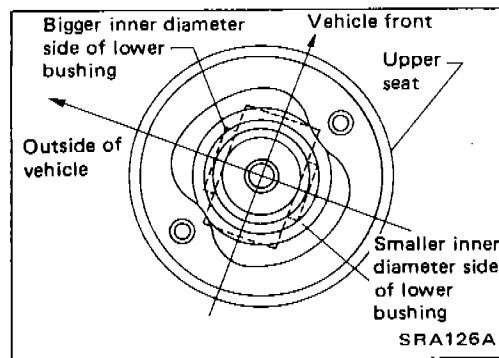
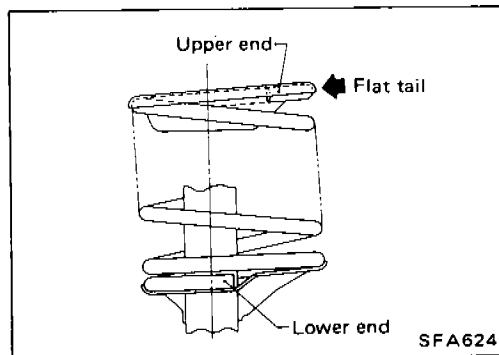
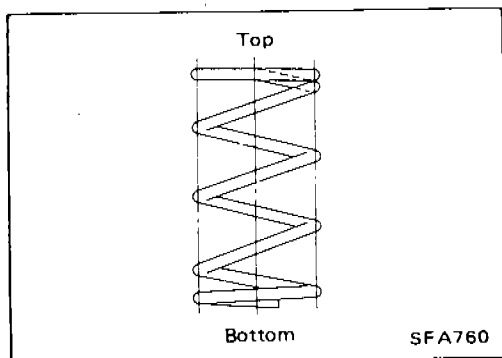

Assembly

- When installing coil spring, be careful not to reverse top and bottom direction. (Top end is flat.)
- When installing coil spring on strut, it must be positioned as shown in figure at left.
- When installing upper spring seat, make sure that it is positioned as shown.

REAR SUSPENSION — Stabilizer Bar

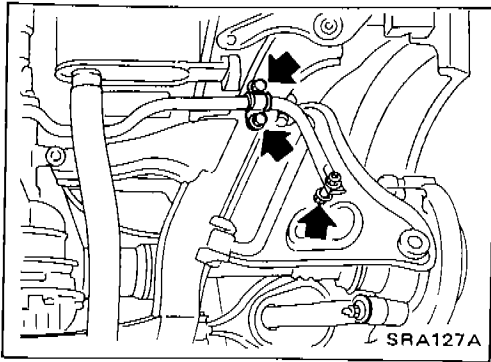

Removal

- Remove connecting rod and clamp.

Inspection

- Check stabilizer bar for deformation or cracks. Replace if necessary.
- Check rubber bushings for deterioration or cracks. Replace if necessary.

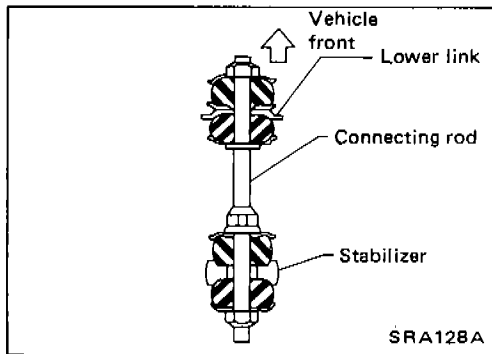

Installation

- When installing connecting rod, make sure direction is correct (as shown at left).

Removal and Installation

- Refer to "Removal and Installation" of REAR AXLE AND REAR SUSPENSION ASSEMBLY.

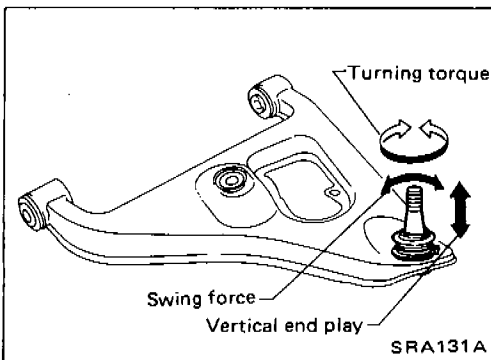
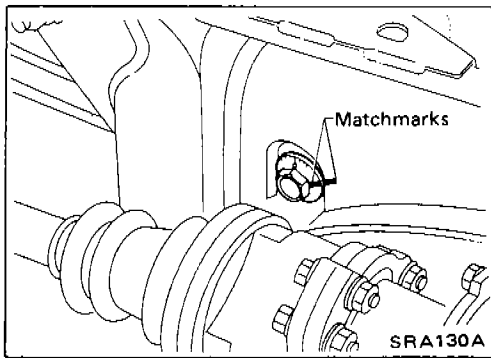
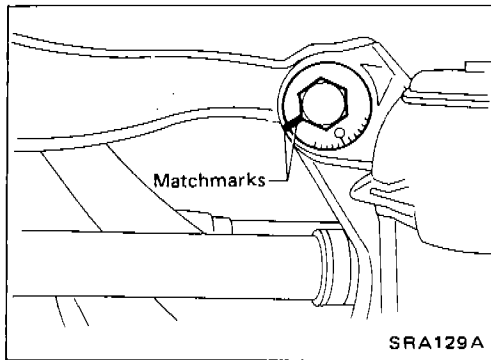

Before removing, put matchmarks on adjusting pin.

- When installing, final tightening must be carried out at curb weight with tires on ground.
- After installation, check wheel alignment. Refer to "Rear Wheel Alignment" of CHECK AND ADJUSTMENT — On vehicle.

Inspection

REAR SUSPENSION MEMBER

- Replace suspension member assembly if cracked or deformed or if any part (insulator, for example) is damaged.

UPPER AND LOWER LINKS

- Replace upper or lower link as required if cracked or deformed or if bushing is damaged.

SUSPENSION LOWER BALL JOINT

- Measure swing force, turning torque and vertical end play in axial direction. (Use same measurement procedures as that of FA section.)
- If ball stud is worn, play in axial direction is excessive, or joint is hard to swing, replace lower arm.

| | | |
|---------------------------|-------------------|---------------------------------------------------|
| Ball joint specifications | Swing force | 12.7 - 90.2 N (1.3 - 9.2 kg, 2.9 - 20.3 lb) |
| | Turning torque | 0.5 - 3.4 N·m (5 - 35 kg·cm, 4.3 - 30.4 in·lb) |
| | Vertical end play | 0 mm (0 in) |

SERVICE DATA AND SPECIFICATIONS (S.D.S.)

Inspection and Adjustment

WHEEL ALIGNMENT (Unladen*)

| | | |
|--------|----------------|--------------------|
| Camber | degree | -1° 40' to -0° 40' |
| Toe-in | mm (in) | 0 - 5 (0 - 0.20) |
| | (Total) degree | 0' - 28' |

* Tankful of fuel, radiator coolant and engine oil full.
Spare tire, jack, hand tools, mats in designated position.

WHEEL RUNOUT (Radial and lateral)

| Wheel type | Radial runout | Lateral runout |
|----------------|-------------------------------|---------------------|
| Aluminum wheel | . mm (in) 0.3 (0.012) or less | |
| Steel wheel | 0.5 (0.020) or less | 0.8 (0.031) or less |

WHEEL BEARING

| | | |
|---------------------------------------------|-------------------|--------------------------------|
| Wheel bearing axial end play | mm (in) | 0.05 (0.0020) or less |
| Wheel bearing lock nut Tightening torque | N·m (kg-m, ft-lb) | 235 - 314 (24 - 32, 174 - 231) |

LOWER BALL JOINT

| | | |
|-------------------------------------------------------------------|--------------------|----------------------------------------|
| Swing force (Measuring point: cotter pin hole of ball stud) | N (kg, lb) | 12.7 - 90.2 (1.3 - 9.2, 2.9 - 20.3) |
| Turning torque | N·m (kg-cm, in-lb) | 0.5 - 3.4 (5 - 35, 4.3 - 30.4) |
| Vertical end play | mm (in) | 0 (0) |

SERVICE DATA AND SPECIFICATIONS (S.D.S.)

General Specifications

COIL SPRING

| | | |
|----------------------|---------------------|------------------------|
| Wire diameter | mm (in) | 11.0 (0.433) |
| Coil diameter | mm (in) | 90 - 100 (3.54 - 3.94) |
| Free length | mm (in) | 367.5 (14.47) |
| Spring constant | N/mm (kg/mm, lb/in) | 19.6 (2.0, 112) |
| Identification color | | Pink x 2 |

SHOCK ABSORBER

| Item | Model | Europe | Except Europe |
|-------------------------------------------|------------|---------------------|---------------|
| | | Piston rod diameter | mm (in) |
| Stroke | mm (in) | 155 (6.10) | |
| Damping force [at 0.3 m (1.0 ft)/sec.] | N (kg, lb) | | |
| Expansion | | 902 (92, 203) | 696 (71, 157) |
| Compression | | 539 (55, 121) | 333 (34, 75) |

DRIVE SHAFT

| | | |
|----------------------------|---------|-------------------------------------|
| Joint type | | TS82F |
| Final drive side | | |
| Wheel side | | TS82C |
| Diameter | mm (in) | |
| Wheel side D_1 | | 30 (1.18) |
| Grease name | | Nissan genuine grease or equivalent |
| Specified amount of grease | g (oz) | |
| Final drive side | | 185 - 195 (6.52 - 6.88) |
| Wheel side | | 145 - 155 (5.11 - 5.47) |
| Boot length | mm (in) | |
| Final drive side (L_1) | | 110.5 - 112.5 (4.35 - 4.43) |
| Wheel side (L_2) | | |

Final drive side

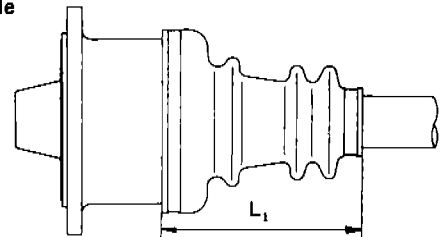

SRA133A

Wheel side

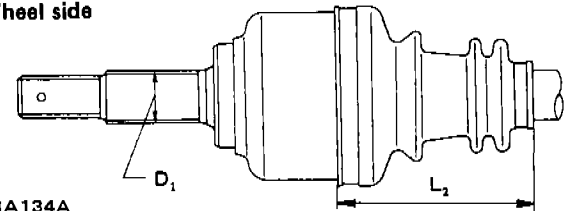

SRA134A

REAR STABILIZER BAR

| | | |
|----------------------|---------|-----------|
| Stabilizer diameter | mm (in) | 16 (0.63) |
| Identification color | | Pink |

BRAKE SYSTEM

SECTION **BR**

CONTENTS

| | |
|---------------------------------------------------------------|-------|
| PRECAUTIONS AND PREPARATION | BR- 2 |
| CHECK AND ADJUSTMENT | BR- 3 |
| BRAKE HYDRAULIC LINE | BR- 4 |
| BRAKE PEDAL AND BRACKET | BR- 6 |
| BRAKE BOOSTER | BR- 8 |
| VACUUM PIPING | BR-10 |
| MASTER CYLINDER | BR-12 |
| FRONT DISC BRAKE (CL18VB, CL25VA) — Caliper | BR-13 |
| FRONT DISC BRAKE (CL18VB, CL25VA) — Rotor | BR-17 |
| REAR DISC BRAKE (CL9H) — Caliper | BR-18 |
| REAR DISC BRAKE (CL9H) — Rotor | BR-22 |
| REAR DISC BRAKE (AD9) — Caliper | BR-23 |
| REAR DISC BRAKE (AD9) — Rotor | BR-27 |
| PARKING BRAKE CONTROL | BR-28 |
| PARKING DRUM BRAKE (DS17HD) — Rear Disc Brake AD9 Model | BR-30 |
| ANTI-LOCK BRAKING SYSTEM | BR-32 |
| TROUBLE DIAGNOSES | BR-37 |
| SERVICE DATA AND SPECIFICATIONS (S.D.S.) | BR-62 |

BR

PRECAUTIONS AND PREPARATION

Precautions

- Recommended fluid is brake fluid "DOT 3".
- Never reuse drained brake fluid.
- Be careful not to splash brake fluid on painted areas.
- To clean or wash all parts of master cylinder, disc brake caliper and wheel cylinder, use clean brake fluid.
- Never use mineral oils such as gasoline or kerosene. They will ruin rubber parts of hydraulic system.

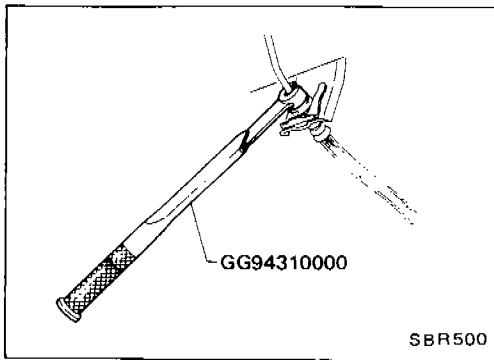

- Use Tool when removing and installing brake tube.

WARNING:

- Clean brake pads and shoes with a waste cloth, then collect dust with a dust collector.

Preparation

SPECIAL SERVICE TOOL

*: Special tool or commercial equivalent

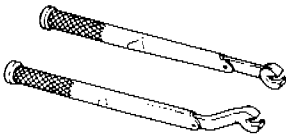
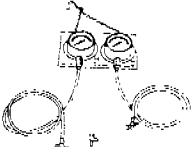
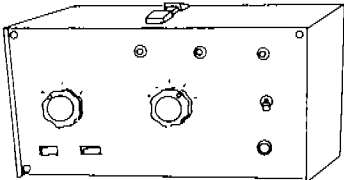
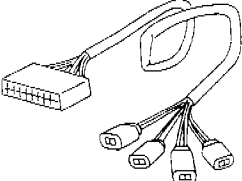
| Tool number Tool name | Description |
|----------------------------------------------|---------------------------------------------------------------------------------------------------------------------------------------------|
| GG94310000* Flare nut torque wrench |  <p>Removing and installing each brake piping</p> |
| KV991V0010* Brake fluid pressure gauge |  <p>Measuring brake fluid pressure</p> |
| KV999P1000 A.B.S. checker |  <p>Checking brake fluid pressure of A.B.S. actuator</p> |
| KV999P1010 A.B.S. checker adapter harness |  <p>Checking brake fluid pressure of A.B.S. actuator</p> |

CHECK AND ADJUSTMENT

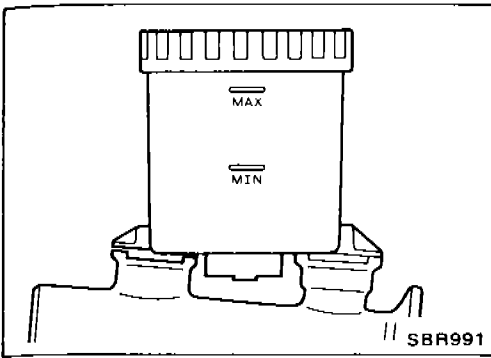

Checking Brake Fluid Level

- Check fluid level in reservoir tank. It should be between Max. and Min. lines on reservoir tank.
- If fluid level is extremely low, check brake system for leaks.

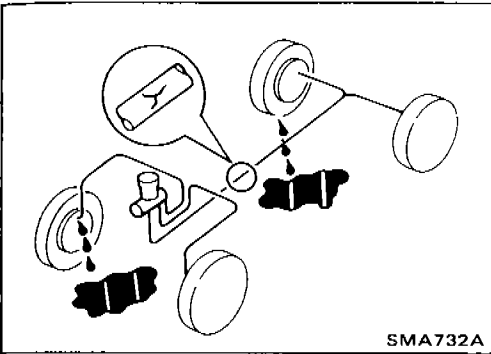

Checking Brake System

- Check brake lines (tubes and hoses) for cracks, deterioration or other damage. Replace any damaged parts. If leakage occurs around joints, retighten or, if necessary, replace damaged parts.
- Check for oil leakage by fully depressing brake pedal.

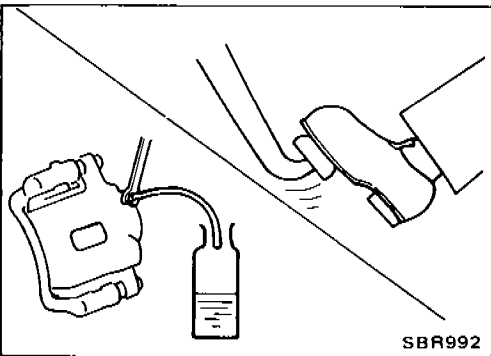

Changing Brake Fluid

1. Drain brake fluid in each air bleeder valve.
2. Refill until new brake fluid comes out of each air bleeder valve.

Use same procedure as in bleeding hydraulic system to refill brake fluid.

Refer to Bleeding Procedure.

- Refill with recommended brake fluid "DOT 3".
- Never reuse drained brake fluid.
- Be careful not to splash brake fluid on painted areas.

BRAKE HYDRAULIC LINE

Without Anti-lock Braking System (A.B.S.)

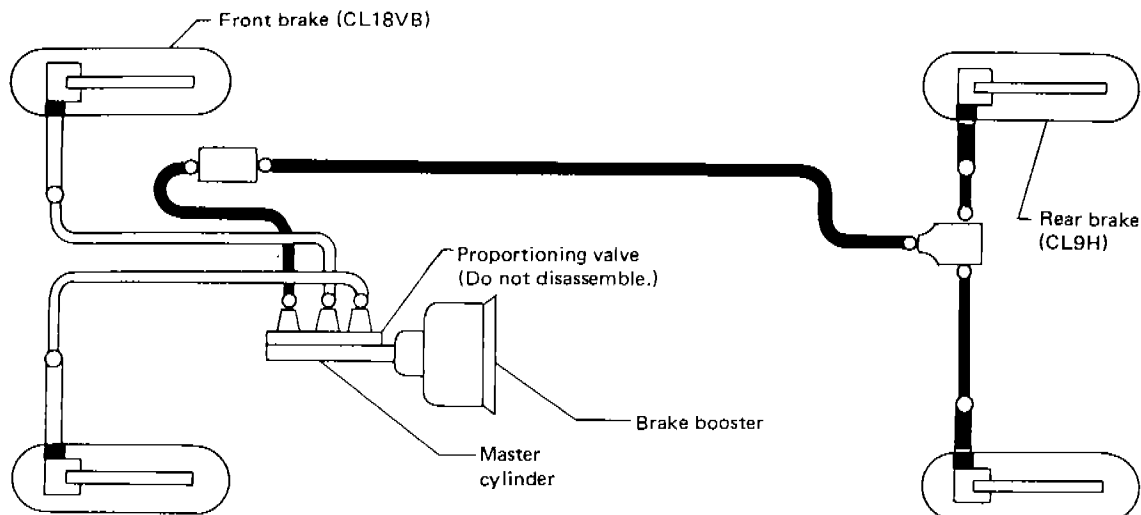

With Anti-lock Braking System (A.B.S.)

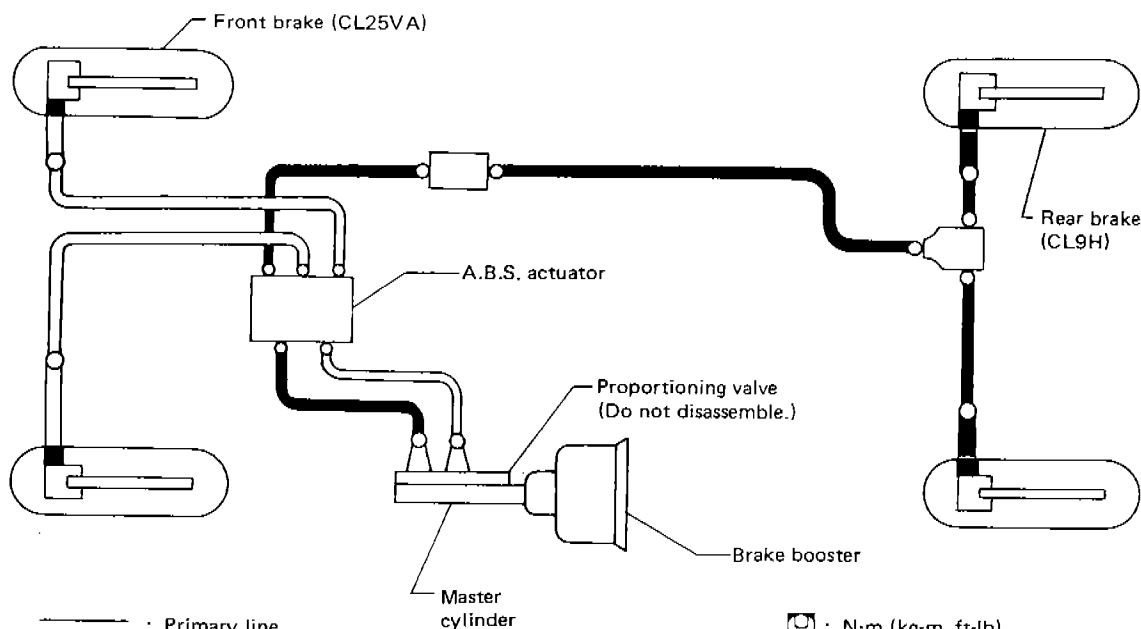

==== : Primary line
 ——— : Secondary line

⊕ : N·m (kg·m, ft·lb)

○ : Flare nut
 15 - 18 (1.5 - 1.8, 11 - 13)
 ■ : Connecting bolt
 17 - 20 (1.7 - 2.0, 12 - 14)

SBR501A

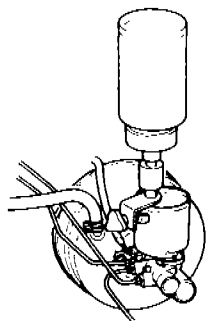

SBR995

Bleeding Procedure

CAUTION:

- Carefully monitor brake fluid level at master cylinder during bleeding operation.
- Fill reservoir with recommended brake fluid. Make sure it is full at all times while bleeding air out of system.
- Place a container beneath master cylinder to avoid spillage of brake fluid.

BRAKE HYDLAULIC LINE

Bleeding Procedure (Cont'd)

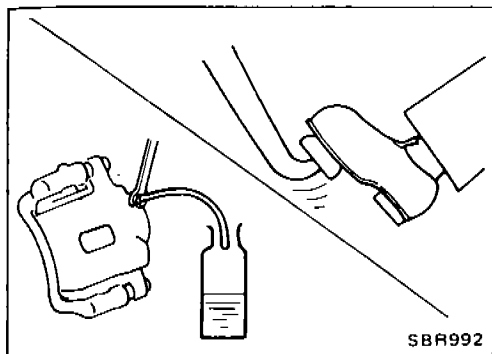

- Bleed air according to the following procedure.

Without Anti-lock Braking System:

Left rear caliper
↓
Right rear caliper
↓
Left front caliper
↓
Right front caliper

With Anti-lock Braking System:

Left rear caliper
↓
Right rear caliper
↓
Left front caliper
↓
Right front caliper
↓
Front side air bleeder on A.B.S. actuator
↓
Rear side air bleeder on A.B.S. actuator

- To bleed air out of lines, wheel cylinders and calipers, use the following procedure.

- 1) Connect a transparent vinyl tube to air bleeder valve.
- 2) Fully depress brake pedal several times.
- 3) With brake pedal depressed, open air bleeder valve to release air.
- 4) Close air bleeder valve.
- 5) Release brake pedal slowly.
- 6) Repeat steps 2) through 5) until clear brake fluid comes out of air bleeder valve.

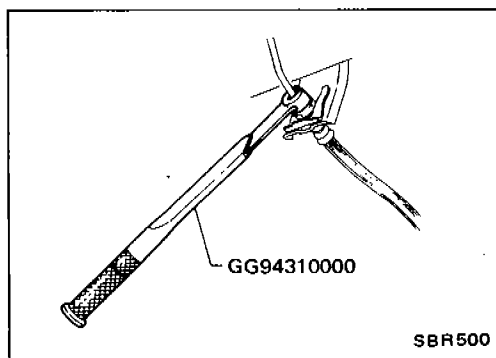

Removal and Installation

1. To remove brake hose, first remove flare nut securing brake tube to hose, then withdraw lock spring.
2. Cover openings to prevent entrance of dirt whenever disconnecting hydraulic line.
3. All hoses must be free from excessive bending, twisting and pulling.
4. After installing brake lines, check for oil leakage by fully depressing brake pedal.

Inspection

Check brake lines (tubes and hoses) for cracks, deterioration or other damage. Replace any damaged parts.

If leakage occurs around joints, retighten or, if necessary, replace damaged parts.

BRAKE PEDAL AND BRACKET

Removal and Installation

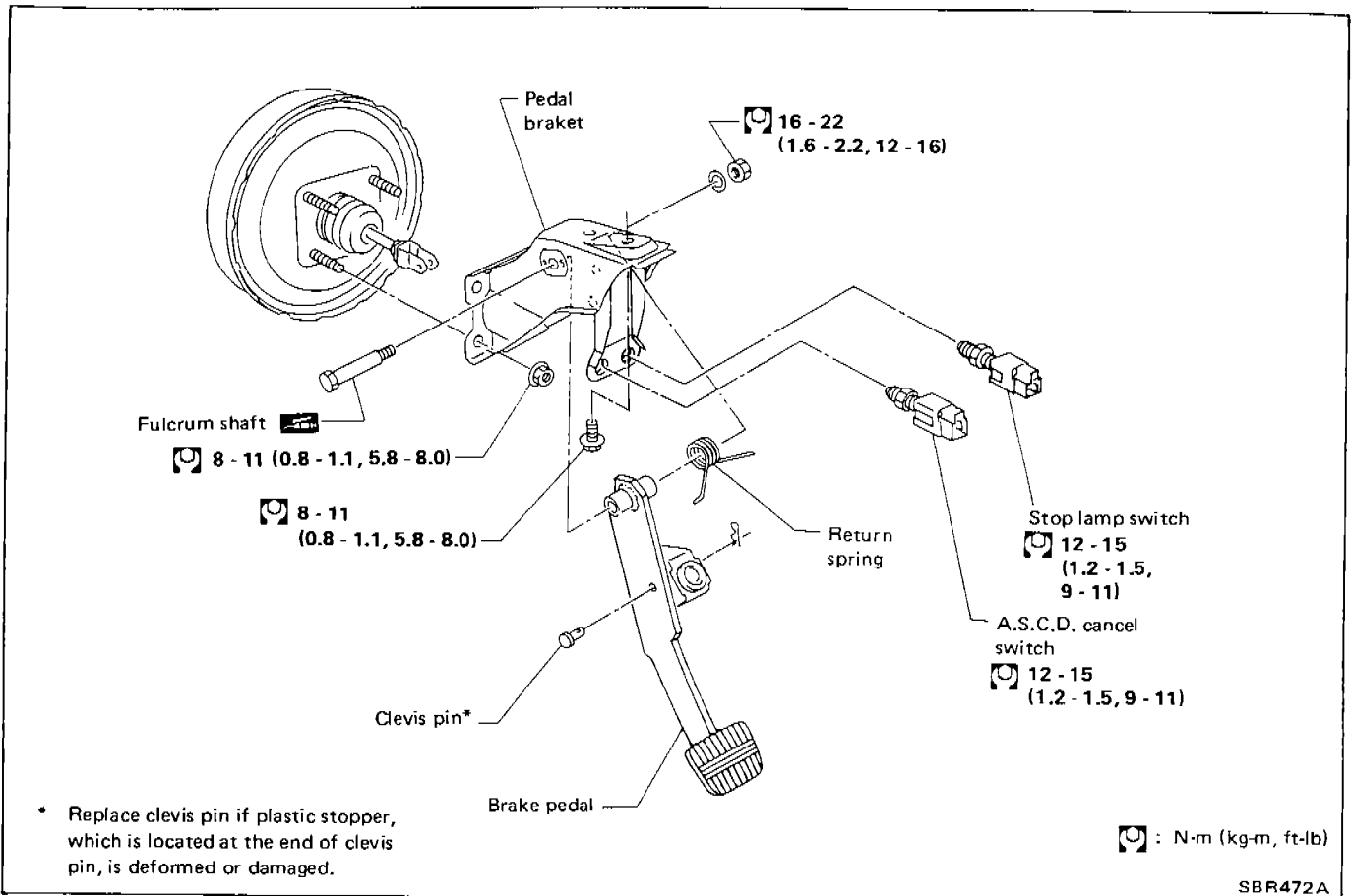

Inspection

Check brake pedal for following items.

- Brake pedal bend
- Clevis pin deformation
- Crack of any welded portion

BRAKE PEDAL AND BRACKET

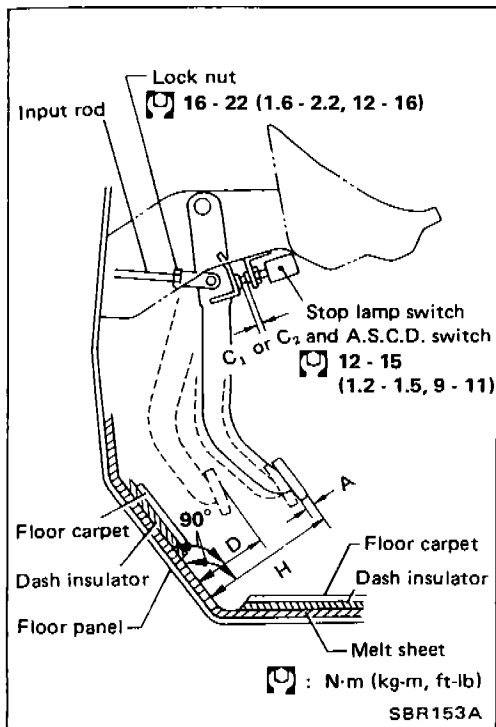

Adjustment

Check brake pedal free height from dash reinforcement panel. Adjust if necessary.

- H: Free height
Refer to S.D.S.
- D: Depressed height
Refer to S.D.S.
Under force of 490 N (50 kg, 110 lb)
with engine running
- C₁: Clearance between pedal stopper and threaded end of stop lamp switch
0.3 - 1.0 mm (0.012 - 0.039 in)
- C₂: Clearance between pedal stopper and threaded end of A.S.C.D. switch
0.3 - 1.0 mm (0.012 - 0.039 in)
- A: Pedal free play
1 - 3 mm (0.04 - 0.12 in)

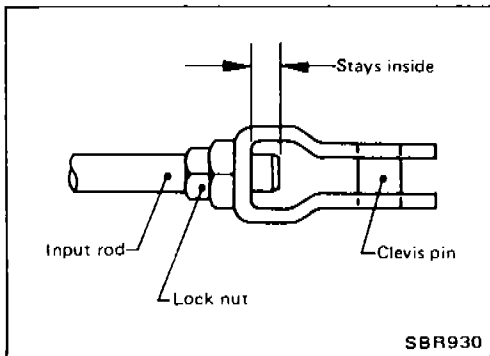

1. Adjust pedal free height with brake booster input rod. Then tighten lock nut.

Make sure that tip of input rod stays inside.

2. Adjust clearance "C₁" and "C₂" with stop lamp switch and A.S.C.D. switch respectively. Then tighten lock nuts.
3. Check pedal free play.
4. Check brake pedal's depressed height while engine is running.

Make sure that stop lamp is off when pedal is released.

If depressed height is below specified value, check brake system for leaks, accumulation of air or any damage to components (master cylinder, wheel cylinder, etc.); then make necessary repairs.

BRAKE BOOSTER

Removal and Installation

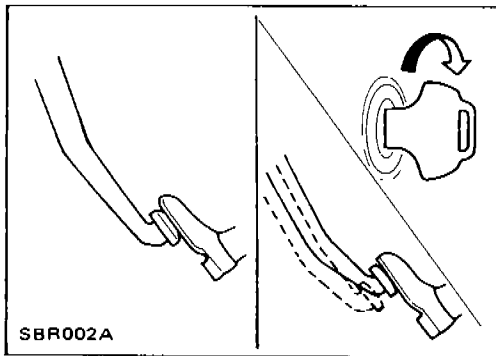
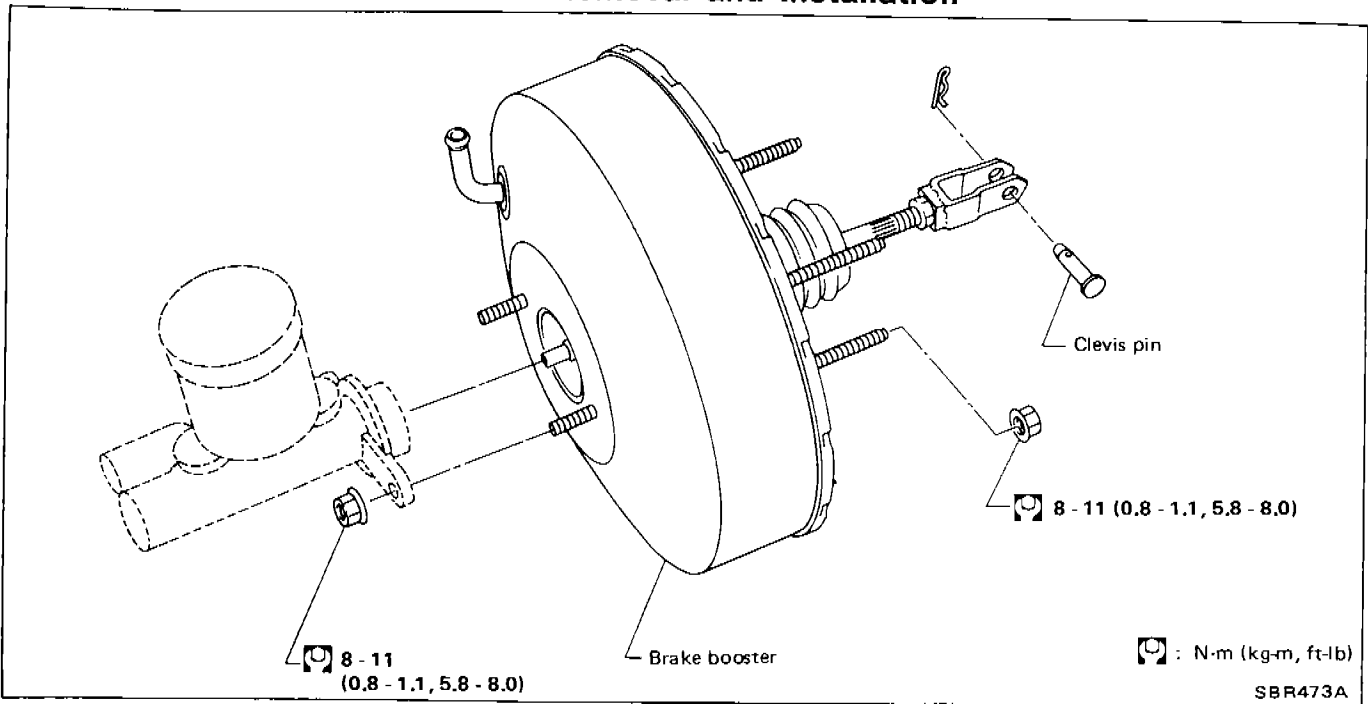

Inspection

OPERATING CHECK

- Depress brake pedal several times with engine off, and check that there is no change in pedal stroke.
- Depress brake pedal, then start engine. If pedal goes down slightly, operation is normal.

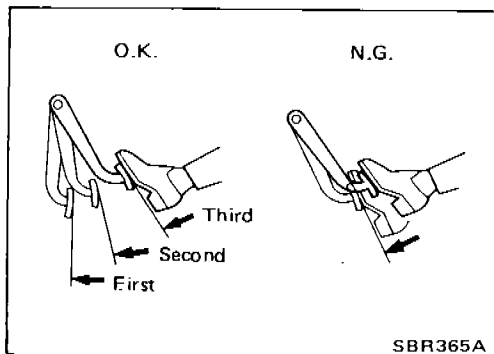

AIRTIGHT CHECK

- Start engine, and stop it after one or two minutes. Depress brake pedal several times slowly. If pedal goes further down the first time and gradually rises after second or third time, booster is airtight.
- Depress brake pedal while engine is running, and stop engine with pedal depressed. If there is no change in pedal stroke after holding pedal down **30 seconds**, brake booster is airtight.

OUTPUT ROD LENGTH CHECK

1. Supply brake booster with vacuum of -66.7 kPa (-667 mbar, -500 mmHg, -19.69 inHg) using a handy vacuum pump.
2. Check output rod length.

Specified length:

10.275 - 10.525 mm (0.4045 - 0.4144 in)

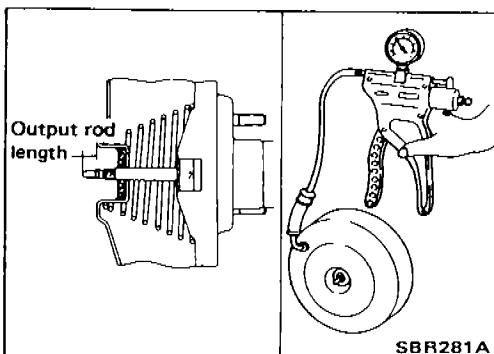

BRAKE BOOSTER

Inspection (Cont'd)

3. Adjust rod length if necessary.
4. If rod length is without specification, replace brake booster.

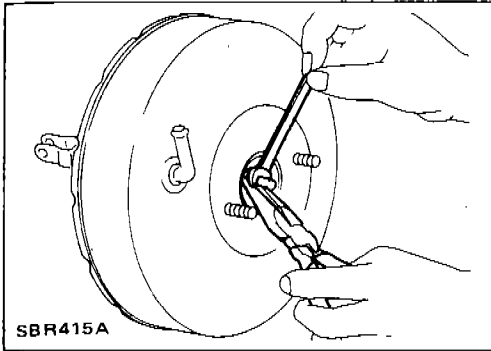

VACUUM PIPING

Removal and Installation

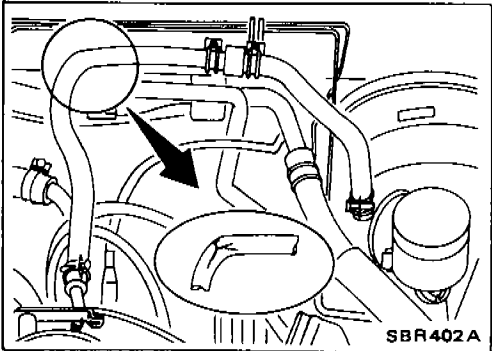
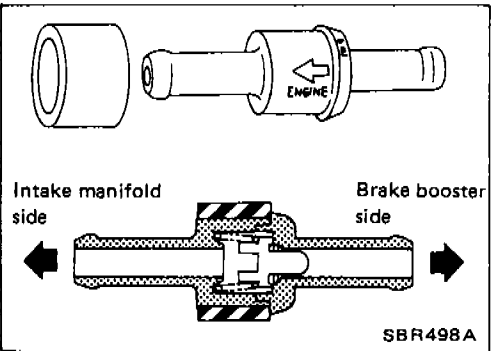
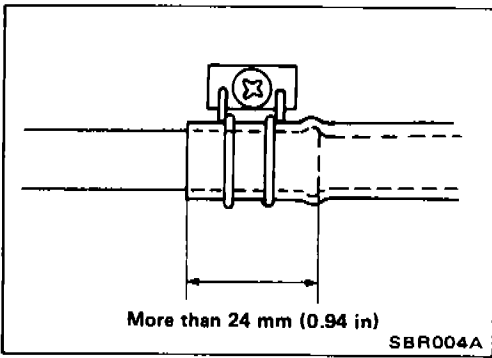
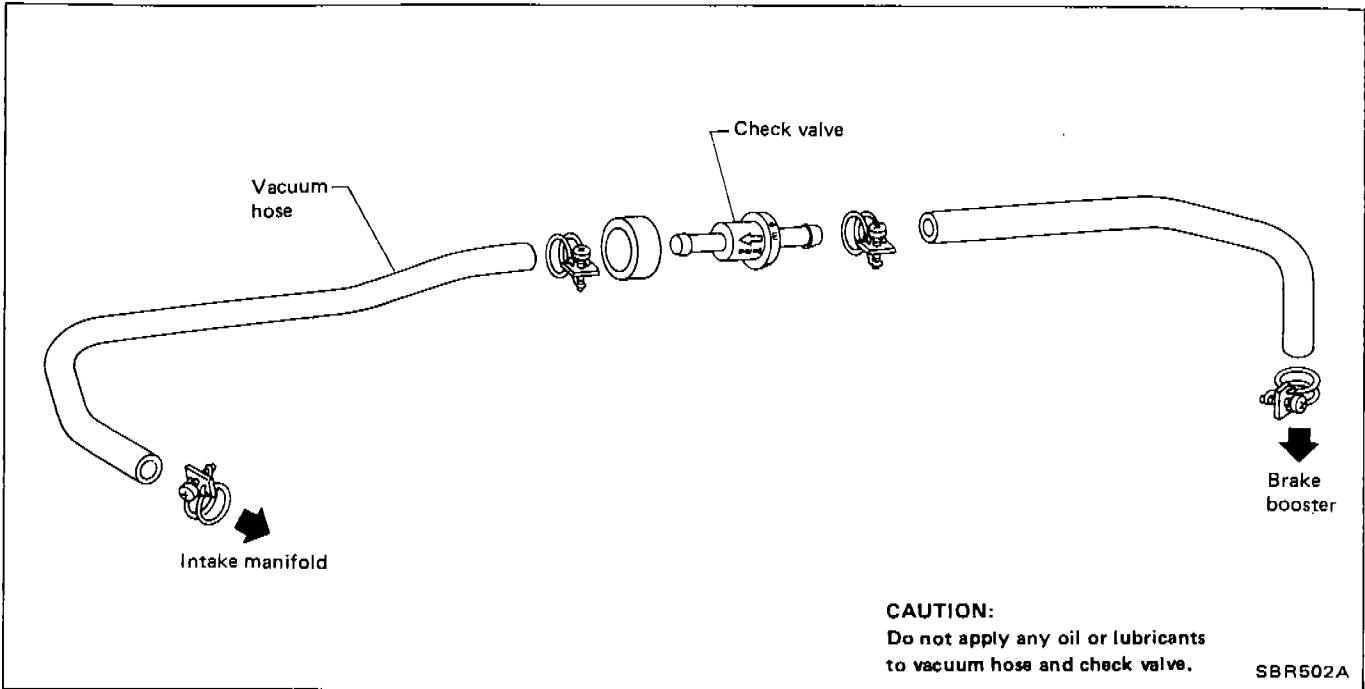

- Insert vacuum tube into vacuum hose more than 24 mm (0.94 in).

- Install check valve, paying attention to its direction.

Inspection

HOSES AND CONNECTORS

- Check vacuum lines, connections and check valve for airtightness, improper attachment chafing and deterioration.

VACUUM PIPING

Inspection (Cont'd)

CHECK VALVE

- When pressure is applied to brake booster side of check valve and valve does not open, replace check valve with a new one.

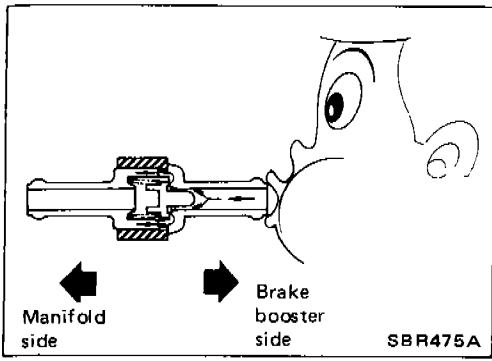

MASTER CYLINDER

Removal and Installation

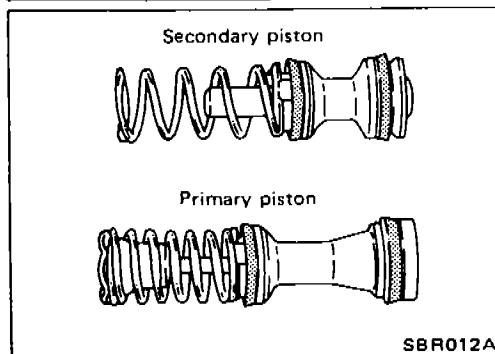
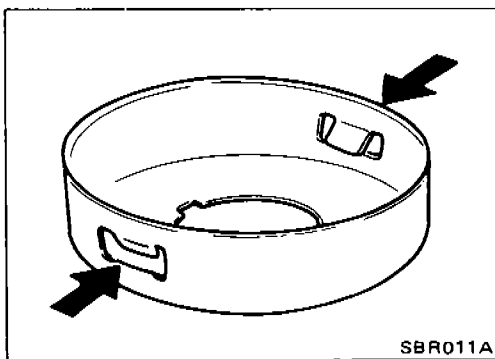
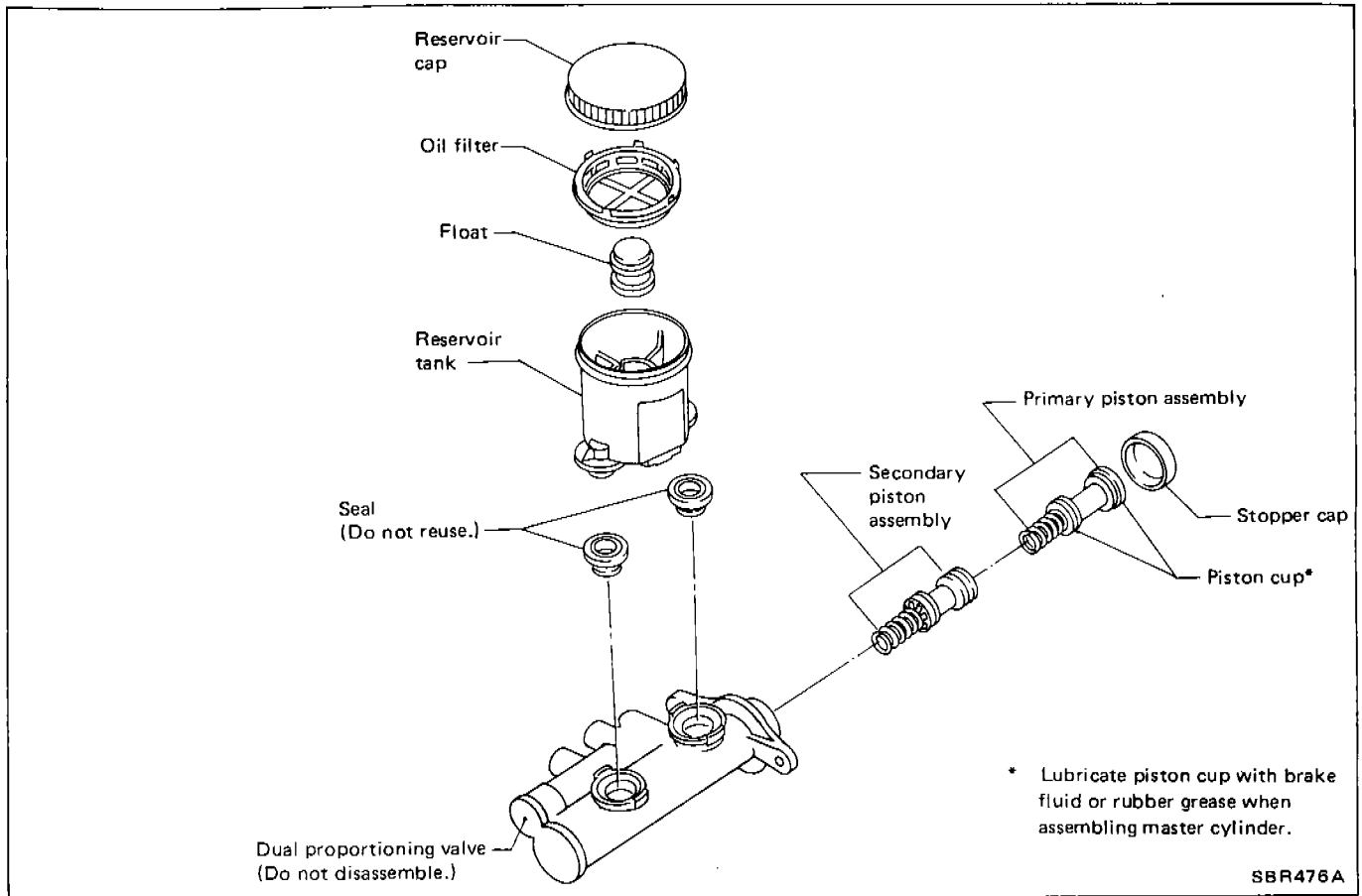

- Replace stopper cap if claw is damaged or deformed.
- Bend claws inward when installing stopper cap.

- Pay attention to direction of piston cups in figure at left.
- Check parts for wear or damage. Replace if necessary.

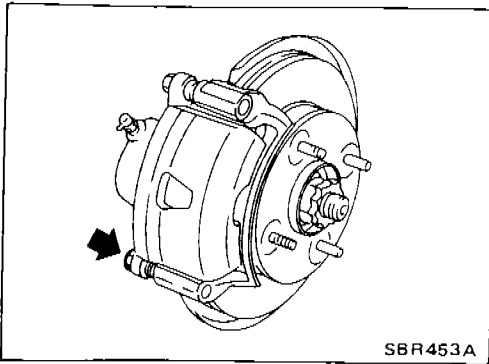

Pad Replacement

1. Remove pin bolt.

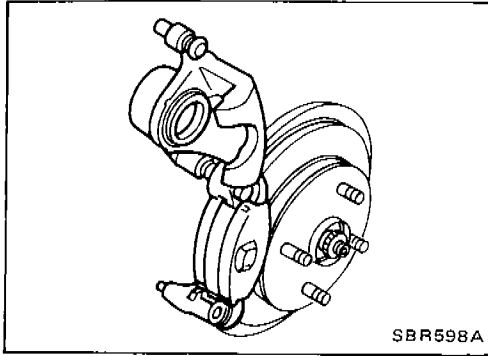

2. Swing cylinder body upward. Then remove pad retainer, and inner and outer shims.

CAUTION:

- When cylinder body is swung up, do not depress brake pedal because piston will pop out.
- Be careful not to damage dust seal or get oil on rotor. Always replace shims when replacing pads.

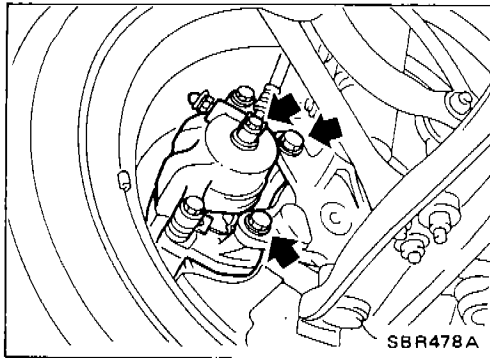

Removal and Installation

- Remove torque member fixing bolts and union bolt.

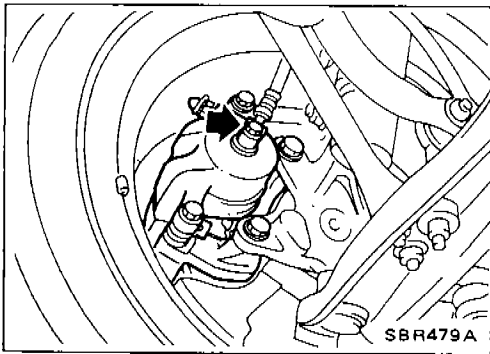

- Install brake hose to caliper at protrusions securely.

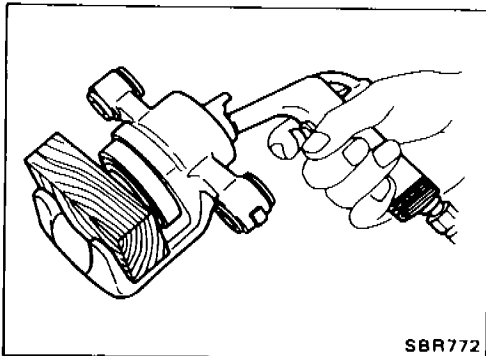

Disassembly

Push out piston with dust seal using compressed air.

Inspection

CYLINDER BODY

- Check inside surface of cylinder for scoring, rust, wear, damage or foreign materials. Replace if any such condition exists.
- Eliminate minor damage from rust or foreign materials by polishing surface with fine emery paper.

CAUTION:

Use brake fluid to clean.

PISTON

Check piston for scoring, rust, wear, damage or foreign materials. Replace if any condition exists.

CAUTION:

Piston sliding surface is plated. Do not polish with emery paper even if rust or foreign materials are stuck to sliding surface.

PIN, PIN BOLT AND PIN BOOT

Check for wear, cracks or other damage. Replace if any condition exists.

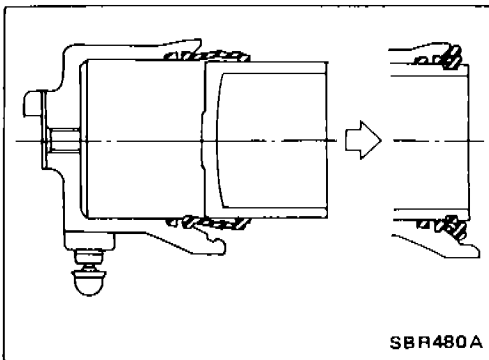

SBR480A

Assembly

- Place piston boot over rear of piston. Fit piston boot's lip properly in corresponding groove on cylinder body.
- Insert piston into cylinder body and fit boot's lip properly in corresponding groove on piston.

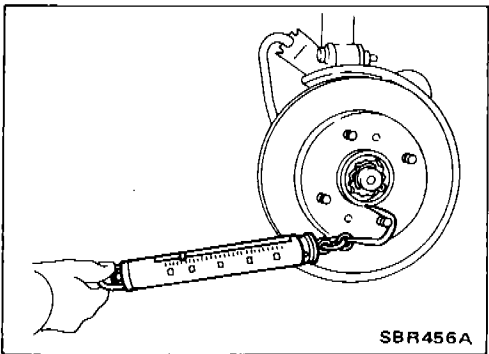

SBR456A

Inspection (On-vehicle)

INSPECTION OF BRAKE DRAG FORCE

1. Swing cylinder body upward.
2. Make sure that wheel bearing is adjusted properly. Refer to section FA.
3. Measure rotating force (F_1).

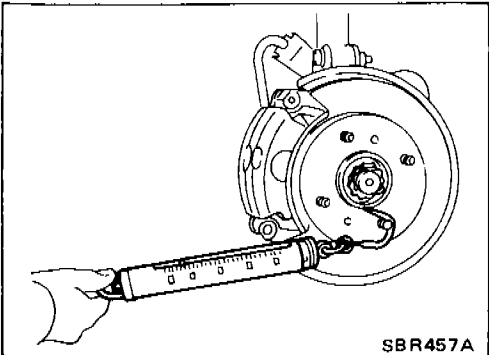

SBR457A

4. Install caliper with pads to original position.
5. Depress brake pedal for 5 seconds.
6. Release brake pedal and rotate disc rotor 10 revolutions.
7. Measure rotating force (F_2).
8. Calculate brake drag force by subtracting F_1 from F_2 .

Maximum brake drag force ($F_2 - F_1$):

59.8 N (6.1 kg, 13.5 lb)

If it is not within specification, check main pins and retainer boots in caliper.

FRONT DISC BRAKE (CL18VB, CL25VA) — Caliper

Inspection (On-vehicle) (Cont'd)

DISC PAD

Check disc pad for wear or damage.

CL18VB:

Pad standard thickness (A)

10.0 mm (0.394 in)

Pad wear limit (A)

2.0 mm (0.079 in)

CL25VA:

Pad standard thickness (A)

11.0 mm (0.433 in)

Pad wear limit (A)

2.0 mm (0.079 in)

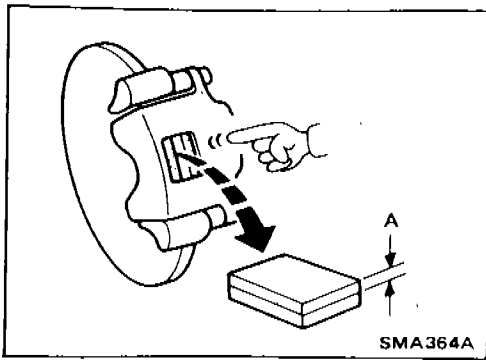

Inspection

RUBBING SURFACE

Check rotor for roughness, cracks or chips.

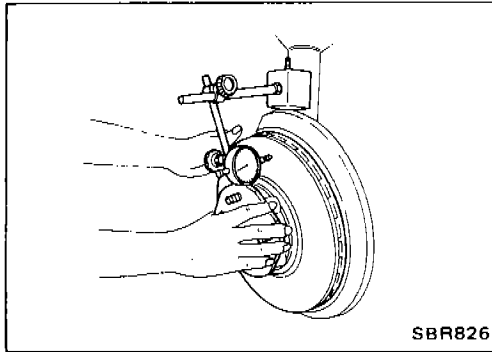

RUNOUT

Adjust wheel bearing preload. Check runout using a dial indicator.

Rotor repair limit:

Maximum runout

(Total indicator reading at center of rotor pad contact surface)

0.07 mm (0.0028 in)

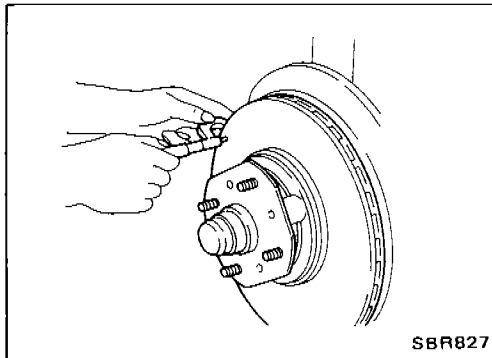

THICKNESS

CL18VB:

Standard thickness

18.0 mm (0.709 in)

Minimum thickness

16.0 mm (0.630 in)

CL25VA:

Standard thickness

22.0 mm (0.866 in)

Minimum thickness

20.0 mm (0.787 in)

REAR DISC BRAKE (CL9H) — Caliper

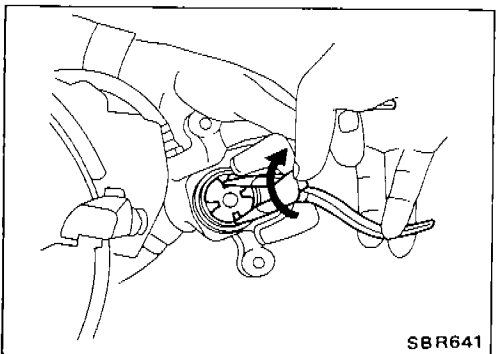
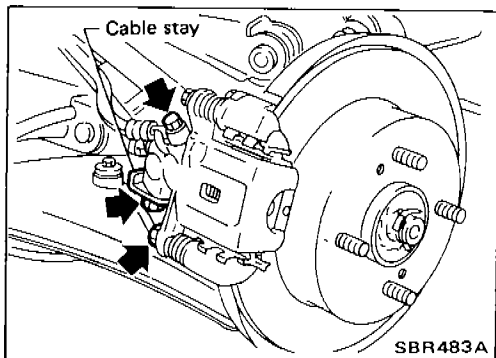
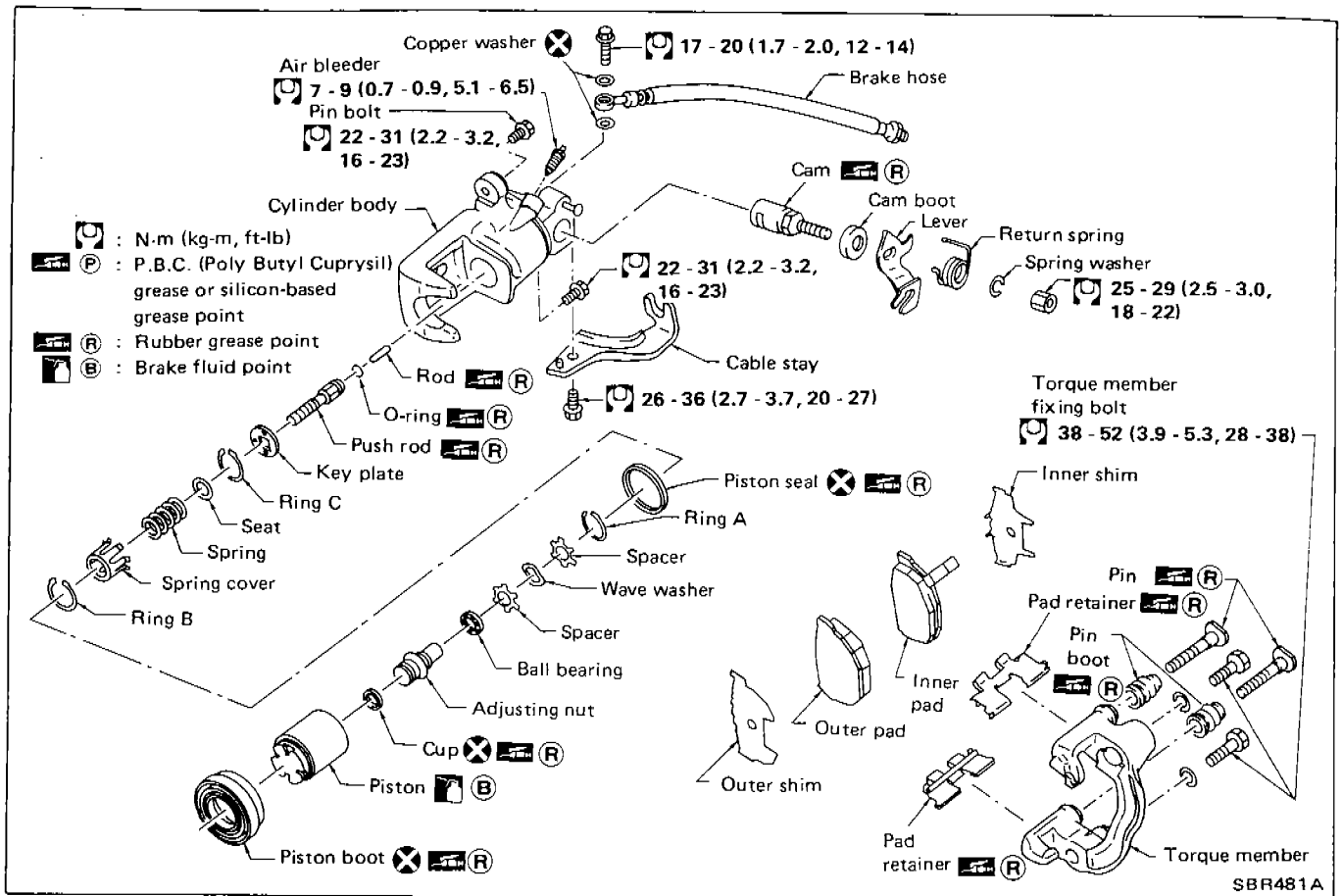

Pad Replacement

CAUTION:

When cylinder body is swung up, do not depress brake pedal because piston will pop out.

- Remove parking cable stay fixing bolt, pin bolts and lock spring. Then remove pad retainers, pads and shims.

- When installing pads, retract piston into cylinder body by turning it clockwise.

CAUTION:

Be careful not to damage piston boot or get oil on rotor. Always replace shims when replacing pads.

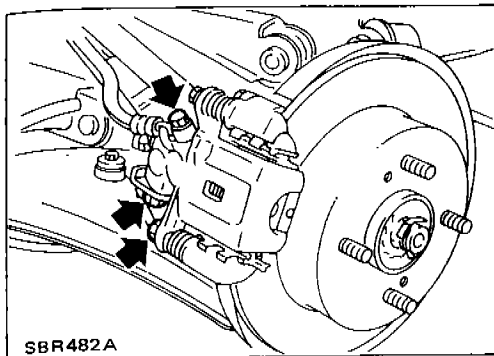

Removal and Installation

Disconnect parking brake cable and brake hose, then remove caliper assembly.

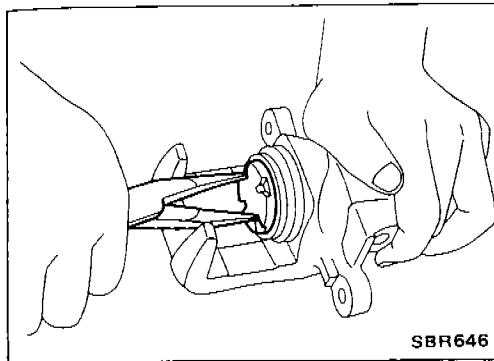

Disassembly

1. Remove piston by turning it counterclockwise with suitable longnose pliers.

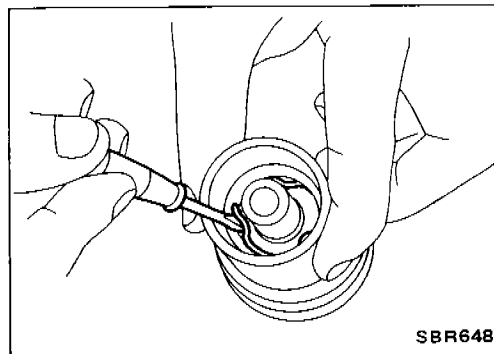

2. Pry off ring A from piston with suitable pliers and remove adjusting nut.

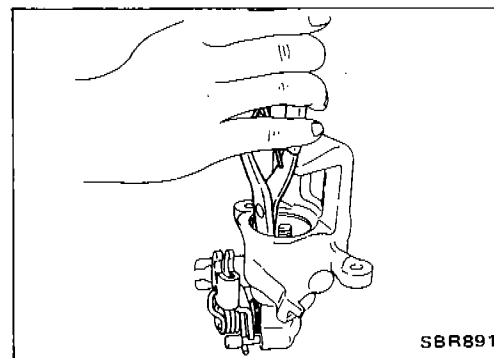

3. Disassemble cylinder body.

- Pry off rings B and C with pliers, then remove spring cover, spring and seat.

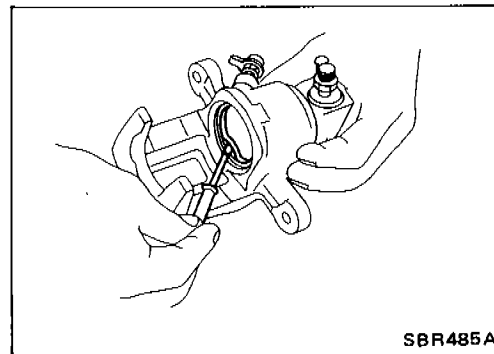

- Remove piston seal.

Be careful not to damage cylinder body.

REAR DISC BRAKE (CL9H) — Caliper

Disassembly (Cont'd)

4. Remove return spring and lever.

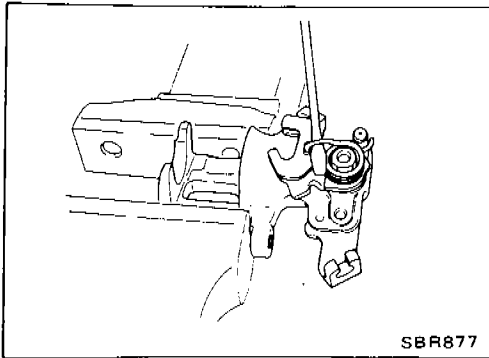

Inspection

CYLINDER BODY

- Check inside surface of cylinder for score, rust, wear or other damage.
- Minor damage from rust of foreign materials may be eliminated by polishing surface with a fine emery paper. Replace if necessary.

CAUTION:

Use brake fluid to clean.

TORQUE MEMBER

Check for wear, cracks or other damage. Replace if necessary.

PISTON

Check piston for score, rust, wear or other damage. Replace if necessary.

CAUTION:

Piston sliding surface is plated. Do not polish with emery paper even if rust or foreign matter is stuck to sliding surface.

PIN AND PIN BOOT

Check for wear, cracks or other damage. Replace if necessary.

Assembly

- Install cup securely in the specified direction.

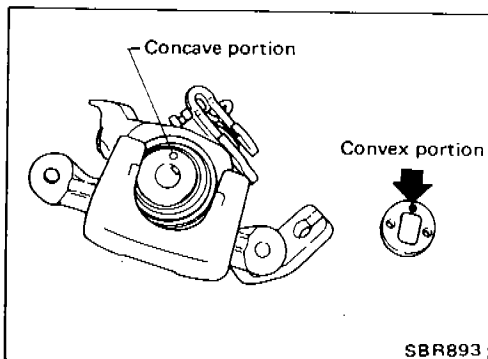
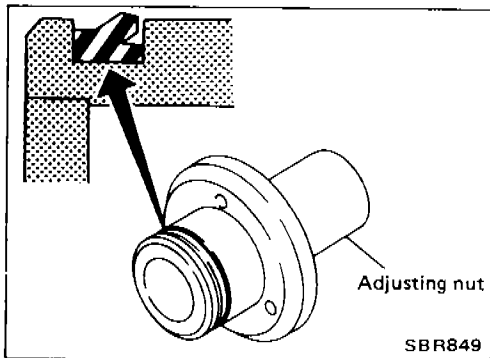

- Fit push rod into square hole in key plate. Also match convex portion of key plate with concave portion of cylinder.

REAR DISC BRAKE (CL9H) — Caliper

Assembly (Cont'd)

- Install ring C with suitable tool.

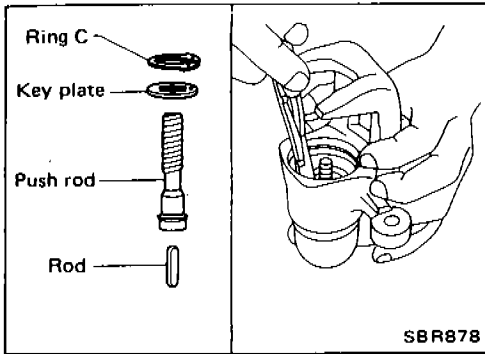

- Install seat, spring, spring cover and ring B with suitable press and drift.

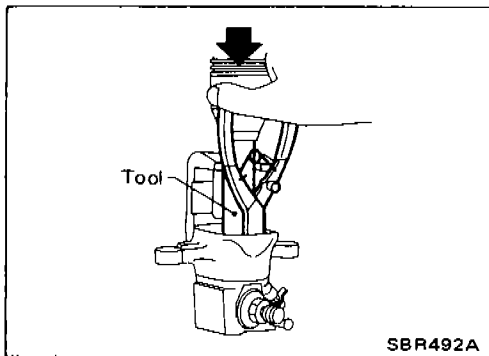

Inspection (On-vehicle)

INSPECTION OF BRAKE DRAG FORCE

1. Swing cylinder body upward.
2. Make sure that wheel bearing is adjusted properly. Refer to section RA.
3. Measure rotating force (F_1).

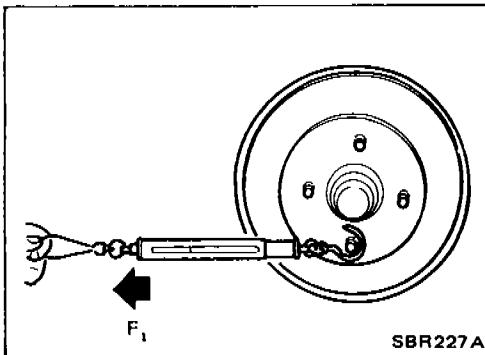

4. Install caliper with pads to original position.
5. Depress brake pedal for 5 seconds.
6. Release brake pedal, rotate disc rotor 10 revolutions.
7. Measure rotating force (F_2).
8. Calculate brake drag force by subtracting F_1 from F_2 .

Maximum brake drag force ($F_2 - F_1$):

86.3 N (8.8 kg, 19.4 lb)

If it is not within specification, check pins and pin boots in caliper.

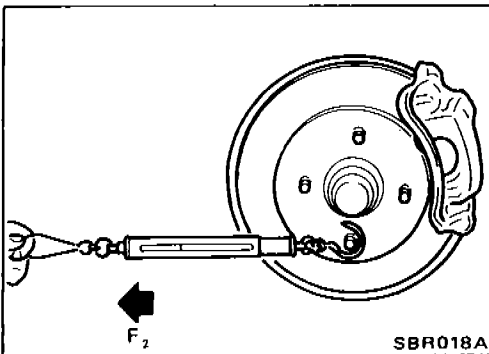

DISC PAD

Check disc pad for wear or damage.

Standard thickness (A):

9.5 mm (0.374 in)

Pad wear limit (A):

2.0 mm (0.079 in)

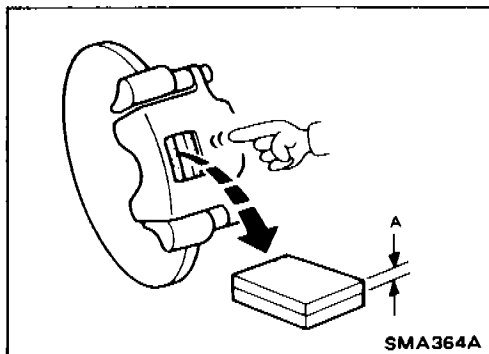

REAR DISC BRAKE (CL9H) — Rotor

Inspection

RUBBING SURFACE

Check rotor for roughness, cracks or chips.

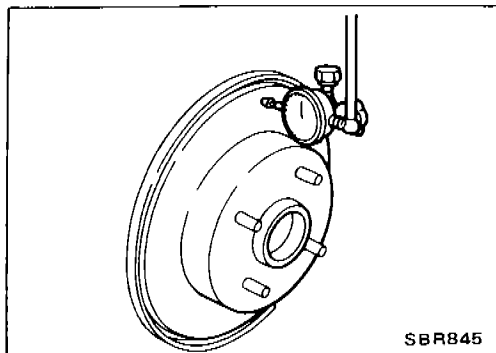

RUNOUT

- Check runout using a dial indicator.
- Make sure that axial end play is within the specifications before measuring. Refer to section RA.

Rotor repair limit:

Maximum runout

(Total indicator reading at center of rotor pad contact surface)

0.07 mm (0.0028 in)

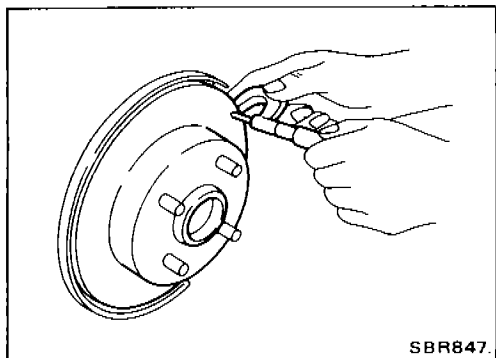

THICKNESS

Rotor repair limit:

Minimum thickness

8.0 mm (0.315 in)

REAR DISC BRAKE (AD9) — Caliper

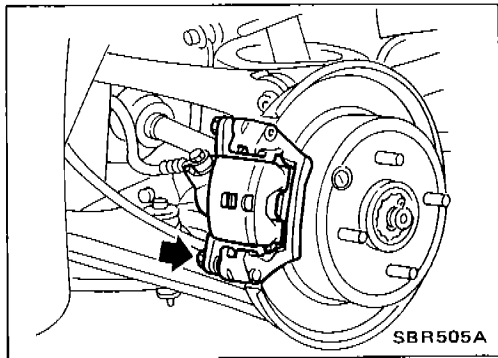
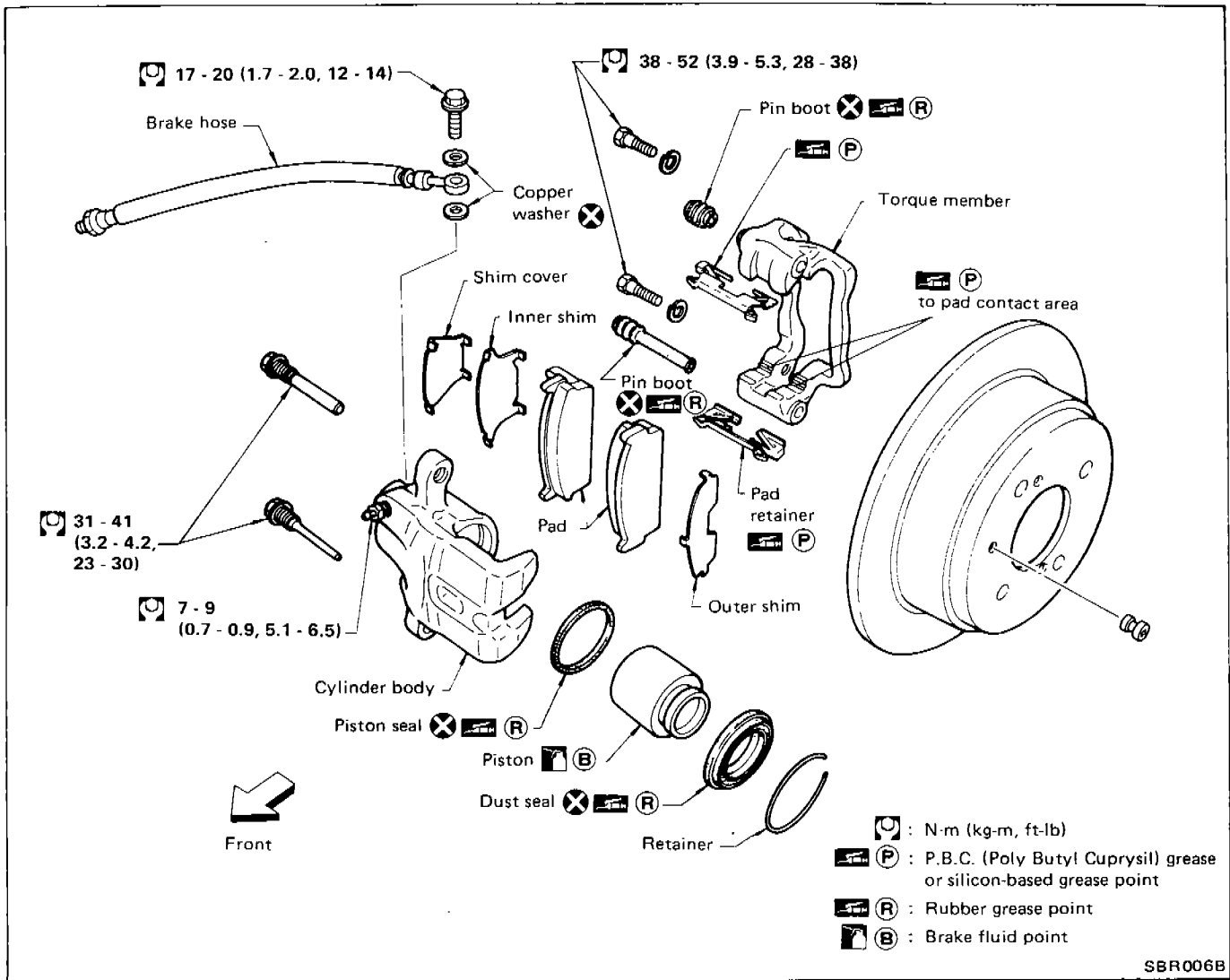

Pad Replacement

1. Remove guide pin.

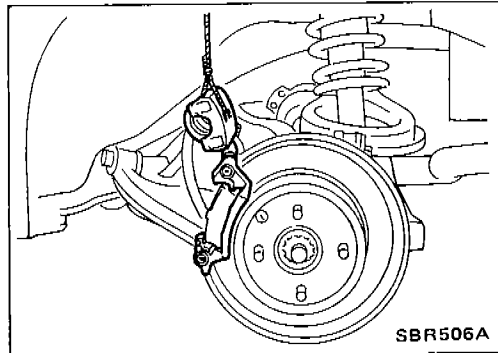

2. Swing cylinder body upward. Then remove pad retainer and inner and outer shims.

CAUTION:

- When cylinder body is swung up, do not depress brake pedal because piston will pop out.
- Be careful not to damage dust seal or get oil on rotor. Always replace shims when replacing pads.

REAR DISC BRAKE (AD9) — Caliper

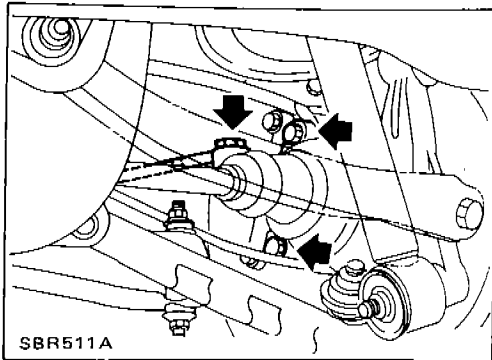

Removal and Installation

- Remove torque member fixing bolts and eye bolt.

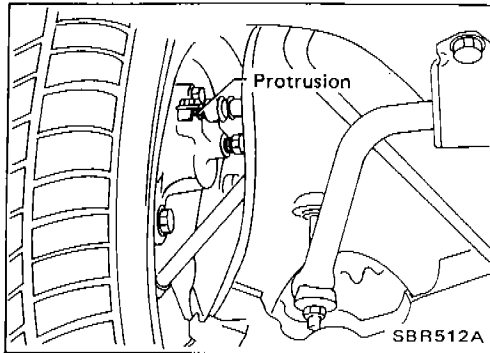

- Install brake hose to caliper securely.

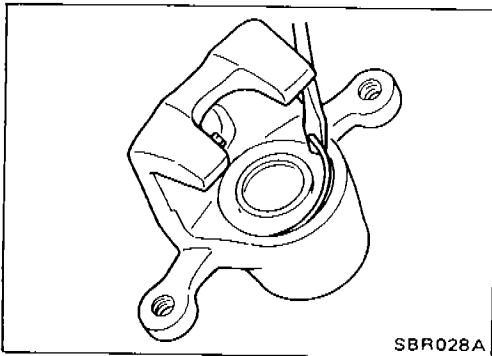

- Remove retainer with a screwdriver.

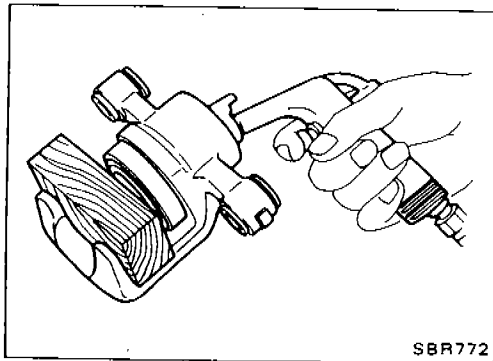

- Push out piston with dust seal with compressed air.

REAR DISC BRAKE (AD9) — Caliper

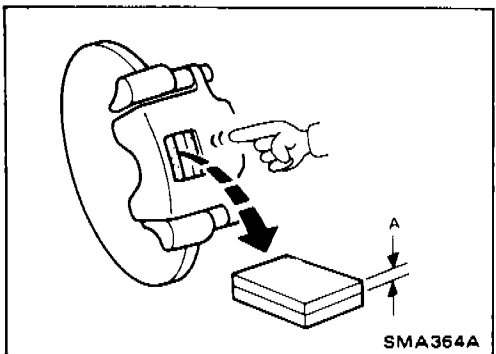
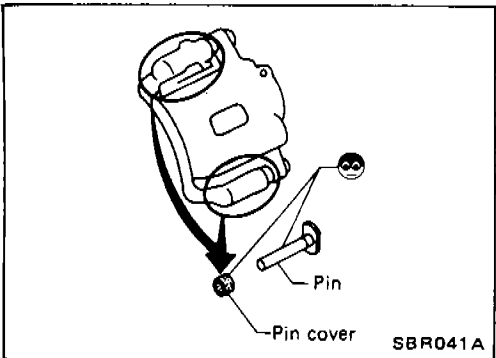
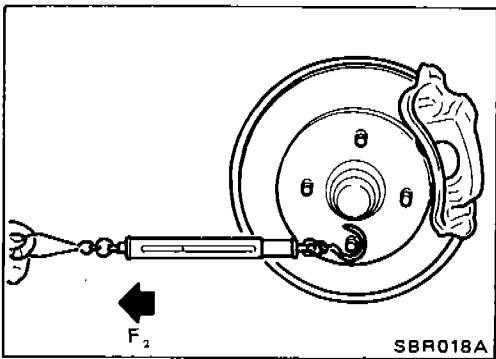
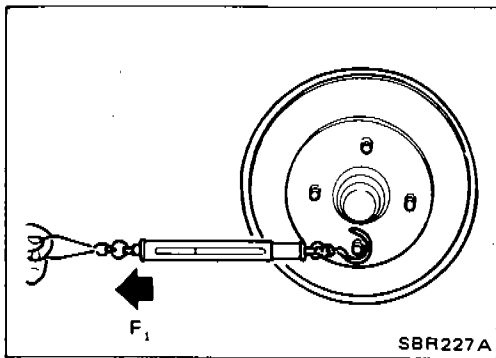

Inspection

INSPECTION OF BRAKE DRAG FORCE

1. Swing cylinder body upward.
2. Make sure that wheel bearing is adjusted properly. Refer to section RA.
3. Measure rotating force (F_1).

4. Install caliper with pads to original position.
5. Depress brake pedal for 5 seconds.
6. Release brake pedal, rotate disc rotor 10 revolutions.
7. Measure rotating force (F_2).
8. Calculate brake drag force by subtracting F_1 from F_2 .

Maximum brake drag force ($F_2 - F_1$):
103.0 N (10.5 kg, 23.2 lb)

If it is not within specification, check pins and pin boots in caliper.

- Make sure that wheel bearing is adjusted properly.
- Disc pads and disc rotor must be dried.

DISC PAD

Check disc pad for wear or damage.

Pad wear limit (A):
2.0 mm (0.079 in)

CYLINDER BODY

- Check inside surface of cylinder body for score, rust, wear, damage or presence of foreign materials. If any of the above conditions are observed, replace cylinder body.
- Minor damage from rust or foreign materials may be eliminated by polishing surface with a fine emery paper. Replace cylinder body if necessary.

CAUTION:

Use brake fluid to clean. Never use mineral oil.

Inspection (Cont'd)

PISTON

Check piston for score, rust, wear, damage or presence of foreign materials. Replace if any of the above conditions are observed.

CAUTION:

Piston sliding surface is plated. Do not polish with emery paper even if rust or foreign matter is stuck to sliding surface.

PIN, PIN BOLT, RETAINER, PISTON SEAL, DUST SEAL AND PIN BOOT

Check for wear, cracks or other damage. Replace if any of the above conditions are observed.

Assembly

- With dust seal fitted to piston, insert dust seal into groove on cylinder body and install piston.
- Properly secure dust seal.

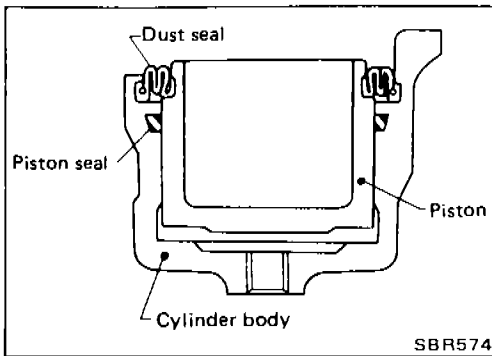

REAR DISC BRAKE (AD9) — Rotor

Inspection

RUBBING SURFACE

Check rotor for roughness, cracks or chips. Repair or replace if necessary.

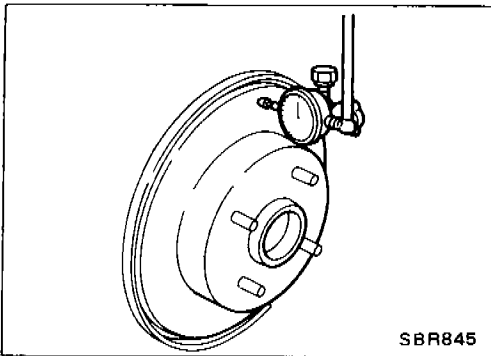

RUNOUT

Make sure that axial end play is within the specifications before measuring. Refer to section RA.

Then check runout using a dial indicator.

Rotor repair limit:

Maximum runout

(Total indicator reading at center of rotor pad contact surface)

0.07 mm (0.0028 in)

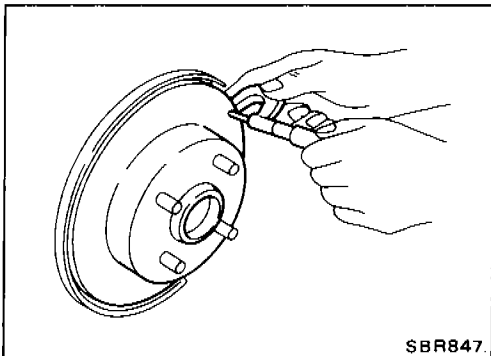

THICKNESS

Rotor repair limit:

Minimum thickness

8.0 mm (0.315 in)

PARKING BRAKE CONTROL

Removal and Installation

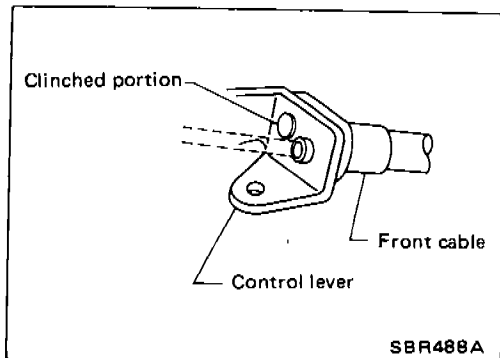
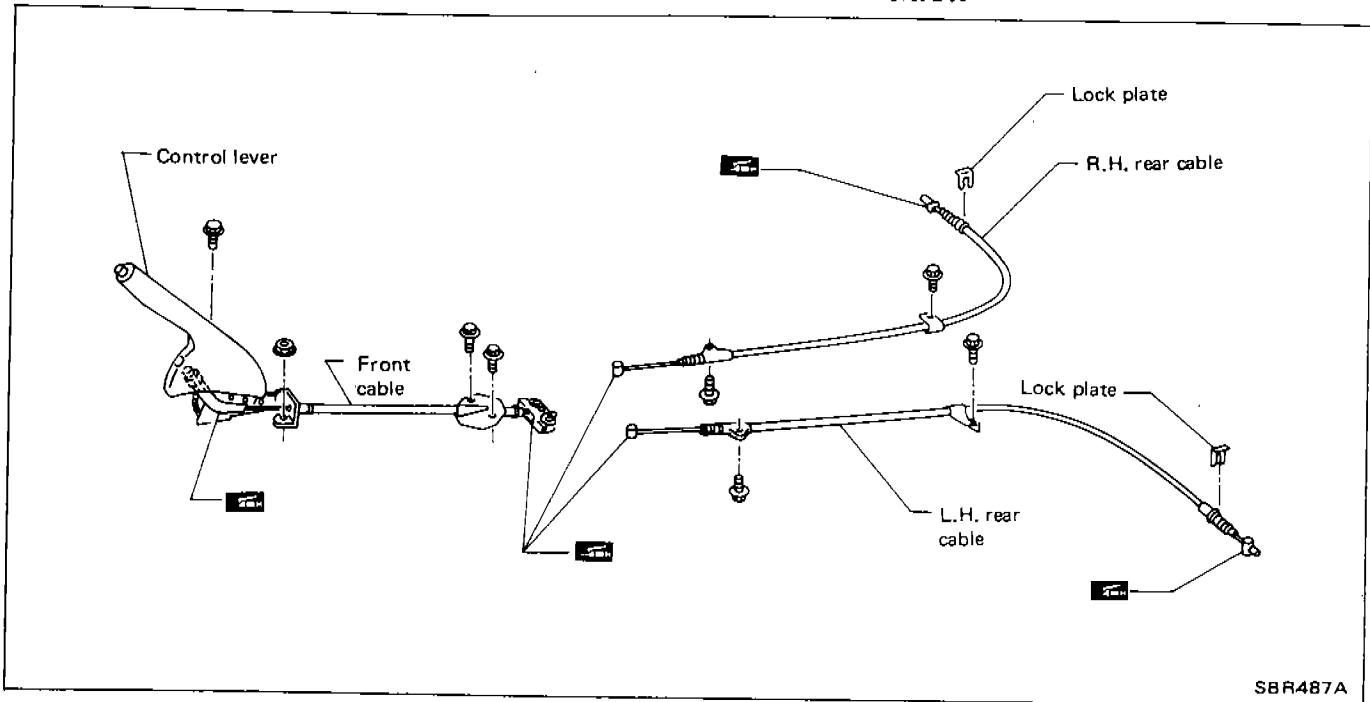

REMOVAL

- Before removing parking brake control, remove console box.
- Loosen cable using control lever adjuster, and separate front and rear cables.
- Break clinched portion of control lever using a hammer and chisel as shown in figure at left, and replace cables with new parts.

Apply multi-purpose grease to areas between control lever drum and cables.

INSTALLATION

Be careful not to damage boot and inner cable.

- When installing parking brake cable at rear caliper, make sure to align matchmark on parking cable stay and cable.

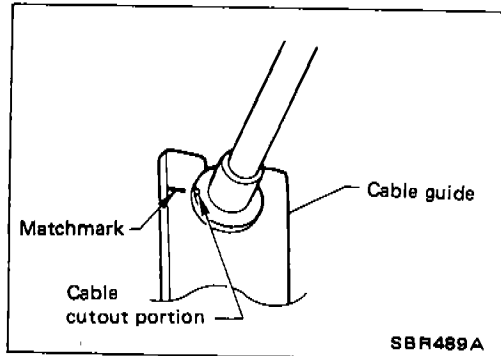

Inspection

1. Check control lever for wear or other damage. Replace if necessary.
2. Check parking brake cables, lamp and switch. Replace if necessary.
3. Check parts at each connecting portion for deformation or damage. If found, replace.

PARKING BRAKE CONTROL

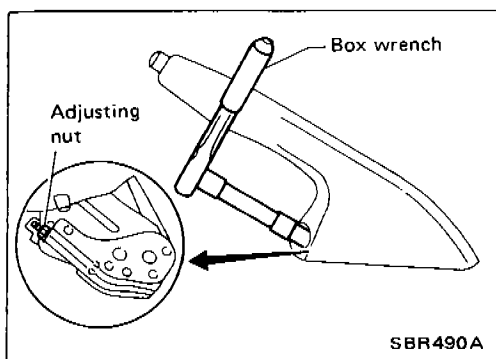

Adjustment

1. Ensure that parking brake releases when control lever is pulled down completely. If control lever does not release parking brake, proceed as follows:
 - Pull control lever up by 4 or 5 notches.
 - Insert a box wrench into opening in control lever and loosen self-lock adjusting nut to slacken cables. Completely push control lever down.
2. Forcefully depress brake pedal about five times (so that caliper is automatically set in position.).
3. Pull lever up by 4 or 5 notches.
4. Turn adjusting nut as shown in figure at left and adjust lever stroke to specified value.
5. Completely push control lever down and ensure that:
 - Parking brake is released completely.
 - Rear brakes are free from dragging.

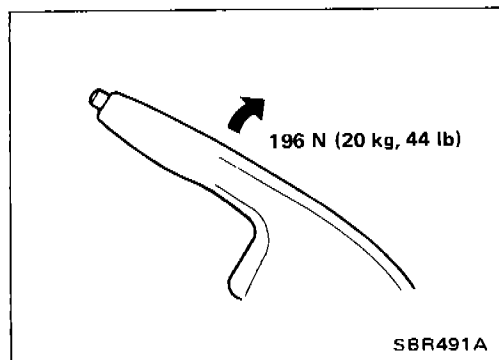

6. Pull control lever with specified amount of force. Check lever stroke and ensure smooth operation.

Number of notches: 6 - 8

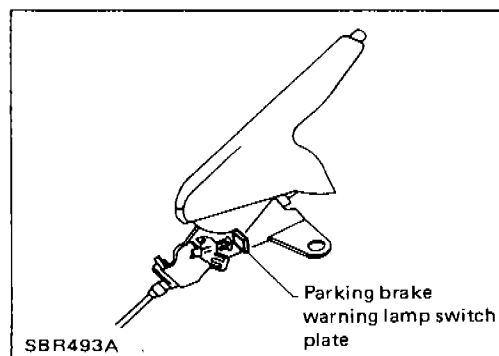

7. Bend parking brake warning lamp switch plate so that brake warning light comes on when ratchet at parking brake lever is pulled "A" notches and goes out when fully released.

Number of notches "A": 1

PARKING DRUM BRAKE (DS17HD) — Rear Disc Brake AD9 Model

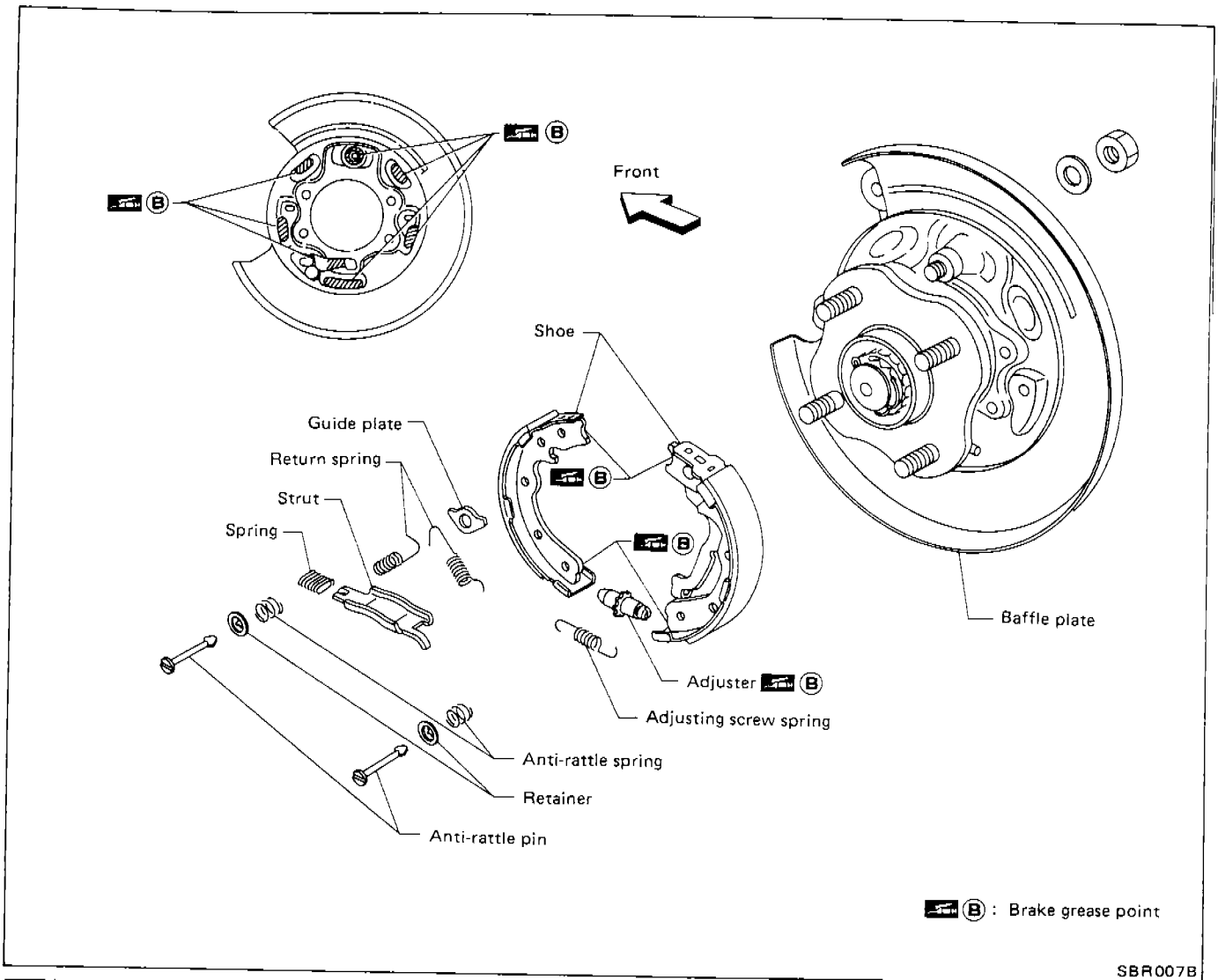

SBR007B

Shoe Replacement

1. Remove disc rotor (With parking drum brake).
Tighten two bolts gradually if disc rotor is hard to remove.

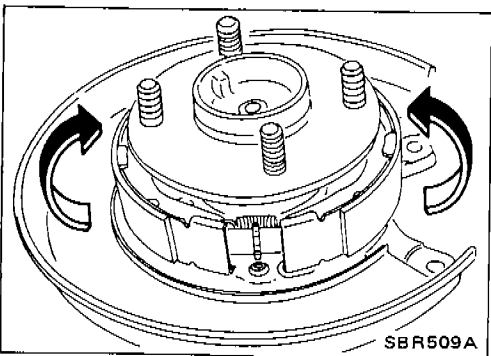
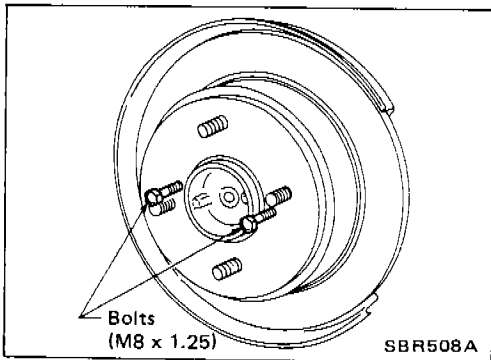

2. After removing retainer, remove spring by rotating shoes.
Be careful not to damage parking brake cable when separating it.

Breaking in Drum and Lining

1. Using either low or 2nd transmission speed, drive the unloaded vehicle at approximately 30 km/h (19 MPH) on a safe, level and dry road.
2. Depress the release button of parking brake lever, then pull the lever with a force of 98 N (10 kg, 22 lb).
3. While holding the lever back, continue to drive the vehicle 100 m (328 ft).
4. Repeat steps 1 through 3 two or three times.

Drum Inspection

- Standard inner diameter:**
172.0 mm (6.77 in)
- Maximum inner diameter:**
173.0 mm (6.81 in)
- Radial runout (Total indicator reading):**
0.07 mm (0.0028 in)

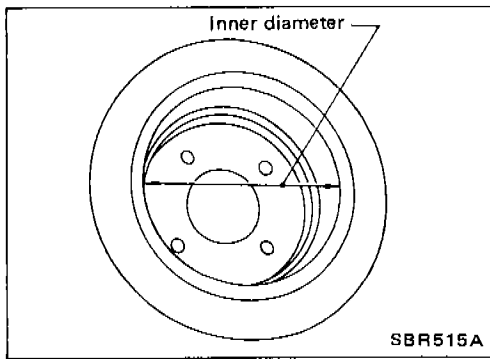

ANTI-LOCK BRAKING SYSTEM

System Components

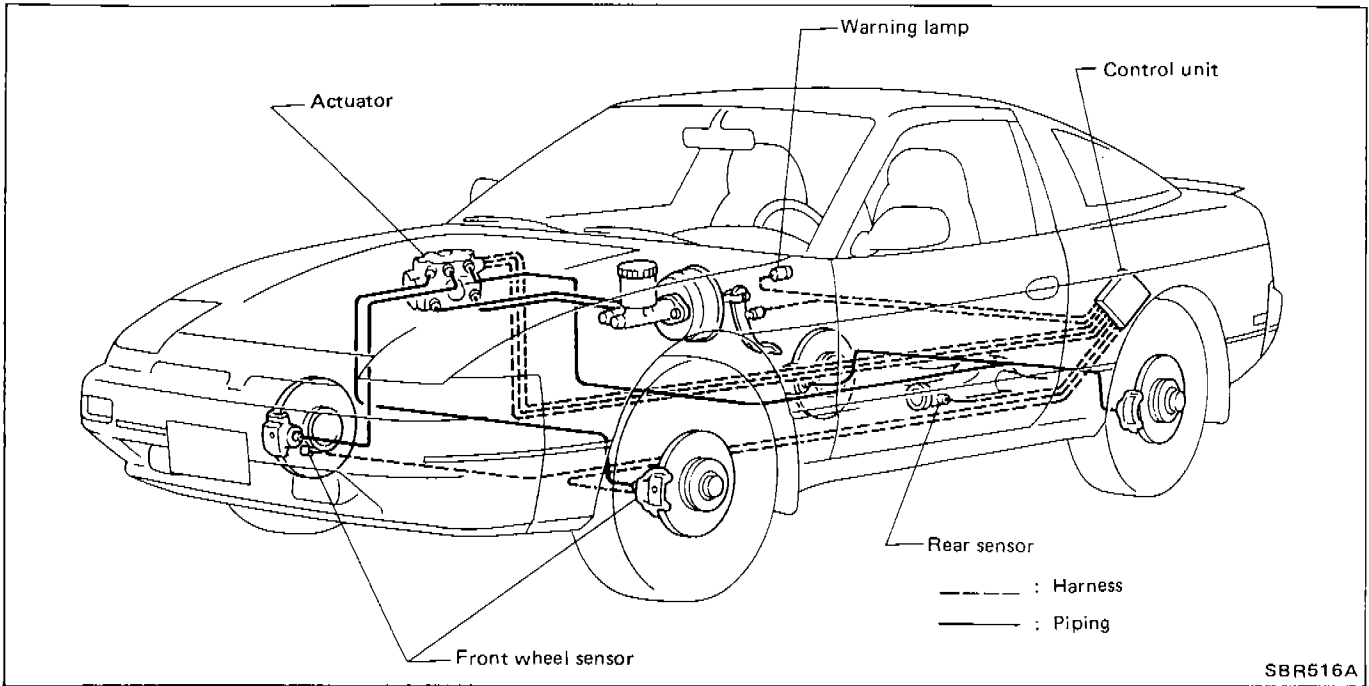

Hydraulic Circuit

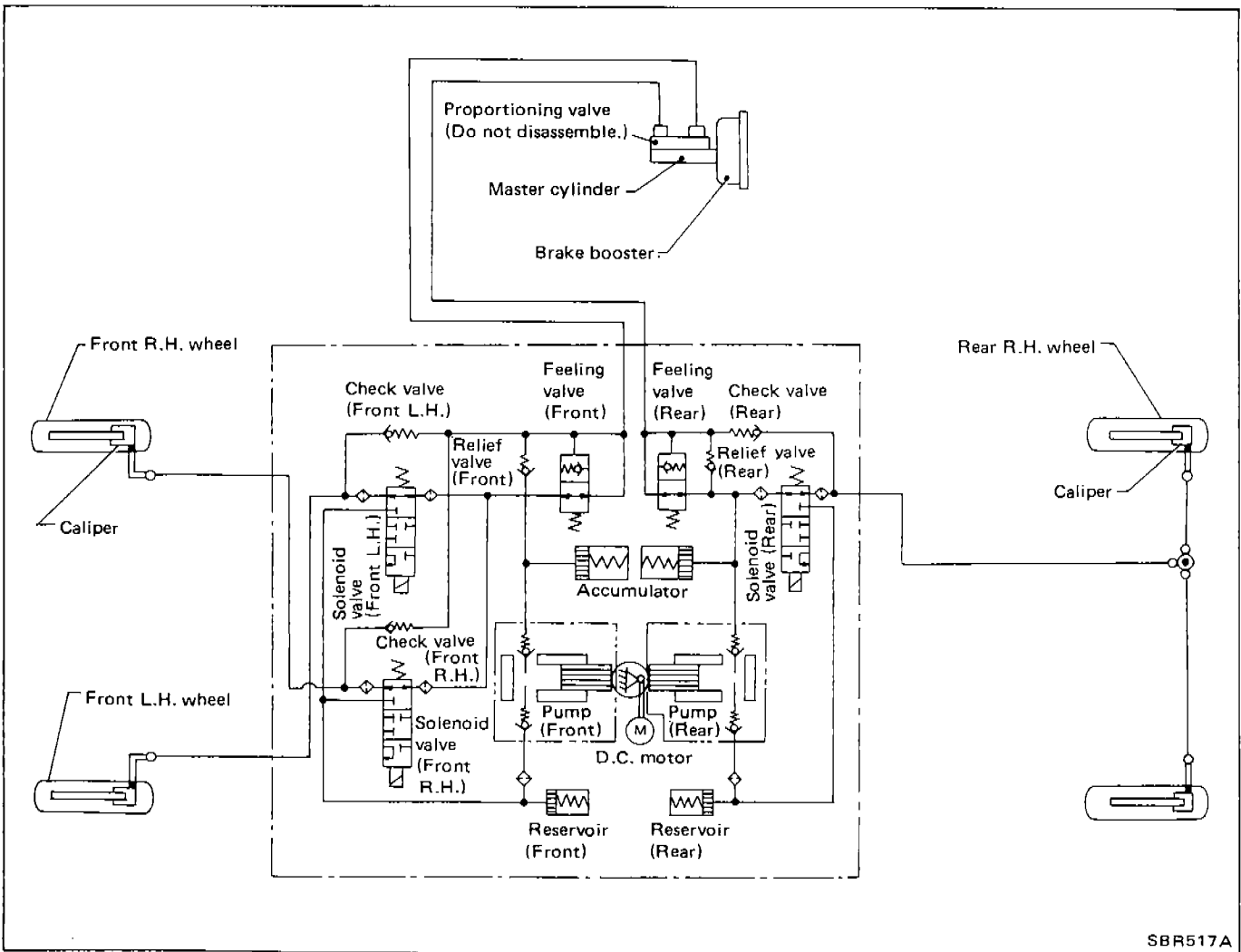

ANTI-LOCK BRAKING SYSTEM

L.H.D. MODEL

Wiring Diagram

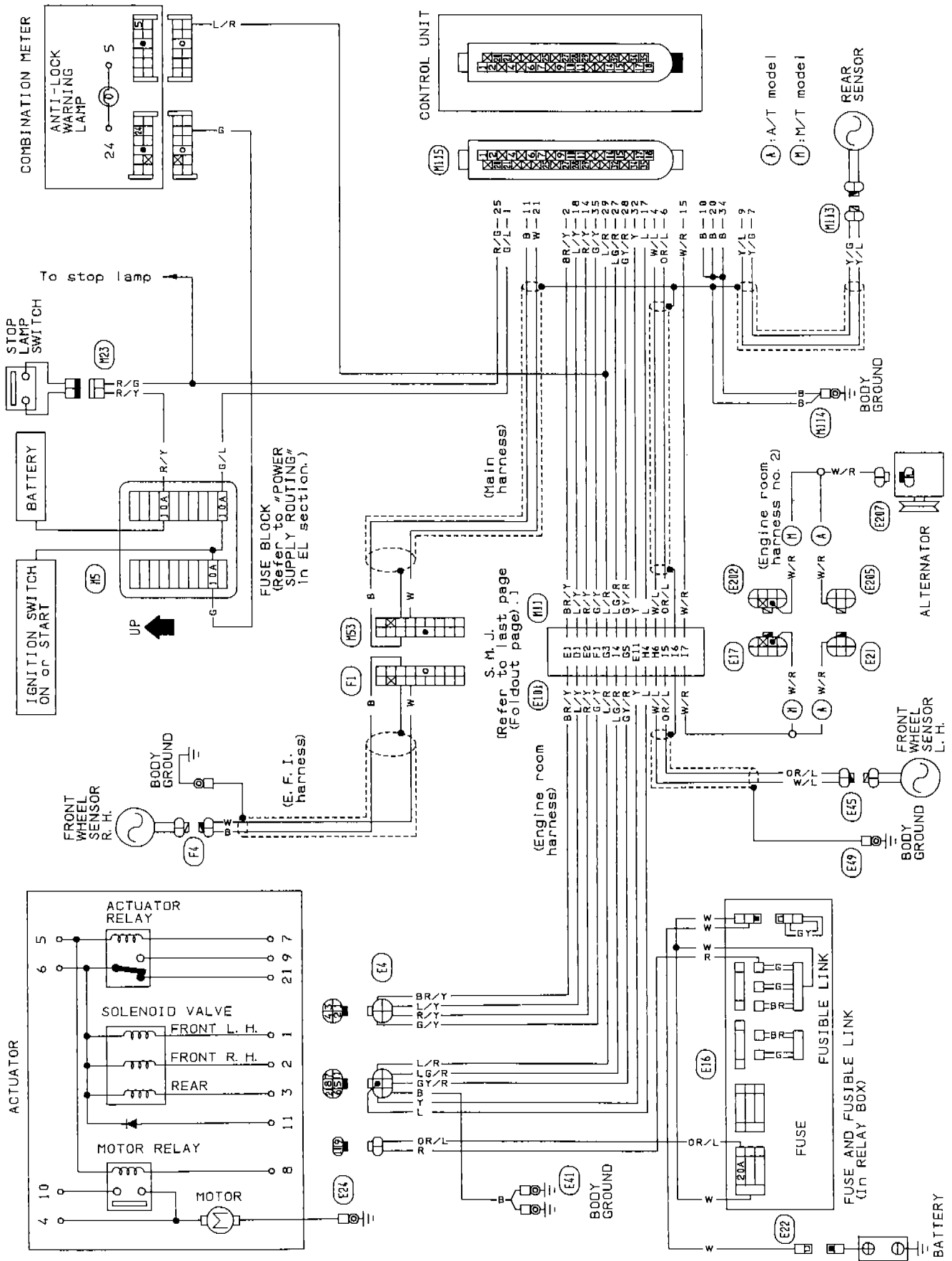

SBR538A

ANTI-LOCK BRAKING SYSTEM

L.H.D. MODEL

Wiring Diagram

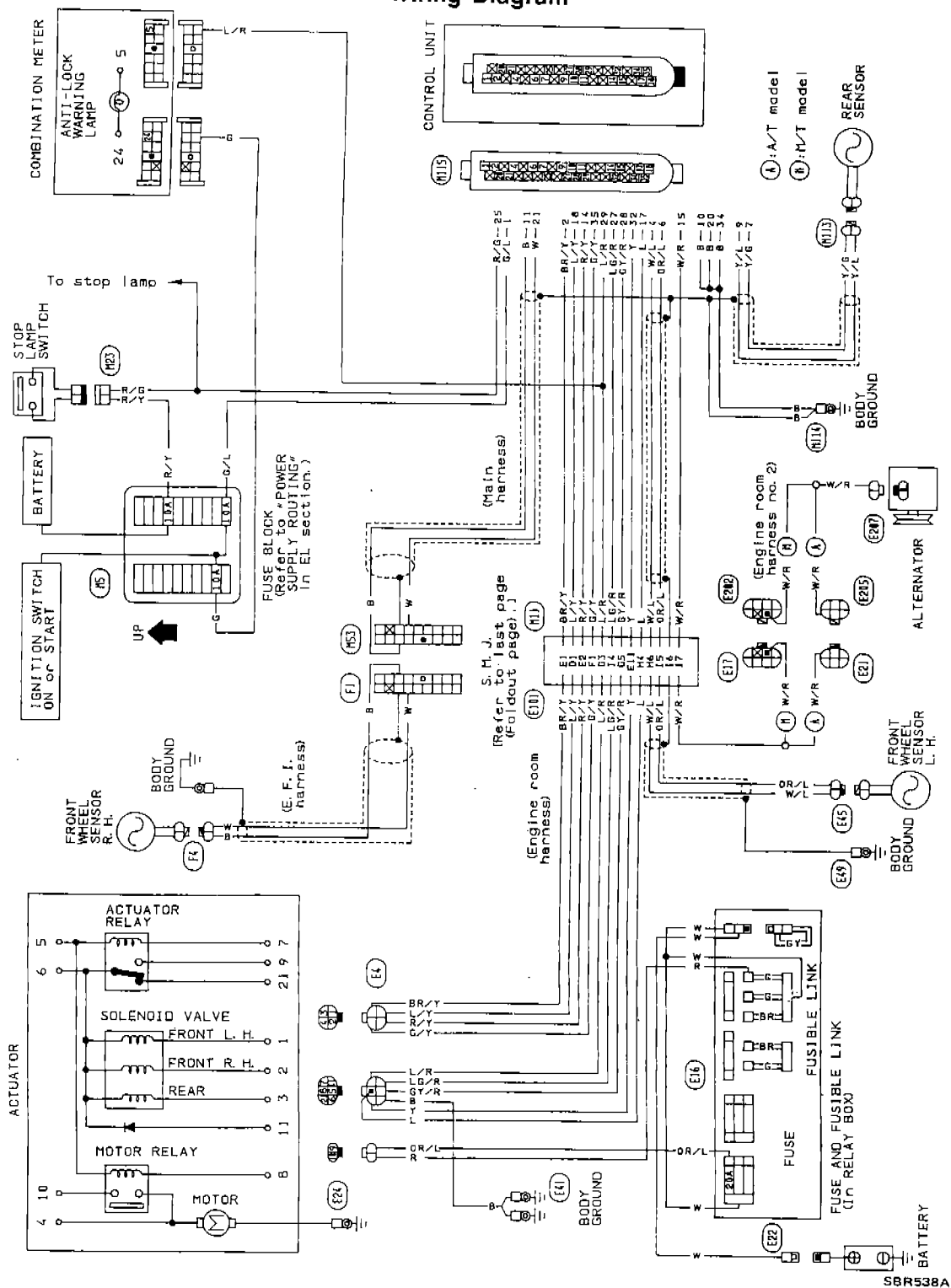

SBR538A

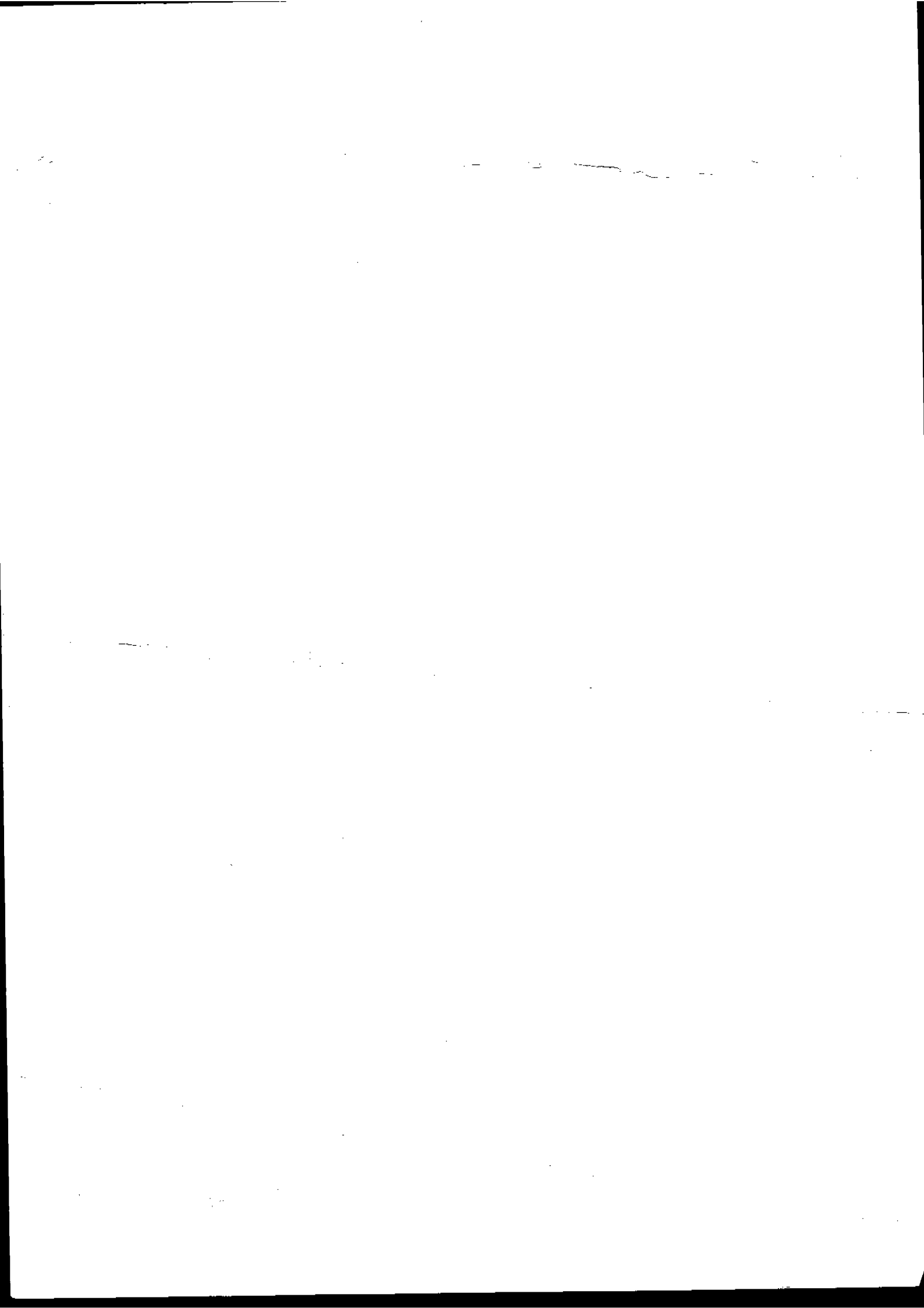

ANTI-LOCK BRAKING SYSTEM

Removal and Installation

CAUTION:

Be careful not to damage sensor edge and sensor rotor teeth.

FRONT WHEEL SENSOR

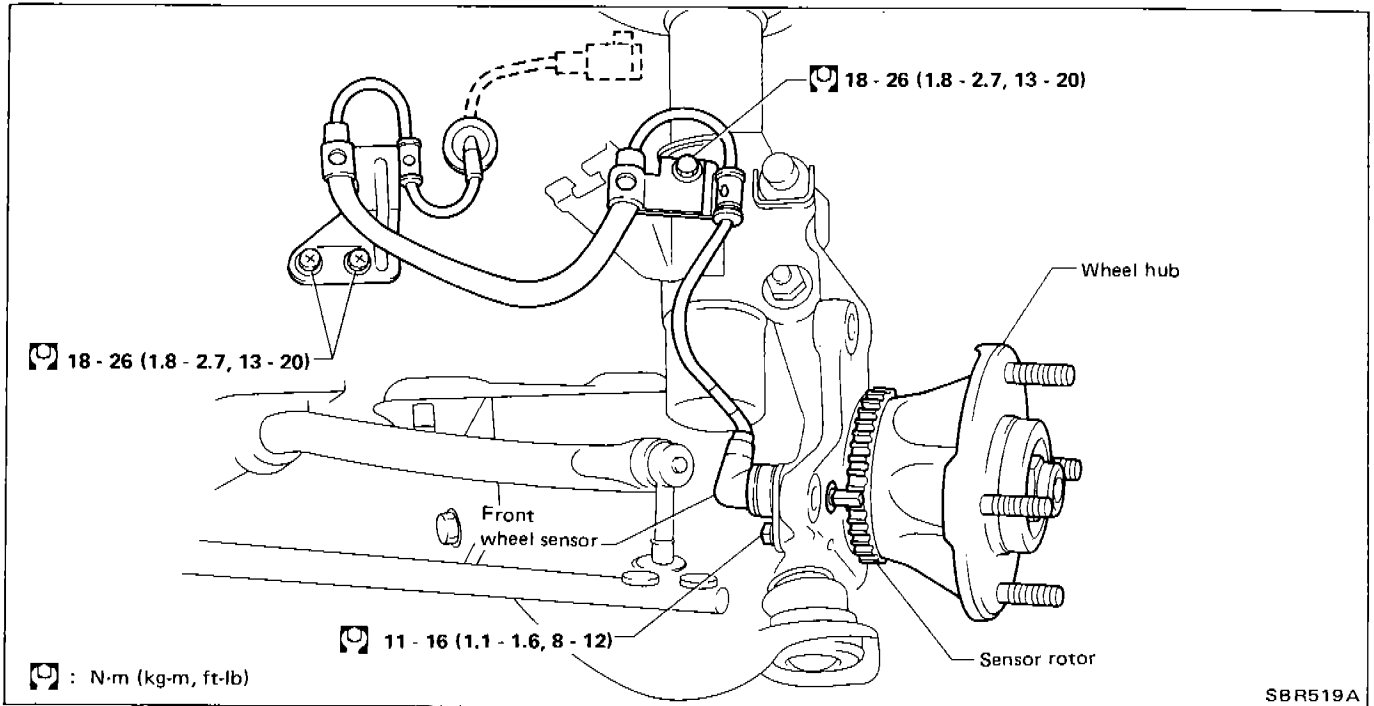

REAR SENSOR

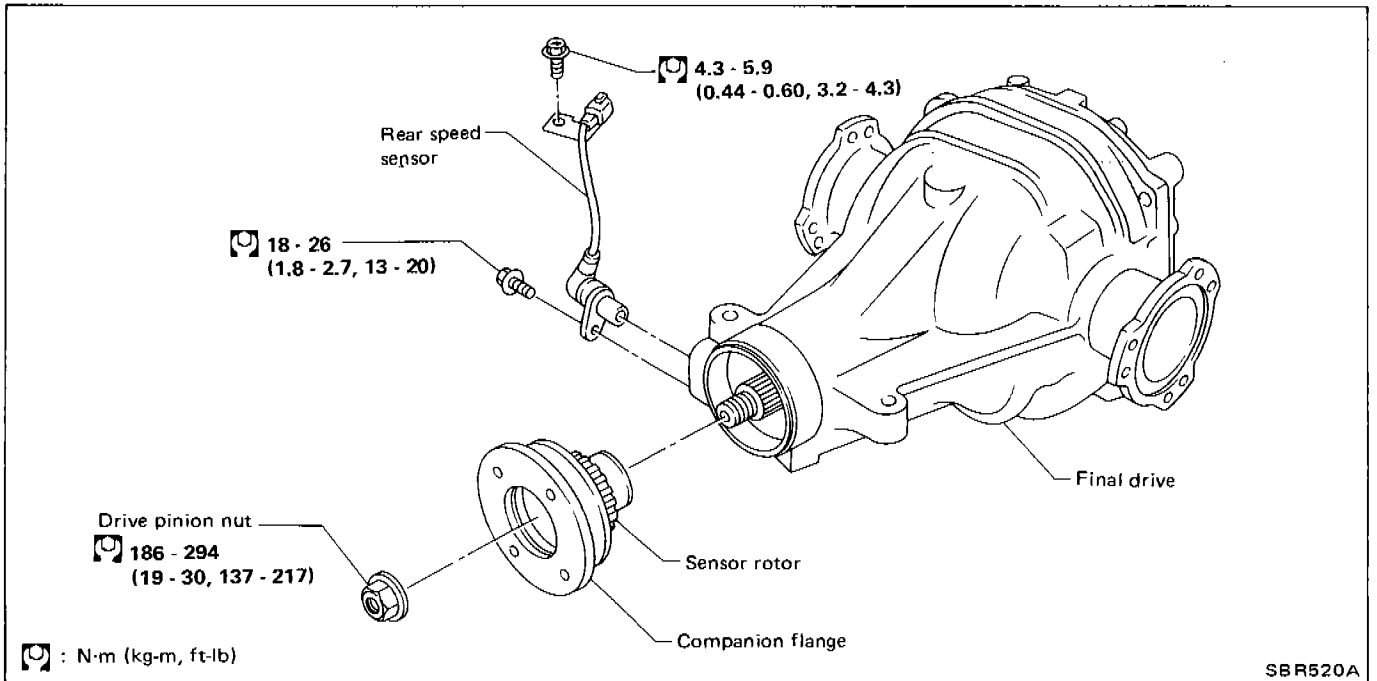

- Remove rear sensor rotor with companion flange after propeller shaft removal. Refer to PD section.

ANTI-LOCK BRAKING SYSTEM

Removal and Installation (Cont'd)

ACTUATOR

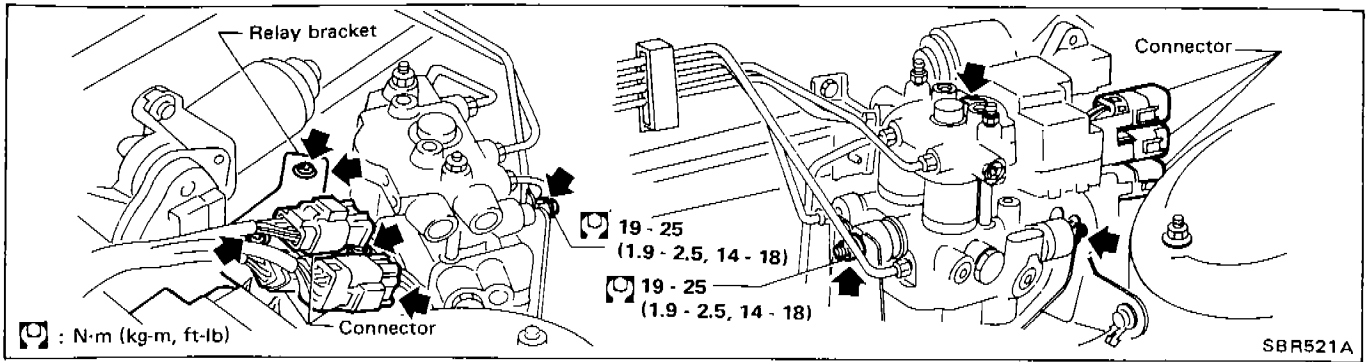

- Disconnect 3 connectors and brake tubes.
- For L.H. only, remove relay bracket 3 screws.
- Remove 3 nuts fixing actuator to bracket.

TROUBLE DIAGNOSES

Contents

| | |
|----------------------------------------------------------------------|-------|
| How to Perform Trouble Diagnoses for Quick and Accurate Repair | BR-38 |
| Symptom Chart | BR-41 |
| Preliminary Check 1 | BR-42 |
| Preliminary Check 2 | BR-43 |
| Preliminary Check 3, 4 | BR-44 |
| Self-diagnosis | BR-45 |
| Component Parts Location | BR-46 |
| Harness Connector Location | BR-47 |
| Ground Circuit Check | BR-48 |
| Circuit Diagram for Quick Pinpoint Check | BR-49 |
| Diagnostic Procedure 1 | BR-50 |
| Diagnostic Procedure 2 | BR-51 |
| Diagnostic Procedure 3 | BR-52 |
| Diagnostic Procedure 4 | BR-52 |
| Diagnostic Procedure 5 | BR-53 |
| Diagnostic Procedure 6 | BR-53 |
| Diagnostic Procedure 7 | BR-54 |
| Diagnostic Procedure 8 | BR-55 |
| Diagnostic Procedure 9 | BR-56 |
| Diagnostic Procedure 10 | BR-57 |
| Diagnostic Procedure 11 | BR-58 |
| Diagnostic Procedure 12 | BR-59 |
| Electrical Components Inspection | BR-60 |

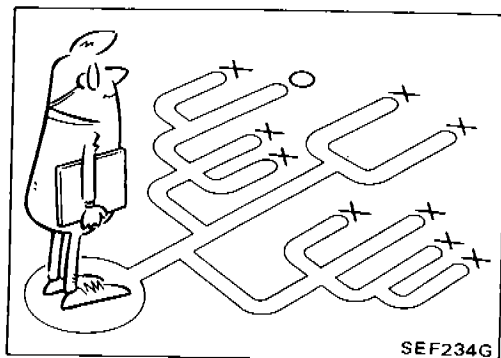
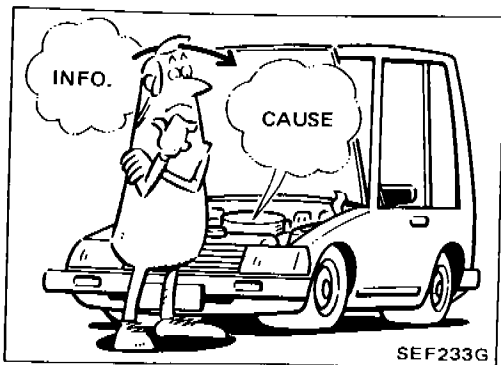

How to Perform Trouble Diagnoses for Quick and Accurate Repair

INTRODUCTION

The A.B.S. system has an electronic control unit to control major functions. The control unit accepts input signals from sensors and instantly drives actuators. It is essential that both kinds of signals are proper and stable. At the same time, it is important that there are no conventional problems such as air leaks in the booster or lines, lack of brake fluid, or other problems with brake system.

It is much more difficult to diagnose a problem that occurs intermittently rather than continuously. Most intermittent problems are caused by poor electric connections or faulty wiring. In this case, careful checking of suspicious circuits may help prevent the replacement of good parts.

A visual check only may not find the cause of the problems, so a road test should be performed.

Before undertaking actual checks, take just a few minutes to talk with a customer who approaches with a A.B.S. complaint. The customer is a very good source of information on such problems; especially intermittent ones. Through the talks with the customer, find out what symptoms are present and under what conditions they occur.

Start your diagnosis by looking for "conventional" problems first. This is one of the best ways to troubleshoot brake problems on an A.B.S. controlled vehicle.

TROUBLE DIAGNOSES

How to Perform Trouble Diagnoses for Quick and Accurate Repair (Cont'd)

WORK FLOW

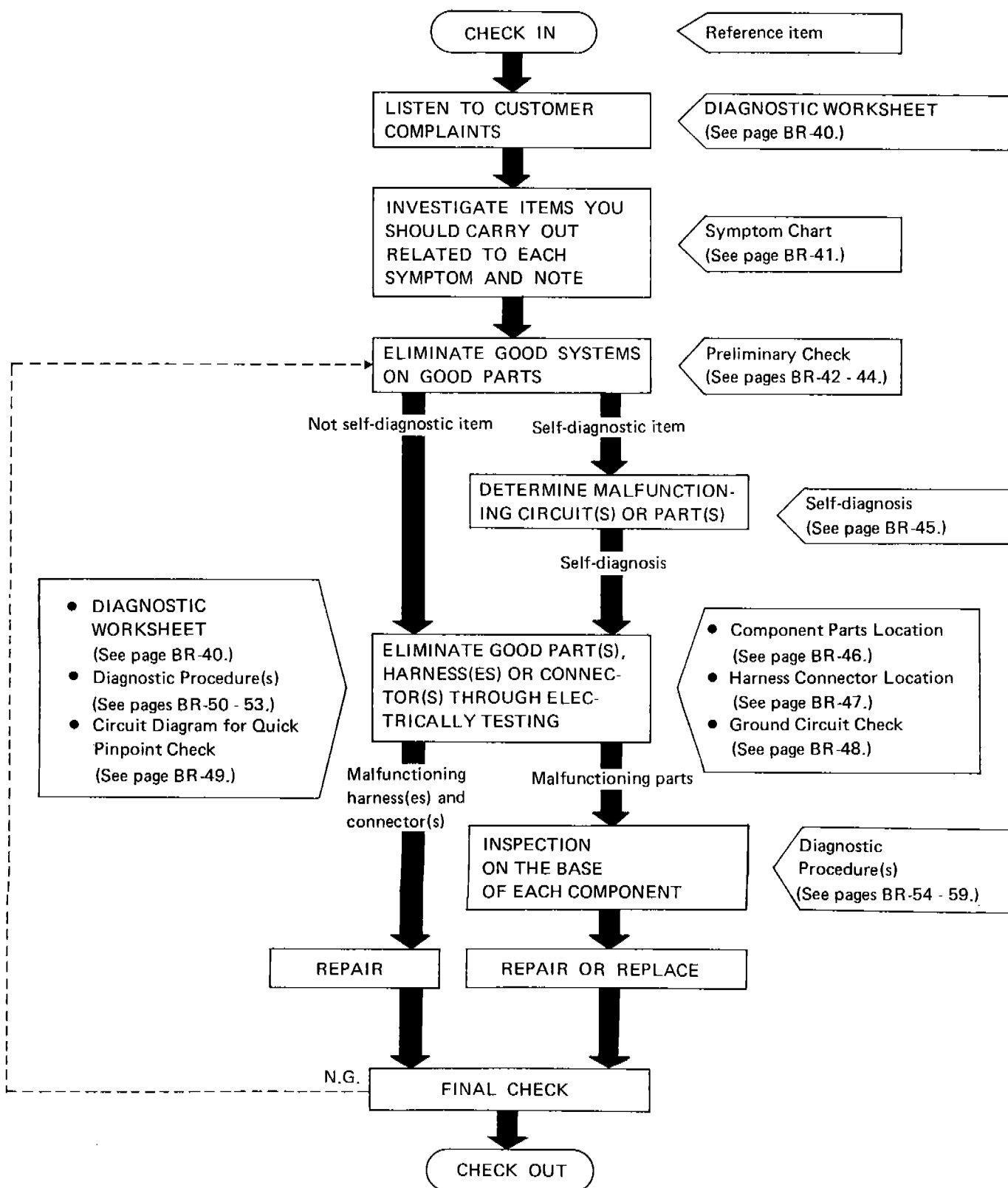

TROUBLE DIAGNOSES

Symptom Chart

| PROCEDURE | Preliminary Check | Diagnostic Procedure | | | | | | Diagnostic Procedure (Select inspection with L.E.D. flashing No.) | | | | | | Ground Circuit Check | Electrical Components Inspection | |
|----------------|------------------------------------|----------------------|-------|------------------------|-----------------------|---|--|----------------------------------------------------------------------|--|--|--|--|--|----------------------|----------------------------------|--|
| REFERENCE PAGE | BR-42 | Preliminary Check 1 | | | | | | | | | | | | | | |
| | BR-43 | Preliminary Check 2 | | | | | | | | | | | | | | |
| | BR-44 | Preliminary Check 3 | | | | | | | | | | | | | | |
| | BR-44 | Preliminary Check 4 | | | | | | | | | | | | | | |
| SYMPTOM | | | BR-50 | Diagnostic Procedure 1 | | | | | | | | | | | | |
| | Pedal vibration & noise | | BR-51 | Diagnostic Procedure 2 | | | | | | | | | | | | |
| | Warning activates | | BR-52 | Diagnostic Procedure 3 | | | | | | | | | | | | |
| | Long stopping distance | | BR-52 | Diagnostic Procedure 4 | | | | | | | | | | | | |
| | Abnormal pedal action | | BR-53 | Diagnostic Procedure 5 | | | | | | | | | | | | |
| | A.B.S. doesn't work | | BR-53 | Diagnostic Procedure 6 | | | | | | | | | | | | |
| | A.B.S. works but warning activates | | | | | | | | | | | | | | | |
| | A.B.S. works frequently | | | | | | | | | | | | | | | |
| | | | | BR-54 | L.E.D. flashing 1 - 4 | | | | | | | | | | | |
| | | | | BR-55 | L.E.D. flashing 5 - 8 | | | | | | | | | | | |
| | | | | BR-56 | L.E.D. flashing 9 | | | | | | | | | | | |
| | | | | BR-57 | L.E.D. flashing 10 | | | | | | | | | | | |
| | | | | BR-58 | L.E.D. flashing 16 | | | | | | | | | | | |
| | | | | BR-59 | L.E.D. goes off | | | | | | | | | | | |
| | | | | BR-48 | Sensor shield | ○ | | | | | | | | | | |
| | | | | BR-48 | Motor ground | | | | | | | | | | | |
| | | | BR-60 | Actuator inspection | | | | | | | | | | | | |

TROUBLE DIAGNOSES

Preliminary Check 1

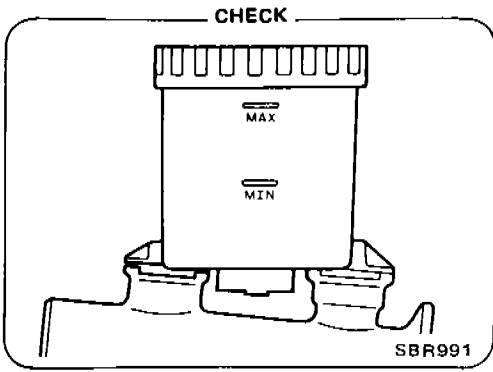

Check brake fluid level in reservoir tank.

N.G. → Fill up brake fluid.

O.K. →

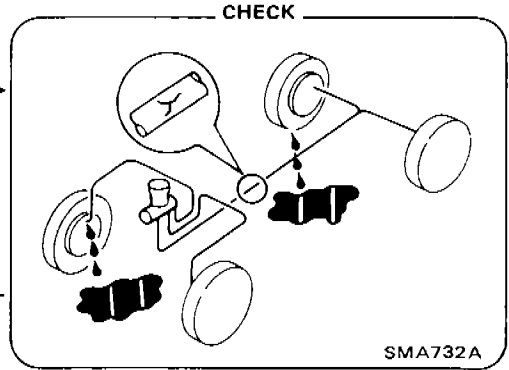

N.G. ← Repair brake system.

Check brake system.
Refer to CHECK AND ADJUSTMENT.

O.K. ↓

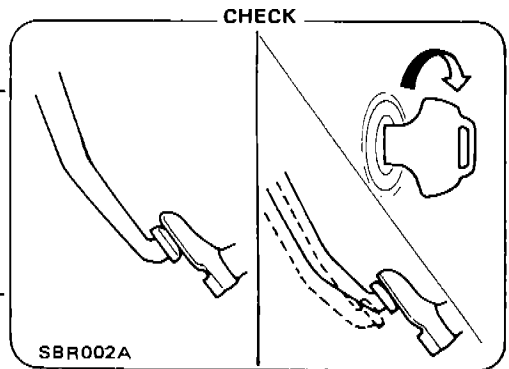

N.G. ← Repair or replace booster system.

O.K. →

Check brake booster operation and airtightness.
Refer to "Inspection" of BRAKE BOOSTER.

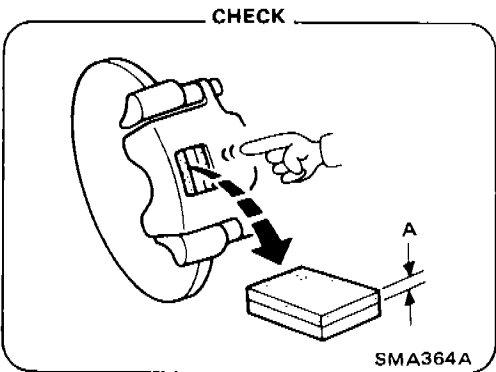

Check brake pads and rotor.
Refer to "Inspection" of FRONT and REAR DISC BRAKE.

N.G. → Replace malfunctioning parts.

TROUBLE DIAGNOSES

Preliminary Check 2

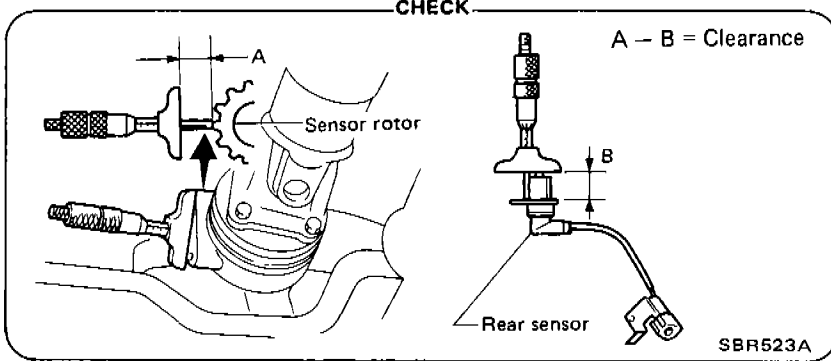
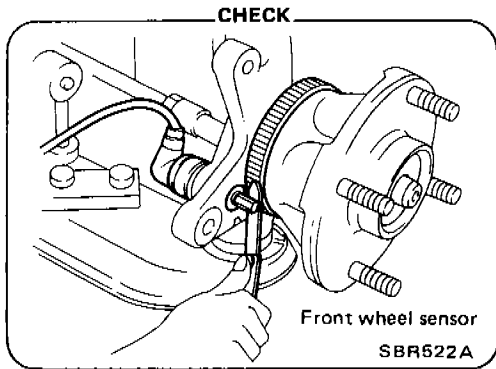

Check sensor clearance.

| | Clearance mm (in) |
|--------------------|-----------------------------------|
| Front wheel sensor | 0.275 - 0.75 (0.0108 - 0.0295) |
| Rear sensor | 0.35 - 0.625 (0.0138 - 0.0246) |

N.G.

Check sensor for the following items:

- Dust, foreign materials, etc., at fastening portion
- Improper installation
- Breakage

O.K.

N.G.

Repair or replace malfunctioning sensor.

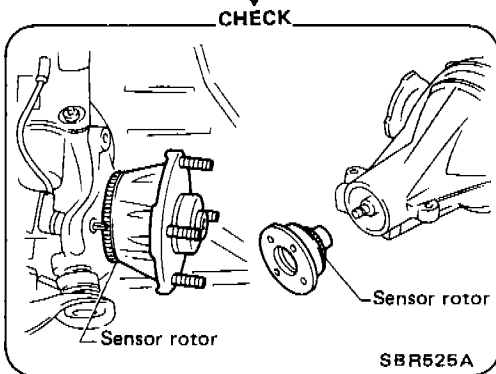

N.G.

Replace sensor rotor with wheel hub or companion flange as a set.

Check sensor rotor for teeth damage.

TROUBLE DIAGNOSES

Preliminary Check 3 CHECK

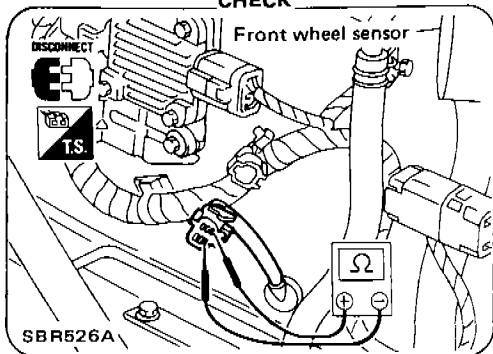

Measure each sensor resistance.
0.8 - 1.2 kΩ

N.G. → Replace.

O.K. →

Preliminary Check 3, 4

Preliminary Check 4 CHECK

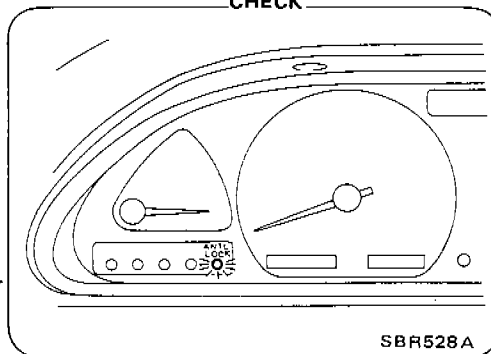

Check warning lamp activation.
When ignition switch is turned on, warning lamp turns on.

O.K. →

N.G. ↓

Check fuse.
Check bulb condition and remedy.

CHECK

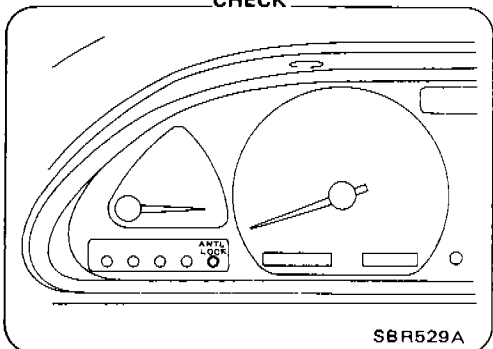

Check warning lamp for deactivation.
When engine starts, warning lamp deactivates.

O.K. ↓

DRIVE

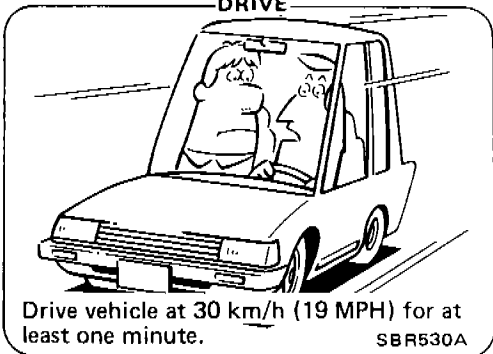

Drive vehicle at 30 km/h (19 MPH) for at least one minute.

CHECK

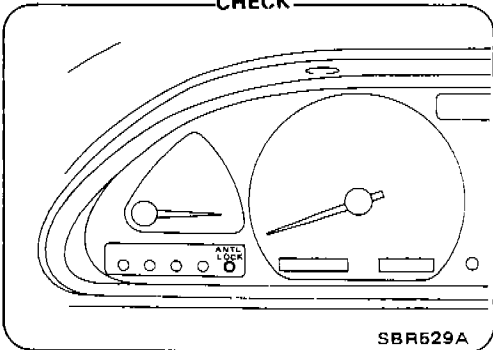

Ensure warning lamp remains off while driving.

N.G. →

CHECK

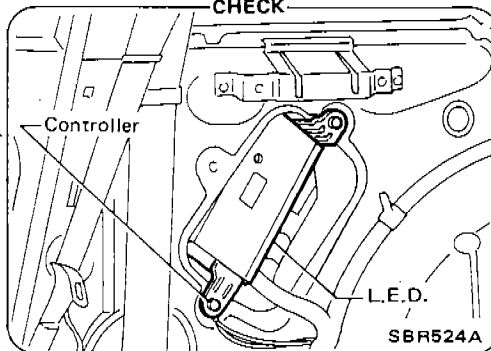

- Keep engine on and running.
- Remove rear side finisher.
R.H. model: R.H. side
L.H. model: L.H. side
- Count the number of L.E.D. flashes during 5 to 10 second "OFF" period.

Go to Self-diagnosis.
(See page BR-45.)

N.G. →

O.K. →

If Preliminary Check 2 is not performed and there is abnormal A.B.S. operation, perform Preliminary Check 2.

TROUBLE DIAGNOSES

Self-diagnosis

CHECKING THE NUMBER OF L.E.D. FLASHES

When a problem occurs in the A.B.S., the warning light on the instrument panel comes on. As shown in the Table, the control unit performs self-diagnosis.

To obtain satisfactory self-diagnosing results, the vehicle must be driven above 30 km/h (19 MPH) for at least one minute before the self-diagnosis is performed. After the vehicle is stopped, the number of L.E.D. flashes is counted while the engine is running.

The L.E.D. is located on the control unit, identifying a malfunctioning part or unit by the number of flashes. Both the warning light and the L.E.D. persistently activate, even after a malfunctioning part or unit has been repaired, unless the ignition switch is turned "OFF". After repairs, turn the ignition switch "OFF". Then start the engine and drive the vehicle over 30 km/h (19 MPH) for at least one minute to ensure that the malfunctioning part or unit has been repaired properly.

If more than two circuits malfunction at the same time, the L.E.D. will flash to indicate one of the malfunctioning circuits. After the circuit has been repaired, the L.E.D. will then flash to indicate that the other circuit is malfunctioning.

| No. of L.E.D. flashes | Malfunctioning part or unit |
|------------------------------------|-------------------------------------------------|
| 1 | Left front actuator solenoid circuit |
| 2 | Right front actuator solenoid circuit |
| 3 or 4 | Rear actuator solenoid circuit |
| 5 | Left front rotor sensor circuit |
| 6 | Right front rotor sensor circuit |
| 7 or 8 | Rear rotor sensor circuit |
| 9 | Actuator motor, motor relay circuit |
| 10 | Actuator solenoid valve relay |
| 16 | Control unit |
| Warning activates and L.E.D. "OFF" | Power supply or ground circuit for control unit |

Example

Improper operation of left front rotor sensor circuit

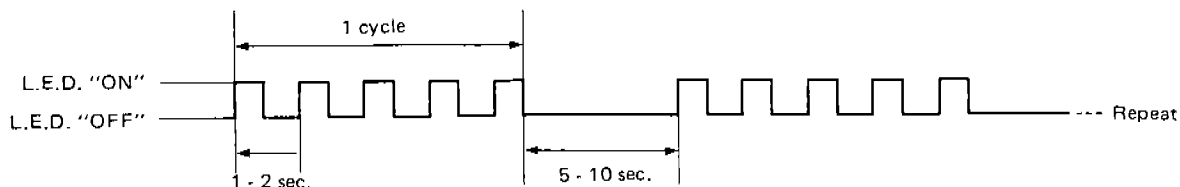

SBR531A

Go to Diagnostic Procedure from 7 to 10, where malfunction portion is concerned.

TROUBLE DIAGNOSES

Component Parts Location

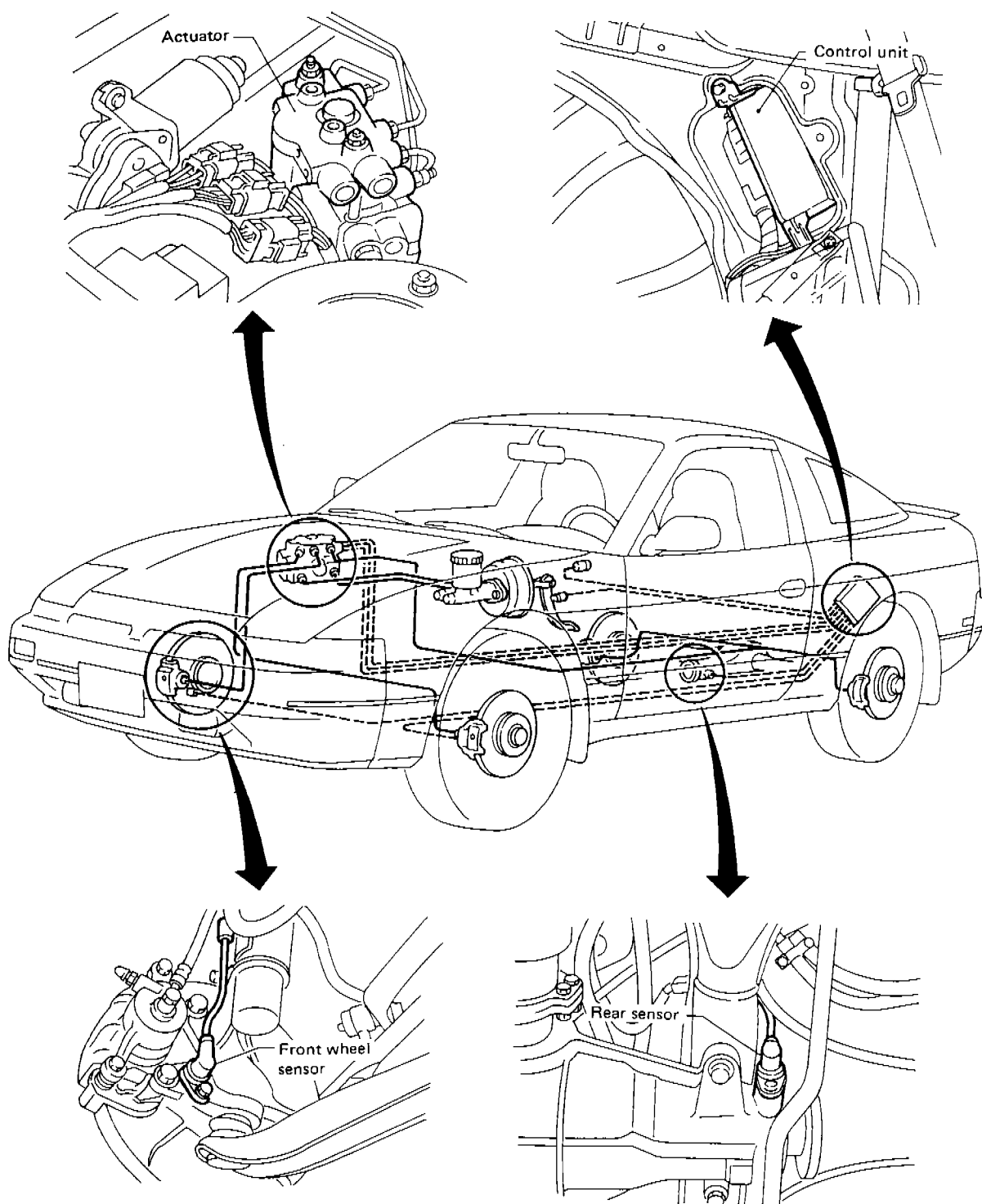

SBR532A

TROUBLE DIAGNOSES

Harness Connector Location

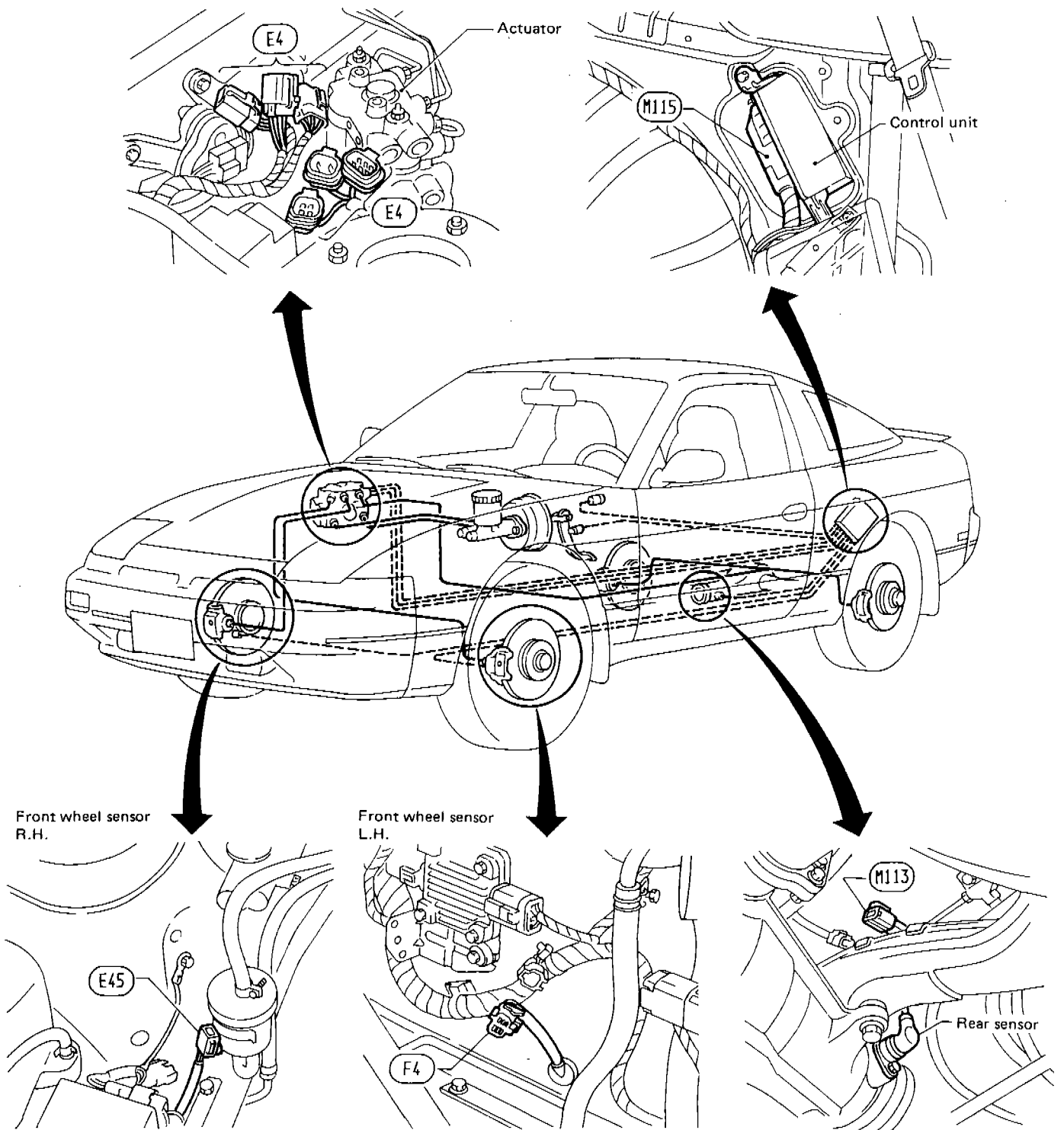

SBR533A

TROUBLE DIAGNOSES

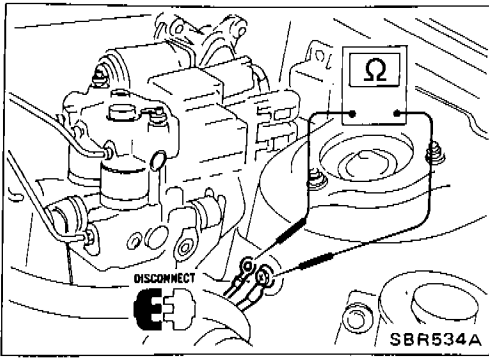

Ground Circuit Check

FRONT WHEEL SENSOR L.H. SHIELDED WIRE GROUND

- Check resistance between both terminals.
Resistance: 0Ω

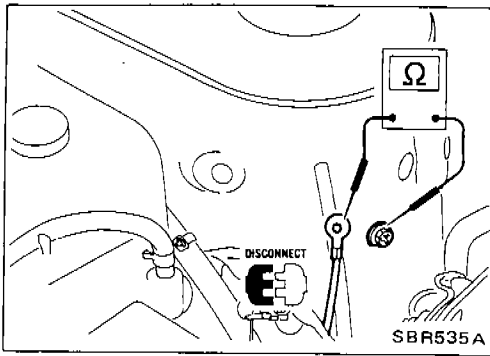

FRONT WHEEL SENSOR R.H. SHIELDED WIRE GROUND

- Check resistance between both terminals.
Resistance: 0Ω

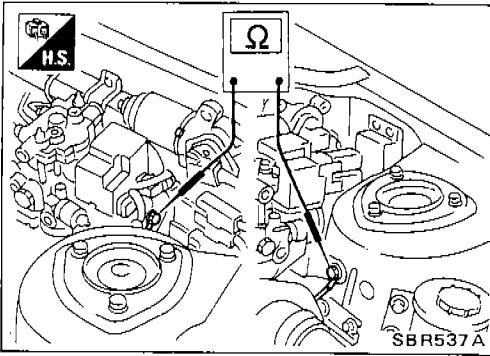

ACTUATOR MOTOR GROUND

- Check resistance between both terminals.
Resistance: 0Ω

TROUBLE DIAGNOSES

Circuit Diagram for Quick Pinpoint Check

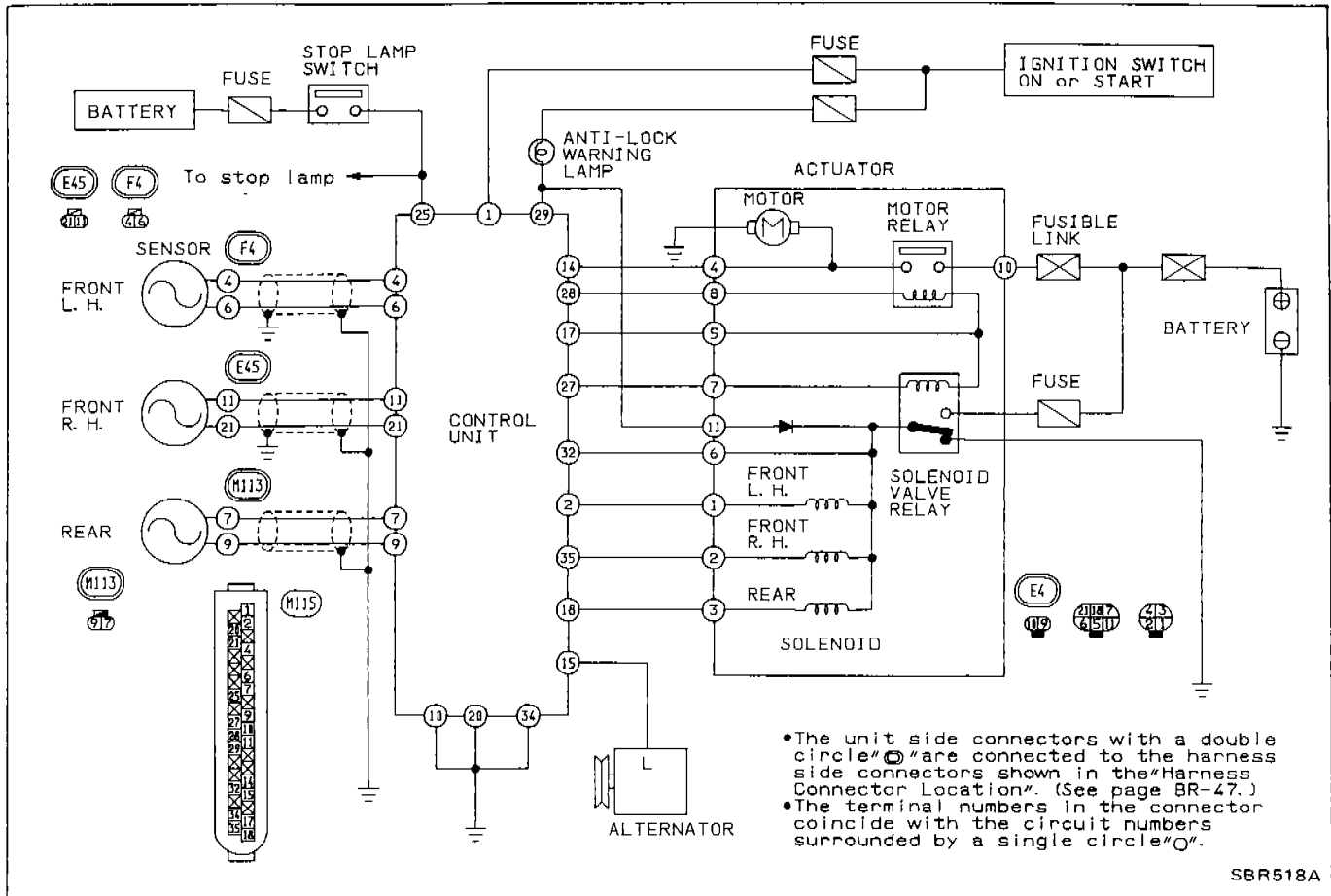

TROUBLE DIAGNOSES

Diagnostic Procedure 1

SYMPTOM: Pedal vibration and noise

Refer to worksheet results.

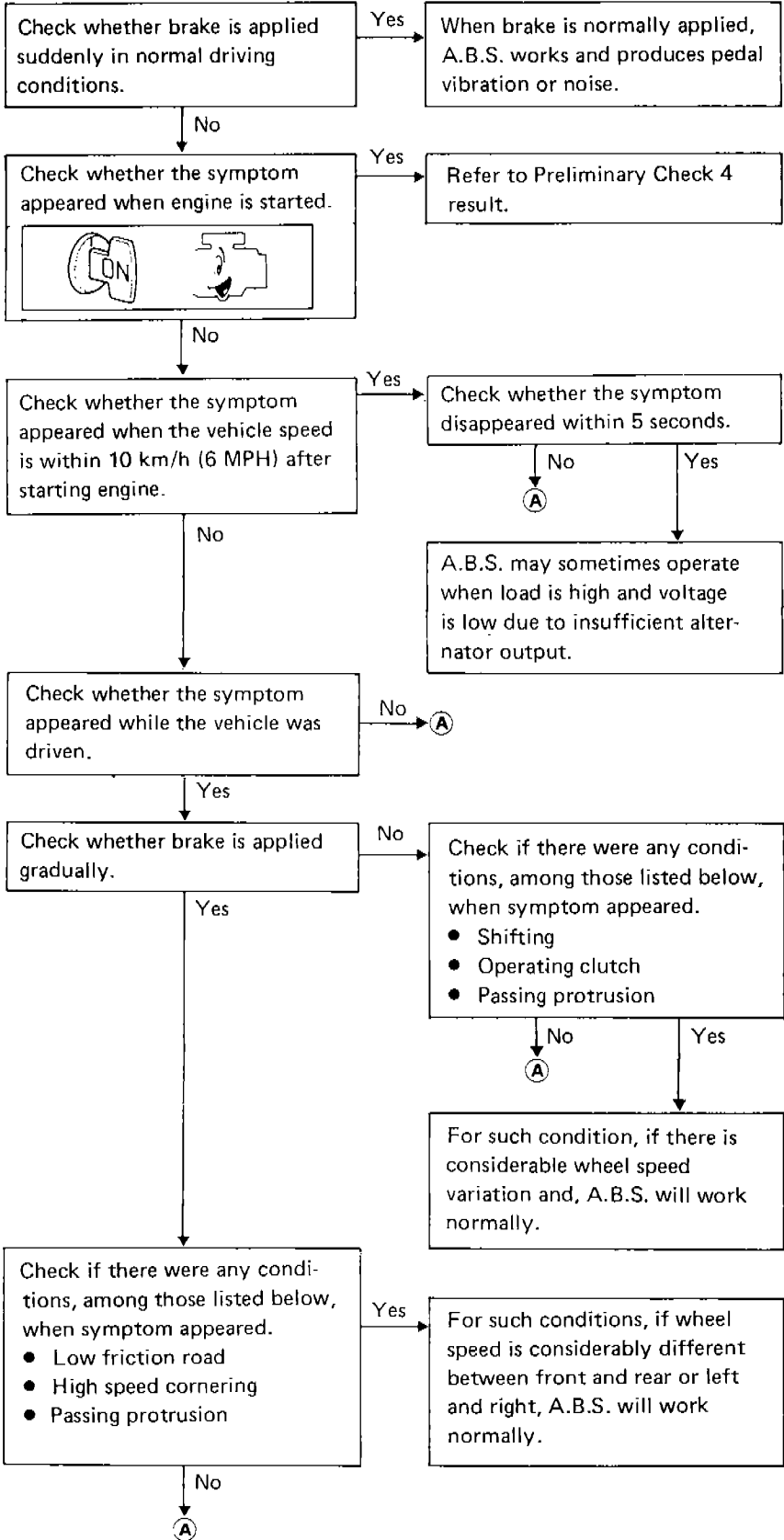
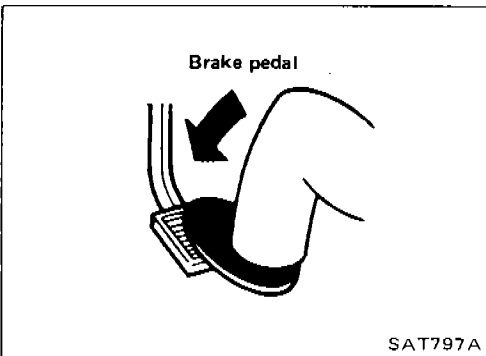
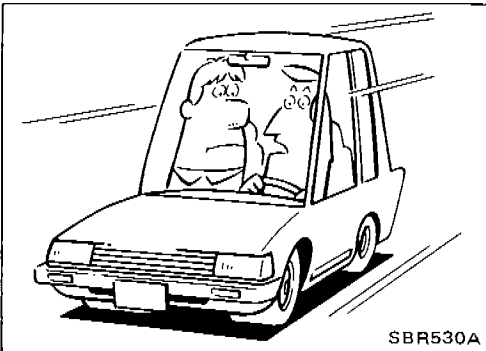
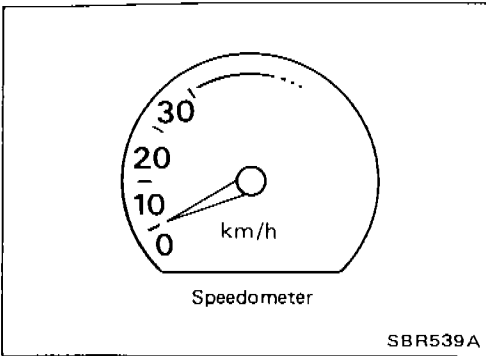
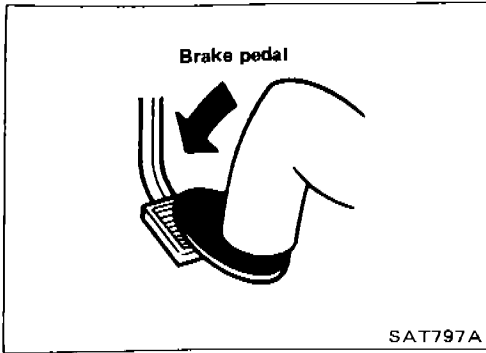

TROUBLE DIAGNOSES

Diagnostic Procedure 1 (Cont'd)

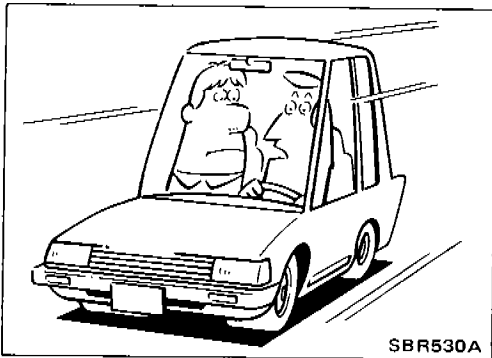
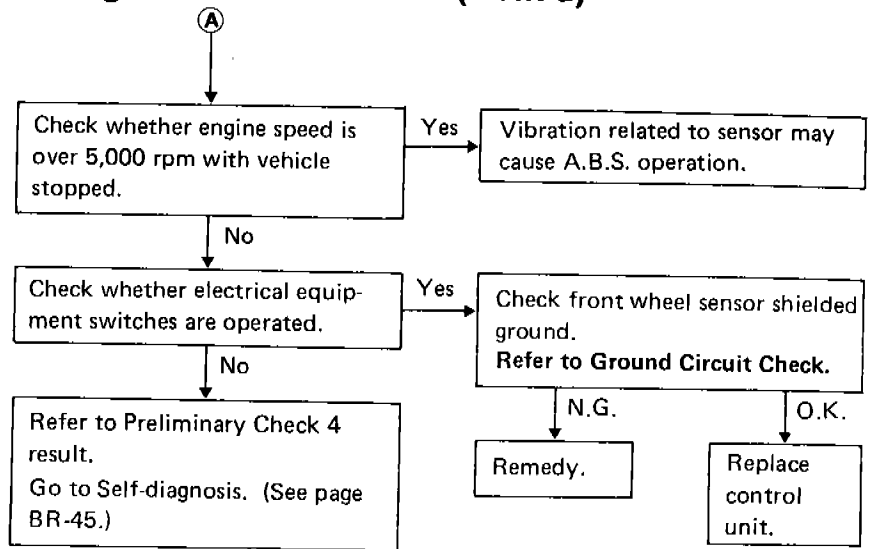

Diagnostic Procedure 2

SYMPTOM: Long stopping distance

Refer to worksheet results.

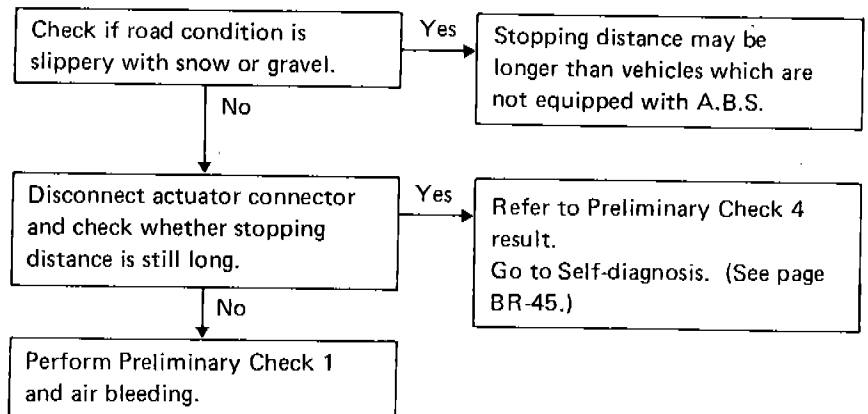

TROUBLE DIAGNOSES

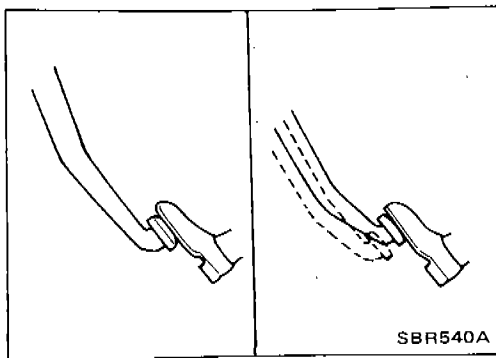

SBR540A

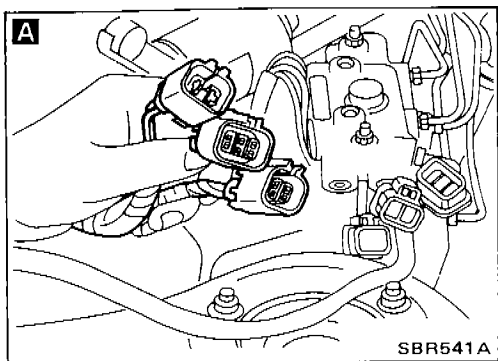

SBR541A

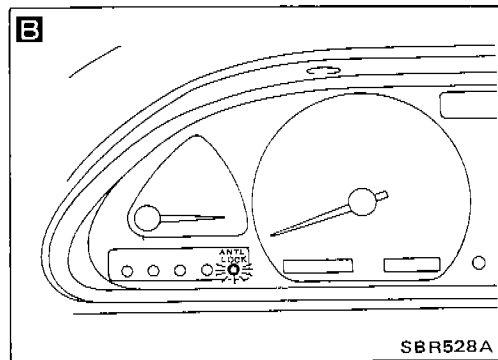

SBR528A

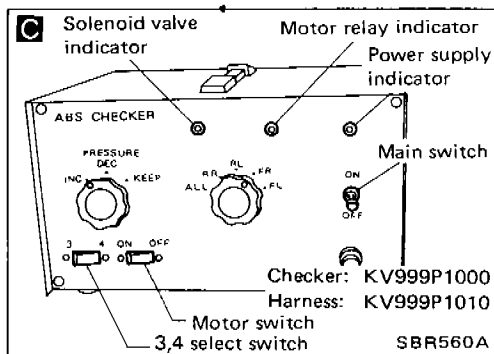

Diagnostic Procedure 3

SYMPTOM: Abnormal pedal action

Refer to worksheet results.

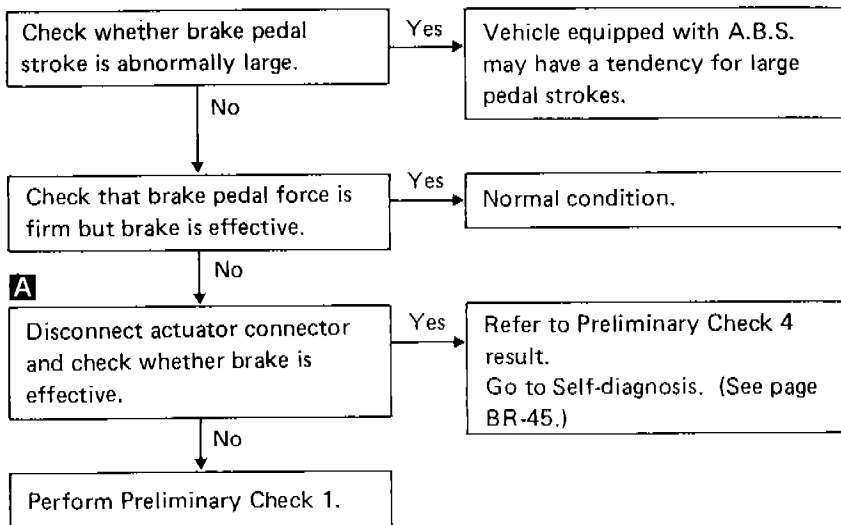

Diagnostic Procedure 4

SYMPTOM: A.B.S. doesn't work.

Refer to worksheet results.

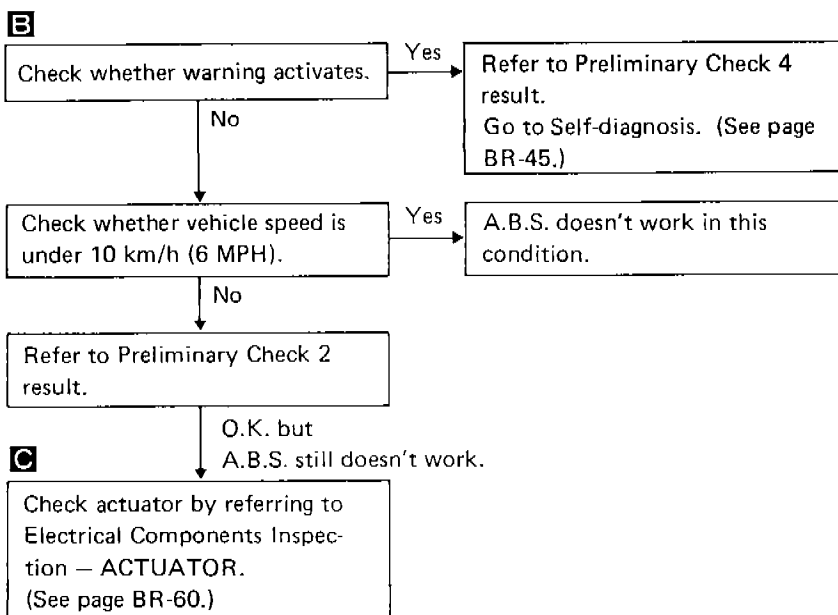

TROUBLE DIAGNOSES

Diagnostic Procedure 5

SYMPTOM: A.B.S. works but warning activates.

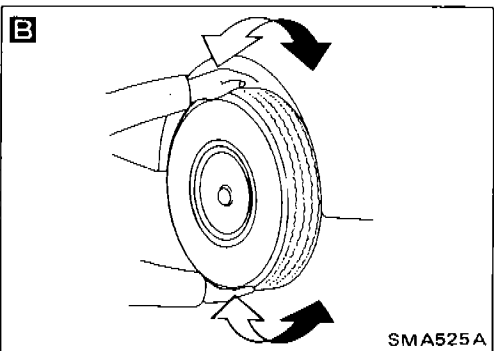
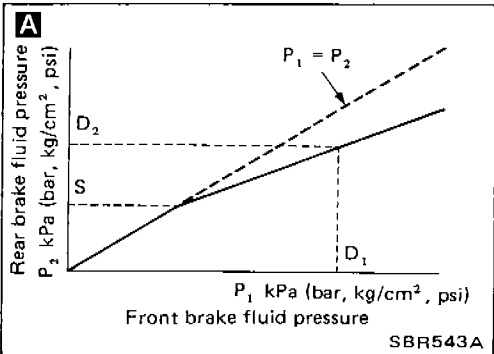
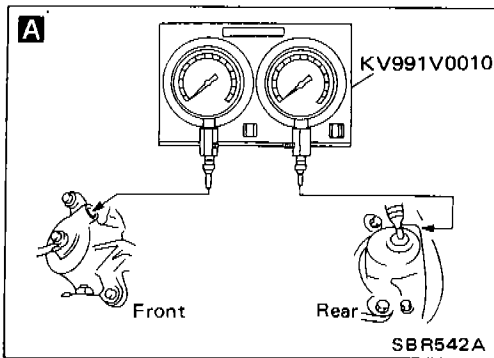
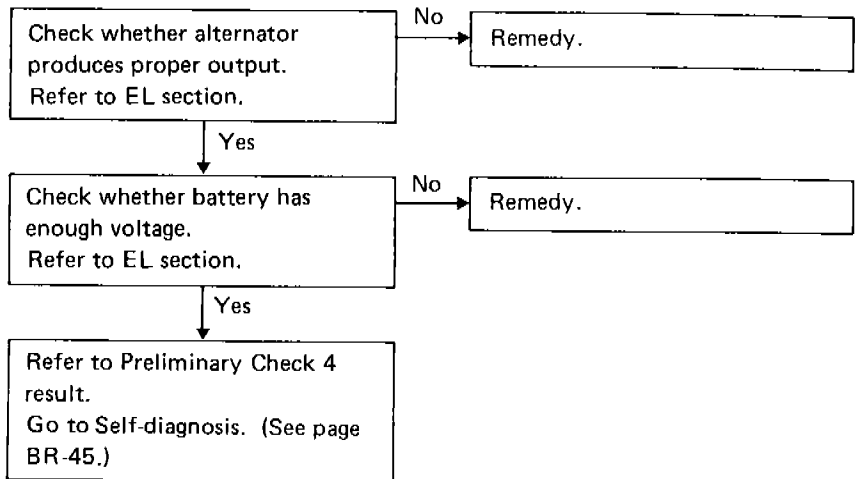

Diagnostic Procedure 6

SYMPTOM: A.B.S. works frequently.

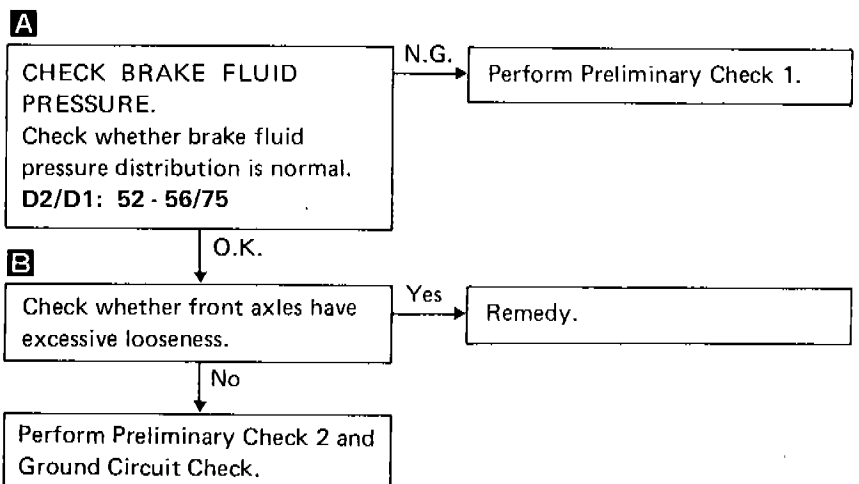

TROUBLE DIAGNOSES

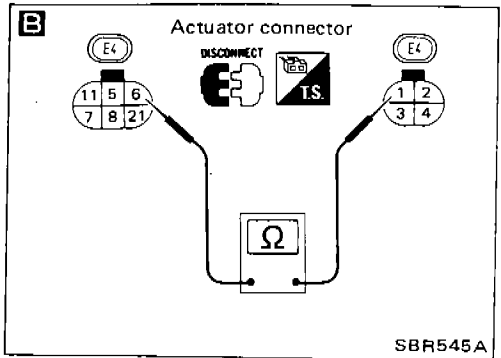
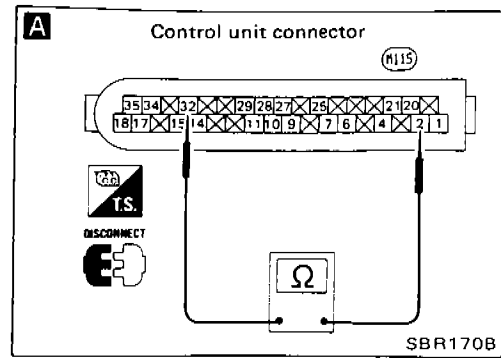

Diagnostic Procedure 7

ACTUATOR SOLENOID (L.E.D. flashing number 1 - 4)

INSPECTION START
Remove battery negative terminal connector.

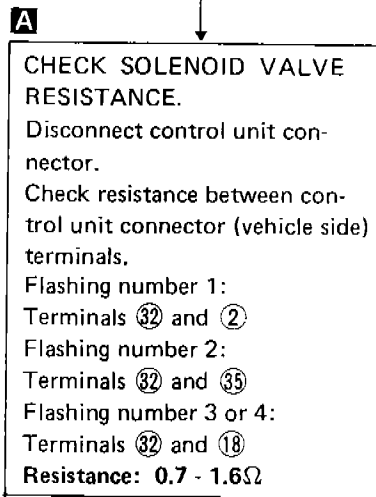

O.K.

Replace control unit.

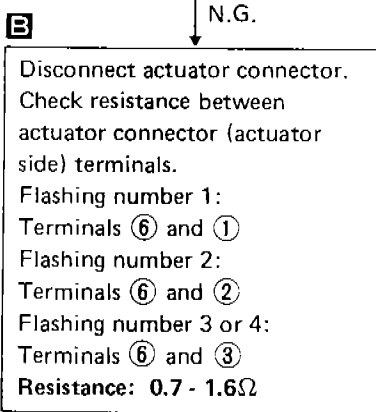

O.K.

Repair harness between actuator connector and control unit connector.

N.G.

Replace actuator.

TROUBLE DIAGNOSES

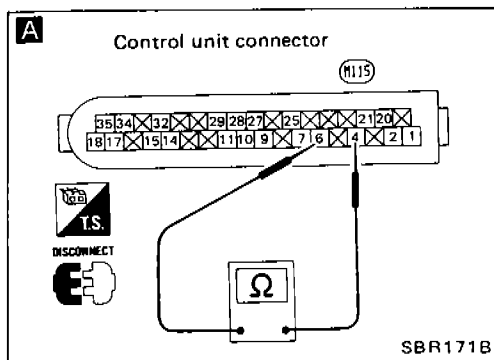

Diagnostic Procedure 8

WHEEL SPEED SENSOR (L.E.D. flashing number 5 - 8)

INSPECTION START

Remove battery negative terminal connector.

A

CHECK SPEED SENSOR RESISTANCE

Disconnect control unit connector.
Check resistance between control unit connector (vehicle side) terminals.

Flashing number 5:

Terminals ④ and ⑥

Flashing number 6:

Terminals ⑪ and ⑫

Flashing number 7 or 8:

Terminals ⑦ and ⑨

Resistance: 0.8 - 1.2 kΩ

O.K.

Replace control unit.

N.G.

Refer to Preliminary Check 3 result.

Check whether sensor has 0.8 - 1.2 kΩ resistance.

N.G.

Replace sensor.

O.K.

Repair harness between sensor connector and control unit connector.

TROUBLE DIAGNOSES

Diagnostic Procedure 9

ACTUATOR MOTOR RELAY (L.E.D. flashing number 9)

INSPECTION START
Remove battery negative terminal connector.

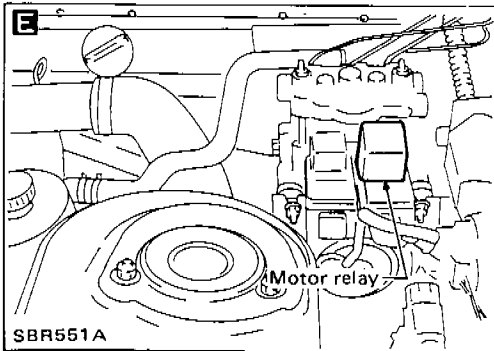
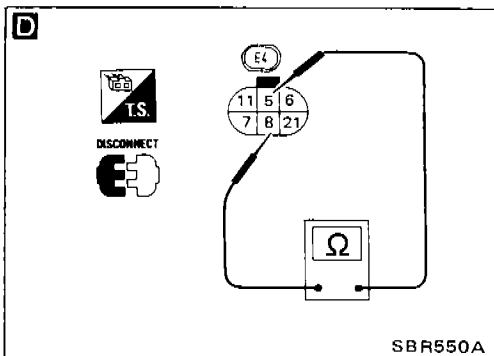
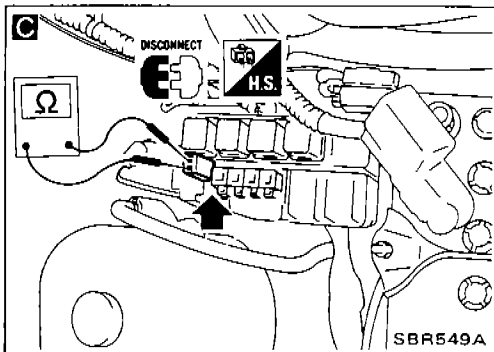
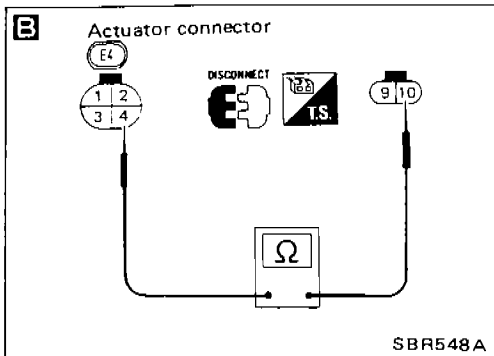
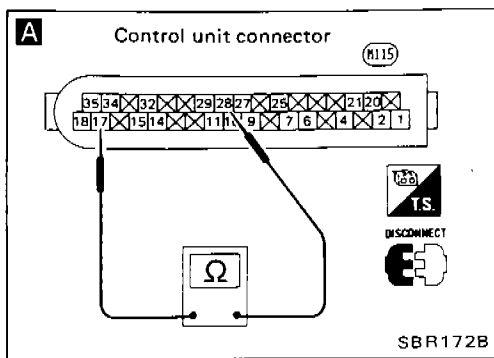

A
CHECK MOTOR RELAY SOLENOID RESISTANCE.
Disconnect control unit connector.
Check resistance between control unit connector (vehicle side) terminals ⑰ and ⑳.
Resistance: 38 - 45Ω

B
CHECK MOTOR RELAY DEACTIVATION.
Disconnect actuator connector.
Check continuity between actuator connector (actuator side) terminals ④ and ⑩.

E
Replace motor relay.

C
Check if motor's fusible link is blown.
Resistance:
Approximately 0Ω

E
Replace fusible link.

D
Disconnect actuator connector.
Check resistance between actuator connector (actuator side) terminals ⑧ and ⑤.
Resistance: 38 - 45Ω

O.K.
Repair harness between actuator and control unit.

E
N.G.
Replace motor relay.

No
Perform Electrical Components Inspection - ACTUATOR.
(See page BR-60.)

O.K.
Replace control unit.

N.G.
Replace actuator.

TROUBLE DIAGNOSES

Diagnostic Procedure 10

ACTUATOR SOLENOID VALVE RELAY (L.E.D. flashing number 10)

INSPECTION START
Remove battery negative terminal connector.

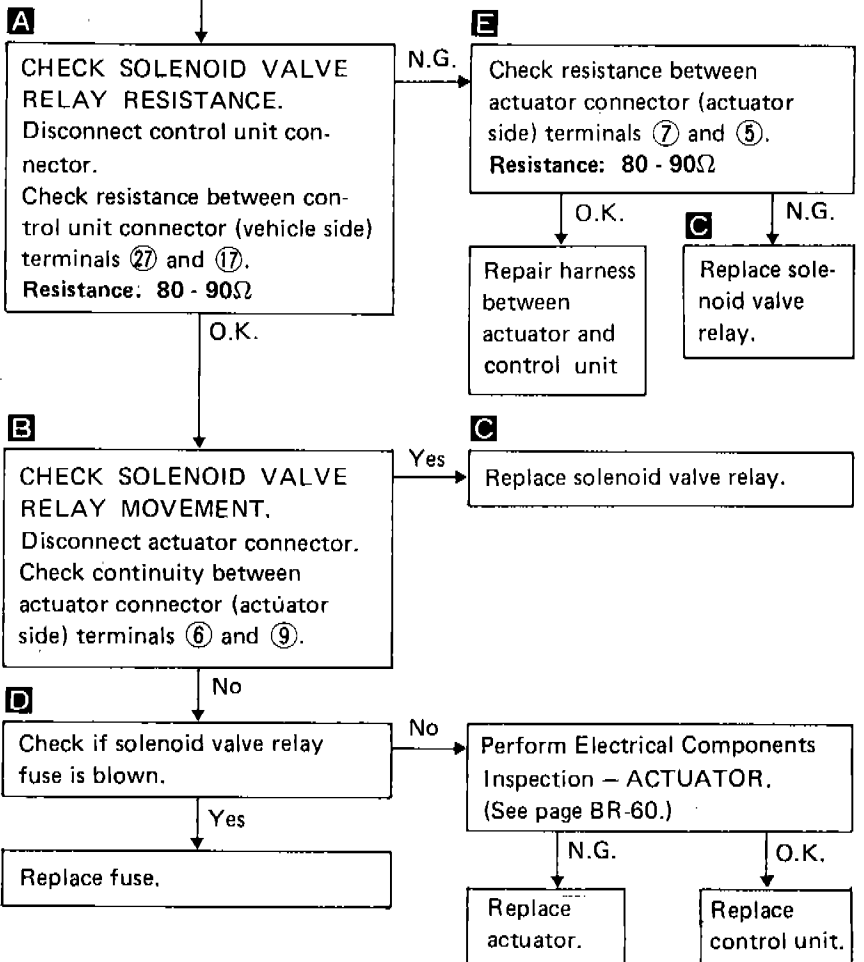
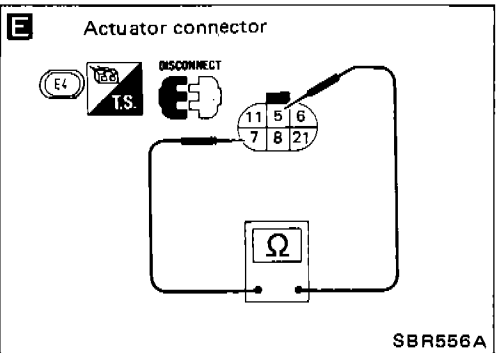
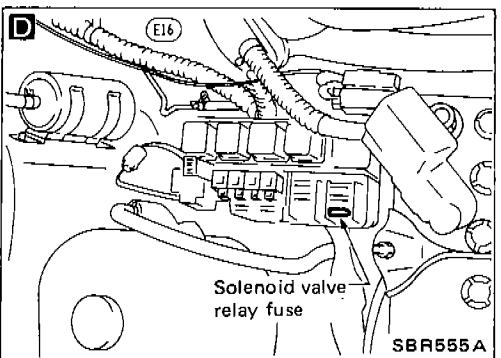
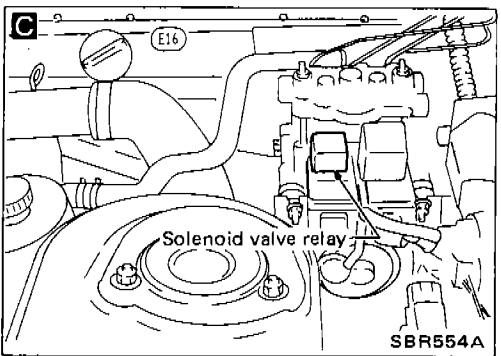
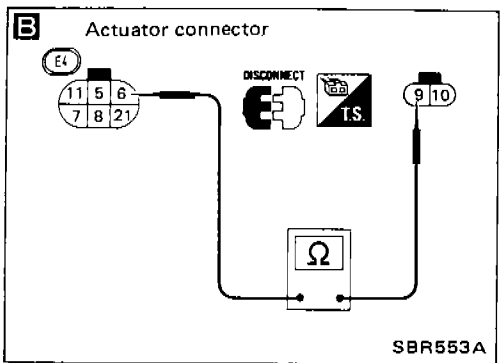
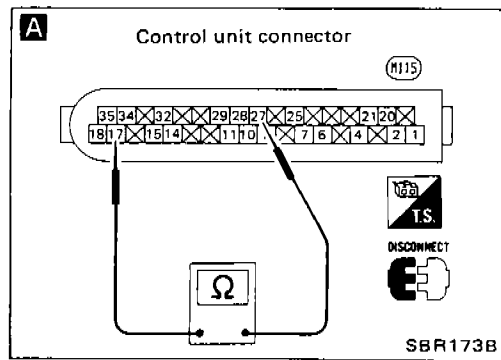

TROUBLE DIAGNOSES

Diagnostic Procedure 11

CONTROL UNIT (L.E.D. flashing number 16)

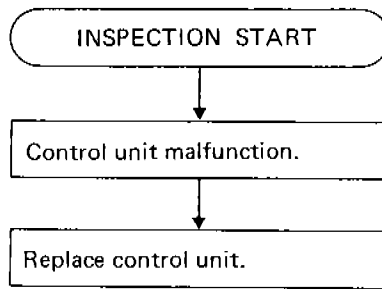

TROUBLE DIAGNOSES

Diagnostic Procedure 12

CONTROL UNIT OR POWER SUPPLY AND GROUND CIRCUIT (Warning activates but L.E.D. comes off.)

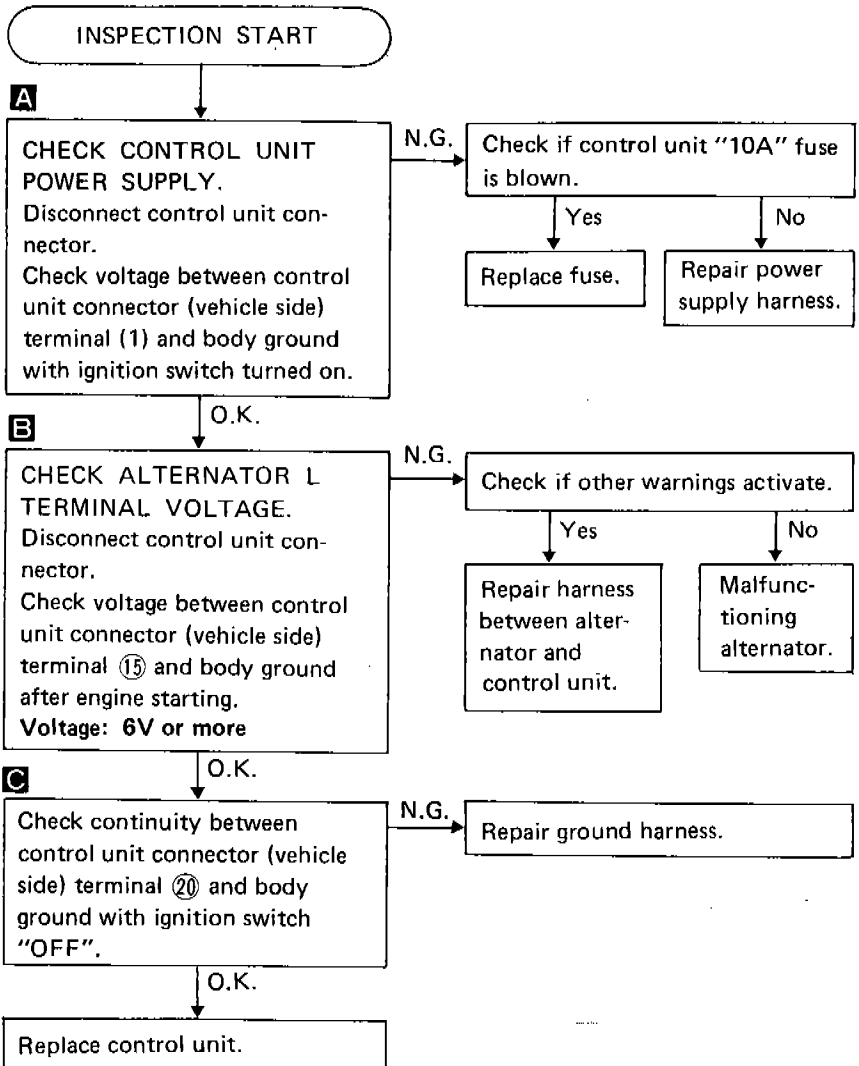
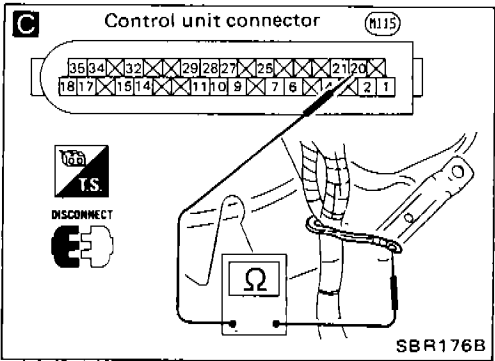
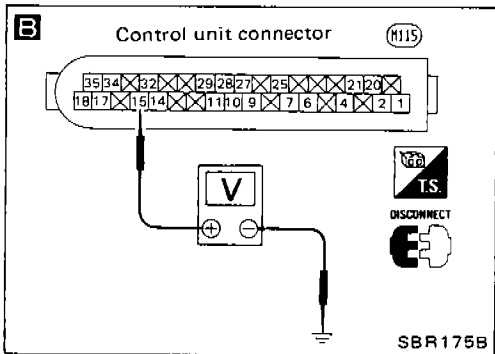
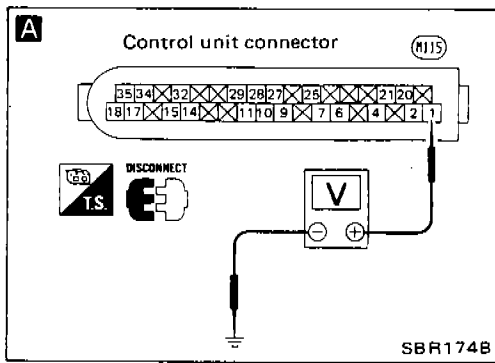

TROUBLE DIAGNOSES

Electrical Components Inspection ACTUATOR (Not self-diagnostic item)

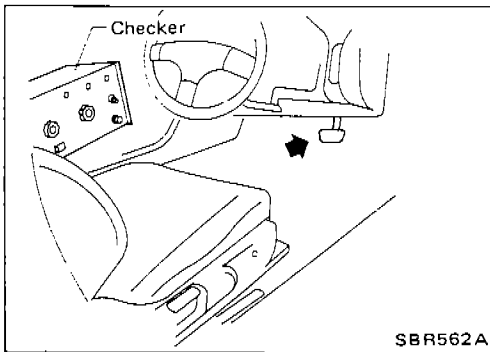
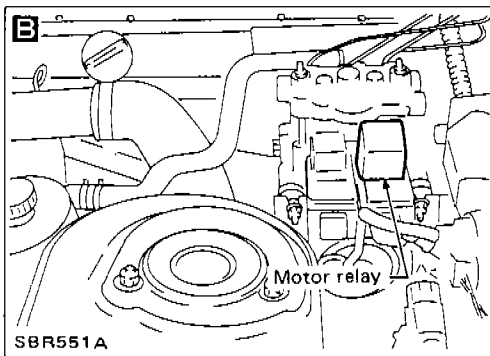
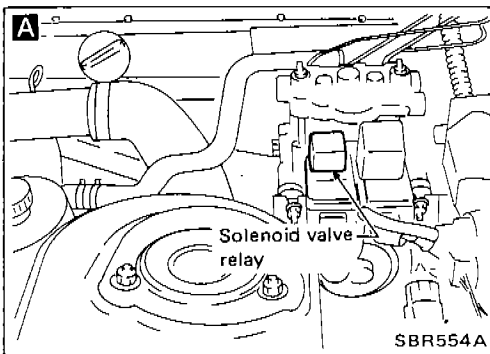
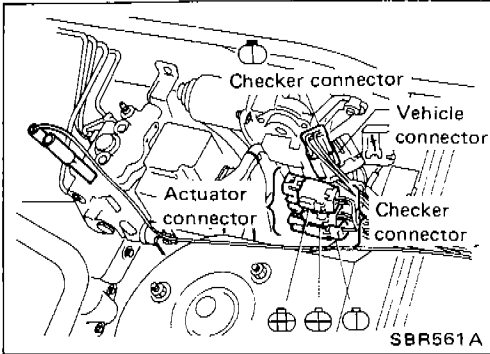
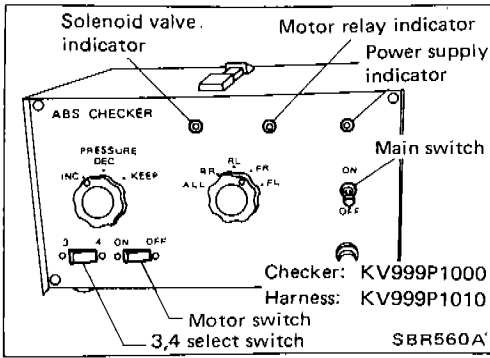

INSPECTION START

Connect A.B.S. checker to actuator connector and vehicle harness with battery terminal connected and all checker switch turning off.
Use harness for 3 channel.
Set select switch to 3 channel.

Turn checker power supply switch on.
Check power supply indicator for coming on.

No → Replace battery with fully charged new one, if checker connection is correct.

Yes → Check checker valve relay indicator for coming on.

No → **A** Replace solenoid valve relay, if checker connection is correct.

Yes → Select one valve.
Select pressure decreasing position by switch then turn motor switch on.
Turn motor switch off.
Select pressure increasing position.

Repeat so that all valve will be performed.

CAUTION:
Do not hold switch at the pressure decreasing position for more than 5 seconds. Otherwise, solenoid valve may be overheated and damaged.

Check motor relay indicator for coming on while motor switch is turned on.

No → **B** Replace motor relay, if checker connection is correct.

Yes → Check motor for operational sound beside the actuator in a quiet place.

No → Replace actuator as assembly, if Diagnostic Procedures 7 - 12 are already performed and checker connection is correct.

Yes → Bring checker in the vehicle and depress the brake pedal.
Repeat step **A**.

Valve select switch position RR is used for 4 channel checking. In the case of 3 channels, brake pedal vibration or depression will not occur in position RR. It will occur, however, in position RL.

A

TROUBLE DIAGNOSES

Electrical Components Inspection (Cont'd)

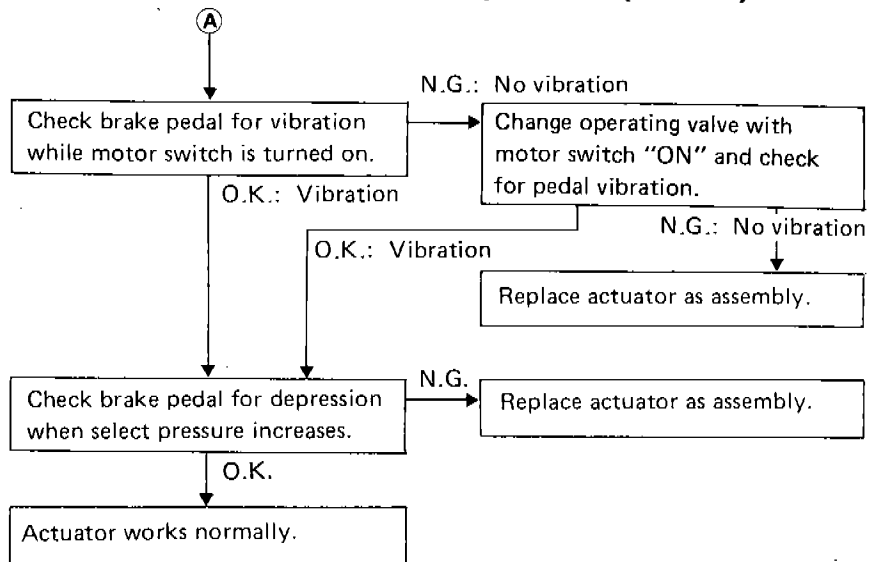

SERVICE DATA AND SPECIFICATIONS (S.D.S.)

General Specifications

| Destination | Except Europe | Europe (Without A.B.S.*) | Europe (With A.B.S.*) |
|---------------------------------------------------------------------|-----------------------------------------------|--------------------------------------------|-----------------------|
| Front brake | | | |
| Brake model | CL18VB | CL25VA | |
| Cylinder bore diameter mm (in) | 48.1 (1.894) | 57.2 (2.252) | |
| Pad length x width x thickness mm (in) | 100.8 x 44.3 x 10.0 (3.97 x 1.744 x 0.394) | 134.1 x 45.3 x 11.0 (5.28 x 1.783 x 0.433) | |
| Rotor outer diameter x thickness mm (in) | 250 x 18 (9.84 x 0.71) | 257 x 22 (10.12 x 0.87) | |
| Rear brake | | | |
| Brake model | CL9H | AD9 | |
| Cylinder bore diameter mm (in) | 33.96 (1.3370) | 34.93 (1.3752) | |
| Pad length x width x thickness mm (in) | 75.0 x 40.0 x 9.5 (2.953 x 1.575 x 0.374) | 93.8 x 33.4 x 10.0 (3.693 x 1.315 x 0.394) | |
| Rotor outer diameter x thickness mm (in) | 258 x 9 (10.16 x 0.35) | 266 x 9 (10.47 x 0.35) | |
| Master cylinder | | | |
| Cylinder bore diameter mm (in) | 20.64 (13/16) | 22.22 (7/8) | 23.81 (15/16) |
| Control valve | | | |
| Valve model | Proportioning valve (within master cylinder) | | |
| Sprit point x reducing ratio kPa (bar, kg/cm ² , psi) | 3,923 (39.2, 40, 569) x 0.4 | | |
| Brake booster | | | |
| Booster model | M23, G23 | M195T | |
| Diaphragm diameter mm (in) | 230 (9.06) | Primary 205 (8.07) Secondary 180 (7.09) | |
| Brake fluid | | | |
| Recommended brake fluid | DOT 3 | | |
| Parking brake | | | |
| Control type | Center lever | | |
| Parking drum brake | | | |
| Brake model | — | DS17HD | |
| Lining Width x thickness x length mm (in) | — | 154.1 x 25.0 x 3.0 (6.07 x 0.984 x 0.118) | |
| Drum inner diameter mm (in) | — | 172.0 (6.77) | |

*Anti-lock Braking System

SERVICE DATA AND SPECIFICATIONS (S.D.S.)

Inspection and Adjustment

FRONT DISC BRAKE

Unit: mm (in)

| Brake model | CL18VB | CL25VA |
|-----------------------------------------|---------------|--------------|
| Item | | |
| Pad wear limit Minimum thickness | 2.0 (0.079) | |
| Rotor repair limit Minimum thickness | 16.0 (0.630) | 20.0 (0.787) |
| Maximum runout | 0.07 (0.0028) | |

REAR DISC BRAKE

Unit: mm (in)

| Brake model | CL9H | AD9 |
|-----------------------------------------|---------------|-----|
| Item | | |
| Pad wear limit Minimum thickness | 2.0 (0.079) | |
| Rotor repair limit Minimum thickness | 8.0 (0.315) | |
| Maximum runout | 0.07 (0.0028) | |

PARKING DRUM BRAKE

Unit: mm (in)

| Brake model | DS17H |
|-----------------------------------------------|--------------|
| Lining replacement limit Minimum thickness | 1.5 (0.059) |
| Drum repair limit Maximum inner diameter | 173.0 (6.81) |

BRAKE PEDAL

Unit: mm (in)

| Model | L.H.D. | R.H.D. |
|----------------------------------------------------------------------------------------------------|--------------------------------|--------------------------------|
| Free height | | |
| M/T | 177.0 - 187.0 (6.97 - 7.36) | 178.0 - 188.0 (7.01 - 7.40) |
| A/T | 186.0 - 196.0 (7.32 - 7.72) | 188.0 - 198.0 (7.40 - 7.80) |
| Depressed height [under force of 490 N (50 kg, 110 lb) with engine running] Except Europe | | |
| M/T | 90 (3.54) or more | 95 (3.74) or more |
| A/T | 100 (3.94) or more | 100 (3.94) or more |
| Europe | | |
| M/T | 85 (3.35) or more | 90 (3.54) or more |
| A/T | 95 (3.74) or more | 95 (3.74) or more |
| Clearance between pedal stopper and threaded end of stop lamp switch | 0.3 - 1.0 (0.012 - 0.039) | |
| Clearance between pedal stopper and threaded end of A.S.C.D. switch | 0.3 - 1.0 (0.012 - 0.039) | |
| Pedal free play at clevis | 1 - 3 (0.04 - 0.12) | |

PARKING BRAKE

| Control type | Center lever |
|---------------------------------------------------------------|--------------|
| Item | |
| Number of notches [under force of 196 N (20 kg, 44 lb)] | 6 - 8 |
| Number of notches (when warning switch comes on) | 1 |



STEERING SYSTEM

SECTION **ST**

CONTENTS

| | |
|-----------------------------------------------------------------|-------|
| PRECAUTIONS | ST- 2 |
| PREPARATION | ST- 3 |
| ON-VEHICLE INSPECTION | ST- 5 |
| ON-VEHICLE INSPECTION (Power steering) | ST- 7 |
| STEERING WHEEL AND STEERING COLUMN | ST-10 |
| POWER STEERING GEAR AND LINKAGE (Model PR24SC and PR26SC) | ST-15 |
| POWER STEERING OIL PUMP | ST-28 |
| SERVICE DATA AND SPECIFICATIONS (S.D.S.) | ST-32 |

ST

PRECAUTIONS

- Before disassembly, thoroughly clean the outside of the unit.
- Disassembly should be done in a clean work area. It is important to prevent the internal parts from becoming contaminated by dirt or other foreign matter.
- When disassembling parts, be sure to place them in order in a parts rack so they can be reinstalled in their proper positions.
- Use nylon cloths or paper towels to clean the parts; common shop rags can leave lint that might interfere with their operation.
- Before inspection or reassembly, carefully clean all parts with a general purpose, non-flammable solvent.
- Before assembly, apply a coat of recommended A.T.F.* to hydraulic parts. Vaseline may be applied to O-rings and seals. Do not use any grease.
- Replace all gaskets, seals and O-rings. Avoid damaging O-rings, seals and gaskets during installation. Perform functional tests whenever designated.

*: Automatic transmission fluid

PREPARATION

SPECIAL SERVICE TOOLS

*: Special tool or commercial equivalent

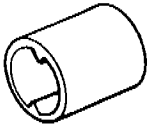
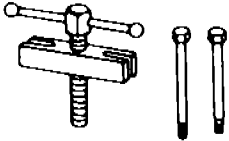
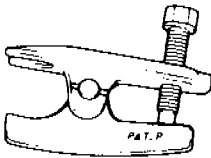
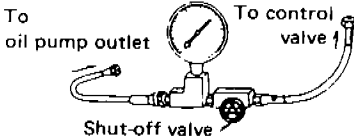
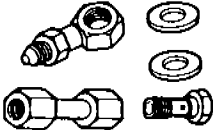
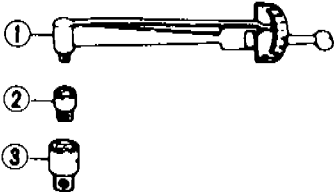
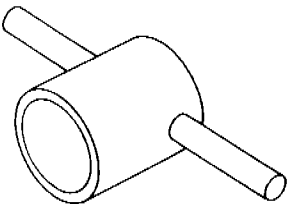
| Tool number Tool name | Description | Measuring pinion rotating torque |
|------------------------------------------------------------------------------------------------------------------|--------------------------------------------------------------------------------------|----------------------------------------|
| KV48100700 Torque adapter |  | |
| ST27180001* Steering wheel puller |  | Removing and installing steering wheel |
| HT72520000* Ball joint remover |  | Removing ball joint |
| ST27091000* Pressure gauge |  | Measuring oil pressure |
| KV48102500 Pressure gauge adapter |  | Measuring oil pressure |
| ST3127S000* ① GG91030000 Torque wrench ② HT62940000 Socket adapter ③ HT62900000 Socket adapter |  | Measuring turning torque |
| KV48104400 Rack seal ring reformer |  | Reforming teflon ring |

PREPARATION

COMMERCIAL SERVICE TOOLS

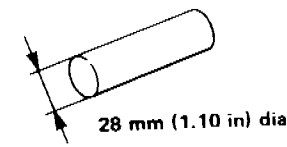
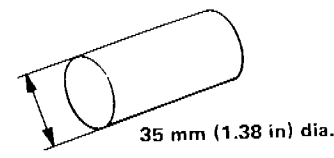
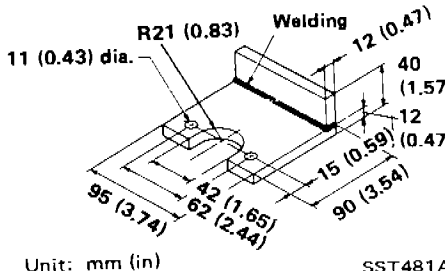
| Tool name | Description |
|-----------------------|--------------------------------------------------------------------------------------------------------------------------------------------------------------------------------------------------------------------------------------------------------|
| Rear oil seal drift |  <p style="text-align: center;">28 mm (1.10 in) dia.</p> <p style="text-align: right;">Installing rear oil seal</p> |
| Pinion oil seal drift |  <p style="text-align: center;">35 mm (1.38 in) dia.</p> <p style="text-align: right;">Installing pinion oil seal</p> |
| Oil pump attachment |  <p style="text-align: center;">Unit: mm (in) SST481A</p> <p style="text-align: right;">Disassembling and assembling oil pump</p> |

ON-VEHICLE INSPECTION

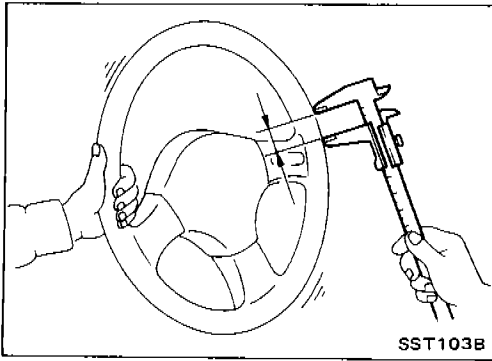

Checking Steering Wheel Play

- With wheels in a straight-ahead position, check steering wheel play.

Steering wheel play:

35 mm (1.38 in) or less

- If it is not within specification, check rack and pinion assembly.

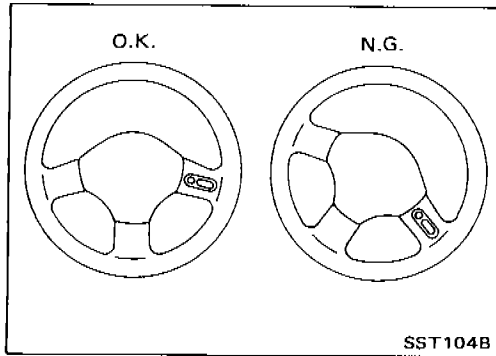

Checking Neutral Position on Steering Wheel

Pre-checking

- Verify that the steering gear is centered before removing the steering wheel.

Checking

- Check that the steering wheel is in the neutral position when driving straight ahead.
- If it is not in the neutral position, remove the steering wheel and reinstall it correctly.
- If the neutral position is between two serrated teeth, loosen tie-rod lock nut and move tie-rod in the opposite direction by the same amount on both left and right sides to compensate for error in the neutral position.

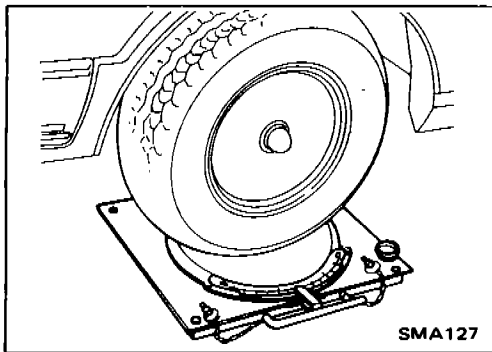

Front Wheel Turning Angle

- Rotate steering wheel all the way right and left; measure turning angle.

Turning angle of full turns:

Refer to section FA for S.D.S.

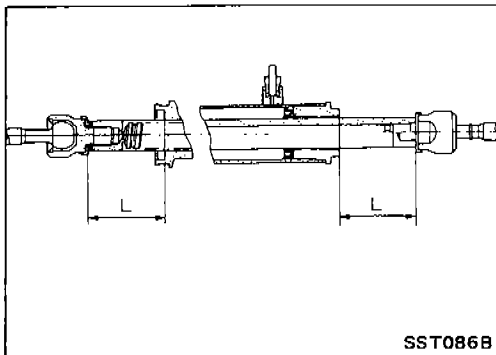

- If it is not within specification, check rack stroke.

Measured length "L":

Refer to S.D.S.

ON-VEHICLE INSPECTION

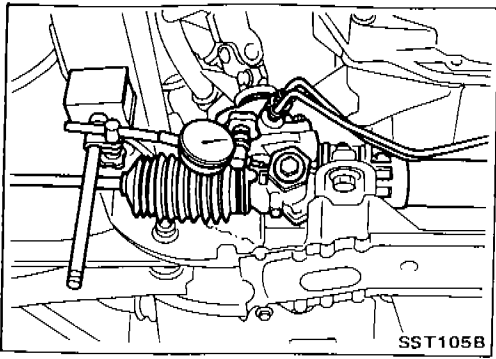

Checking Gear Housing Movement

- Check the movement of steering gear housing during stationary steering. The maximum allowable movement is as follows:

Movement of gear housing:

± 2 mm (± 0.08 in) (on dry paved surface) or less

Apply a force of 49 N (5 kg, 11 lb) to steering wheel to check the gear housing movement.

On models equipped with power steering, turn off ignition key while checking.

- If movement exceeds the limit, replace mount insulator after confirming proper installation of gear housing clamps.

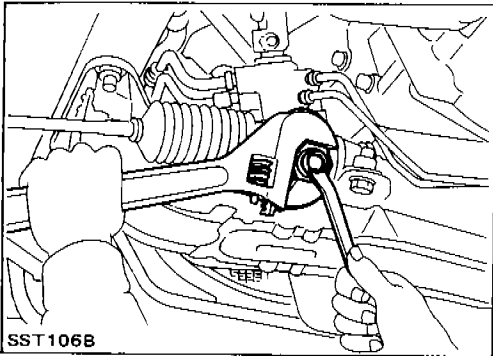

Adjusting Rack Retainer

- Perform this driving test on a flat road.
1. Check whether vehicle moves in a straight line when steering wheel is released.
 2. Check whether steering wheel returns to neutral position when steering wheel is released from a slightly turned (approx. 20°) position.
- If any abnormality is found, correct it by resetting adjusting screw.

Checking and Adjusting Drive Belts

Refer to section MA for Drive Belt Inspection.

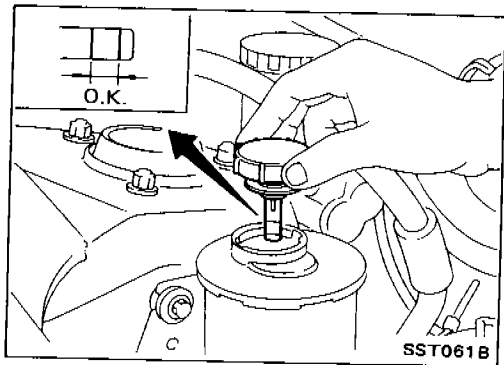

Checking Fluid Level

Check the level when the fluid is cold.

CAUTION:

- Do not overfill.
- Recommended fluid is Automatic Transmission Fluid "DEXRON™ Type".

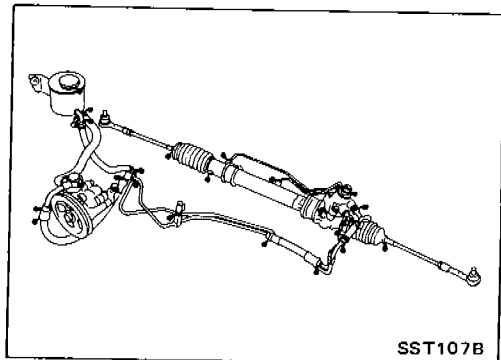

Checking Fluid Leakage

Check the lines for improper attachment and for leaks, cracks, damage, loose connections, chafing or deterioration.

1. Run engine at idle speed or 1,000 rpm.
Make sure temperature of fluid in oil tank rises to 60 to 80°C (140 to 176°F).
2. Turn steering wheel right-to-left several times.
3. Hold steering wheel at each "lock" position for five seconds and carefully check for fluid leakage.

CAUTION:

Do not hold the steering wheel in a locked position for more than 15 seconds.

4. If fluid leakage at connectors is noticed, loosen flare nut and then retighten.

Do not overtighten connector as this can damage O-ring, washer and connector.

Bleeding Hydraulic System

1. Raise front end of vehicle until wheels clear ground.
2. Add fluid into oil tank to specified level. Meanwhile, quickly turn steering wheel fully to right and left and lightly touch steering stoppers.
Repeat steering wheel operation until fluid level no longer decreases.
3. Start engine.
Repeat step 2 above.
- Incomplete air bleeding will cause the following to occur.
When this happens, bleed air again.

ON-VEHICLE INSPECTION (Power steering)

Bleeding Hydraulic System (Cont'd)

- Generation of air bubbles in reservoir tank
- Generation of clicking noise in oil pump
- Excessive buzzing in oil pump

While the vehicle is stationary or while turning the steering wheel slowly, fluid noise may occur in the valve or oil pump. This noise is inherent in this steering system, and it will not affect performance or durability of the system.

Checking Steering Wheel Turning Force

- Park vehicle on a level, dry surface and set parking brake.
- Start engine.
- Warm up power steering fluid to adequate operating temperature.

Temperature of fluid:

Approximately 60 - 80°C (140 - 176°F).

Tires need to be inflated to normal pressure.

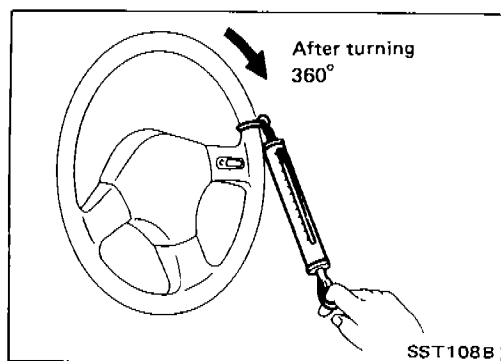

- Check steering wheel turning force with engine idling when steering wheel has been turned 360° from neutral position.

Steering wheel turning force:

39 N (4 kg, 9 lb) or less

Checking Hydraulic System

Before starting, check belt tension, driving pulley and tire pressure.

- Set Tool. Open shut-off valve. Then bleed air. (See "Bleeding Hydraulic System".)
- Run engine.

Make sure temperature of fluid in tank rises to 60 to 80°C (140 to 176°F).

ON-VEHICLE INSPECTION (Power steering)

Checking Hydraulic System (Cont'd)

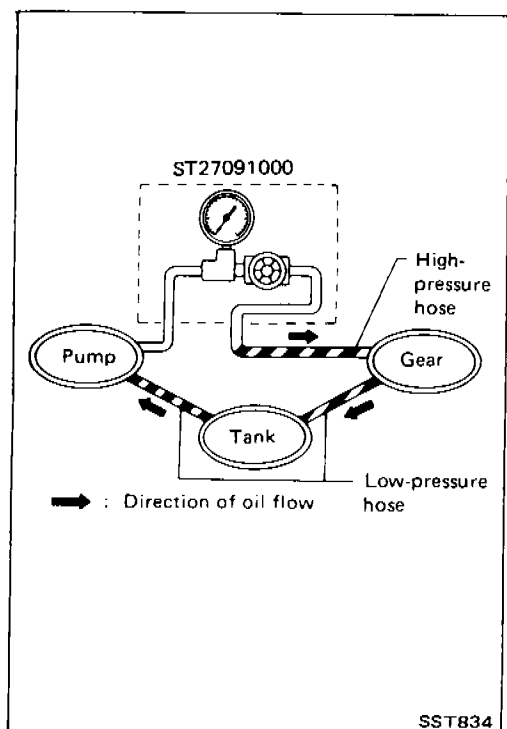

WARNING:

Warm up engine with shut-off valve fully opened. If engine is started with shut-off valve closed, oil pressure in oil pump will increase to relief pressure, resulting in an abnormal rise in oil temperature.

3. Check pressure with steering wheel fully turned to left and right positions with engine idling at 1,000 rpm.

CAUTION:

Do not hold the steering wheel in a locked position for more than 15 seconds.

Oil pump maximum standard pressure:
6,865 kPa (68.6 bar, 70 kg/cm², 995 psi)
at idling

4. If oil pressure is below the standard pressure, slowly close shut-off valve and check pressure.
 - When pressure reaches standard pressure, gear is damaged.
 - When pressure remains below standard pressure, pump is damaged.

CAUTION:

Do not close shut-off valve for more than 15 seconds.

5. If oil pressure is higher than standard pressure, pump is damaged.
6. After checking hydraulic system, remove Tool and add fluid as necessary, then completely bleed air out of system.

STEERING WHEEL AND STEERING COLUMN

L.H.D.

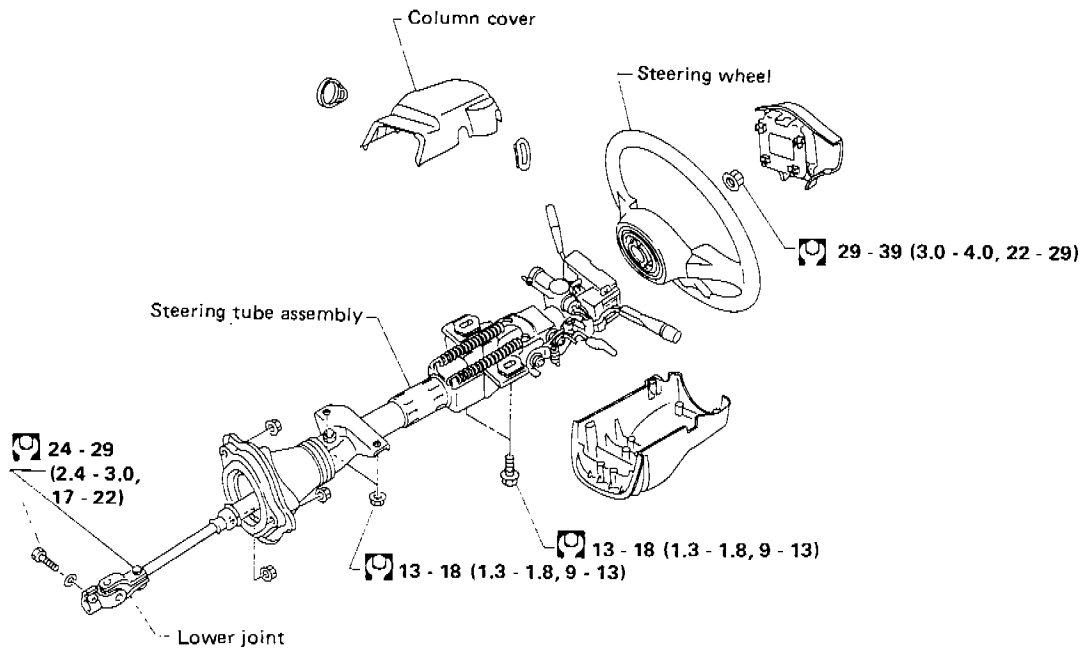

R.H.D.

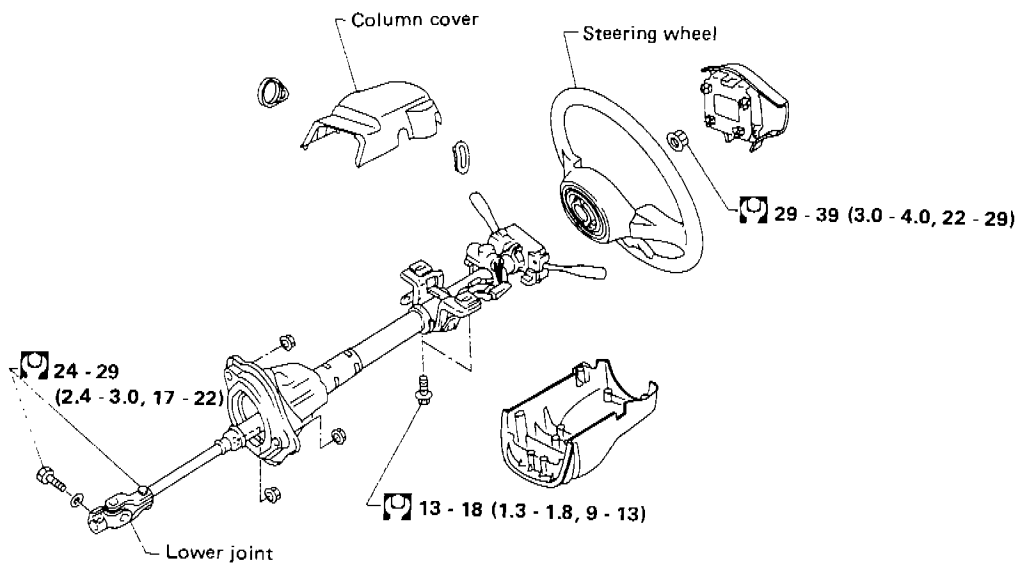

: N·m (kg·m, ft·lb)

SST144B

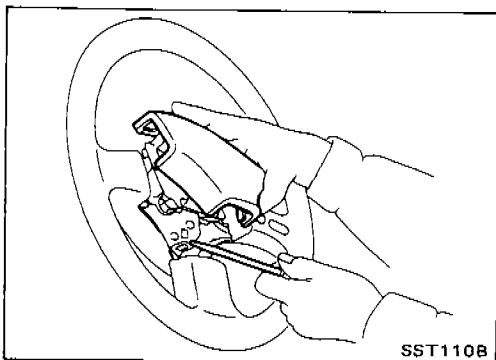

Removal

STEERING WHEEL

- Pull out horn pad.

If it is hard to pull out horn pad, temporarily loosen fixing screw of horn pad retaining spring.

STEERING WHEEL AND STEERING COLUMN

Removal (Cont'd)

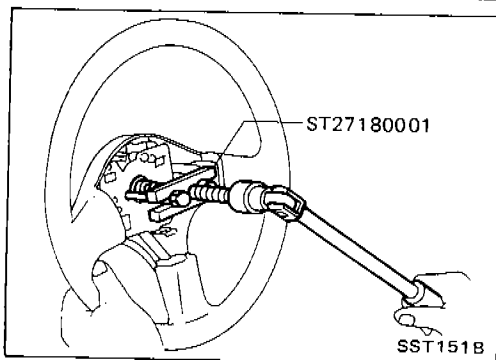
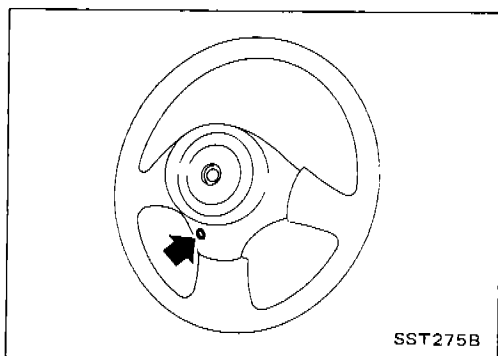

- Remove steering wheel with Tool.

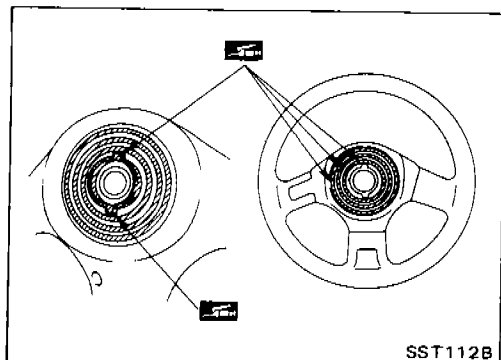

Installation

STEERING WHEEL

- When installing steering wheel, apply multi-purpose grease to entire surface of turn signal cancel pin (both portions) and also to horn contact slip ring.

STEERING COLUMN

- When installing steering column, fingertighten all lower bracket and clamp retaining bolts; then tighten them securely. Do not apply undue stress to steering column.

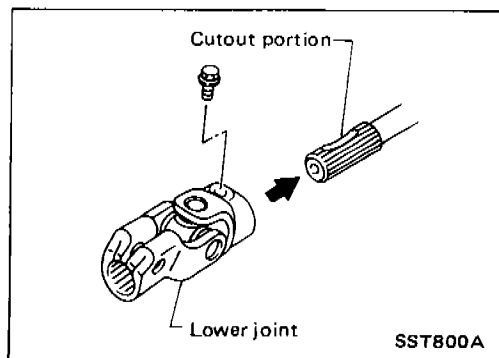

- When attaching coupling joint, be sure tightening bolt faces cutout portion.

CAUTION:

After installing steering column, turn steering wheel to make sure it moves smoothly and that the number of turns from the straight forward position to left and right locks are equal. Be sure that the steering wheel is in a neutral position when driving straight ahead.

STEERING WHEEL AND STEERING COLUMN

Disassembly and Assembly

R.H.D.

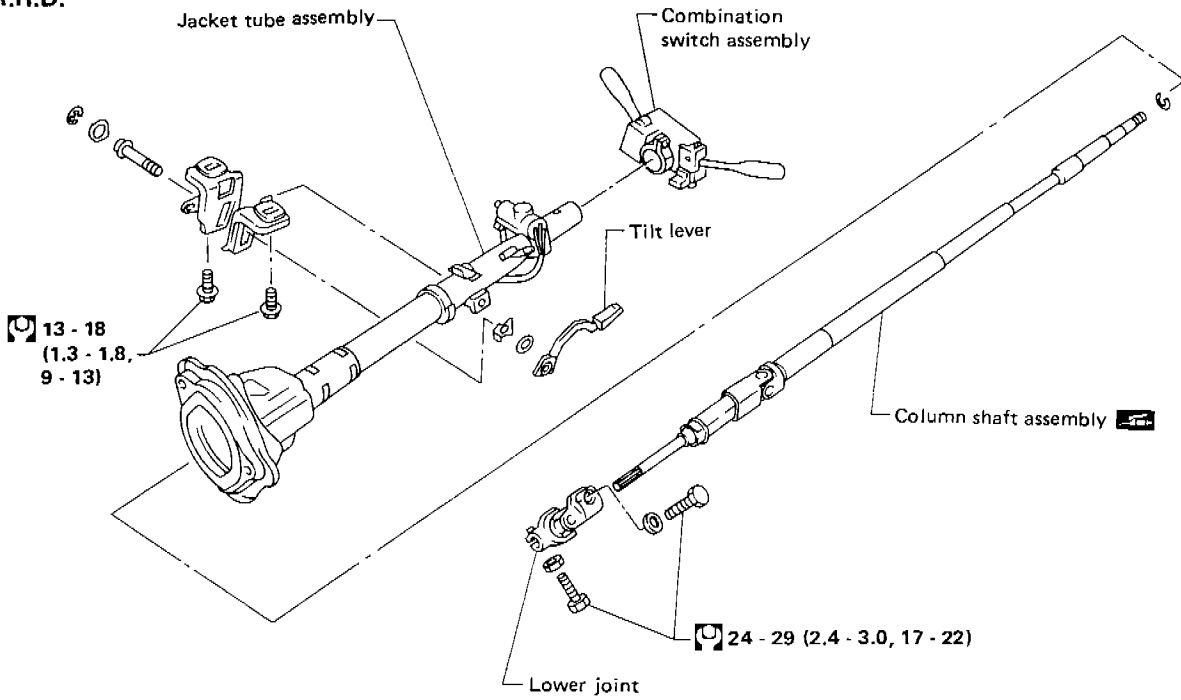

L.H.D.

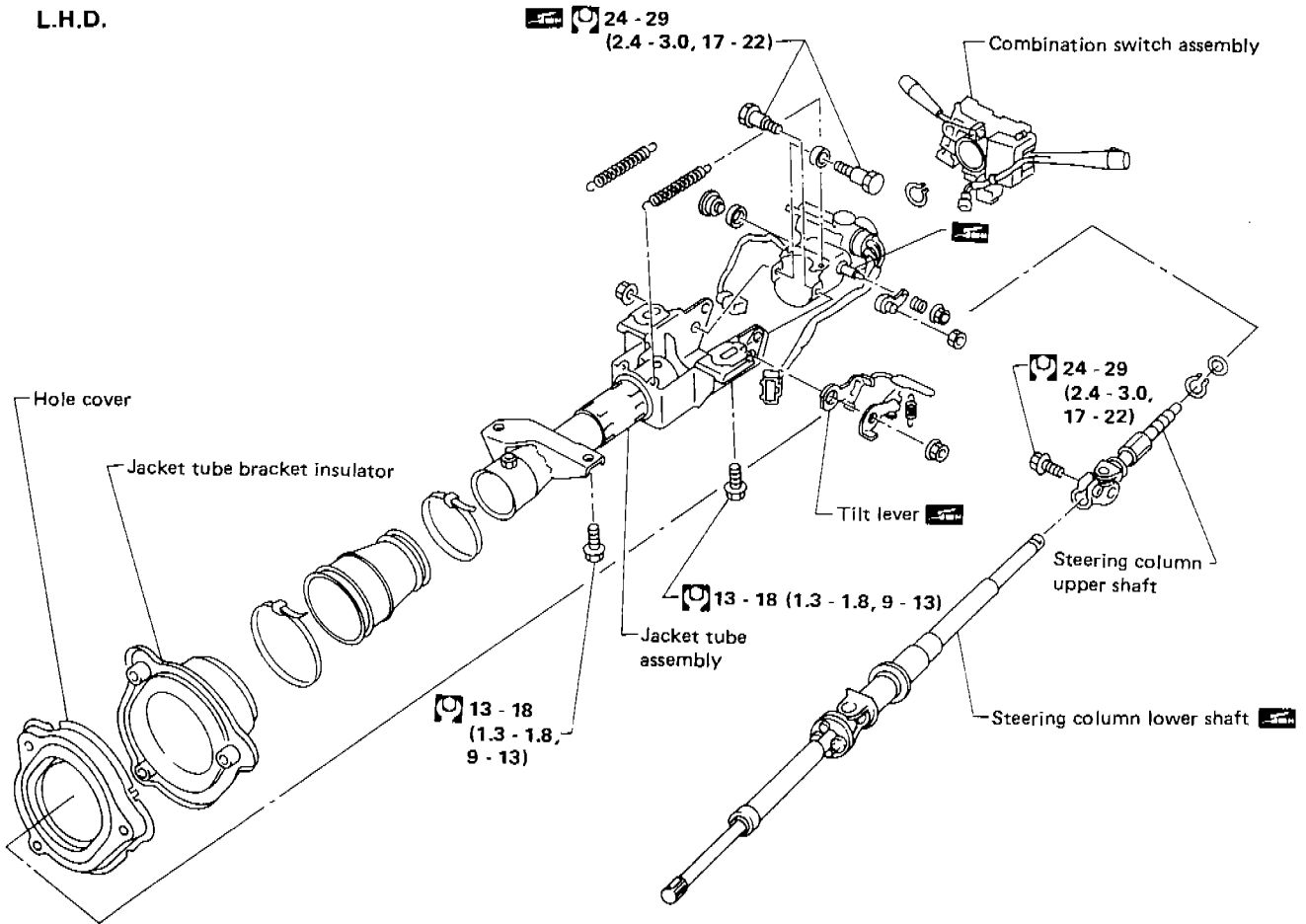

: N·m (kg·m, ft·lb)

SST145B

STEERING WHEEL AND STEERING COLUMN

Disassembly and Assembly (Cont'd)

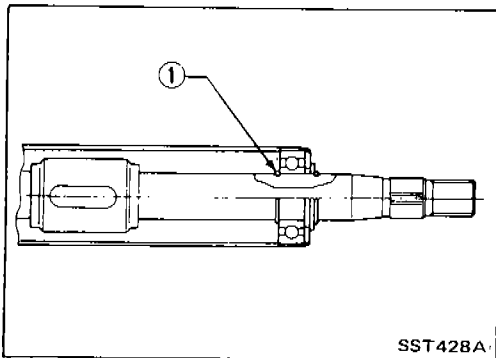

- When disassembling and assembling, unlock steering lock with key.
- Ensure that rounded surface of snap ring faces toward bearing when snap ring is installed.
- Install snap ring ① before inserting shaft into jacket tube.

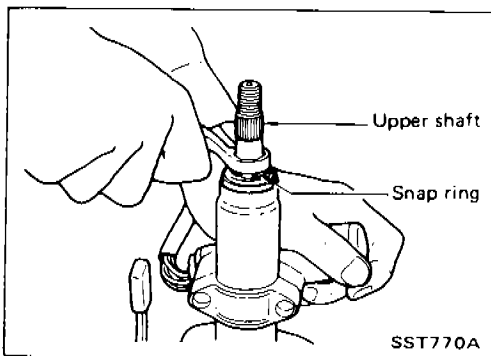

- Install snap ring on upper shaft with box wrench.

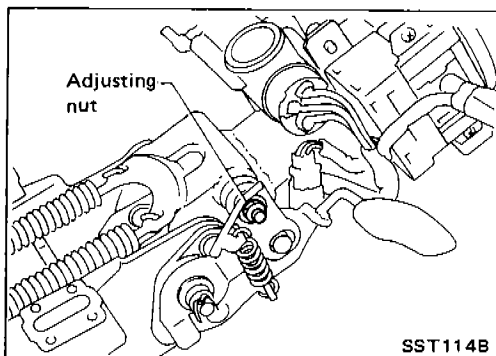

- Tilt mechanism (Jumping tilt only)
 - Tighten adjusting nut to specification.
 - : 4 - 5 N·m (0.4 - 0.5 kg-m, 2.9 - 3.6 ft-lb)

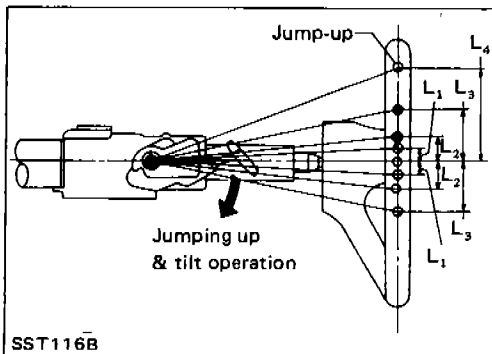

- After installing steering column, check tilt mechanism operation.

- L₁: 9.8 mm (0.386 in)
- L₂: 19.5 mm (0.768 in)
- L₃: 29.3 mm (1.154 in)
- L₄: 58.2 mm (2.291 in)

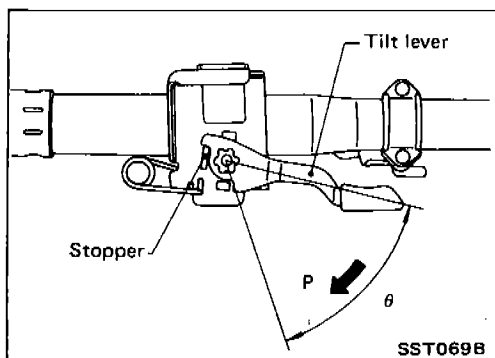

- Adjust tilt lever as follows: (R.H.D. tilt only)
 - When tilt lever contacts stopper, tighten adjusting bolt securely.
 - Turn tilt lever by 90° (θ) in direction "P" to check that steering column moves smoothly without binding.
 - Return tilt lever to position θ . Make sure there is no free play (=0) of steering column when steering wheel is pushed down by force.
 - Install lock washer and E-ring.

STEERING WHEEL AND STEERING COLUMN

Disassembly and Assembly (Cont'd)

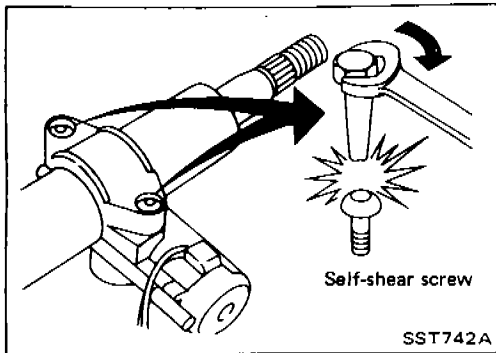

- Steering lock
- a) Break self-shear type screws with a drill or other appropriate tool.
- b) Install self-shear type screws and then cut off self-shear type screw heads.

Inspection

- When steering wheel can not be rotated smoothly, check the steering column for the following matters and replace damaged parts.
 - a. Check column bearings for damage or unevenness. Lubricate with recommended multi-purpose grease or replace steering column as an assembly, if necessary.
 - b. Check steering column lower shaft for deformation or breakage. Replace if necessary.
- When the vehicle is involved in a light collision, check steering column length " L_1 " and steering column lower shaft length " L_2 ". If it is not within specifications, replace steering column as an assembly.

R.H.D.:

Steering column length " L_1 "

715.2 - 716.8 mm (28.16 - 28.22 in)

Steering column lower shaft length " L_2 "

273.7 mm (10.78 in)

L.H.D.:

Steering column length " L_1 "

652.9 - 654.5 mm (25.70 - 25.77 in)

Steering column lower shaft length " L_2 "

324.7 mm (12.78 in)

L.H.D. and R.H.D.

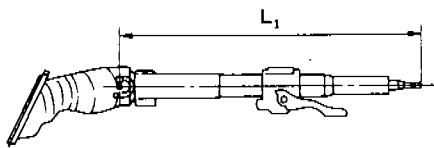

R.H.D.

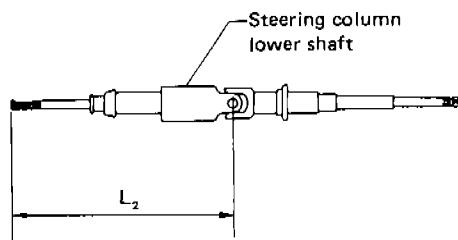

L.H.D.

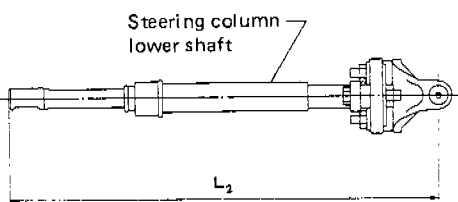

POWER STEERING GEAR AND LINKAGE (Model PR24SC and PR26SC)

Removal and Installation

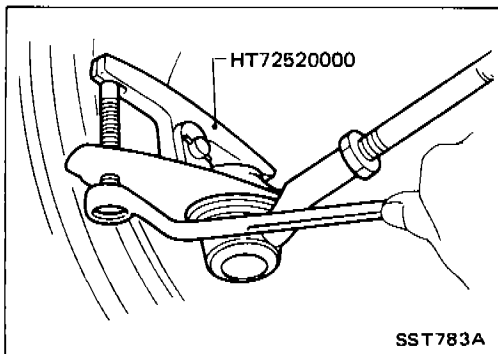
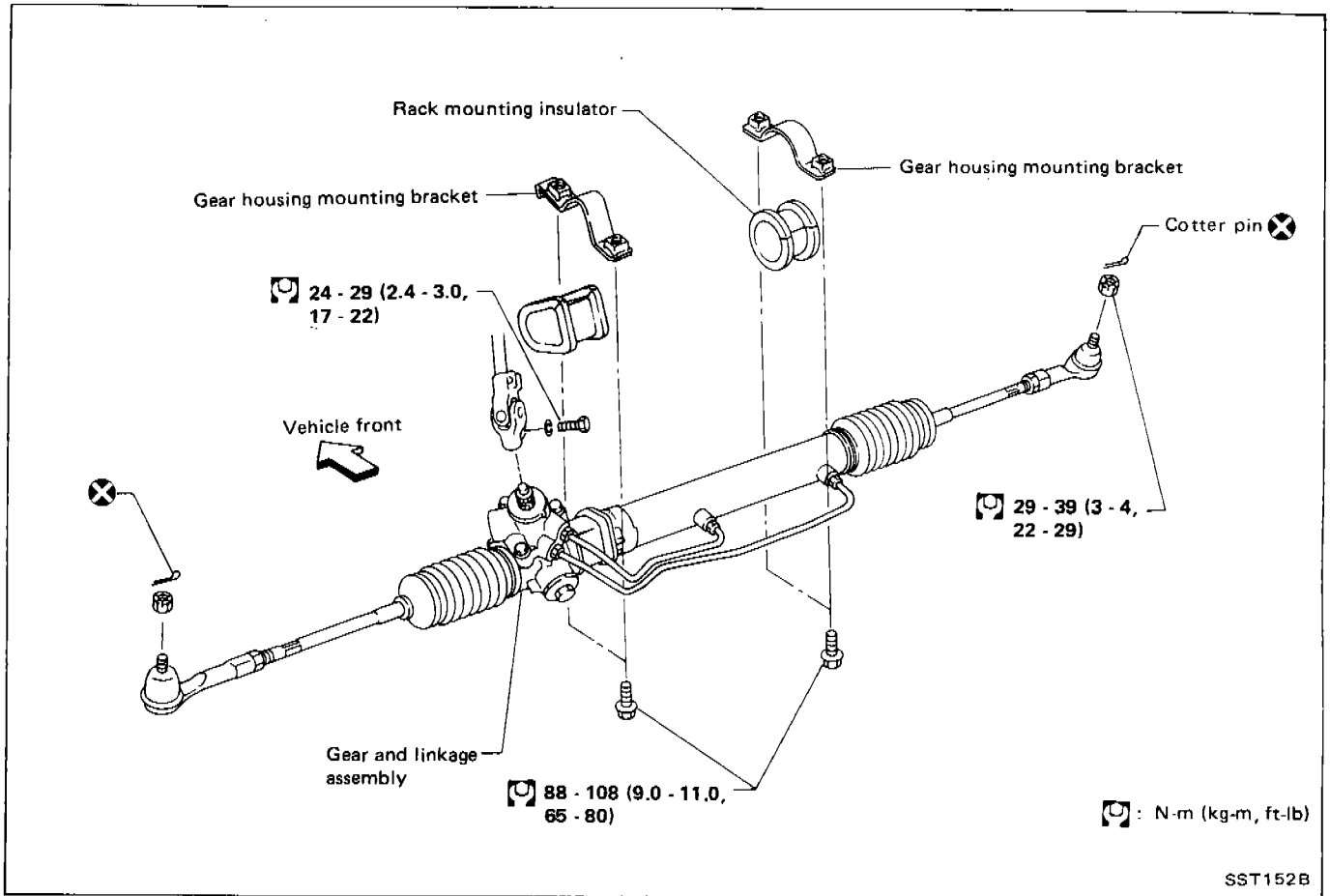

- Detach tie-rod outer sockets from knuckle arms with Tool.

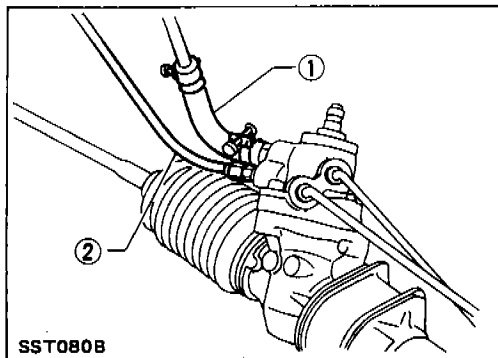

- Install pipe connector.

① Low-pressure side

☞: 27 - 39 N·m (2.8 - 4.0 kg·m, 20 - 29 ft·lb)

② High-pressure side

☞: 15 - 25 N·m (1.5 - 2.5 kg·m, 11 - 18 ft·lb)

POWER STEERING GEAR AND LINKAGE (Model PR24SC and PR26SC)

Removal and Installation (Cont'd)

- Observe specified tightening torque when tightening high-pressure and low-pressure pipe connectors. Excessive tightening can damage threads or damaged connector O-ring.
- The O-ring in low-pressure pipe connector is larger than that in high-pressure connector. Take care to install the proper O-ring.

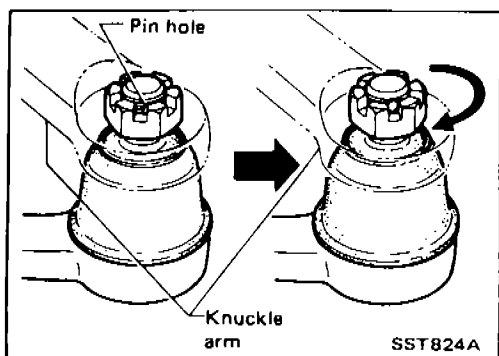

- Initially, tighten nut on tie-rod outer socket and knuckle arm to 29 to 39 N·m (3 to 4 kg-m, 22 to 29 ft-lb). Then tighten further to align nut groove with first pin hole so that cotter pin can be installed.

CAUTION:
Tightening torque must not exceed 49 N·m (5 kg-m, 36 ft-lb).

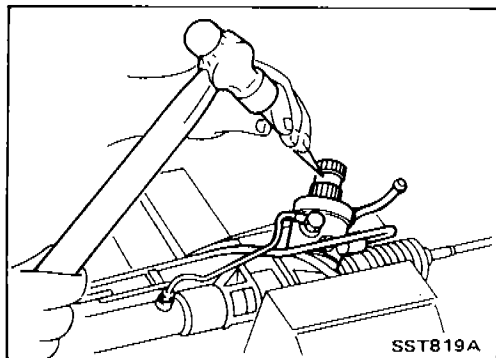

- Before removing lower joint from gear, set gear in neutral (wheels in straight-ahead position). After removing lower joint, put matching mark on pinion shaft and pinion housing to record neutral position of gear.
- To install, set left and right dust boots to equal deflection, and attach lower joint by aligning matching marks of pinion shaft and pinion housing.

POWER STEERING GEAR AND LINKAGE (Model PR24SC and PR26SC)

Disassembly and Assembly

The table below lists four ways to repair oil leaks in the steering gear, depending on the location of the leak. See the following figure for oil leak locations.

| Position of oil leak Item | ① Rear housing cover and rear housing | ② Boot | ③ Boot | ④ Gear housing tube |
|------------------------------|--------------------------------------------------------------------------------------------------------------------------------------------------------------------------------------------------------------------------------------------------------------------------------------------------------------------------------------------------------------------------------------------------------------------------------------------------------------------------------------------------------------------------------------------------------------------------------------------------------------------------------------------------------------------------------------------------------------------------------------|----------------------------------------------------------------------------------------------------------------|--------------------------------------------------------------------------------------------------------------------------------------------------------------------------------------|-----------------------------------------------------------------------------------------------------------------------|
| Operation | <ul style="list-style-type: none"> ■ Replacement • Rear oil seal • Pinion oil seal • O-ring • Snap ring | <ul style="list-style-type: none"> ■ Replacement • Rack oil seal • Boot clamp | <ul style="list-style-type: none"> ■ Replacement • Rack oil seals • Rack oil seal • O-ring • Back-up collar • Boot clamp | <ul style="list-style-type: none"> ■ Replacement • Gear housing tube • Copper washer |
| Procedure | <p>Remove gear from vehicle.</p> <p>Measure rack starting force and pinion rotating torque.</p> <div style="display: flex; justify-content: space-around; align-items: center;"> <div style="border: 1px solid black; padding: 5px; width: 15%;">Replace parts described above.</div> <div style="border: 1px solid black; padding: 5px; width: 15%;">Replace rack oil seal.</div> <div style="border: 1px solid black; padding: 5px; width: 15%;">Replace parts described above.</div> <div style="border: 1px solid black; padding: 5px; width: 15%;">Replace gear housing tube.</div> </div> <p>Measure pinion rotating torque.</p> <p>Adjust adjusting screw.</p> <p>Measure rack starting force and pinion rotating torque.</p> | | | |
| Service parts to be prepared | <ul style="list-style-type: none"> • Pinion seal kit | <ul style="list-style-type: none"> • Gear housing seal kit | <ul style="list-style-type: none"> • Rack oil seal • Pinion seal kit | <ul style="list-style-type: none"> • Gear housing seal kit |

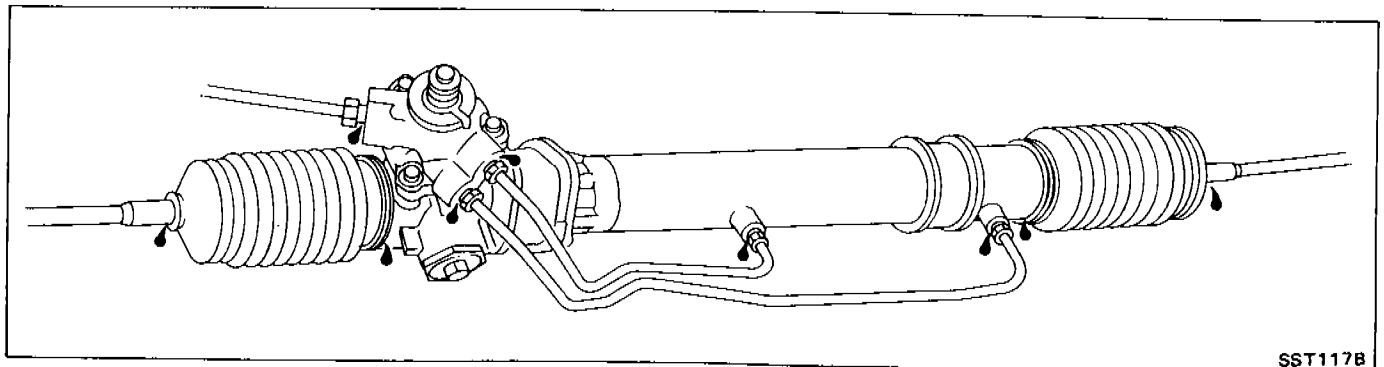

POWER STEERING GEAR AND LINKAGE (Model PR24SC and PR26SC)

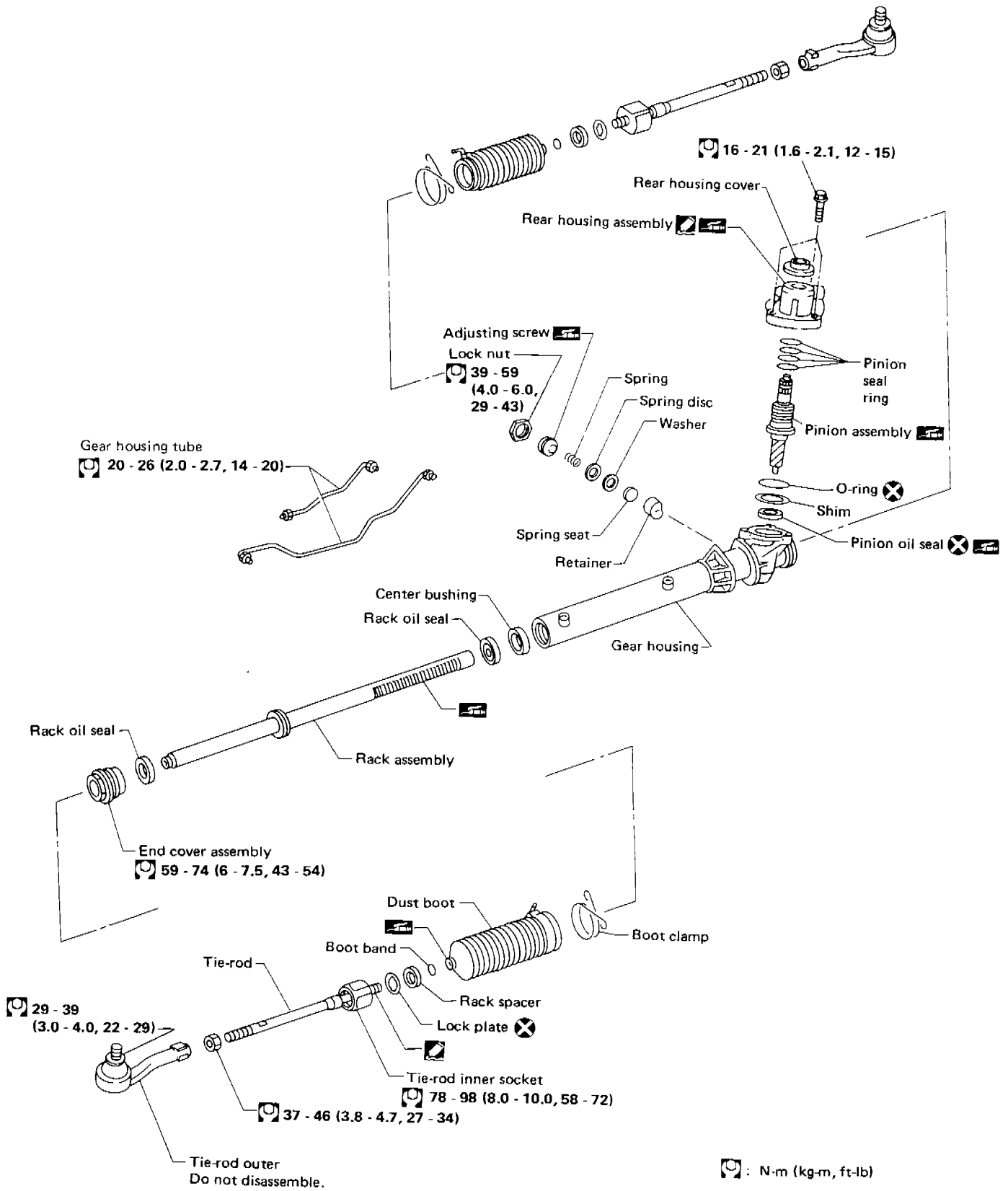

SST118B

POWER STEERING GEAR AND LINKAGE (Model PR24SC and PR26SC)

Disassembly

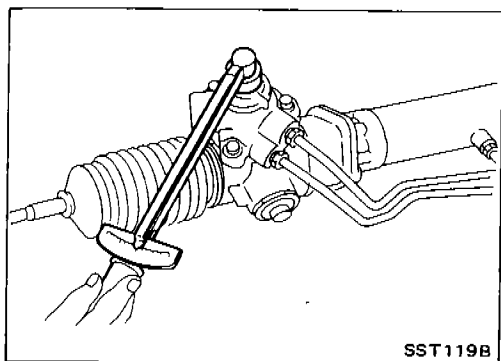

1. Prior to disassembling, measure pinion rotating torque. Record the pinion rotating torque as a reference.
 - Before measuring, disconnect gear housing tube and drain fluid.
 - Use soft jaws when holding steering gear housing. Handle gear housing carefully, as it is made of aluminum. Do not grip cylinder in a vise.
2. Remove pinion gear.
 - Be careful not to damage pinion gear when removing pinion seal ring.

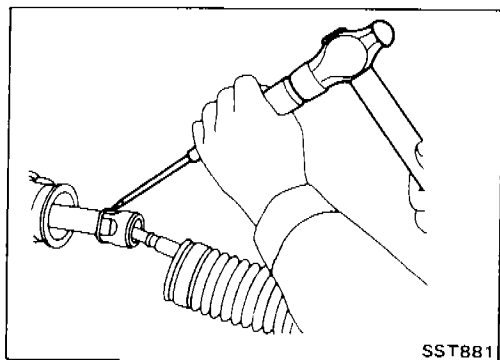

3. Remove tie-rod outer sockets and boots.
4. Loosen tie-rod inner socket by prying up staked portion, and remove socket.
5. Remove retainer.
6. Remove pinion assembly.

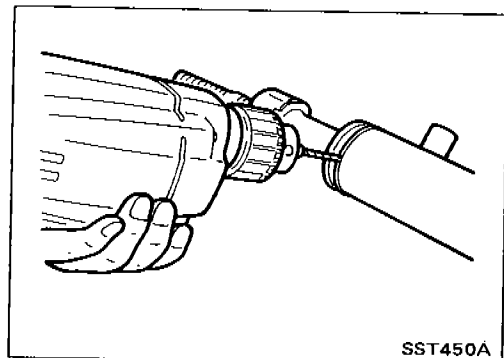

7. Drill staked portion of gear housing end with drill of 2 to 2.5 mm (0.079 to 0.098 in) diameter, until the staking is eliminated.

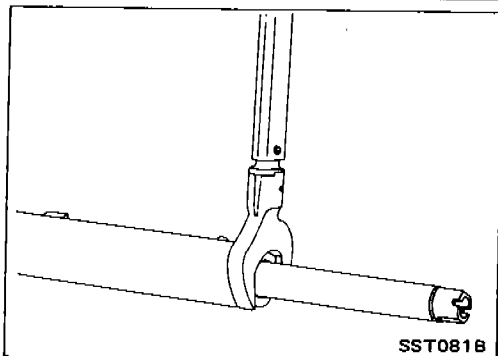

8. Remove end cover assembly with suitable tool.
9. Draw out rack assembly.

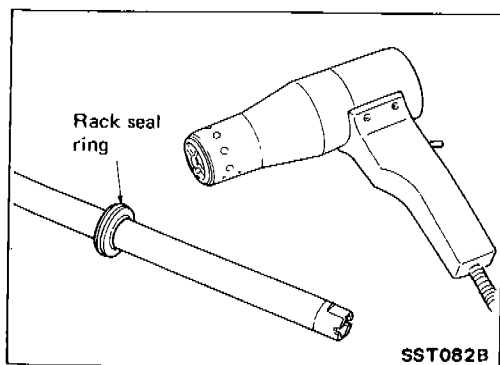

10. Remove rack seal ring.
 - Using a heat gun, heat rack seal to approximately 40°C (104°F).
 - Remove rack seal ring. Be careful not to damage rack.
 - Replace rack seal ring and O-ring with new ones.

POWER STEERING GEAR AND LINKAGE (Model PR24SC and PR26SC)

Disassembly (Cont'd)

11. Remove center bushing and rack oil seal using tape wrapped socket and extension bar.

Do not scratch inner surfaces of pinion housing.

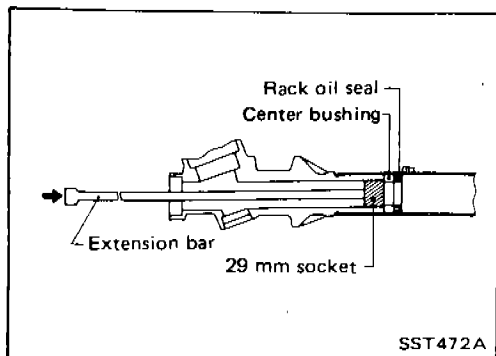

Assembly

1. Using a heat gun, heat rack seal ring (made of Teflon) to approximately 40°C (104°F) and install it onto rack with your hand.

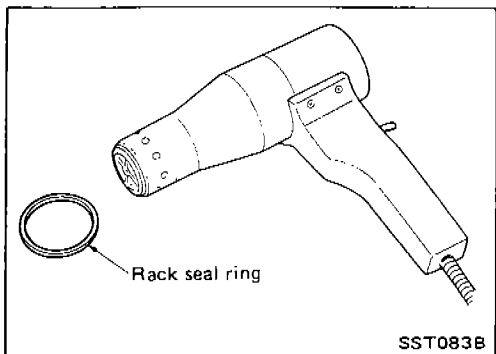

● Using Tool, compress periphery of rack seal ring (made of Teflon) to position and secure it on rack.

Always insert the tool from the rack gear side.

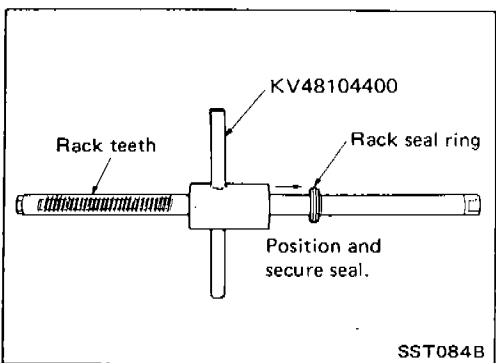

2. Insert rack oil seal.

● Place plastic film into rack oil seal to prevent damage by rack teeth.

● Always remove plastic film after rack oil seal is positioned properly.

● Make sure lips of rack oil seal face each other.

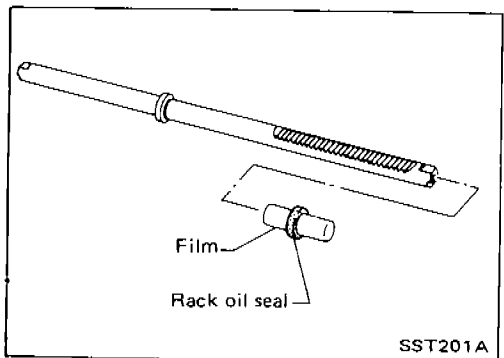

3. Install center bushing and rack oil seal with rack assembly.

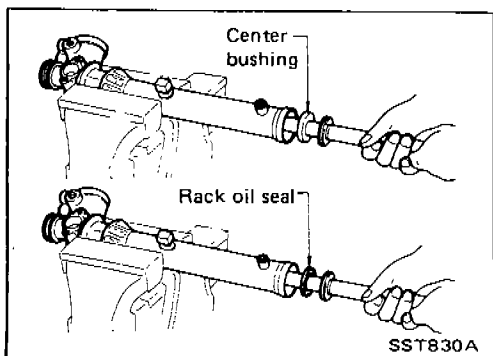

POWER STEERING GEAR AND LINKAGE (Model PR24SC and PR26SC)

Assembly (Cont'd)

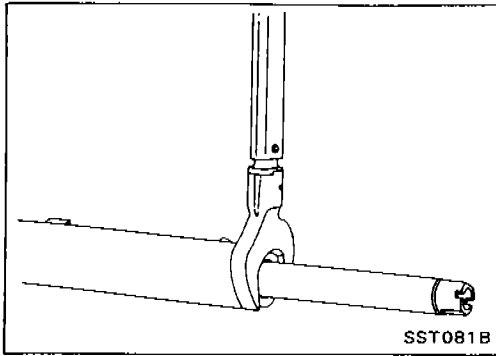

4. Tighten end cover assembly with suitable tool.

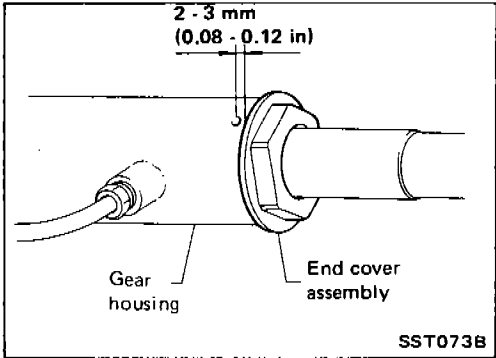

5. Fasten end cover assembly to gear housing by staking.

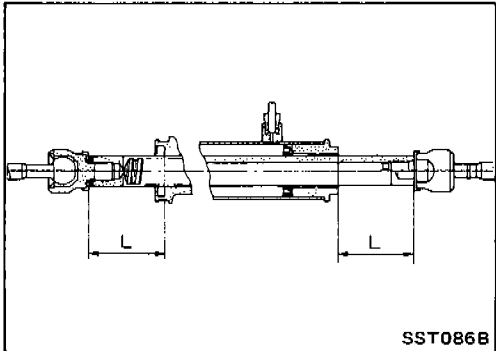

6. Set rack gear in neutral position.
Measured length "L":
Refer to S.D.S.

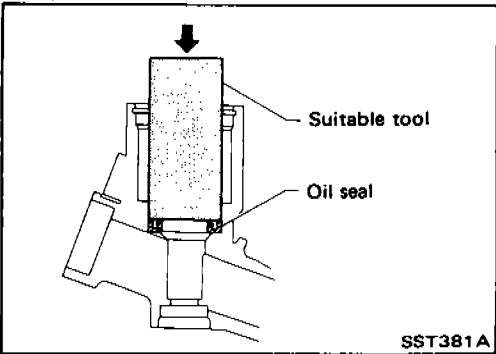

7. Coat seal lip of oil seal with multi-purpose grease and install new pinion oil seal to pinion housing of gear housing with suitable tool.
 - Make sure lip of oil seal faces up when installed.

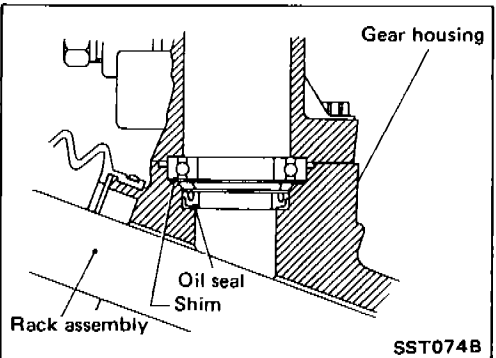

8. Install pinion bearing adjusting shim(s).
 - Whenever pinion assembly, gear housing and rear housing are disassembled, replace shim(s) with new ones. Always use the same number of shim(s) when replacing.

POWER STEERING GEAR AND LINKAGE (Model PR24SC and PR26SC)

Assembly (Cont'd)

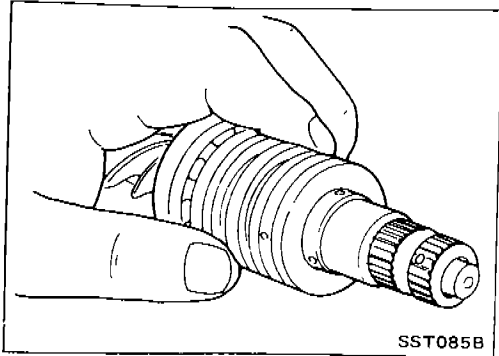

9. Install pinion seal ring on pinion gear assembly.
 - Using a heat gun, heat pinion seal ring to approximately 40°C (104°F) before installing it onto pinion gear assembly.
 - Make sure pinion seal ring is properly settled in valve groove.

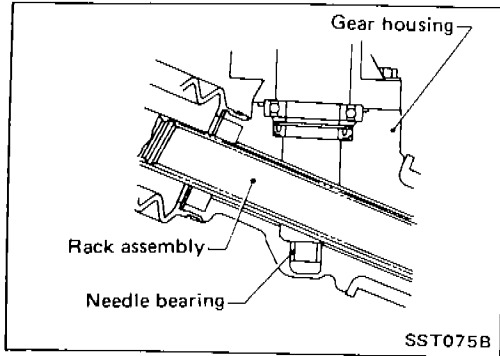

10. Apply a coat of multi-purpose grease to needle bearing roller and oil seal lip before installing pinion assembly in gear housing.

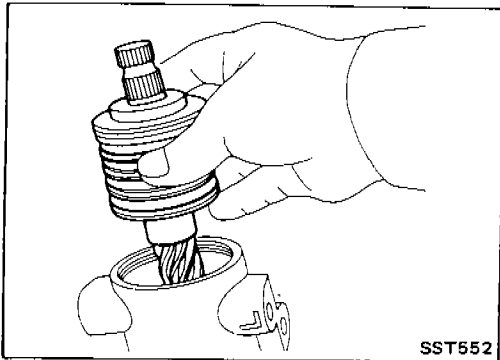

11. Install pinion assembly to pinion housing of gear housing. **Be careful not to damage pinion oil seal.**

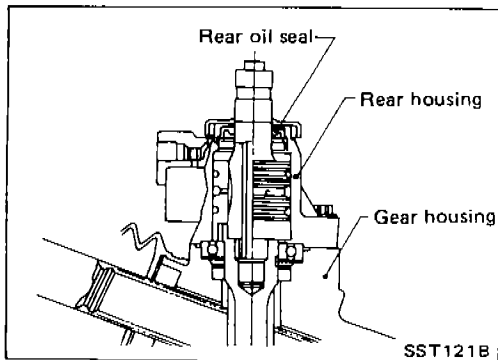

12. Apply a coat of multi-purpose grease to rear oil seal lip before installing rear housing.

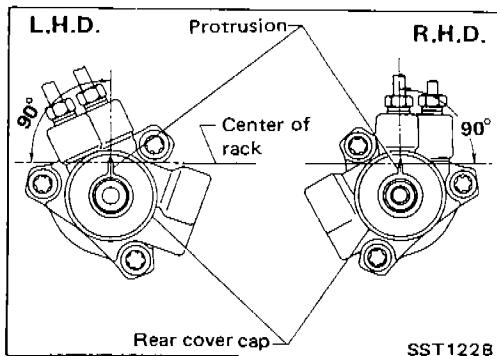

13. Install rear cover cap so that protrusion of rear housing cover is positioned as shown in figure at left. **Be careful not to damage worm ring and oil seal.**

POWER STEERING GEAR AND LINKAGE (Model PR24SC and PR26SC)

Assembly (Cont'd)

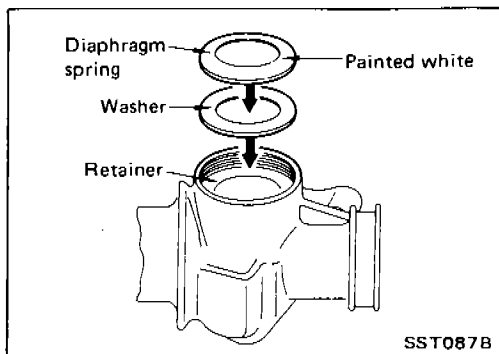

14. Install diaphragm spring at retainer.

- Always install retainer, spring washer and diaphragm spring in that order.
- Make sure convex end (painted white) of diaphragm spring faces outward when installing.

15. Install retainer spring and adjusting screw temporarily.

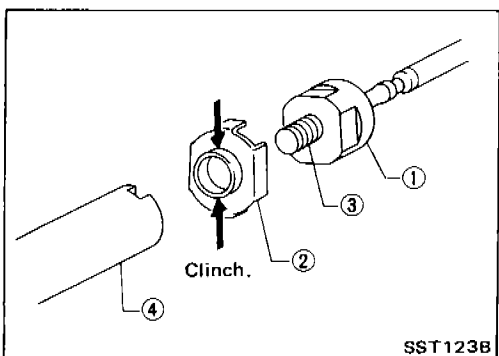

16. Install new lock plate.

- Attach lock plate ② to side rod inner socket ①.
- Apply locking sealant to inner socket threads ③. Screw inner socket into rack ④ and tighten to specified torque.
- Clinch two places of lock plate at rack's groove.

CAUTION:

To prevent scratching the boot, remove burrs from lock plate.

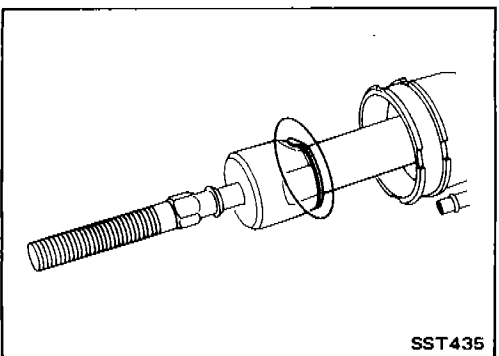

17. Tighten inner socket and securely bend lock plate at 2 cutout portions of inner socket.

To prevent damage to boot, remove burrs after bending lock plate.

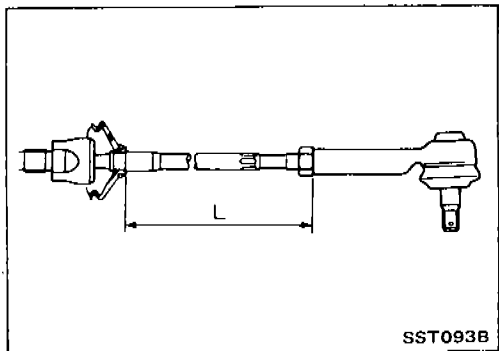

18. Tighten outer socket lock nut.

Tie-rod length "L":

Refer to S.D.S.

Screwed length "Q":

32.2 mm (1.268 in) or more

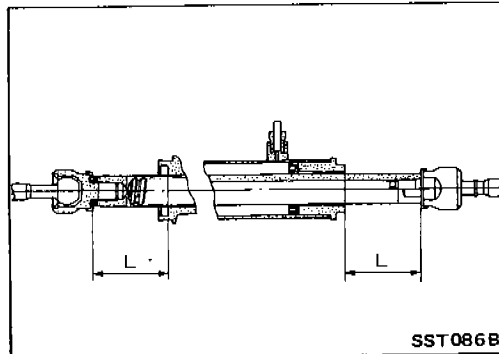

19. Measure rack stroke.

Measured length "L":

Refer to S.D.S.

POWER STEERING GEAR AND LINKAGE (Model PR24SC and PR26SC)

Assembly (Cont'd)

20. Before installing boot, coat the contact surfaces between boot and tie-rod with grease.

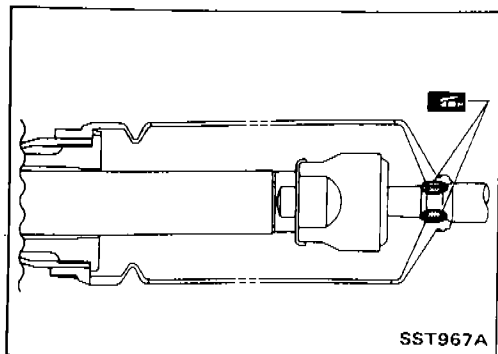

21. Install boot clamps.

- To install, wrap boot clamp around boot groove twice. Tighten clamp by twisting rings at both ends 4 to 4-1/2 turns with screwdriver while pulling with a force of approx. 98 N (10 kg, 22 lb).

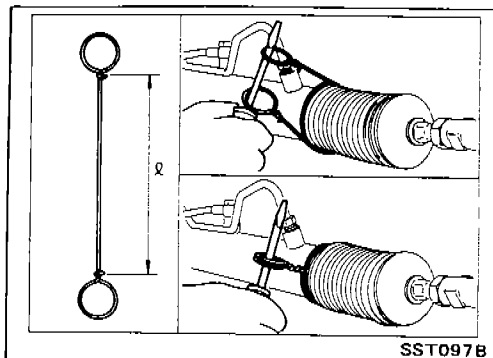

- Install boot clamp so that it is to the rear of the vehicle when gear housing is attached to the body. (This will prevent interference with other parts.)

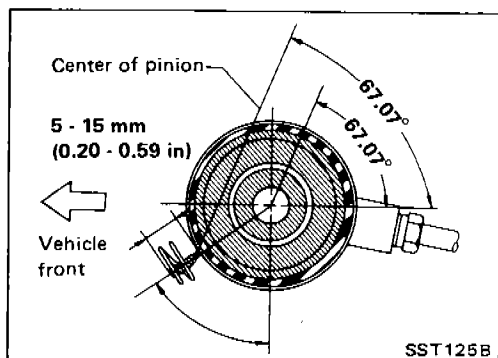

- Twist boot clamp in the direction shown in figure at left.

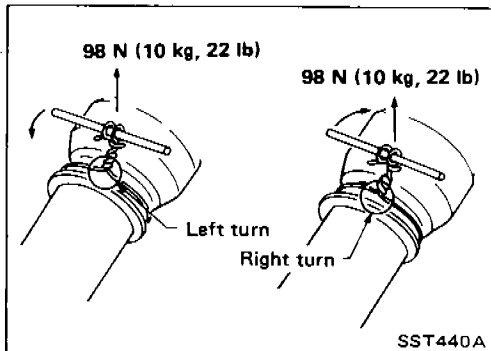

- After twisting boot clamp, bend twisted and diagonally so it does not contact boot.

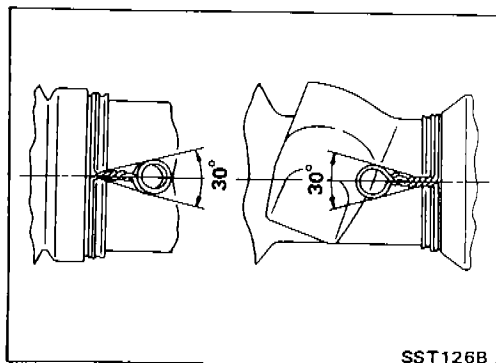

POWER STEERING GEAR AND LINKAGE (Model PR24SC and PR26SC)

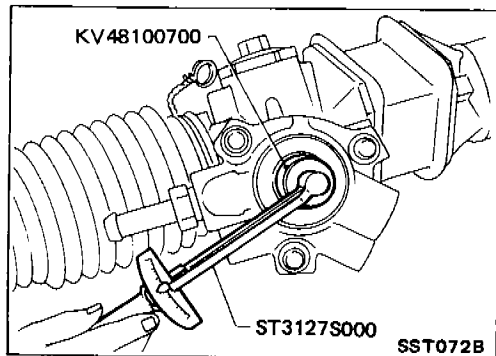
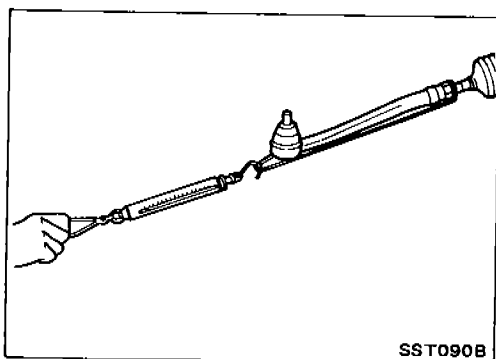
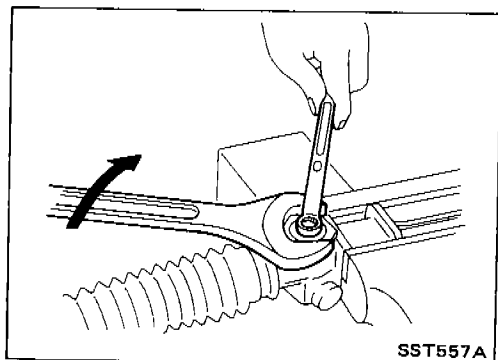
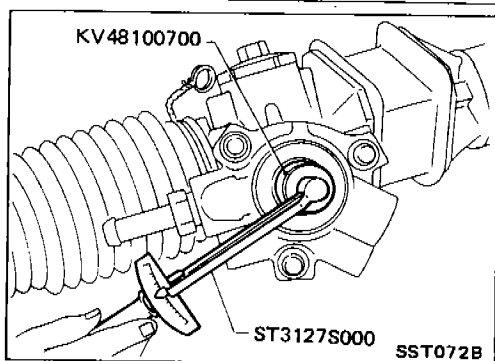
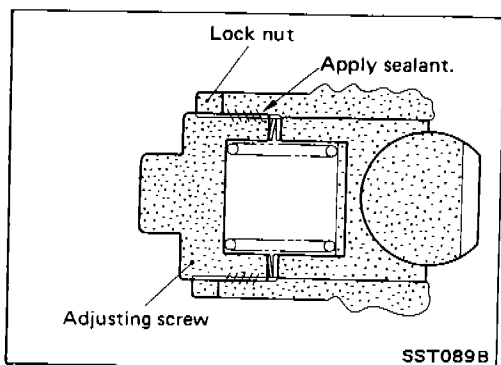

Adjustment

Adjust pinion rotating torque as follows:

1. Set gears to Neutral without fluid in the gear.
2. Coat the adjusting screw with locking sealant and screw it in.
3. Lightly tighten lock nut.
4. Tighten adjusting screw to a torque of 4.9 to 5.9 N·m (50 to 60 kg-cm, 43 to 52 in-lb).
5. Loosen adjusting screw, then retighten it to 0.05 to 0.20 N·m (0.5 to 2 kg-cm, 0.43 to 1.74 in-lb).
6. Move rack over its entire stroke several times.
7. Measure pinion rotating torque within the range of 180° from neutral position.
Stop the gear at the point of maximum torque.
8. Loosen adjusting screw, then retighten it to 4.9 to 5.9 N·m (50 to 60 kg-cm, 43 to 52 in-lb).
9. Loosen adjusting screw by 40° to 60°.
10. Prevent adjusting screw from turning, and tighten lock nut to specified torque.
11. Check steering gear for rack sliding frictional force.
Around neutral point of rack stroke
 $\pm 5.5 \text{ mm } (\pm 0.217 \text{ in})$
122.6 - 166.7 N (12.5 - 17 kg, 27.6 - 37.5 lb)
Except for neutral point:
122.6 - 186.3 N (12.5 - 19 kg, 27.6 - 41.9 lb)
If sliding frictional force is out of specification, repeat the adjustment procedure, starting from No. 4.
After the readjustment, if sliding force is still out of specification, steering gear is damaged.
12. Measure pinion rotating torque within the range of $\pm 100^\circ$ from the neutral point.
Average rotating torque
[(Max. measured value + Min. measured value) x 0.5]:
0.8 - 1.3 N·m (8 - 13 kg-cm, 6.9 - 11.3 in-lb)
Maximum torque increment:
Less than 0.4 N·m (4 kg-cm, 3.5 in-lb)
Except for above mentioned measuring range:
Maximum rotating torque
1.9 N·m (19 kg-cm, 16 in-lb)
Maximum torque increment
Less than 0.6 N·m (6 kg-cm, 5.2 in-lb)

POWER STEERING GEAR AND LINKAGE (Model PR24SC and PR26SC)

Adjustment (Cont'd)

- If pinion rotating torque is not within specification, readjust it.
- After the readjustment, if pinion rotating torque is still out of specification, steering gear is damaged.

Inspection

Thoroughly clean all parts in cleaning solvent or automatic transmission fluid "DEXRON™ Type", and blow dry with compressed air, if available.

BOOT

Check condition of boot. If cracked excessively, replace it.

RACK

Thoroughly examine rack gear. If damaged, cracked or worn, replace it.

PINION ASSEMBLY

- Thoroughly examine pinion gear. If pinion gear is damaged, cracked or worn, replace it.
- Inspect bearings to see that they roll freely and are free from cracked, pitted, or worn balls, rollers and races. Replace if necessary.

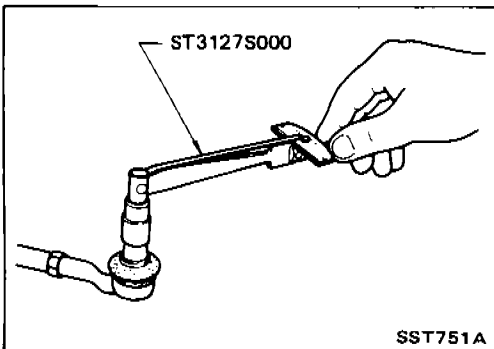
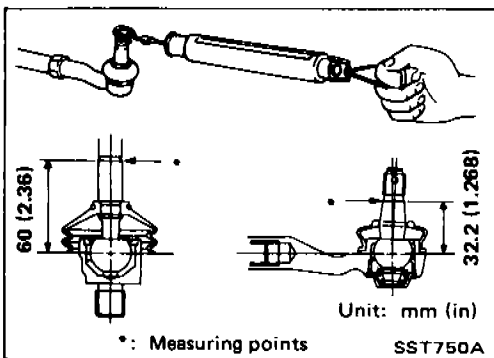

TIE-ROD OUTER AND INNER SOCKET

- Check ball joint for swinging force.

Tie-rod outer ball joint:

9.12 - 91.30 N

(0.93 - 9.31 kg, 2.05 - 20.53 lb)

Tie-rod inner ball joint:

8.14 - 122.6 N

(0.83 - 12.5 kg, 1.83 - 27.6 lb)

- Check ball joint for rotating torque.

Tie-rod outer ball joint:

0.29 - 2.94 N·m

(3.0 - 30.0 kg-cm, 2.6 - 26.0 in-lb)

Tie-rod inner ball joint:

7.4 N·m (75 kg-cm, 65 in-lb) or less

POWER STEERING GEAR AND LINKAGE (Model PR24SC and PR26SC)

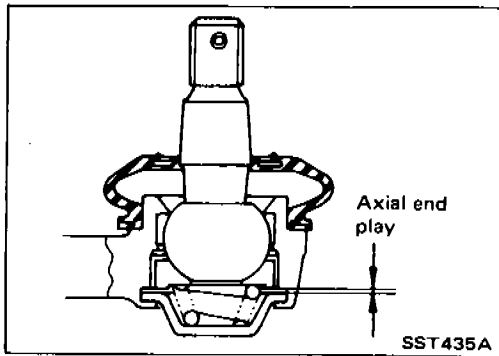

Inspection (Cont'd)

- Check ball joint for axial end play.
 - Tie-rod outer ball joint:**
0.5 mm (0.020 in) or less
 - Tie-rod inner ball joint:**
0 mm (0 in)
- Check condition of dust cover. If cracked excessively, replace it.

GEAR HOUSING CYLINDER

Check gear housing cylinder for scratches or other damage. Replace if necessary.

POWER STEERING OIL PUMP

Disassembly and Assembly

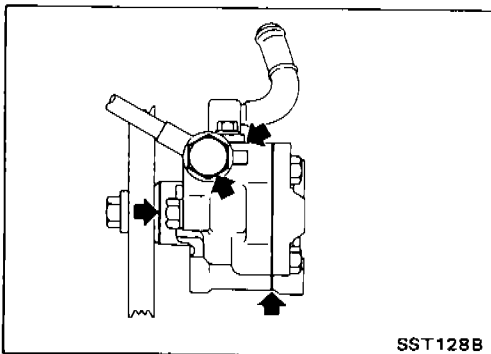
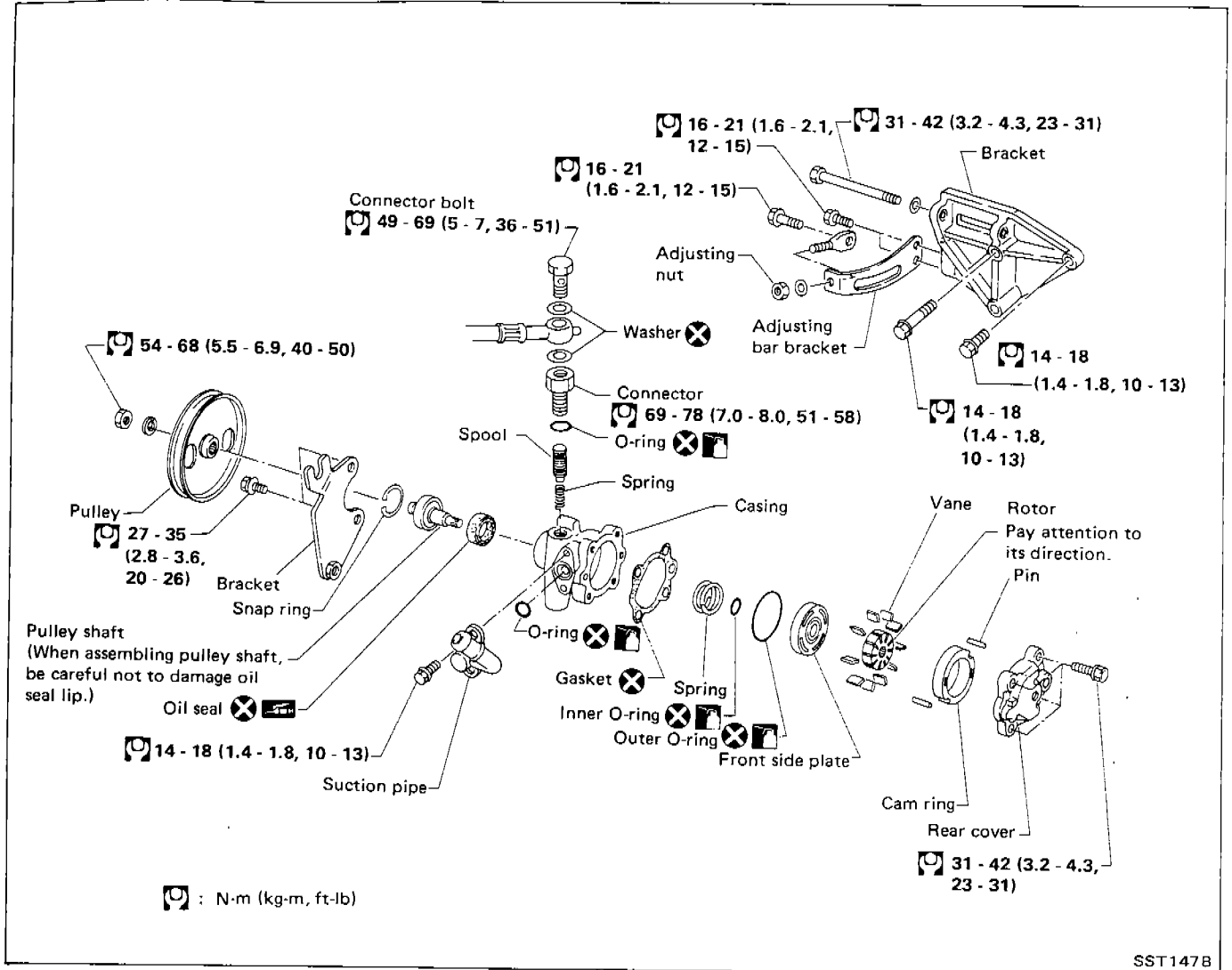

Pre-disassembly Inspection

Disassemble the power steering oil pump only if the following items are found.

- Oil leak from any point shown in the figure
- Deformed or damaged pulley

Disassembly

CAUTION:

- Parts which can be disassembled are strictly limited. Never disassemble parts other than those specified.
- Disassemble in as clean a place as possible.
- Clean your hands before disassembly.
- Do not use rags; use nylon cloths or paper towels.
- Follow the procedures and cautions in the Service Manual.
- When disassembling and reassembling, do not let foreign matter enter or contact the parts.

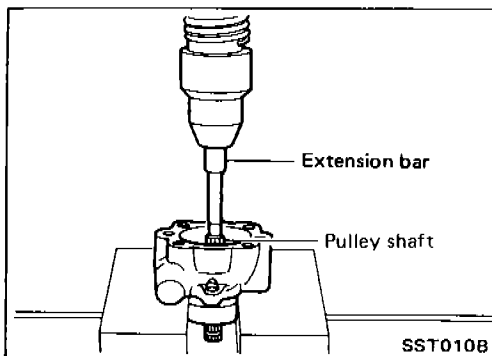

- Remove snap ring, then draw pulley shaft out.
Be careful not to drop pulley shaft.

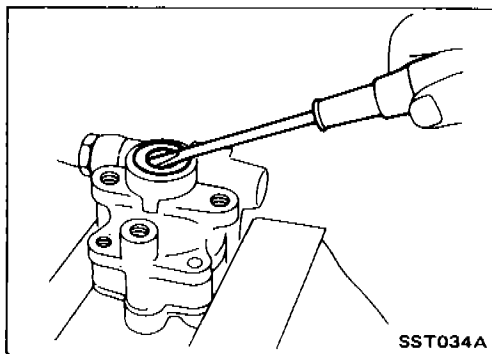

- Remove oil seal.
Be careful not to damage front housing.

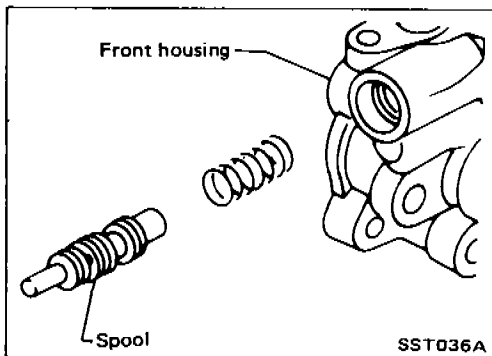

- Remove connector.
Be careful not to drop spool.

Inspection

PULLEY AND PULLEY SHAFT

- If pulley is cracked or deformed, replace it.
- If an oil leak is found around pulley shaft oil seal, replace the seal.
- If serration of pulley or pulley shaft is deformed or worn, replace it.

POWER STEERING OIL PUMP

Assembly

Assemble oil pump in the reverse order of disassembly, noting the following instructions.

- Before installation, coat the O-rings and oil seal with A.T.F.*
 - Make sure O-rings and oil seal are properly installed.
 - When assembling vanes to rotor, rounded surfaces of vanes must face cam case side.
 - Always install new O-rings and oil seal.
 - Be careful of oil seal direction.
- *: Automatic Transmission Fluid

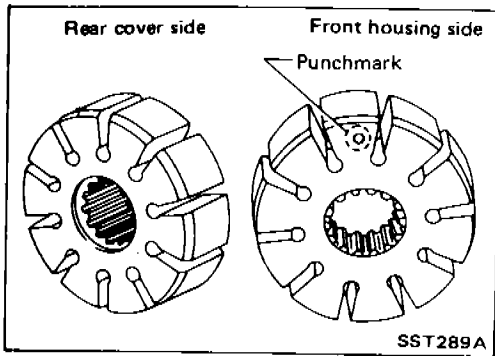

- Pay attention to the direction of rotor.

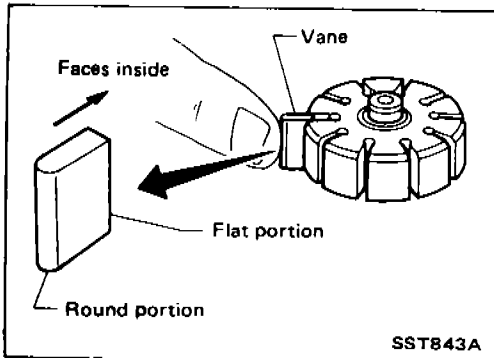

- Install vanes properly.

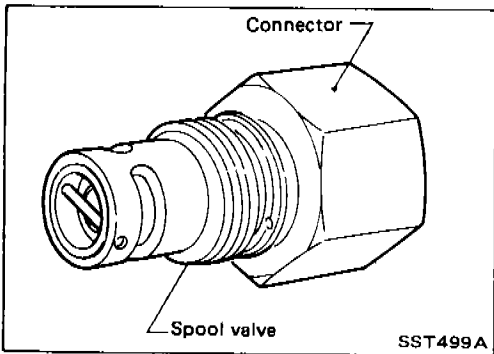

CAUTION:
Do not remove spool valve from connector.

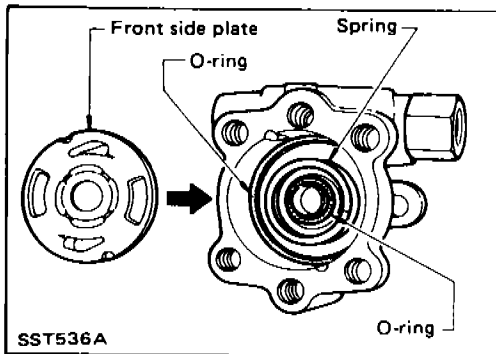

- Apply A.T.F.* to O-ring.
- *: Automatic Transmission Fluid

POWER STEERING OIL PUMP

Assembly (Cont'd)

- Insert pin ② into pin groove ① of front housing and rotor. Then install cam ring ③ as shown at left.

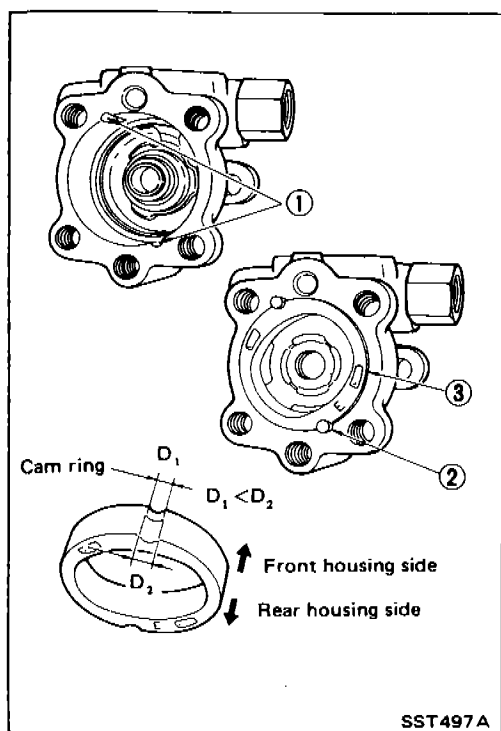

SERVICE DATA AND SPECIFICATIONS (S.D.S.)

General Specifications

| Model | R.H.D. | L.H.D. | |
|---------------------------------------|-------------------|---------------------------|--------|
| | | Except Europe | Europe |
| Steering model | Power steering | | |
| Steering gear type | PR24SC | | PR26SC |
| Turn of steering wheel (Lock to lock) | 3.1 | | 3.2 |
| Steering column type | Collapsible, tilt | Collapsible, jumping tilt | |

Inspection and Adjustment

GENERAL

| | | |
|---------------------------|---------|-------------------|
| Steering wheel axial play | mm (in) | 0 (0) |
| Steering wheel play | mm (in) | 0 - 35 (0 - 1.38) |

STEERING COLUMN

| Model | R.H.D. | L.H.D. |
|------------------------------------------------------|---------------------------------------------|----------------------------------|
| Steering column length "L ₁ " | 715.2 - 716.8 mm (in) (28.16 - 28.22) | 652.9 - 654.5 (25.70 - 25.77) |
| Steering column lower shaft length "L ₂ " | 273.7 (10.78) | 324.7 (12.78) |

R.H.D. and L.H.D.

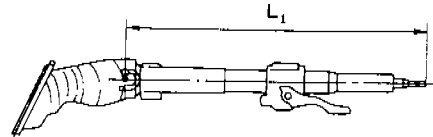

SST098B

R.H.D.

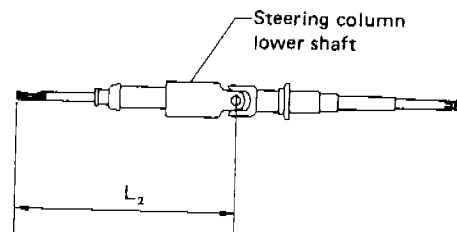

SST115B

L.H.D.

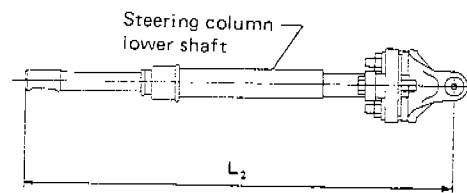

SST146B

SERVICE DATA AND SPECIFICATIONS (S.D.S.)

Inspection and Adjustment (Cont'd)

STEERING GEAR AND LINKAGE

| Steering gear type | PR24SC | PR26SC |
|----------------------------------------|---------------------------------------------|--------|
| Tie-rod outer ball joint | | |
| Swinging force* N (kg, lb) | 9.12 - 91.30 (0.93 - 9.31; 2.05 - 20.53) | |
| Rotating torque N·m (kg-cm, in-lb) | 0.29 - 2.94 (3.0 - 30.0, 2.6 - 26.0) | |
| Axial end play mm (in) | 0.5 (0.020) | |
| Tie-rod inner ball joint | | |
| Swinging force* N (kg, lb) | 8.14 - 122.6 (0.83 - 12.5, 1.83 - 27.6) | |
| Rotating torque N·m (kg-cm, in-lb) | 7.4 (75, 65) or less | |
| Axial end play mm (in) | 0 (0) | |
| Tie-rod standard length "L" mm (in) | 174.8 (6.88) | |

*: Measuring point

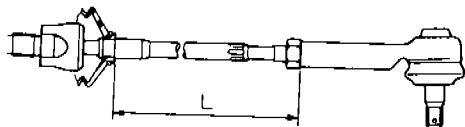

SST093B

| | | |
|-----------------------------------------------------|-----------------------------------------|--------------|
| Pinion gear preload (Average) N·m (kg-cm, in-lb) | 0.78 - 1.27 (8.0 - 13.0, 6.9 - 11.3) | |
| Rack stroke "L" mm (in) | 68.5 (2.697) | 66.0 (2.598) |

PR24SC

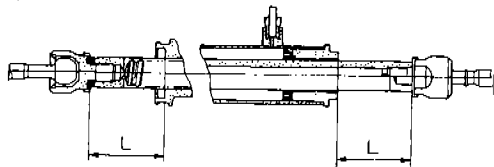

SST086B

PR26SC

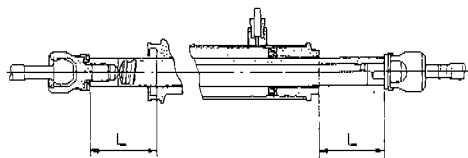

SST164B

POWER STEERING

| | |
|----------------------------------------------------------------------------------------|---------------------------------------------|
| Rack sliding force N (kg, lb) | 166.7 - 255.6 (17.0 - 23.0, 37.5 - 50.7) |
| Steering wheel turning force (Measured at one full turn from neutral) N (kg, lb) | 39 (4, 9) or less |
| Normal operating temperature of power steering fluid °C (°F) | 60 - 80 (140 - 176) |
| Fluid capacity (Approximate) ℓ (Imp qt) | 0.9 (3/4) |
| Oil pump maximum pressure kPa (bar, kg/cm ² , psi) | 6,865 (68.6, 70, 995) |

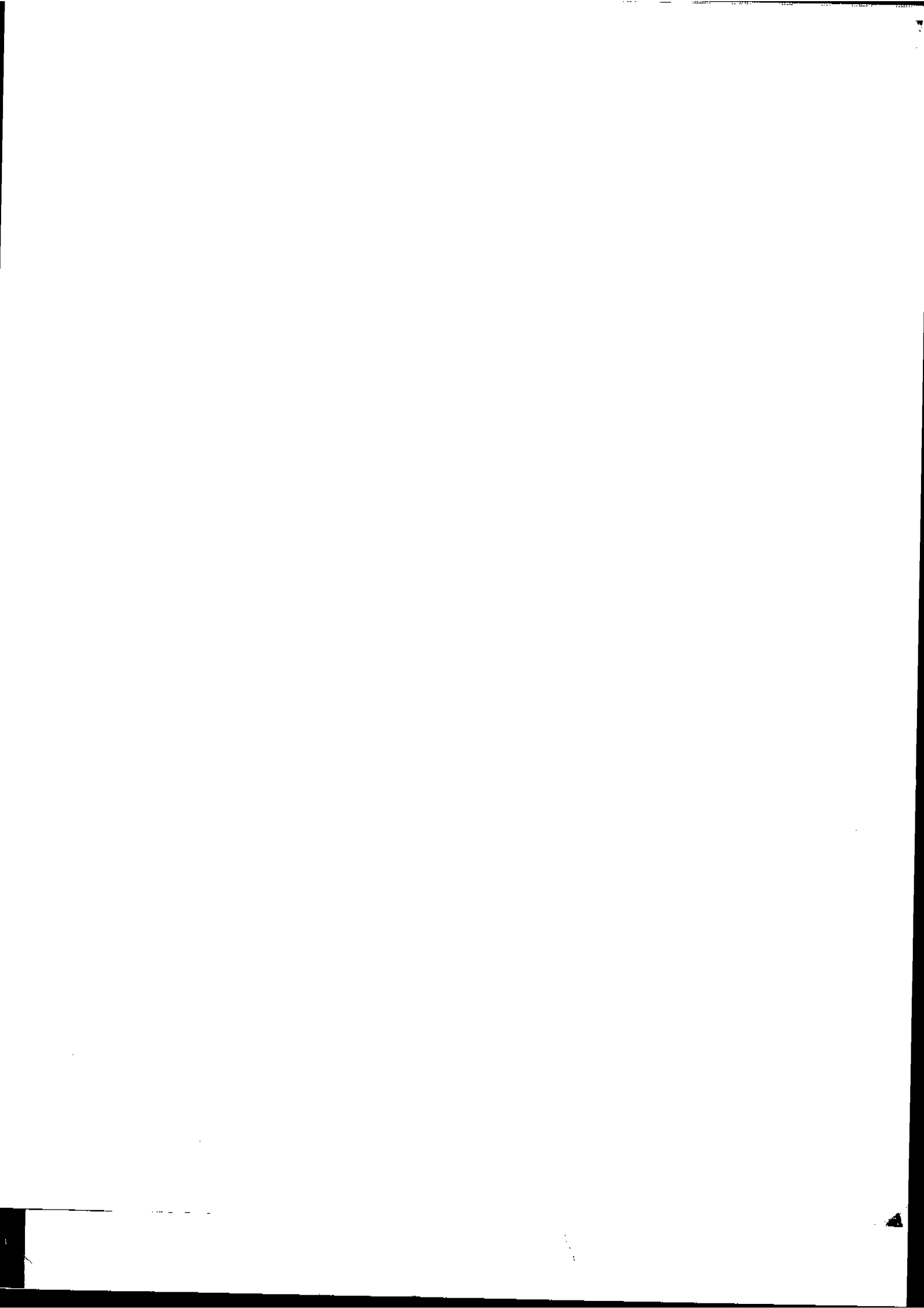

SECTION BF**CONTENTS**

| | |
|------------------------------------------------------|-------|
| GENERAL SERVICING | |
| (Including all clips & fasteners) | BF- 2 |
| BODY END | BF- 6 |
| DOOR | |
| (Including "Power Window" & "Power Door Lock") | BF-10 |
| INSTRUMENT PANEL | BF-16 |
| INTERIOR AND EXTERIOR | |
| (In EXTERIOR, including "Weatherstrips") | BF-18 |
| SEAT | BF-25 |
| SUN ROOF | BF-27 |
| WINDSHIELD AND WINDOWS | BF-28 |
| MIRROR | BF-33 |
| REAR COMBINATION LAMP | BF-34 |
| FRONT AND REAR AIR SPOILER | BF-35 |
| BODY ALIGNMENT | BF-36 |

When you read wiring diagrams:

- Read GI section, "HOW TO READ WIRING DIAGRAMS".
- See EL section, "POWER SUPPLY ROUTING" for power distribution circuit.

BF

★ For seat belt, refer to MA section.





GENERAL SERVICING

Precautions

- When removing or installing various parts, place a cloth or padding onto the vehicle body to prevent scratches.
- Handle trim, molding, instruments, grille, etc. carefully during removing or installation. Be careful not to soil or damage them.
- Apply sealing compound where necessary when installing parts.
- When applying sealing compound, be careful that the sealing compound does not protrude from parts.
- When replacing any metal parts (for example body outer panel, members, etc.), be sure to take rust prevention measures.

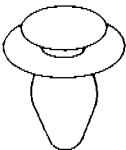
Clip and Fastener

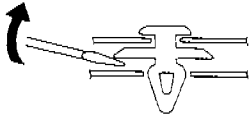
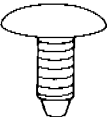
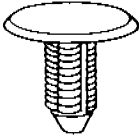
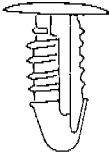
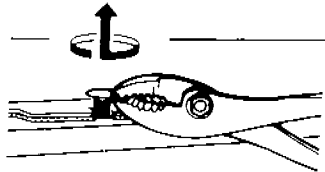
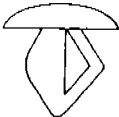
- Clips and fasteners in BF section correspond to the following numbers and symbols.
- Replace any clips and/or fasteners which are damaged during removal or installation.

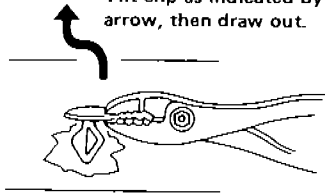
| No. | Symbol | Shape | Removal & Installation |
|------|------------------------------------------------------------------------------------------------|---------------------------------------------------------------------------------------------------------------------------------------------------------------------------------------------------|---------------------------------------------------------------------------------------------------------------------------------------------------------------------------|
| C101 |  SBF092B |  SBF109B | <p>Removal: Remove by bending up with a flat-bladed screwdriver.</p>  SBF094B |
| C102 |  SBF113B |  SBF114B  SBF137B |  <p>Removal: Pull up by rotating.</p> SBF115B |
| C105 |  SBF141B |  SBF142B | <p>Removal: Tilt clip as indicated by arrow, then draw out.</p>  SBF143B |

GENERAL SERVICING

Clip and Fastener (Cont'd)

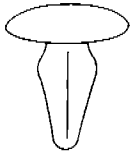
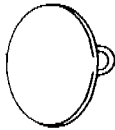
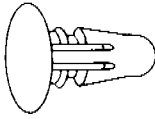
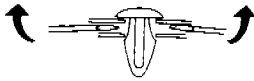
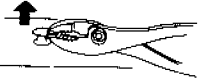
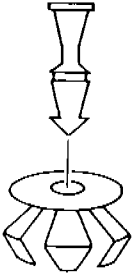
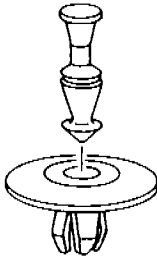
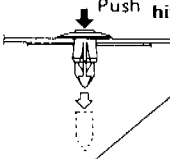
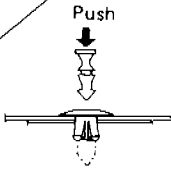
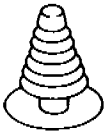
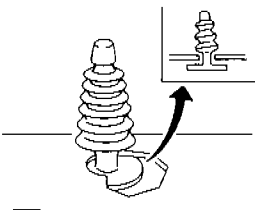
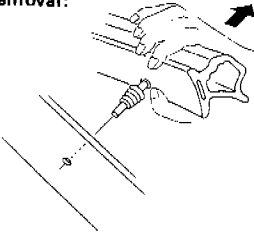
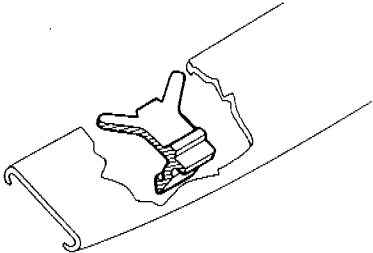
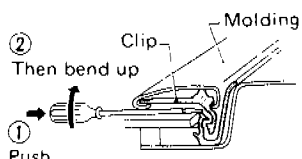
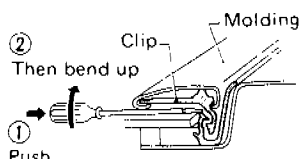
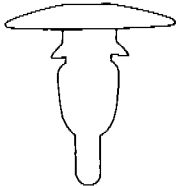
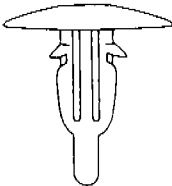
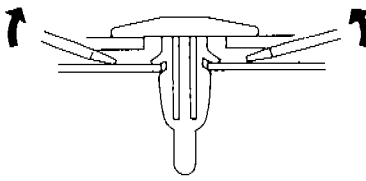
| No. | Symbol | Shape | Removal & Installation |
|-------|------------------------------------------------------------------------------------------------|------------------------------------------------------------------------------------------------------------------------------------------------------------------------------------|-------------------------------------------------------------------------------------------------------------------------------------------------------------------------------------------------------------------------------------------------------------------------------------------------------|
| C106 |  SBF089B |   SBF090B | <p>Removal: Remove with a flat-bladed screwdrivers or plier.</p>   SBF091B |
| C203 |  SBF318C |  SBF319C | <p>Installation:</p> <p>Push center pin to catching position. (Do not remove center pin by hitting it.)</p>   SBF320C |
| CE103 |  SBF103B |  SBF104B | <p>Removal:</p>  SBF147B |
| CE106 |  SBF653B |  SBF654B | <p>Removal:</p>  SBF654B |
| CE117 |  SBF173D |  SBF174D | <p>Removal: Remove with a flat-bladed screwdriver or pliers.</p>  SBF175D |

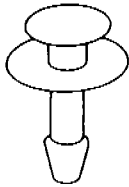
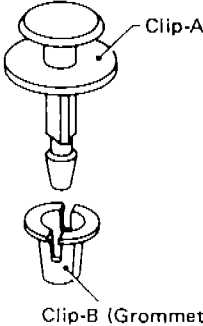
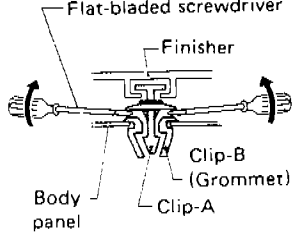
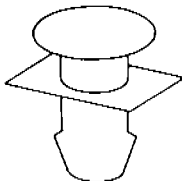
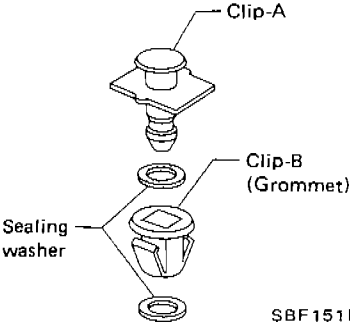
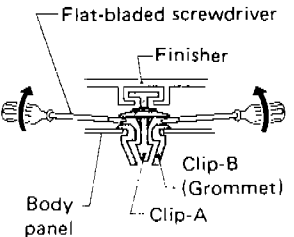
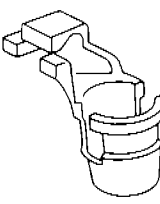
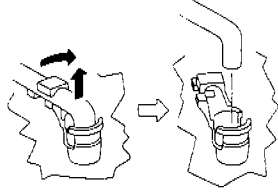
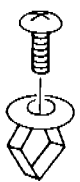
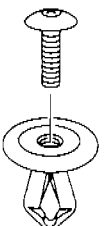
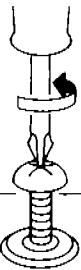
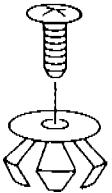
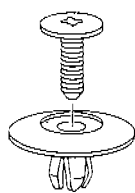

GENERAL SERVICING

Clip and Fastener (Cont'd)

| No. | Symbol | Shape | Removal & Installation |
|-------|------------------------------------------------------------------------------------------------|------------------------------------------------------------------------------------------------------------------|--------------------------------------------------------------------------------------------------------------------------------------------------------------------------------------|
| CF113 |  SBF035C |  SBF036C Clip-B (Grommet) | <p>Removal:</p>  SBF652B |
| CF118 |  SBF150D |  SBF151D Sealing washer | <p>Removal:</p>  SBF652B |
| CR103 | |  SBF768B | <p>Removal: Holder portion of clip must be spread out to remove rod.</p>  SBF770B |
| CS102 |  SBF138B |  SBF139B | <p>Removal: Screw out with a Phillips screwdriver.</p>  SBF140B |
| CS103 |  SBF363B |  SBF364B | |

GENERAL SERVICING

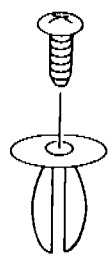
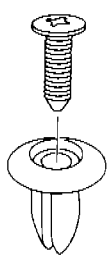
Clip and Fastener (Cont'd)

| No. | Symbol | Shape | Removal & Installation |
|-------|----------------------------------------------------------------------------------------------|----------------------------------------------------------------------------------------------|---------------------------------------------------------------------------------------------------------------------------------------------------------------|
| CS104 |  SBF361B |  SBF362B | <p>Removal: Screw out with a Phillips screwdriver.</p>  SBF140B |

BODY END

Body Front End

- Hood adjustment: Adjust at hinge portion.
- Hood lock adjustment: After adjusting, check hood lock control operation. Apply a coat of grease to hood locks engaging mechanism.
- Hood opener: Do not attempt to bend cable forcibly.

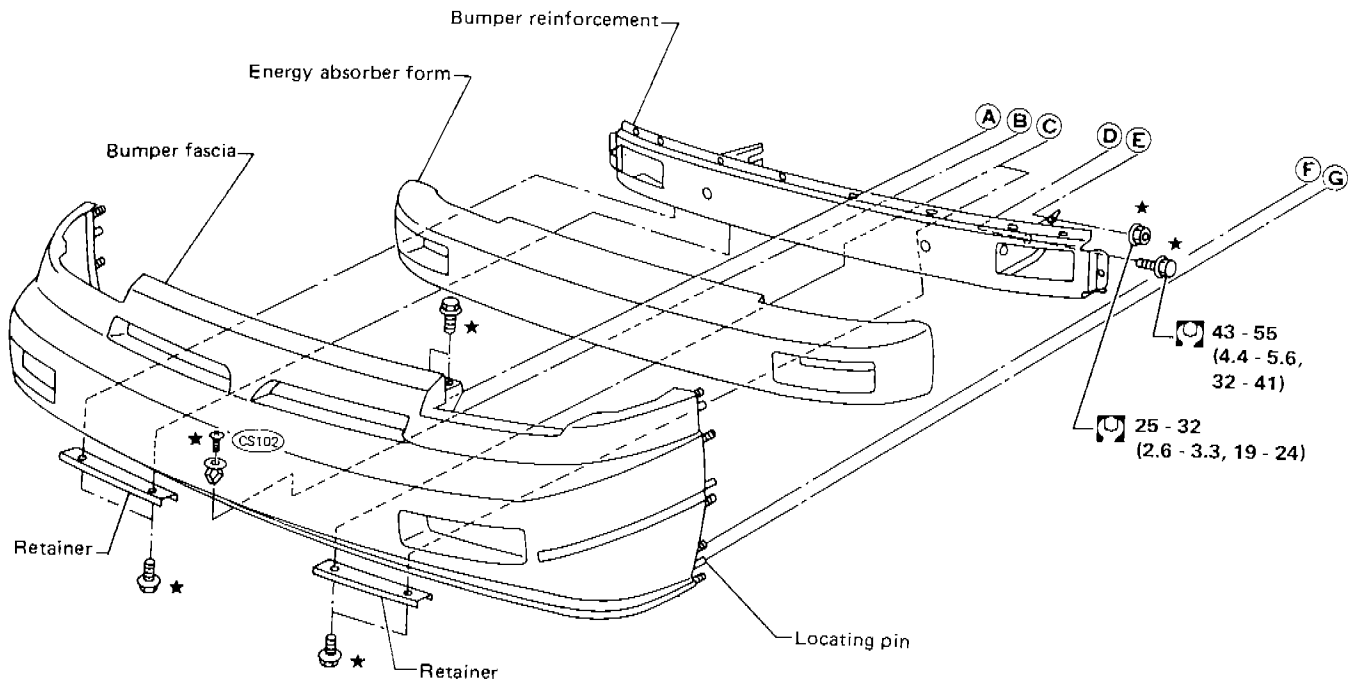

BODY END

Body Front End (Cont'd)

Hood lock adjustment

- Adjust lock so that hood primary lock meshes at a position where hood is 1 to 1.5 mm (0.039 to 0.059 in) lower than fender.
- After hood lock adjustment, adjust bumper rubber.
- When securing hood lock, ensure it does not tilt. Striker must be positioned at the center of hood primary lock.
- After adjustment, ensure that hood primary and secondary lock operate properly.

Hood lock secondary latch hooking length

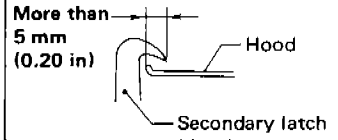

Bumper rubber adjustment

- Adjust so that hood is aligned with fender. [Bumper rubber free height is approx. 20 mm (0.79 in).]

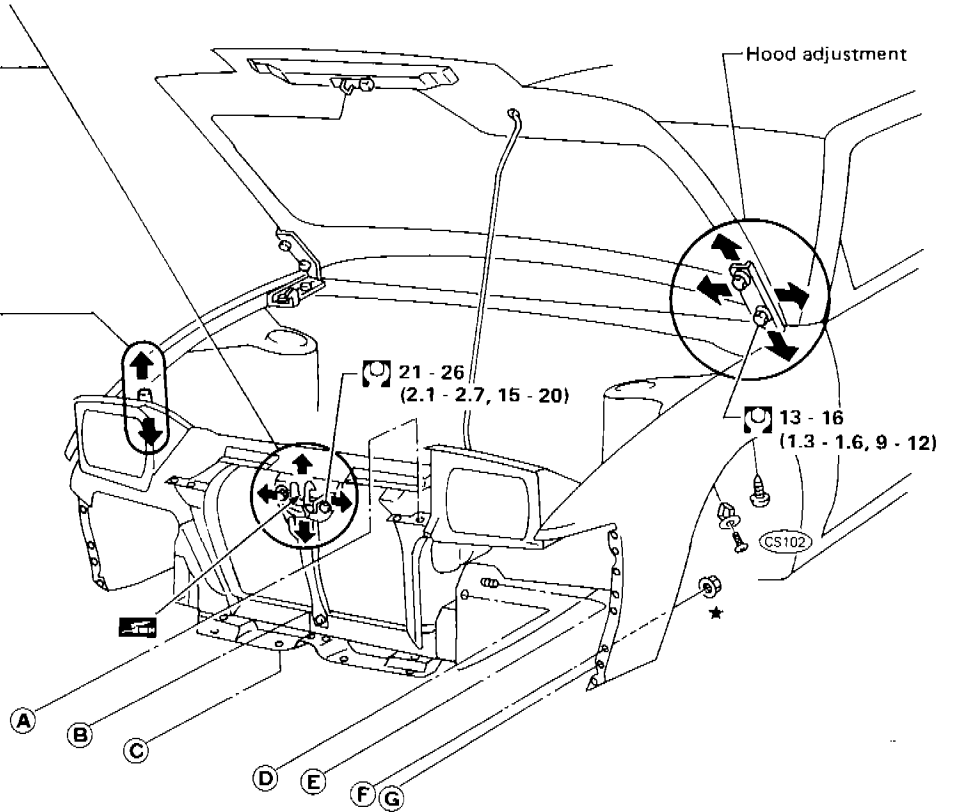

- ★ : Bumper assembly mounting bolts and nuts
- ☺ : N.m (kg-m, ft-lb)

SBF385E

BODY END

Body Rear End and Opener

- Back door adjustment: Adjust at hinge-body portion for proper back door fit.
- Back door lock system adjustment: Adjust lock & striker so that they are in the center. After adjustment, check back door lock operation.
- Trunk lid adjustment: Adjust at hinge-trunk lid portion for proper trunk lid fit.
- Trunk lid lock system adjustment: Adjust striker so that it is in the center of the lock. After adjustment, check trunk lid lock operation.

WARNING:

- Be careful not to scratch back door stay when installing back door. A scratched stay may cause gas leakage.**
 - The contents of the back door stay are under pressure. Do not take apart, puncture, apply heat or allow fire near it.**
- Opener cable: do not attempt to bend cable using excessive force.
 - After installation, make sure that trunk lid/back door and fuel filler lid open smoothly.
 - Before removing rear bumper, remove right drafter which is secured with two upper nuts and butyl seal.

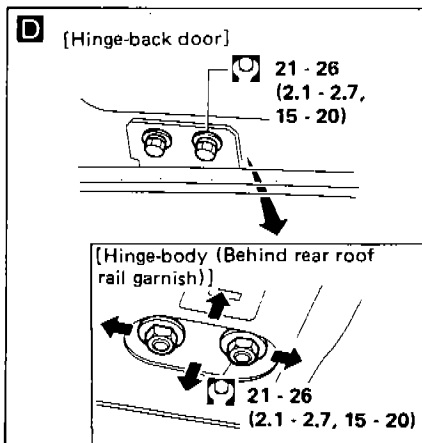
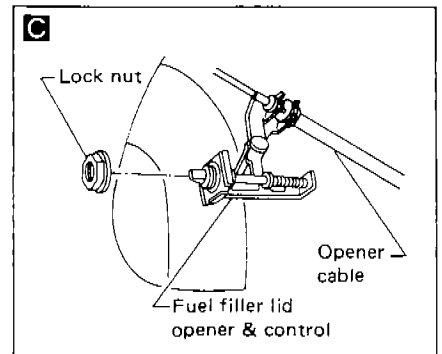
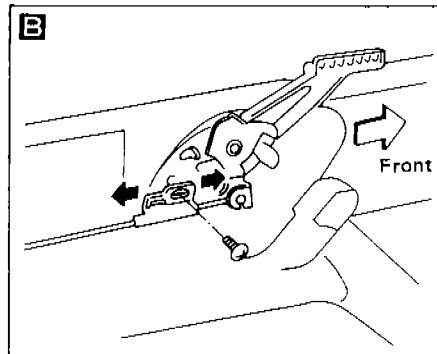
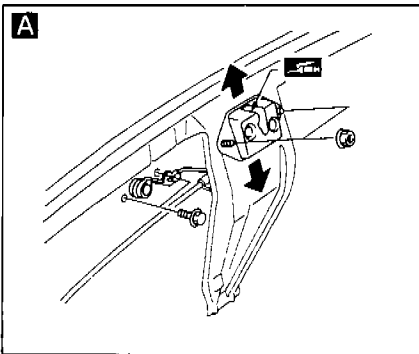

BODY END

Body Rear End and Opener (Cont'd)

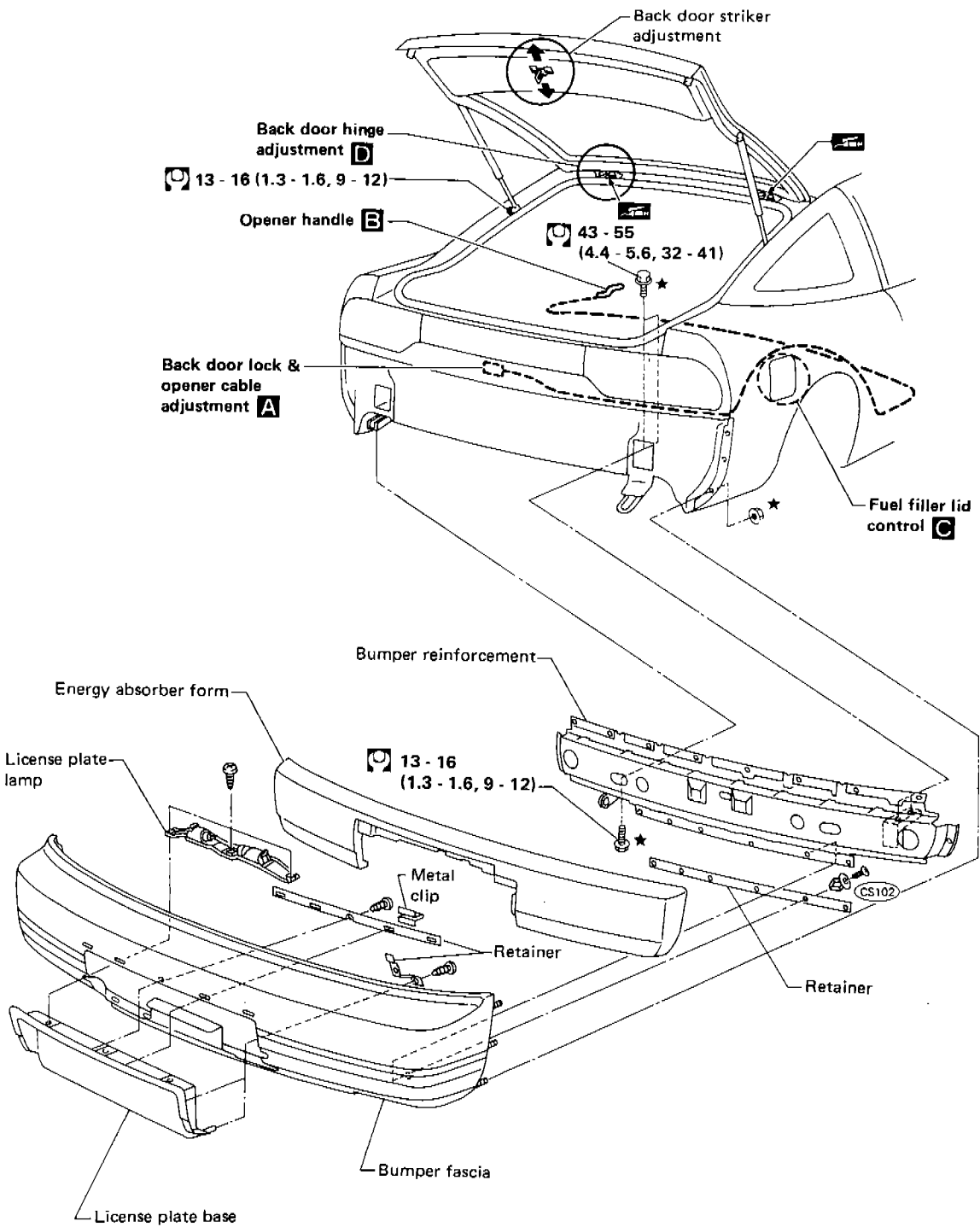

★ : Bumper assembly mounting bolts and nuts

⊙ : N·m (kg·m, ft·lb)

SBF376E

DOOR

- After adjusting door or door lock, check door lock operation.

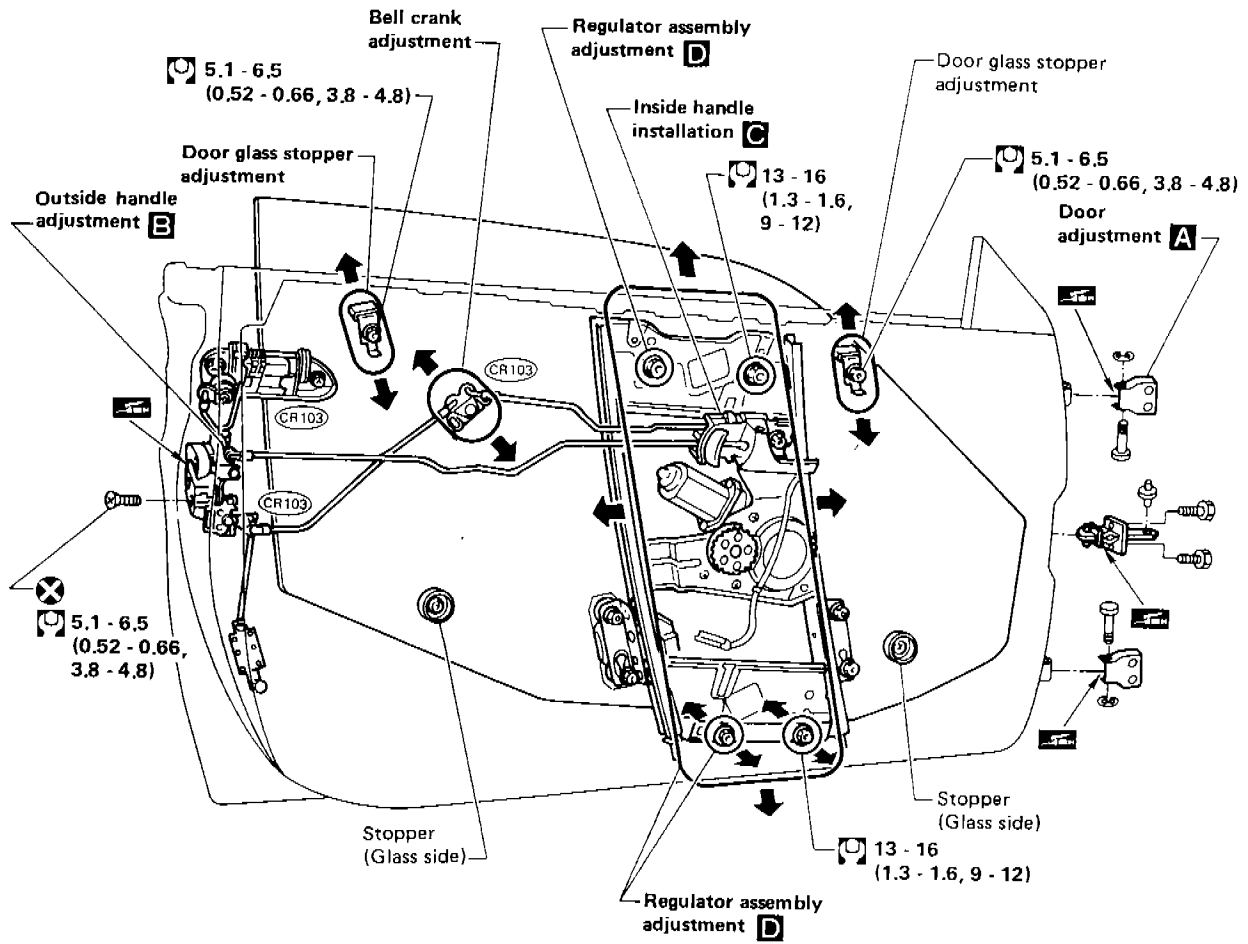

: N·m (kg·m, ft·lb)

DOOR

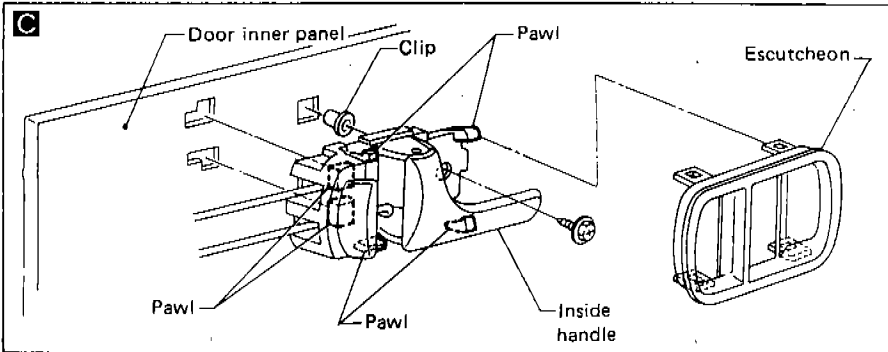
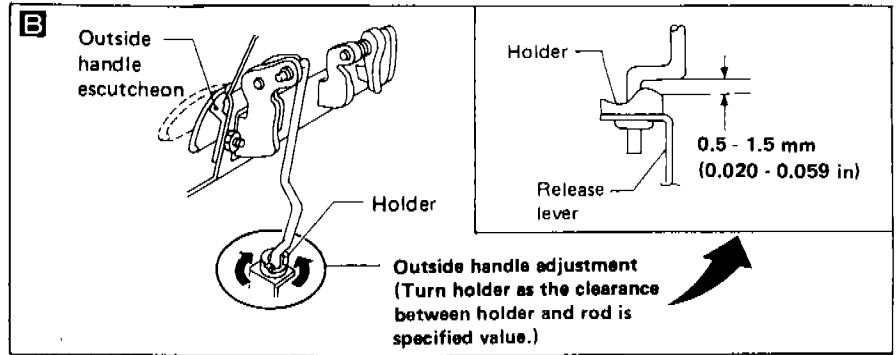
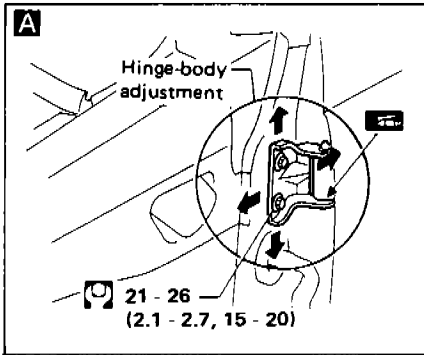

Striker adjustment

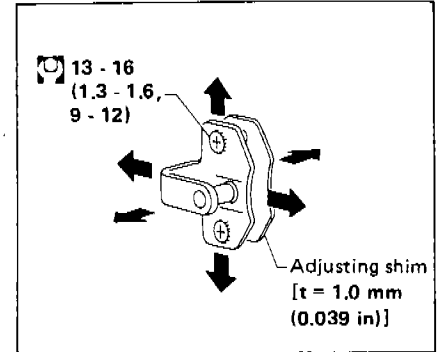

- D**
- Remove weatherstrip from retainer.

- Door glass-to-retainer clearances A and B
Adjust so that clearances A and B are equal.
- Ensure door glass is not tilted.

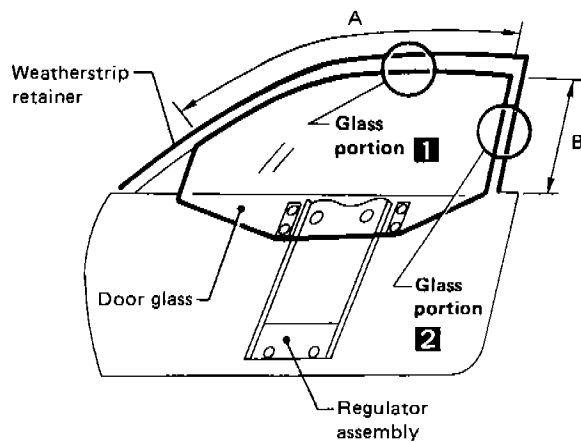

Glass portion 1

- Adjust to provide proper light surface contact of glass and retainer.

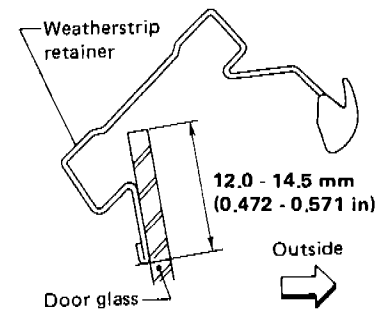

Glass portion 2

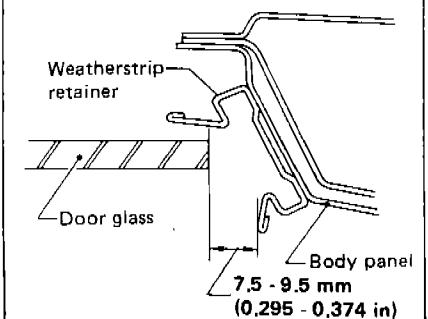

SBF177E

DOOR

Power Window (Cont'd)

POWER WINDOW AMP. INSPECTION

POWER WINDOW TIMER RELAY SYSTEM

- When ignition switch ON or ST, this system is ON.

FRONT DRIVER SIDE POWER WINDOW SWITCH

| Connections | FR Drive side | | | | | | |
|-------------|------------------|---|---|--------|---|---|--------------------------|
| | One-touch (Auto) | | | Manual | | | |
| | U | N | D | U | N | D | |
| 1 | ○ | ○ | ○ | ○ | ○ | ○ | From power window AMP, ④ |
| 2 | ○ | ○ | ○ | ○ | ○ | ○ | From power window AMP, ⑤ |
| 3 | ○ | ○ | ○ | ○ | ○ | ○ | From power window AMP, ⑥ |
| 4 | ○ | ○ | ○ | ○ | ○ | ○ | Ground |

Window operating direction

| | | |
|----------|---|------------------------|
| Upward | ↖ | Current flow direction |
| Downward | ↗ | |

AMP. OPERATION

| Connections | Operations | | | | | | | | |
|-----------------------------------------------------|------------------|-----------------|-----------------|----------------------------|-----------------|-----------------|-----------------|-----------------|-----------------|
| | Manual operation | | | One-touch (Auto) Operation | | | | | |
| | 12V | 12V | 12V | 12V | 12V | 12V | 12V | 12V | 12V |
| 51 Power source (IGN) | Ground | Ground | Ground | Ground | Ground | Ground | Ground | Ground | Ground |
| 52 | ON or ST | ON or ST | ON or ST | ON or ST | ON or ST | ON or ST | ON or ST | ON or ST | ON or ST |
| 53 | OFF | OFF | OFF | OFF | ON | OFF | ON | OFF | OFF |
| 54 To FR driver side power window SW (AUTO) ① | OFF | ON | OFF | OFF | ON | OFF | OFF | OFF | OFF |
| 55 To FR driver side power window SW (UP) ③ | OFF | OFF | ON | OFF | OFF | OFF | ON | OFF | OFF |
| 56 To FR driver side power window SW (DOWN) ② | OFF | OFF | OFF | ON | OFF | OFF | OFF | ON | OFF |
| 57 FR driver side regulator (Upward power source) | Approx. 0V | Approx. over 9V | Approx. 0V | Approx. 0V | Approx. over 9V | Approx. over 9V | Approx. over 9V | Approx. 0V | Approx. 0V |
| 58 FR driver side regulator (Downward power source) | Approx. 0V | Approx. 0V | Approx. over 9V | Approx. 0V | Approx. 0V | Approx. 0V | Approx. 0V | Approx. over 9V | Approx. over 9V |

| Regulator Operating Condition | Stop | Upward operation | Downward operation | Stop | Starting | Keeping operation until fully closed, then stops automatically. | Starting | Keeping operation until fully open, then stops automatically. |
|-------------------------------|------|------------------|--------------------|------|------------------|-----------------------------------------------------------------|--------------------|---------------------------------------------------------------|
| | | | | | Upward operation | | Downward operation | |

Carry out this operation check in this chart from left to right continuously.

POWER WINDOW AMP. – Front driver side door (Behind door trim)

SBF392E

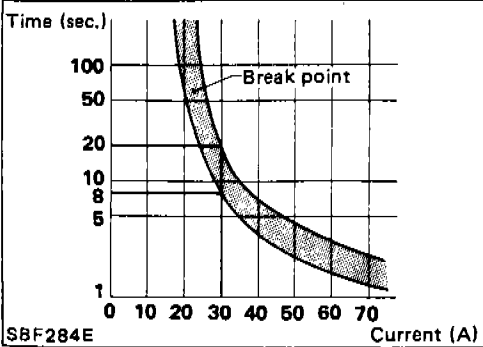

CIRCUIT BREAKER INSPECTION

For example, when current is 30A, the circuit is broken within 8 to 20 seconds.

This circuit breaker is also used in the power door lock system.

DOOR

Power Door Lock

WIRING DIAGRAM

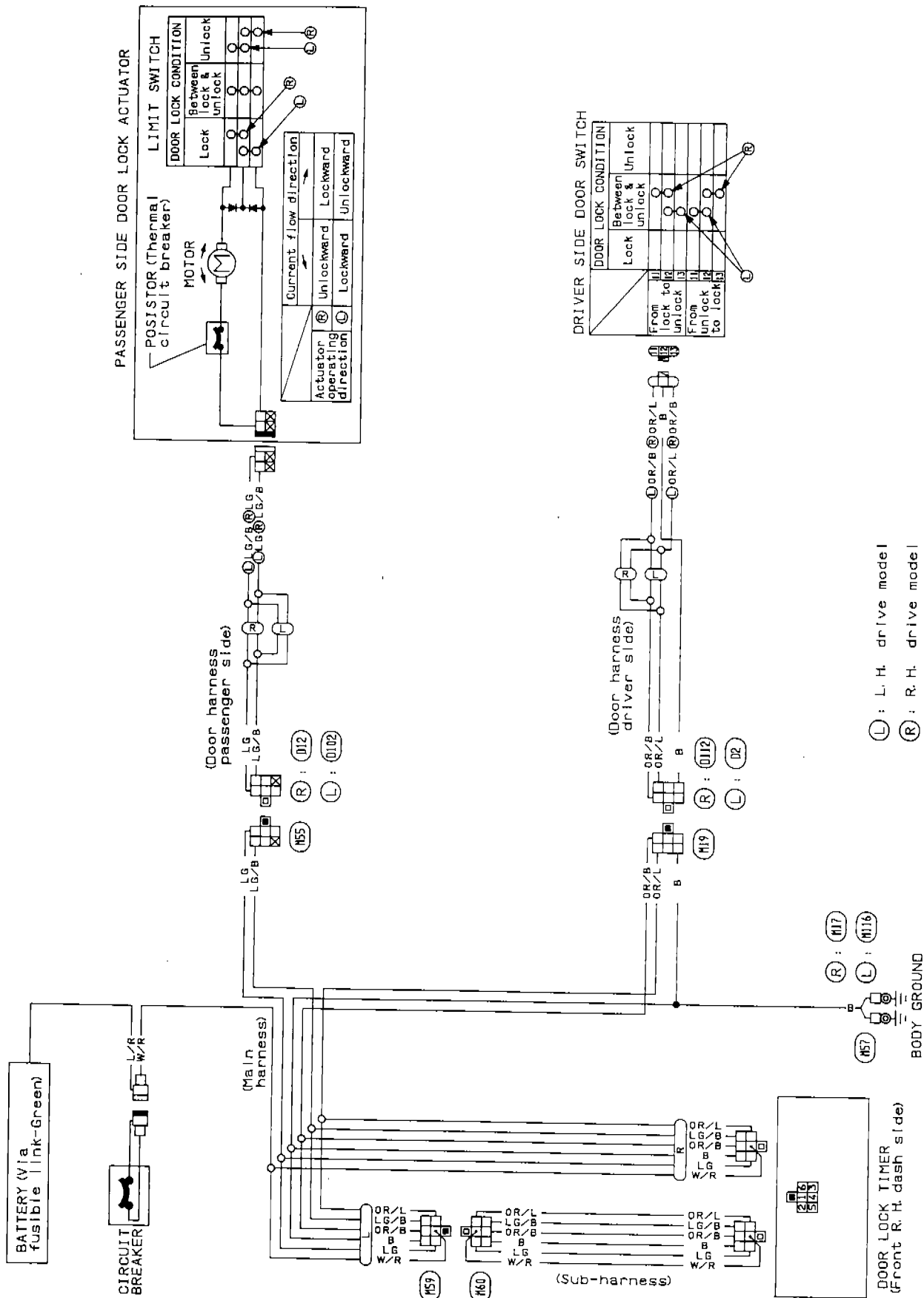

DOOR

Power Door Lock (Cont'd)

DOOR LOCK TIMER INSPECTION

TESTING OPERATION

| | | | | | | | | | | |
|---------------|---------------------|-----|-----------------------------|-----|-----------|-----------------------------|-----|-----------|--------------------------------------------|-----------|
| Input signal | SW-A operation | OFF | Turns ON | ON | Turns OFF | OFF | OFF | OFF | Turns ON | Turns OFF |
| | SW-B operation | OFF | OFF | OFF | OFF | Turns ON | ON | Turns OFF | After SW-A operation, immediately turns ON | Turns OFF |
| Output signal | Test lamp operation | OFF | ON (Approx. 1.0 sec.) → OFF | OFF | OFF | ON (Approx. 1.0 sec.) → OFF | OFF | OFF | ON → OFF → ON → OFF | OFF |

- Carry out the complete inspection in this chart from left to right.
- Do not carry out any switch operations that are not described in the above chart so as to avoid breaking the door lock timer.

Lighting period of test lamp differs according to SW-B operation. Moreover, test lamp may come on once or it may not come on at all. If this occurs, do not judge it faulty solely from this step.

INSPECTION CIRCUIT (This test circuit must be wired by the technician.)

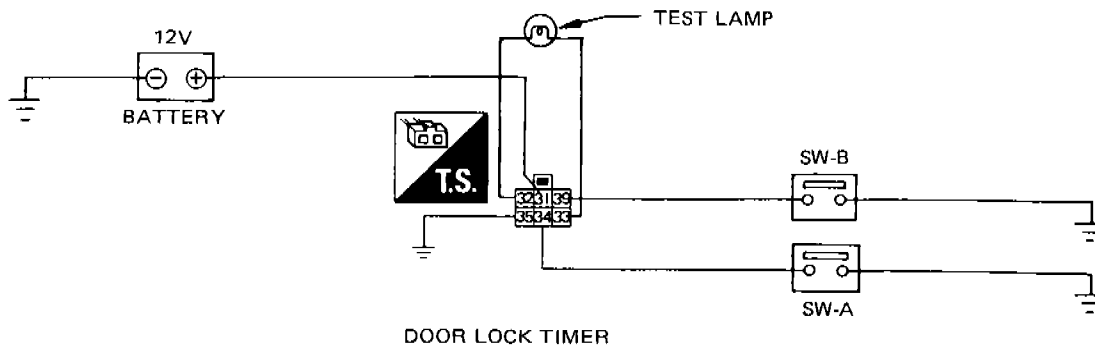

DOOR LOCK TIMER

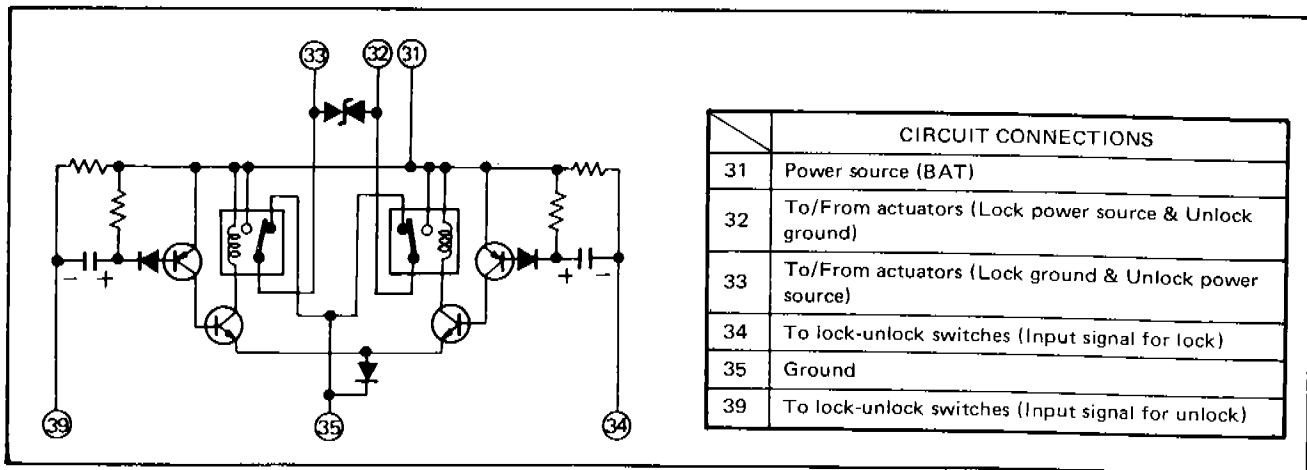

SBF393E

INSTRUMENT PANEL

- When removing instrument panel assembly, remove defroster grille, combination meter, A/C or heater control, cluster lid C and S.M.J. first.

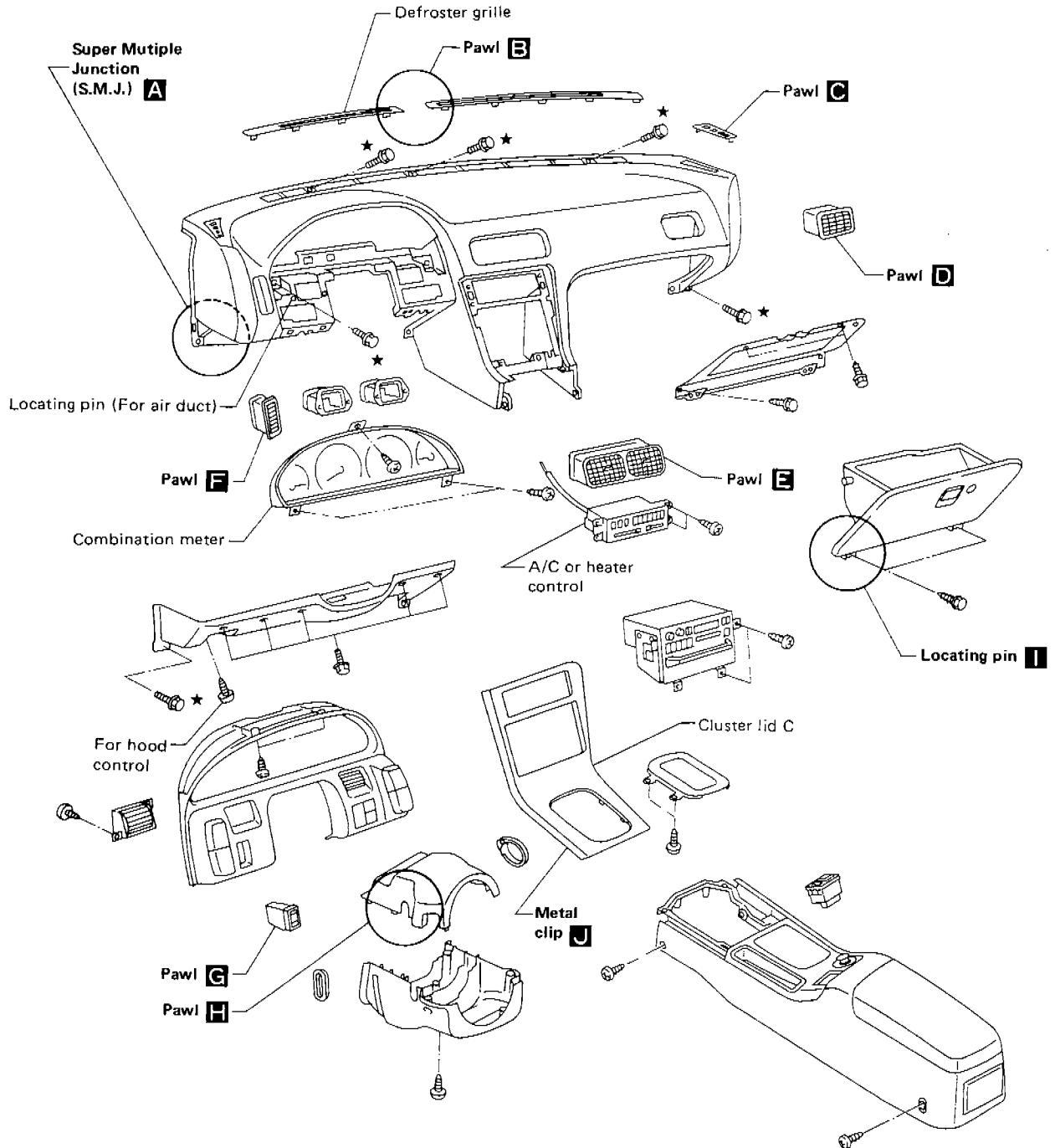

★ : Instrument panel assembly mounting bolts

INSTRUMENT PANEL

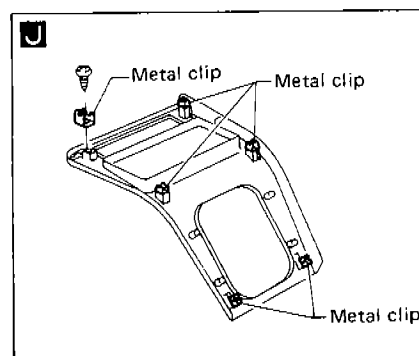
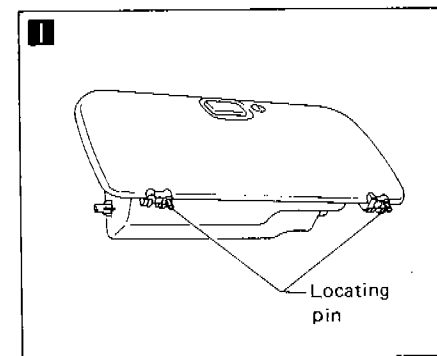
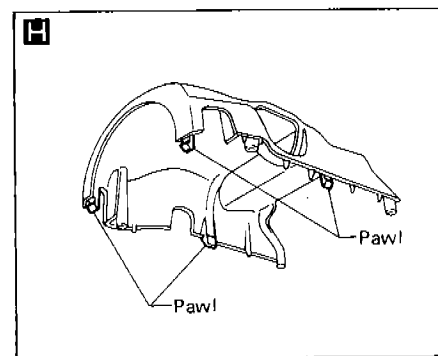
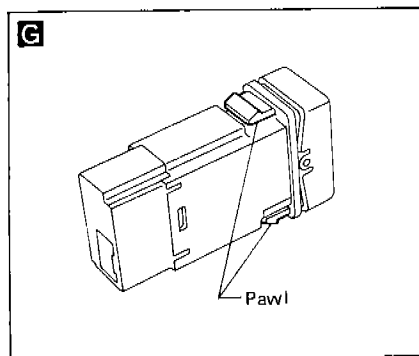
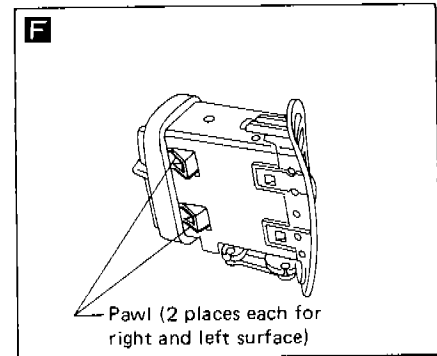
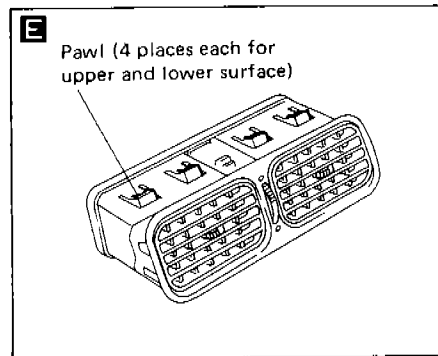
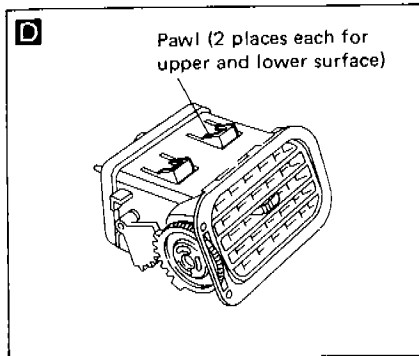
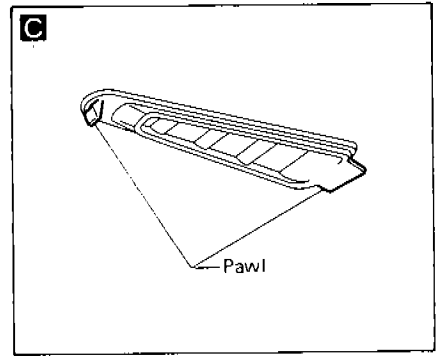
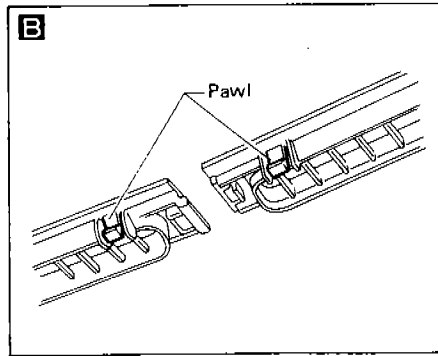
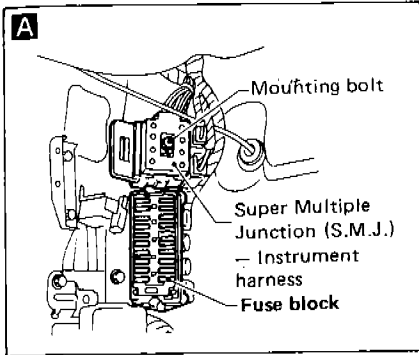

INTERIOR AND EXTERIOR

Interior

SIDE, LUGGAGE AND FLOOR TRIM

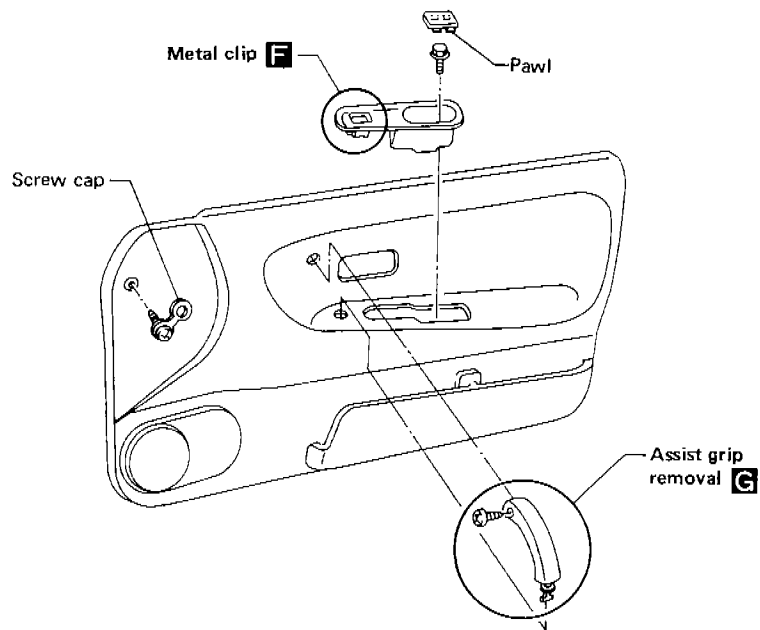
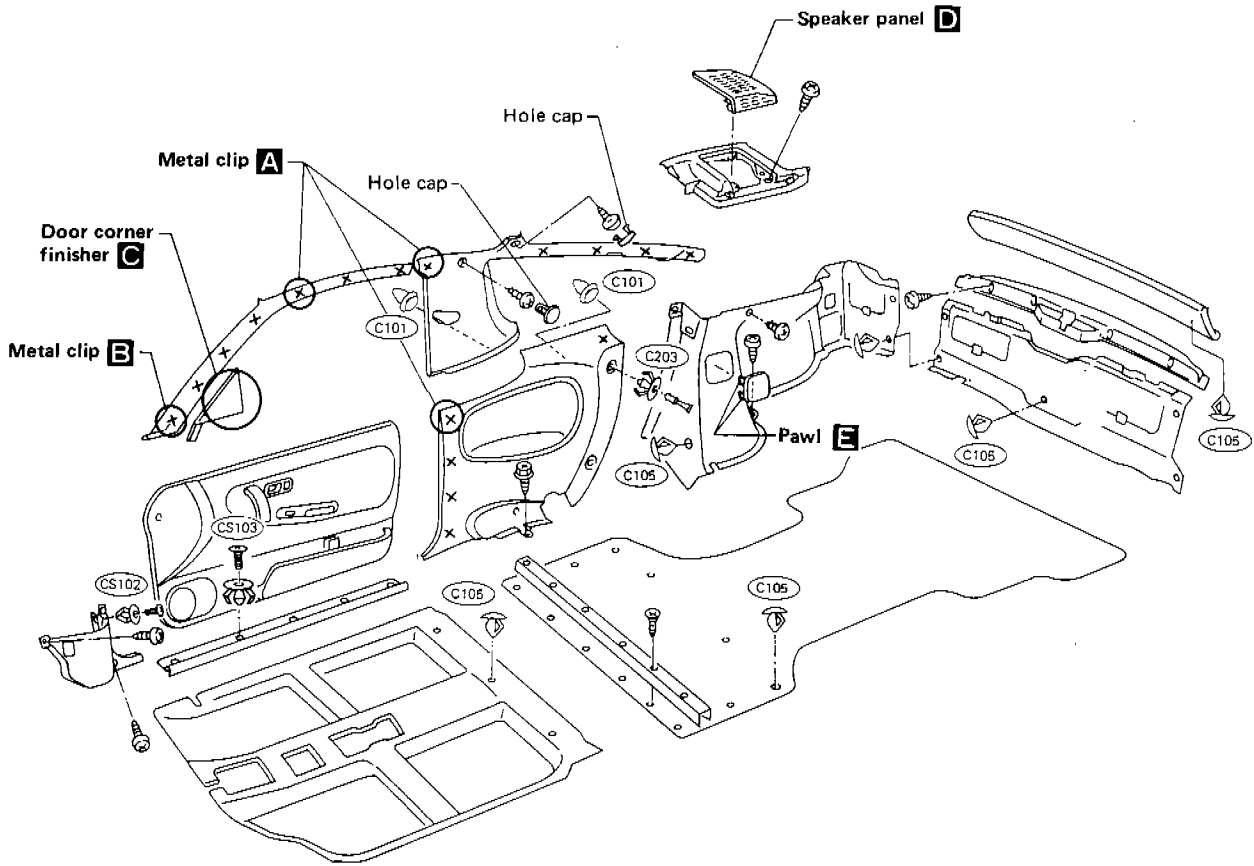

INTERIOR AND EXTERIOR

Interior (Cont'd)

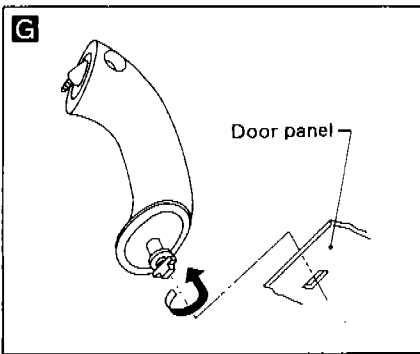
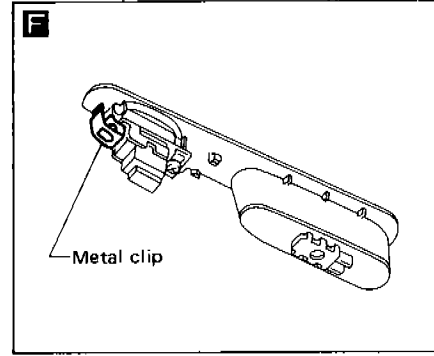
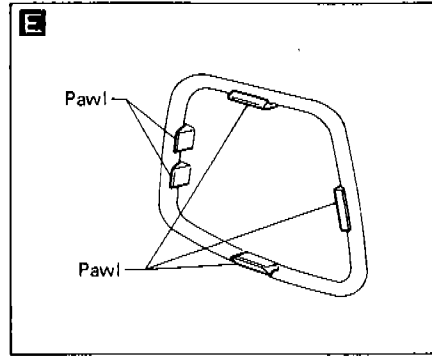
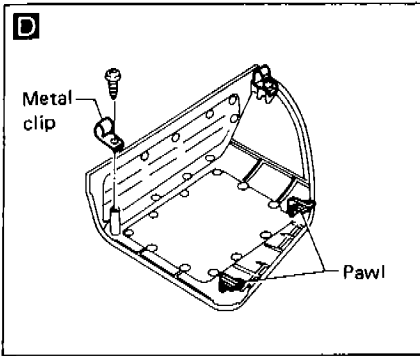
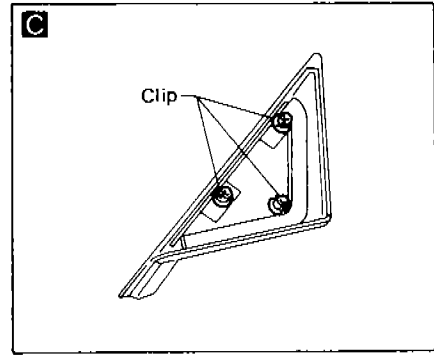
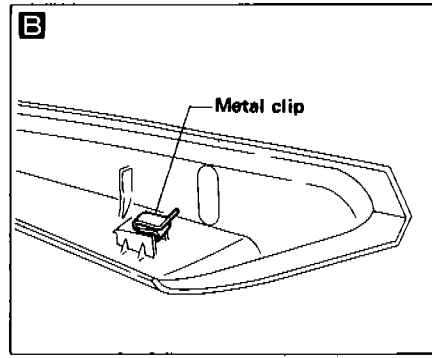
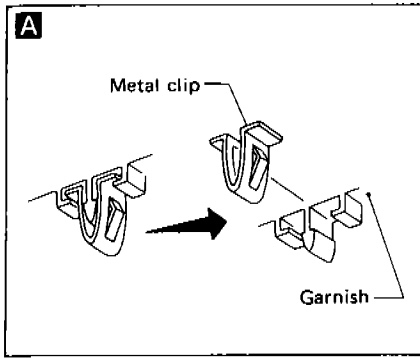

INTERIOR AND EXTERIOR

Interior (Cont'd)

ROOF TRIM

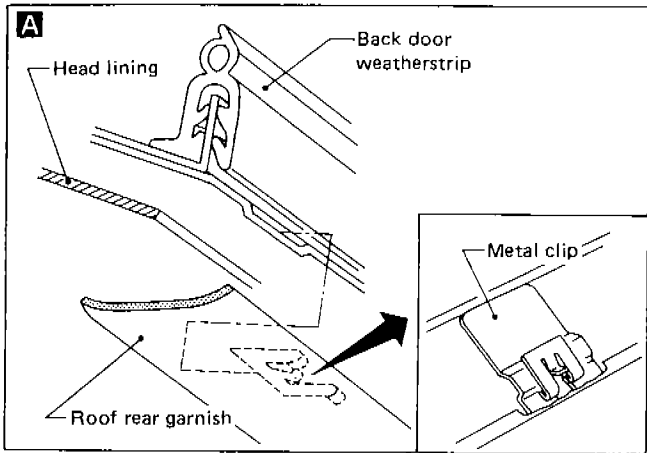
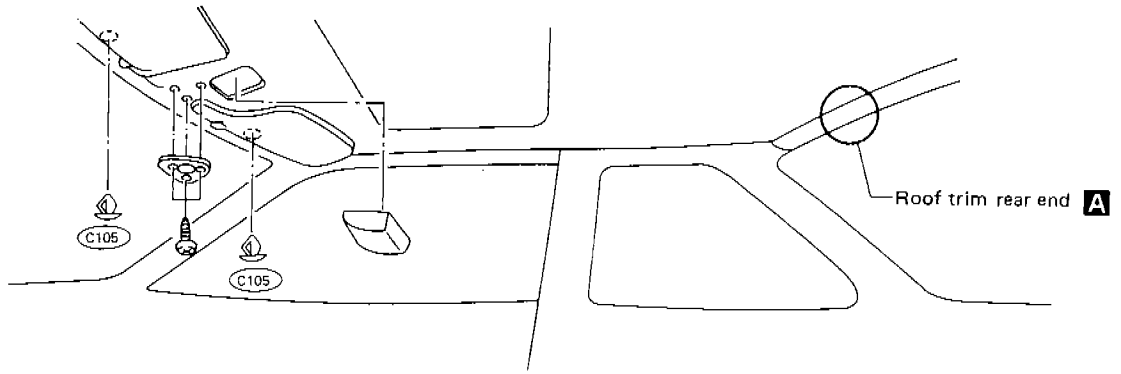

SBF387E

INTERIOR AND EXTERIOR

Exterior

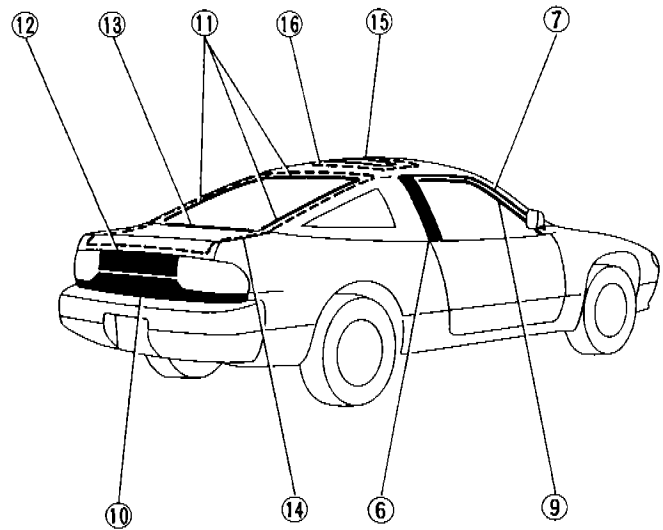
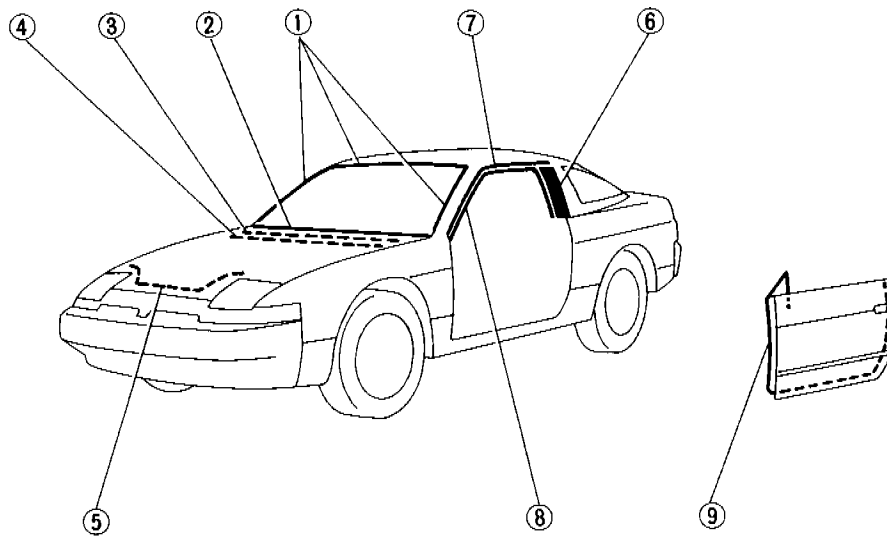

SBF388E

INTERIOR AND EXTERIOR

Exterior (Cont'd)

① Windshield upper and side molding

Method 1

Cut off top portion of molding and clean glass and panel surfaces.

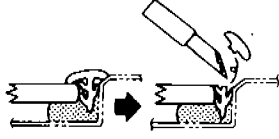

Apply sealant to top portion of molding.

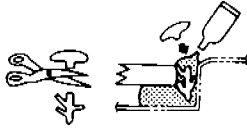

Cut off lower portion of new molding.



Finish well to give it a good appearance.

Method 2

1. Cut off sealant at glass end.
2. Clean the side on which panel was mounted.
3. Set molding fastener and apply sealant & primer to body panel, and apply primer to molding.

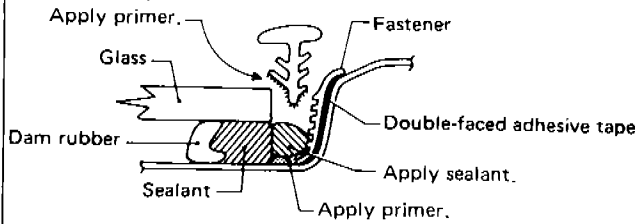

4. Install molding by aligning the molding mark located on center with vehicle center. Be sure to install tightly so that there is no gap around the corner.

SBF519B

- ### ② Windshield lower molding
- It is mounted with screws.

③, ④ Cowl top grille and hood rear sealing rubber

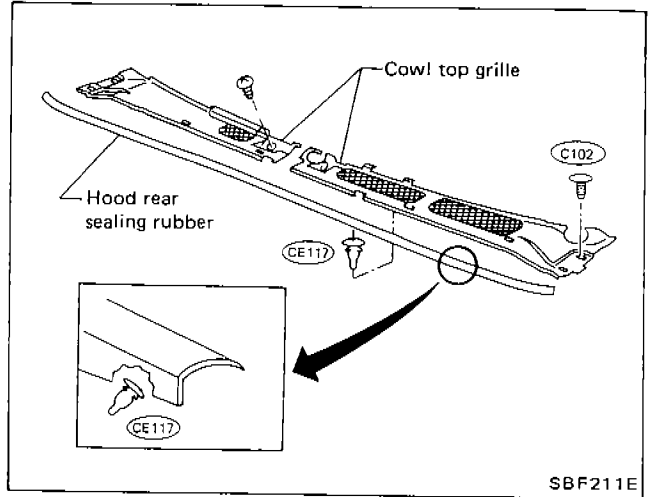

SBF211E

⑤ Hood front sealing rubber

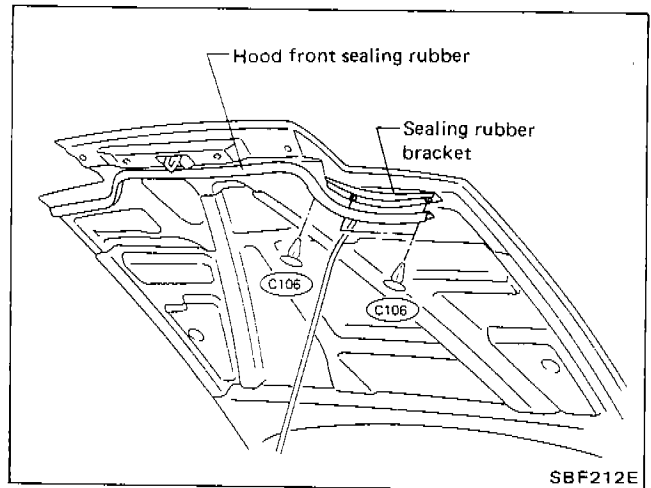

SBF212E

⑥ Center pillar finisher

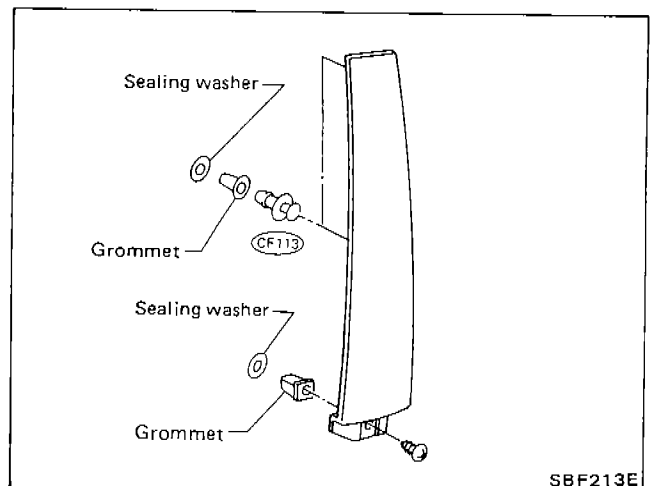

SBF213E

INTERIOR AND EXTERIOR

Exterior (Cont'd)

⑦, ⑧ Body side weatherstrip and weatherstrip retainer

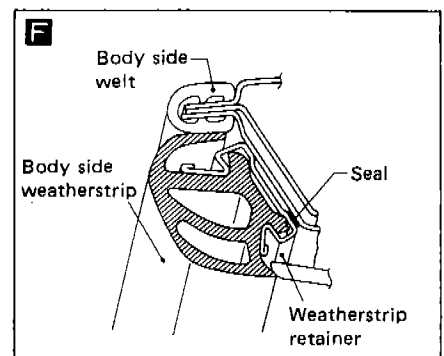
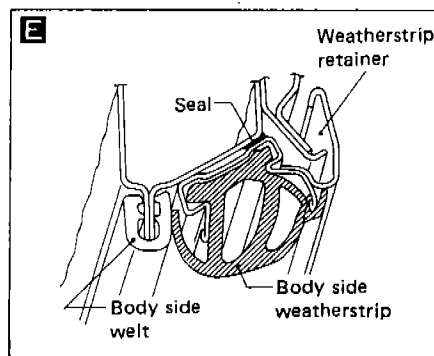
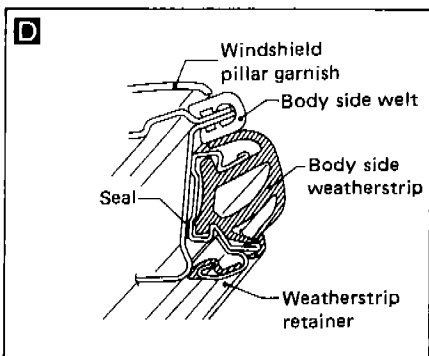
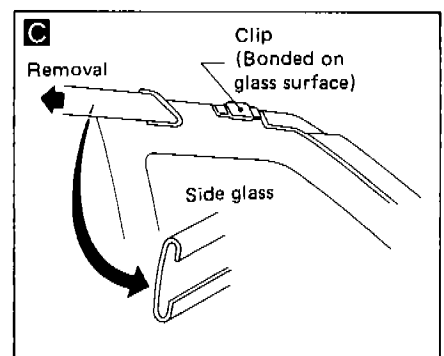
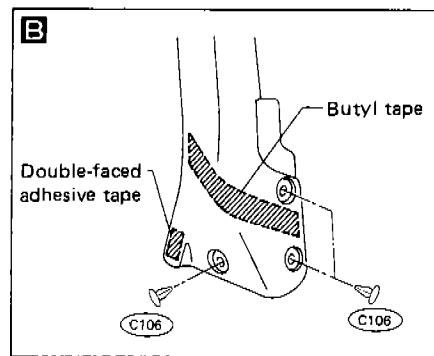
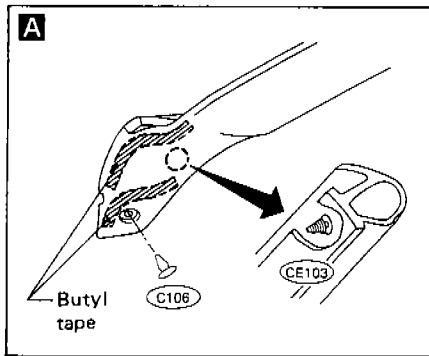
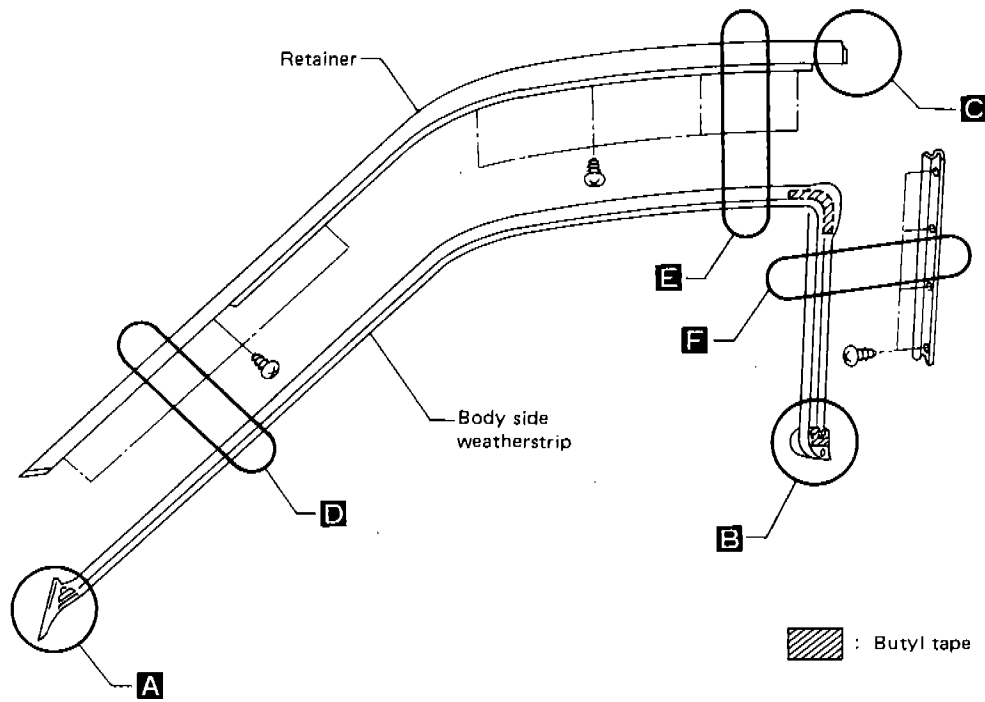

SBF214E

INTERIOR AND EXTERIOR

Exterior (Cont'd)

9 Door weatherstrip

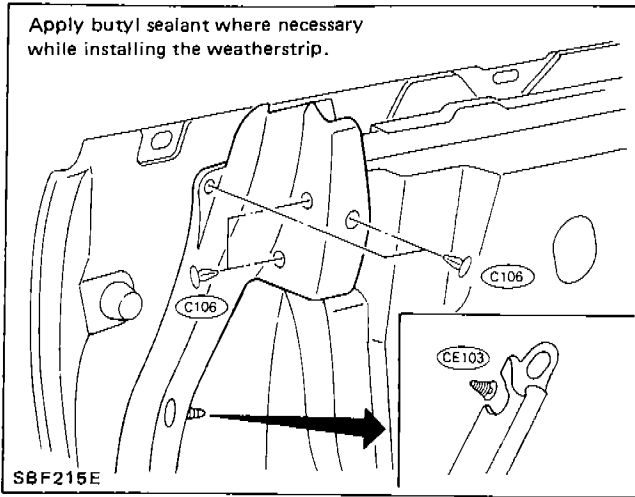

10 Rear sight shield

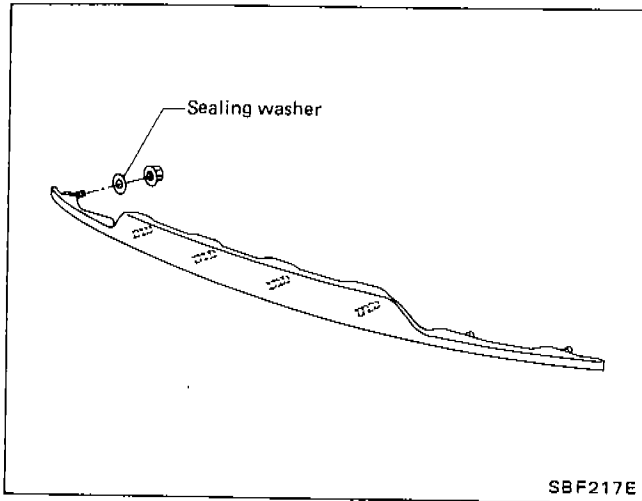

11 Back door window upper and side molding

Bonded on back door glass side.

12 Rear panel finisher

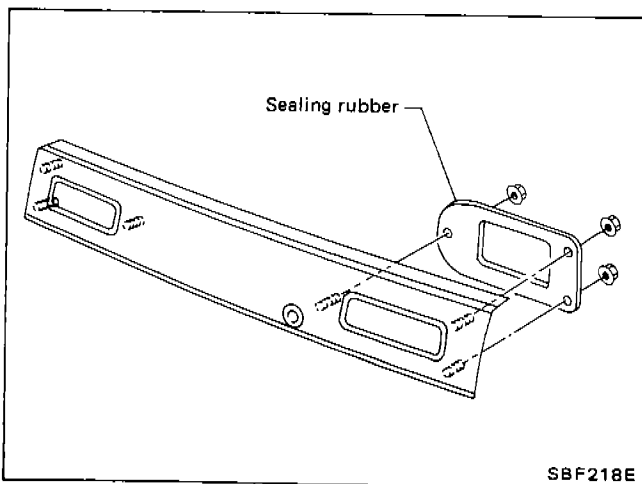

13 Back door window lower molding

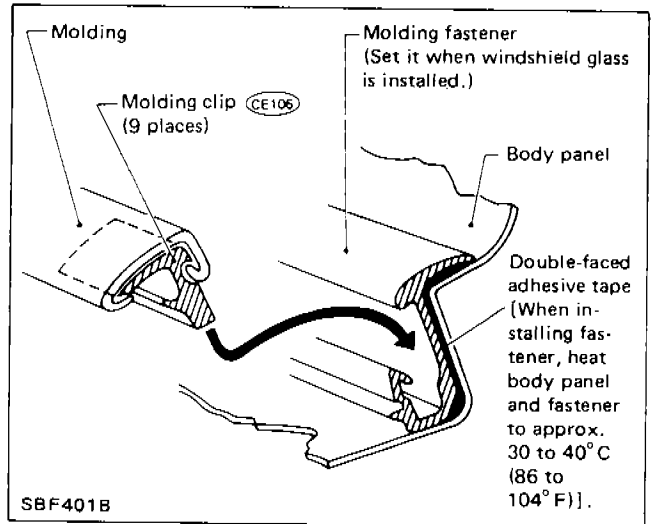

14 Back door weatherstrip

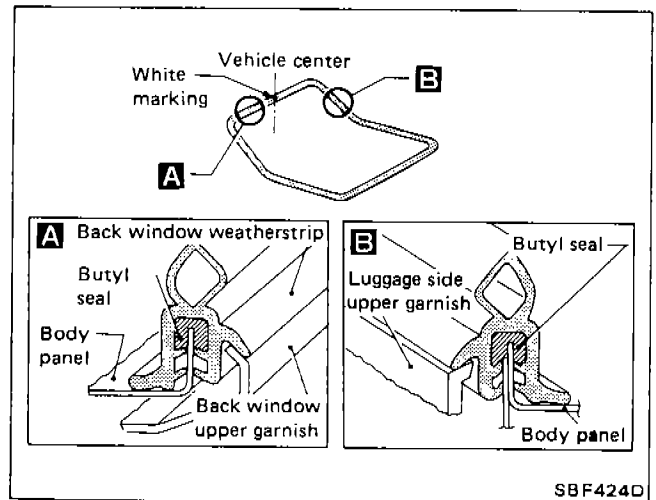

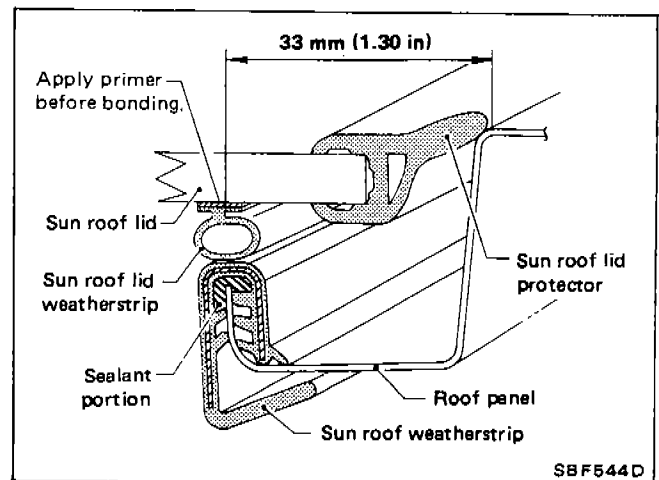

15 16 Sun roof weatherstrip & lid weatherstrip

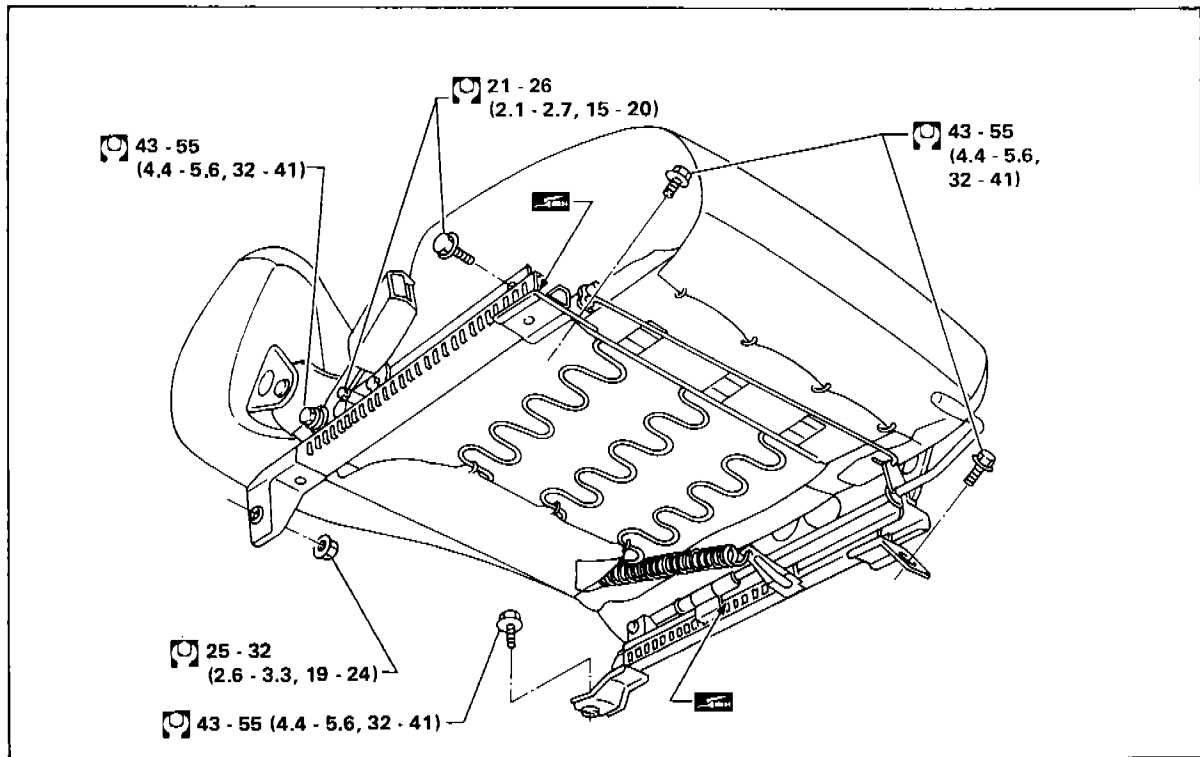
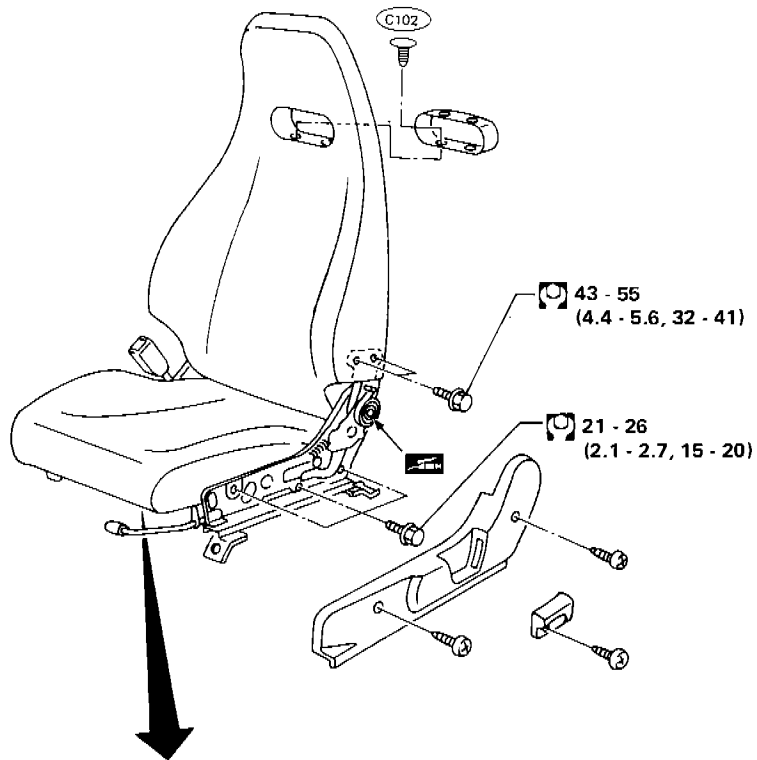

SEAT

Front Seat



 : N-m (kg-m, ft-lb)

SBF183E

BF-25

SEAT

Rear Seat

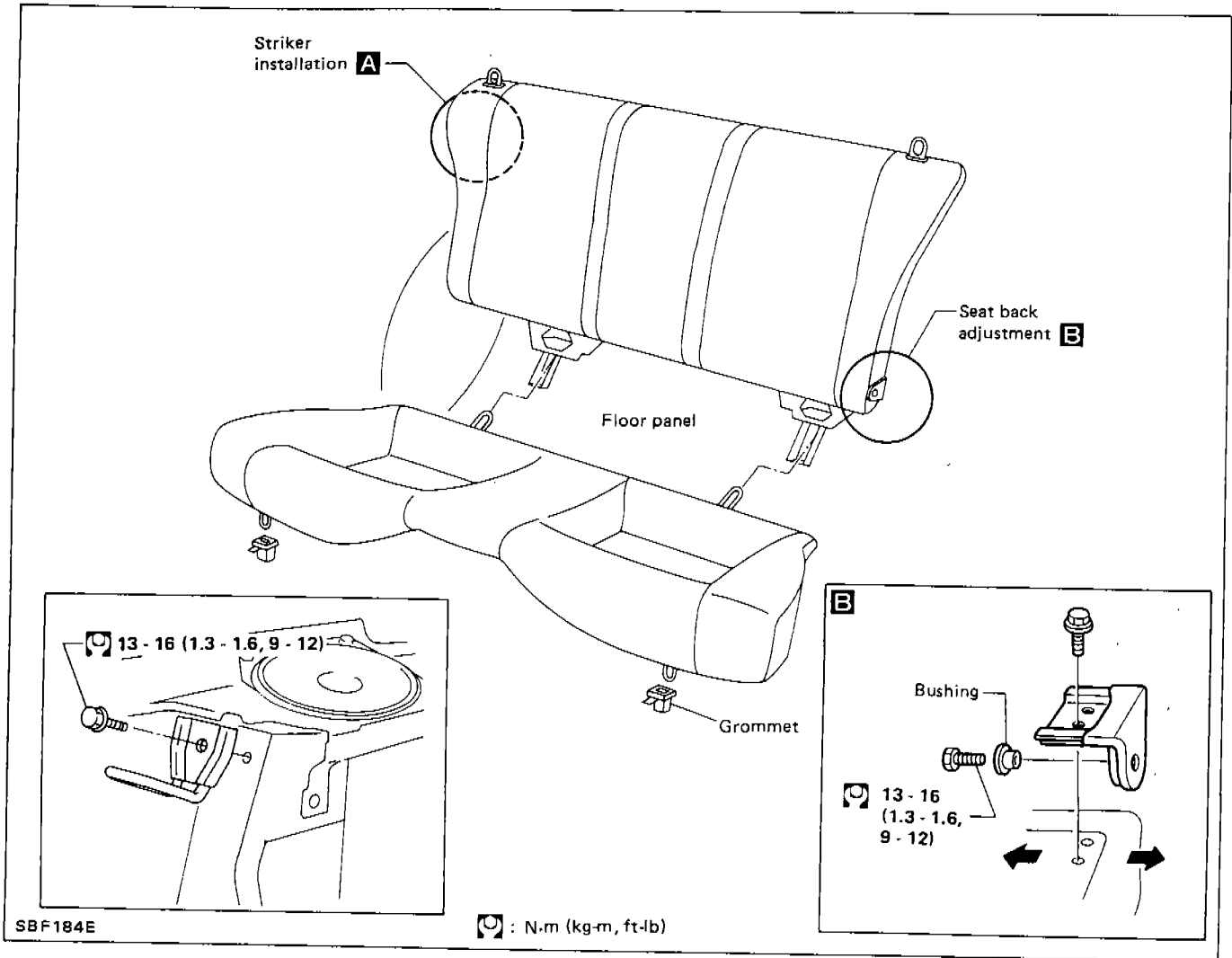

SUN ROOF

Handle adjustment

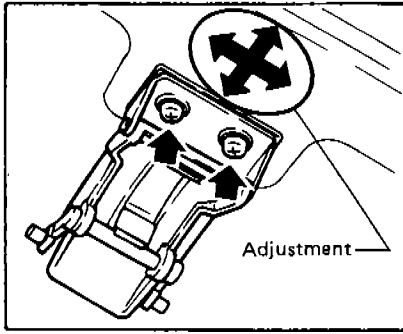

Female hinge

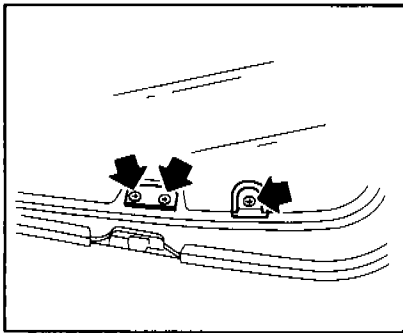

Hinge bracket

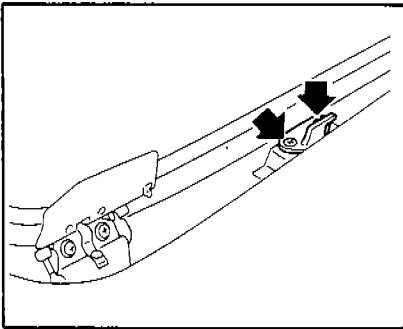

Air deflector adjustment

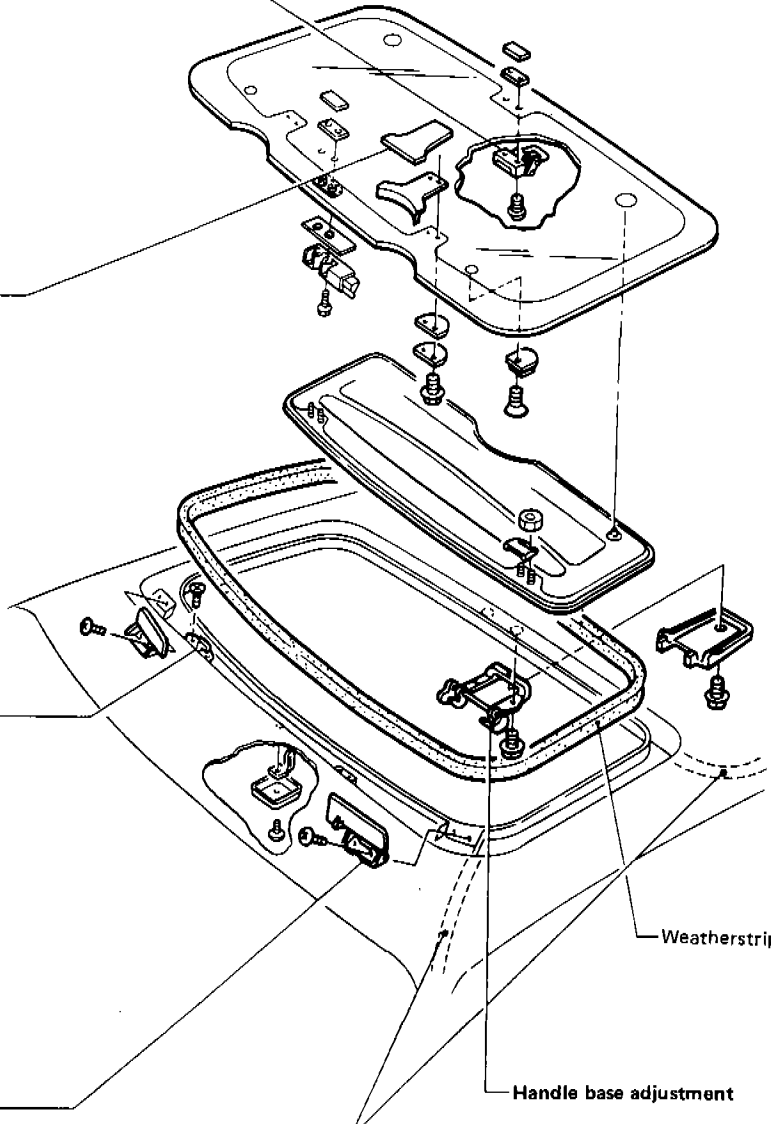
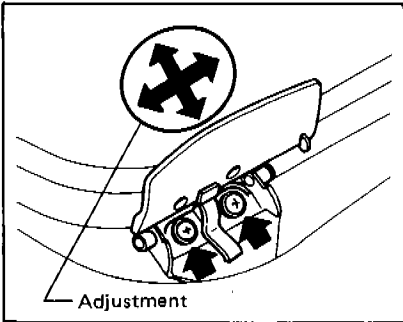

Weatherstrip

Handle base adjustment

Drain hose

- After installation of drain hoses, make sure water drains smoothly.

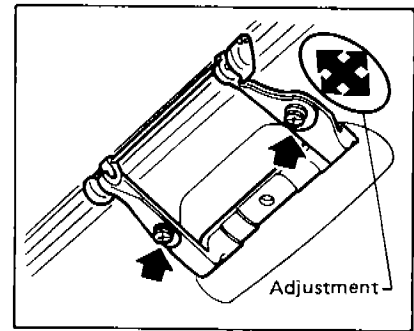

SBF186E

WINDSHIELD AND WINDOWS

Windshield

REMOVAL

After removing moldings, remove glass.

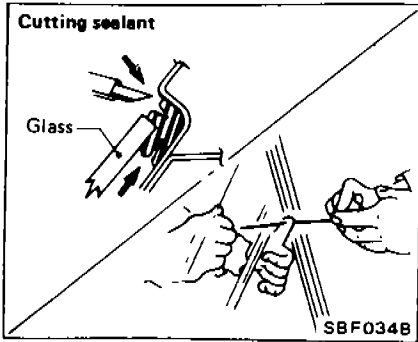

CAUTION:

Be careful not to scratch glass when removing.

INSTALLATION

- Use genuine Nissan Sealant kit or equivalent. Follow instructions furnished with it.
- After installation, the vehicle should remain stationary for about 24 hours.
- Do not use sealant which is more than 12 months past its production date.
- Do not leave cartridge unattended with its cap open.
- Keep primers and sealant in a cool, dry place. Nissan recommends that they are stored in a refrigerator.
- Be sure to install moldings.

WARNING:

Keep heat or open flames away as primers are flammable.

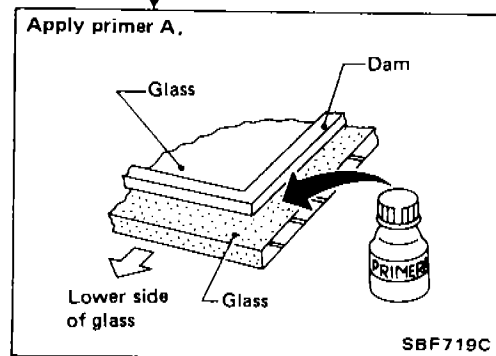
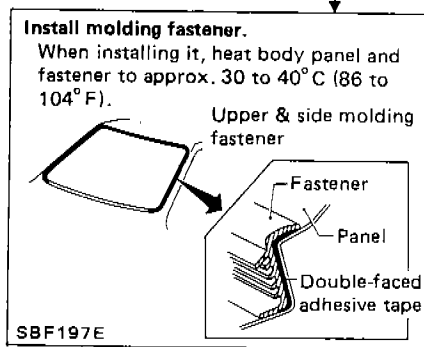
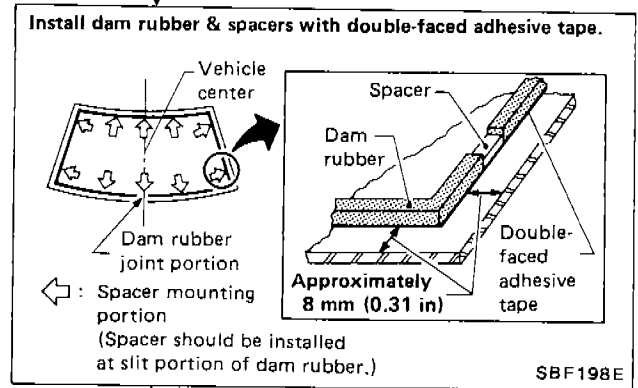
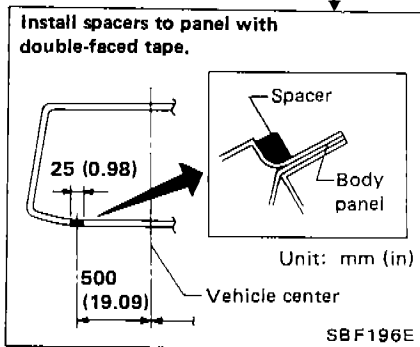
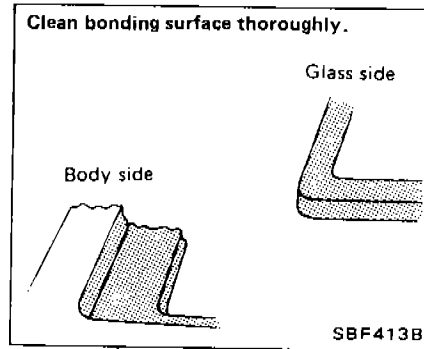

CAUTION:

Allow primers to dry for 10 to 15 minutes before proceeding to the next step.

A

B

WINDSHIELD AND WINDOWS

Windshield (Cont'd)

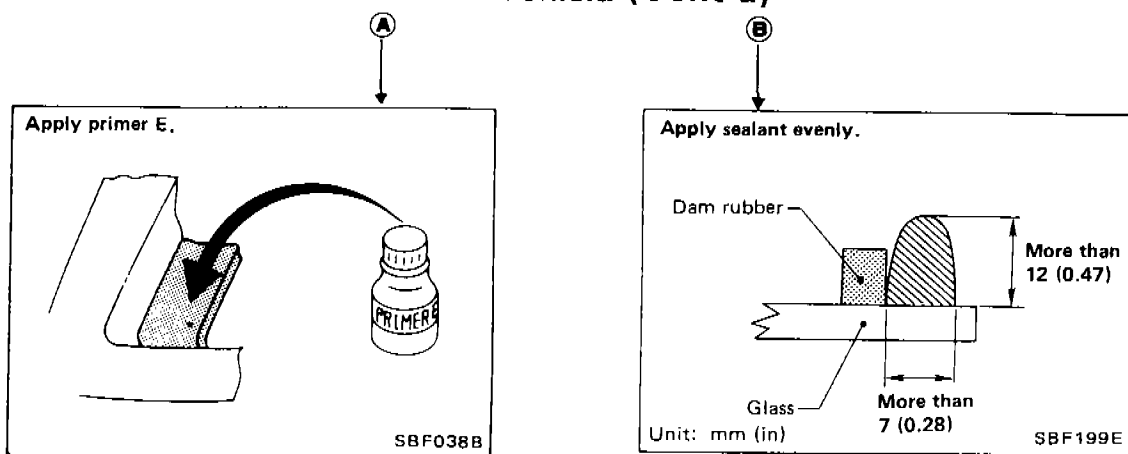

CAUTION:
Allow primers to dry for 10 to 15 minutes before proceeding to the next step.

CAUTION:
Windshield glass should be installed within 15 minutes of applying sealant: sealant starts to harden 15 minutes after it is applied.

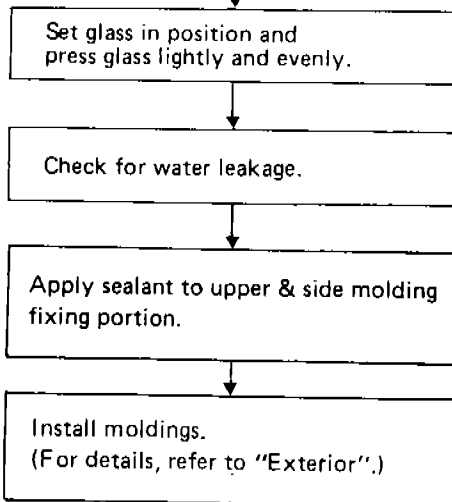

CAUTION:
For sealant drying time, refer to "Drying Time for Sealant".

CAUTION:
Molding must be installed securely so that it is in position and leaves no gap.

WINDSHIELD AND WINDOWS

Back Door Window

- Construction and removal/reinstallation method of back door window are basically the same as those of windshield.
- Major differences are that sealant & dam rubber are installed to back door panel instead of glass surface. Spacer position is also changed. Moreover, there are locating pins in lower portion of glass. For details, refer to following figure.
- For sealant drying period, refer to "Drying Time for Sealant".
- For details of moldings, refer to "Exterior".

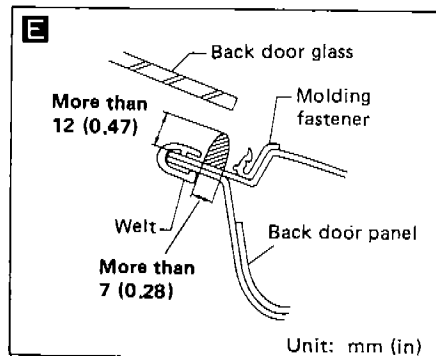
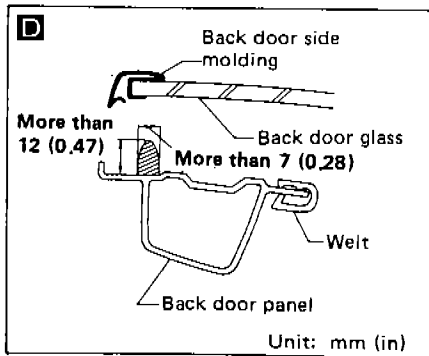
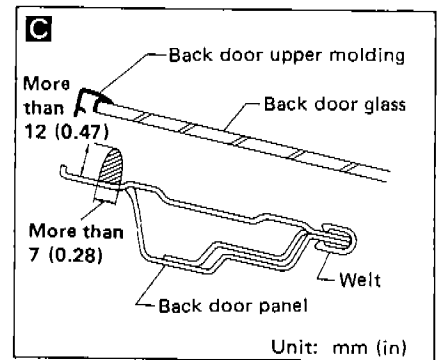
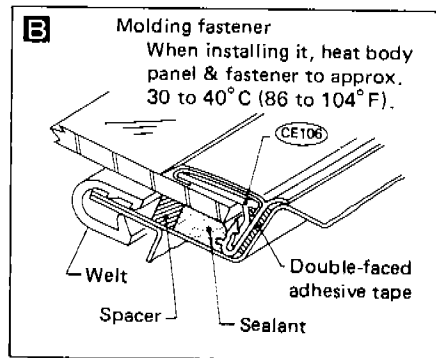
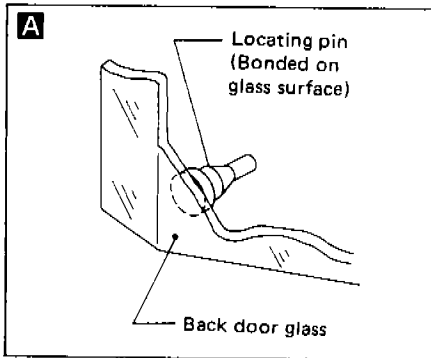
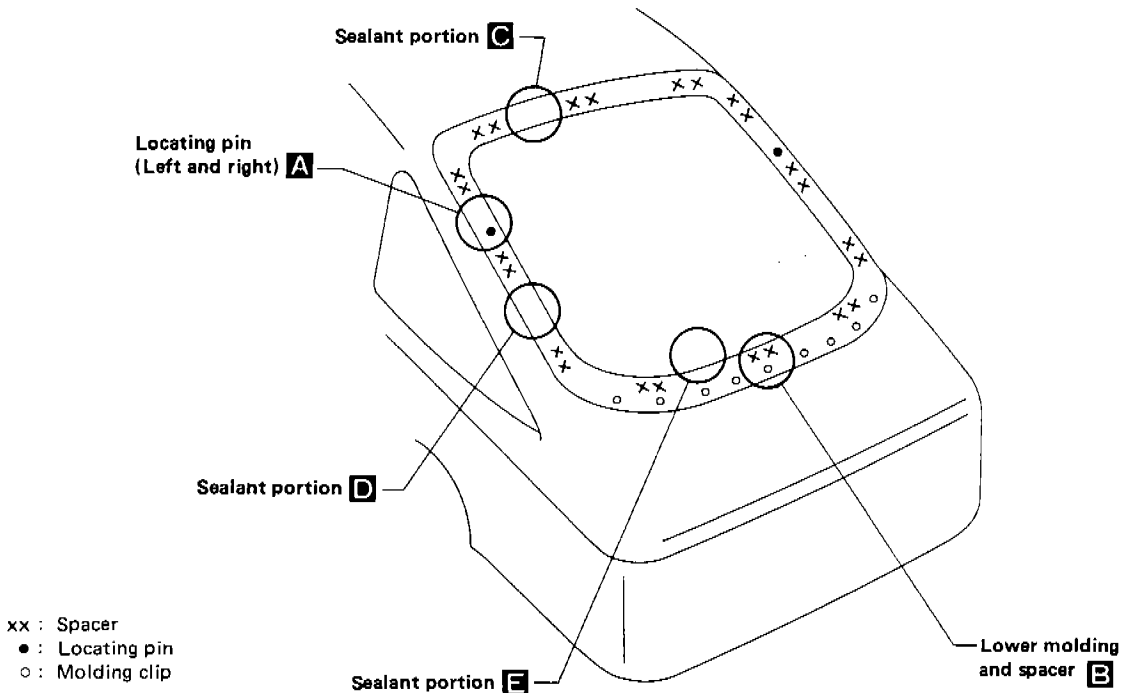

SBF201E

WINDSHIELD AND WINDOWS

Side Window

Side window is a molded type. During removal or installation, observe the following instructions.

1. Cut sealant in the same manner as that outlined under "Windshield."
2. Be careful not to scratch molding when cutting sealant. If molding is scratched, repair.
3. Remove clips and locating pins which have been exposed from vehicle body.

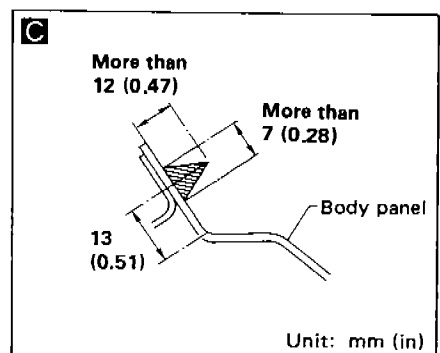
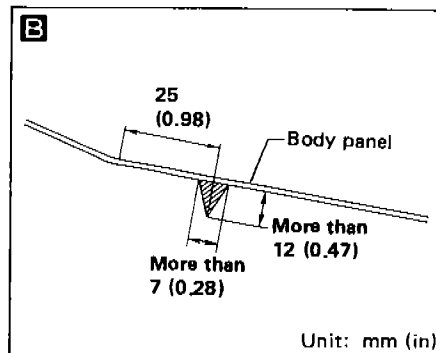
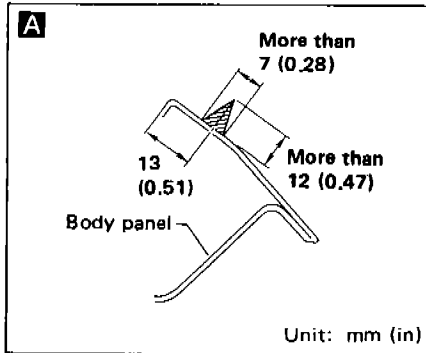
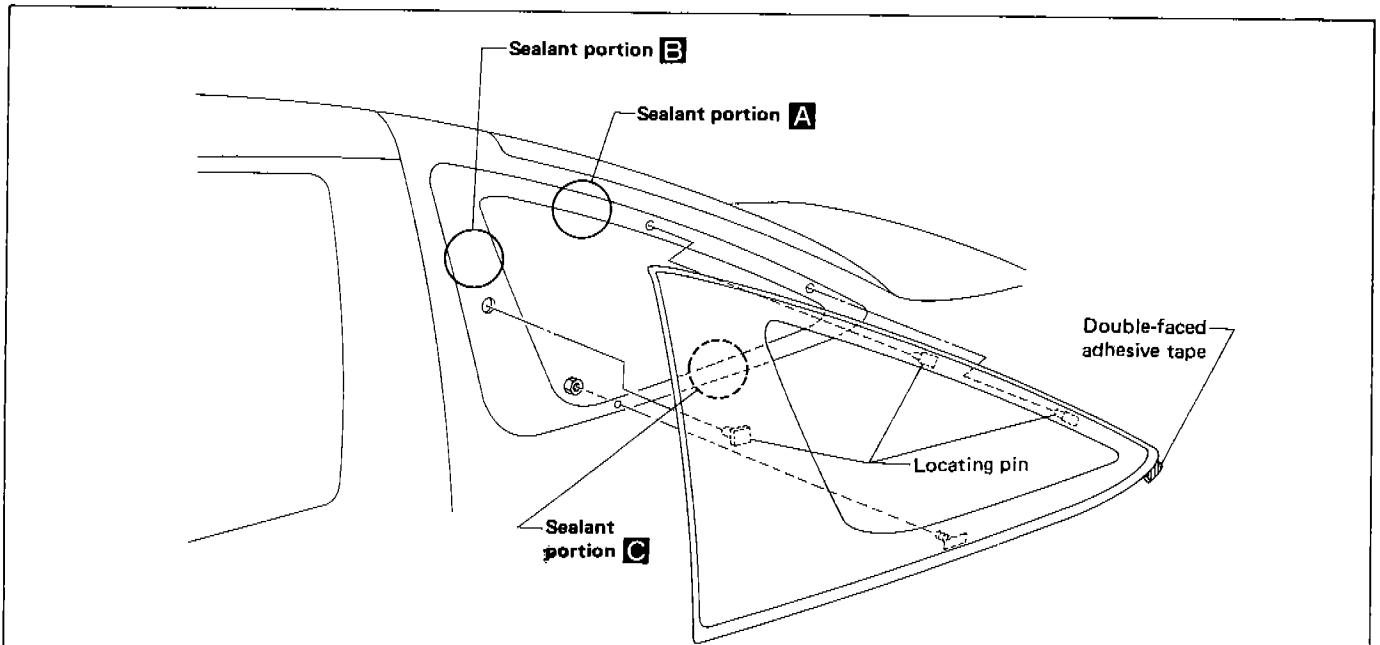
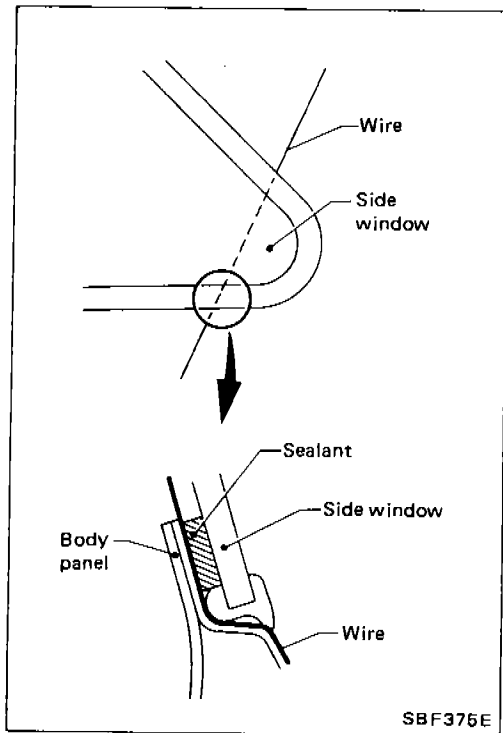

SBF203E

WINDSHIELD AND WINDOWS

Drying Time for Sealant

Reference: Time required for sealant to dry to desired hardness.

Unit: days

| Relative humidity % | 90 | 50 | 25 |
|---------------------|-----|------|------|
| Temperature °C (°F) | | | |
| 40 (104) | 1.5 | 2.5 | 5.0 |
| 25 (77) | 2.5 | 4.0 | 7.5 |
| 5 (41) | 5.0 | 13.0 | 20.5 |

CAUTION:

Advise the user of the fact that vehicle should not be driven on rough roads or surfaces until sealant has properly vulcanized.

Repairing Water Leaks for Windshield and Back Door Window

Leaks can be repaired without removing and reinstalling glass.

If water is leaking between caulking material and body or between glass and caulking material, determine the extent of the leak by applying water while pushing glass outward.

To stop the leak, apply primer and then sealant to the leak point.

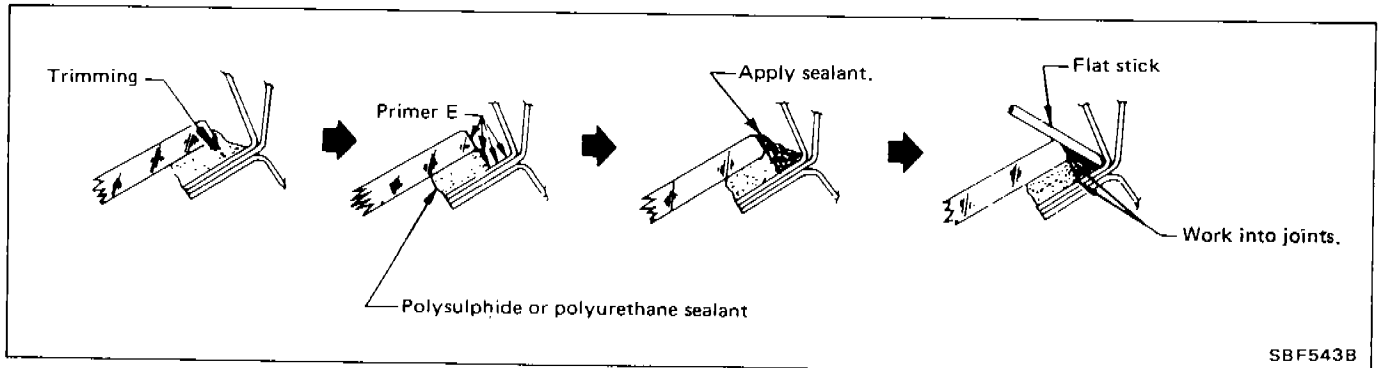

Afterwards, install molding securely.

MIRROR

Door Mirror

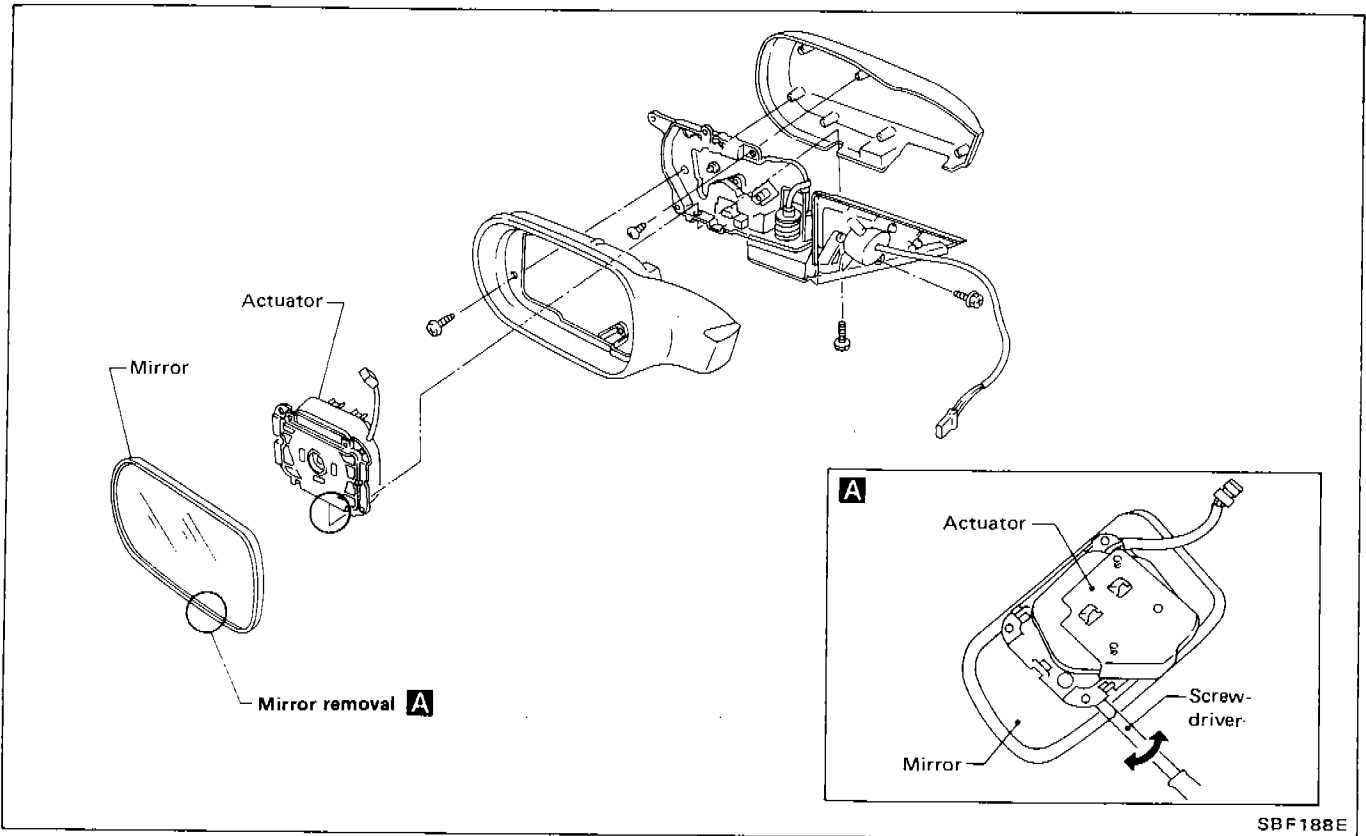

WIRING DIAGRAM

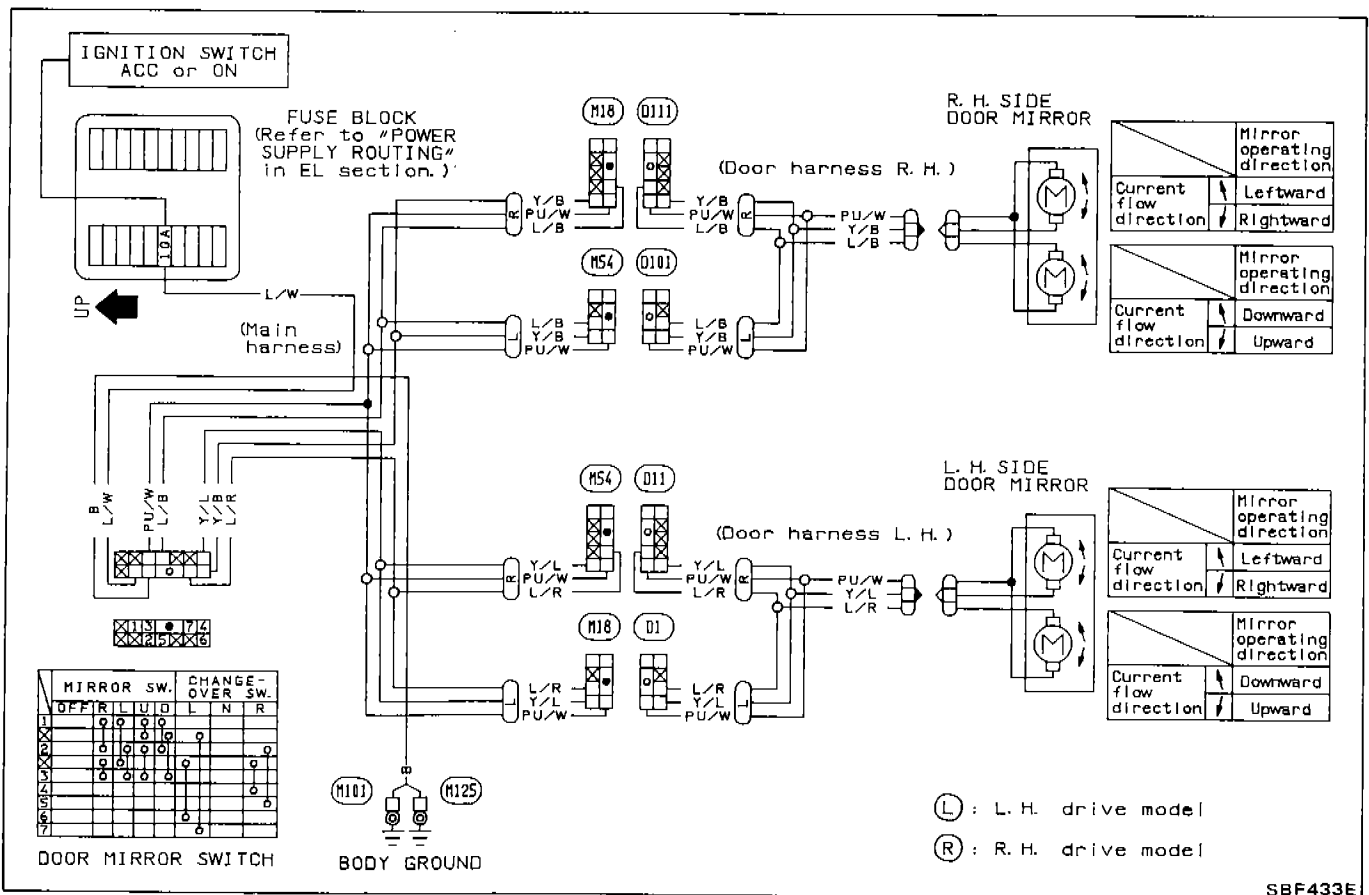

REAR COMBINATION LAMP

- Rear combination lamps are installed with nuts and butyl sealant.

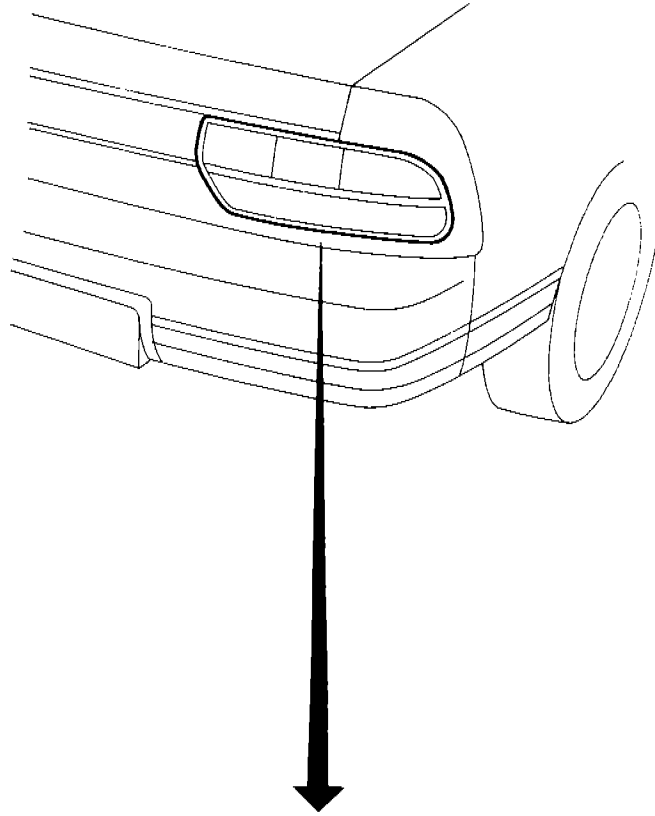

Removal

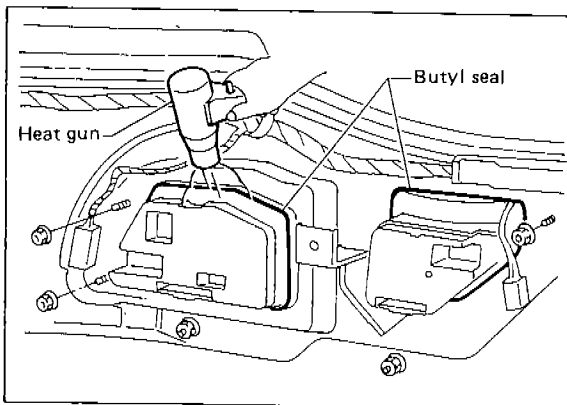

- Warm up lamp assembly area to a temperature of a little below 60°C (140°F).

Installation

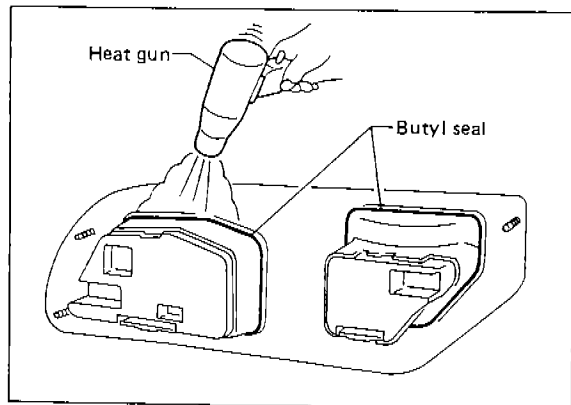

- Apply butyl seal evenly as it tends to become thin in the corners.
- Warm up lamp assembly area to a temperature of a little below 60°C (140°F).

SBF189E

FRONT AND REAR AIR SPOILER

- When installing, make sure that there are not gaps or waves at ends of air spoiler.
- Before installing spoiler, clean and remove oil from surface where spoiler will be mounted.

FRONT AIR SPOILER

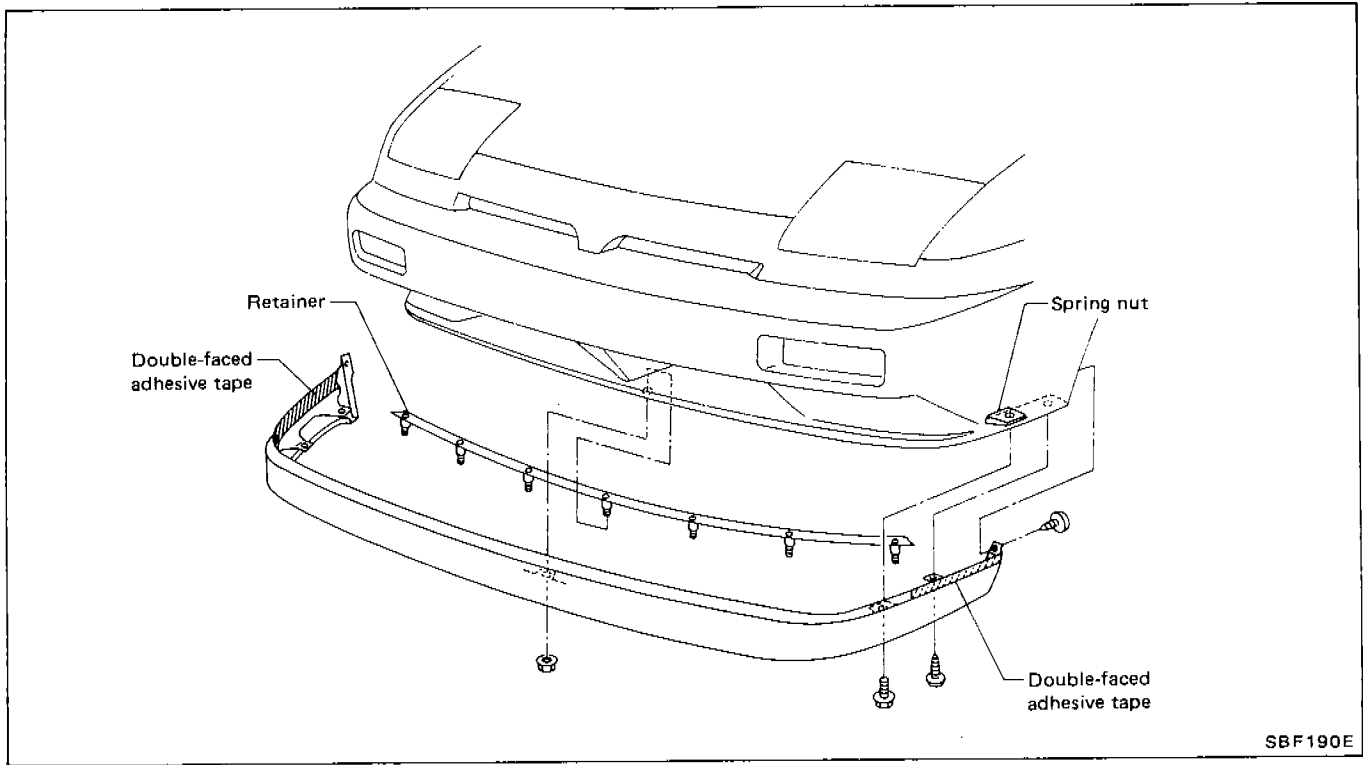

REAR AIR SPOILER

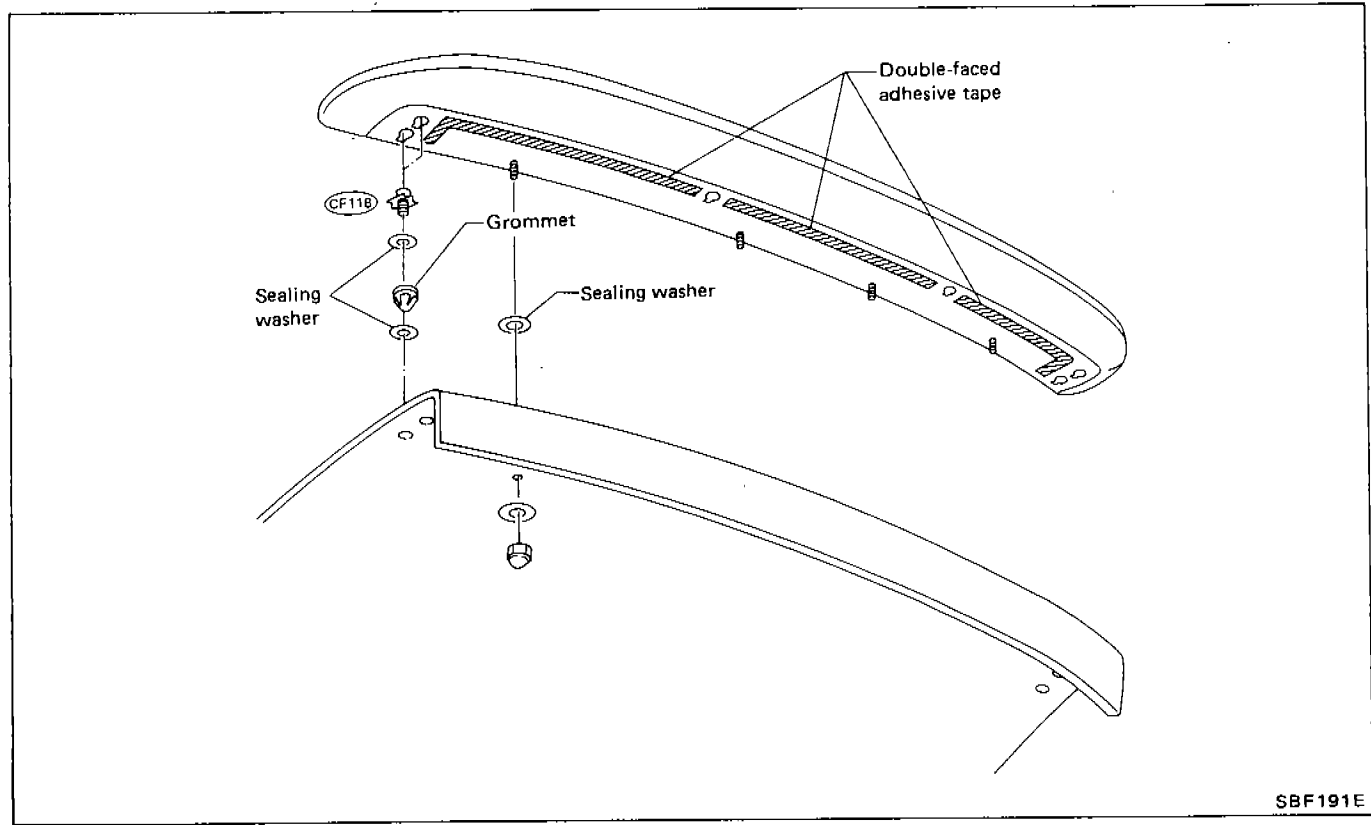

BODY ALIGNMENT

- All dimensions indicated in figures are actual ones.
- When a tram tracking gauge is used, adjust both pointers to equal length and check the pointers and gauge itself to make sure there is no free play.
- When a measuring tape is used, check to be sure there is no elongation, twisting or bending.
- Measurements should be taken at the center of the mounting holes.
- An asterisk (*) following the value at the measuring point indicates that the measuring point on the other side is symmetrically the same value.
- The coordinates of the measurement points are the distances measured from the standard line of "X", "Y" and "Z".

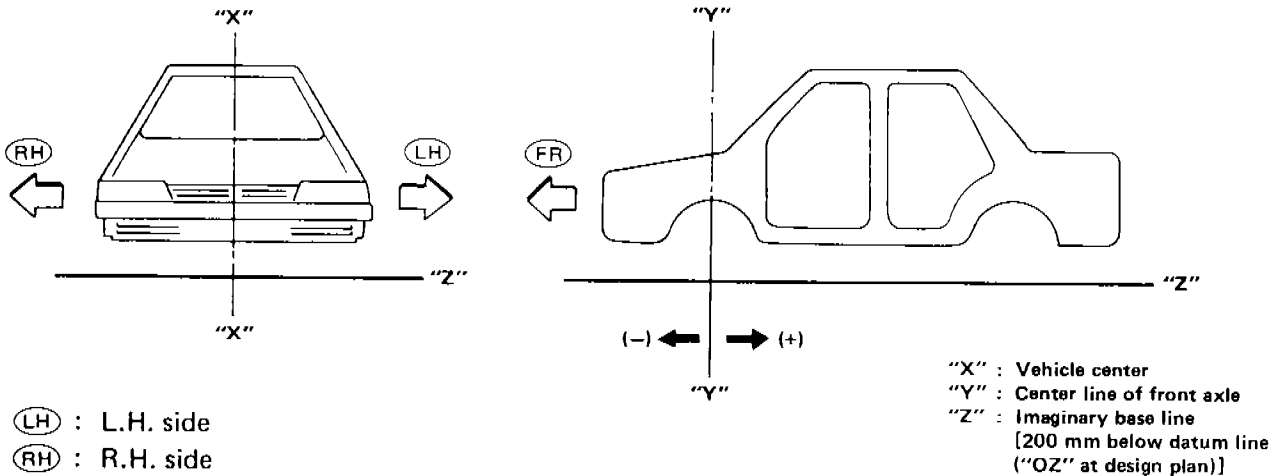

Engine Compartment

MEASUREMENT

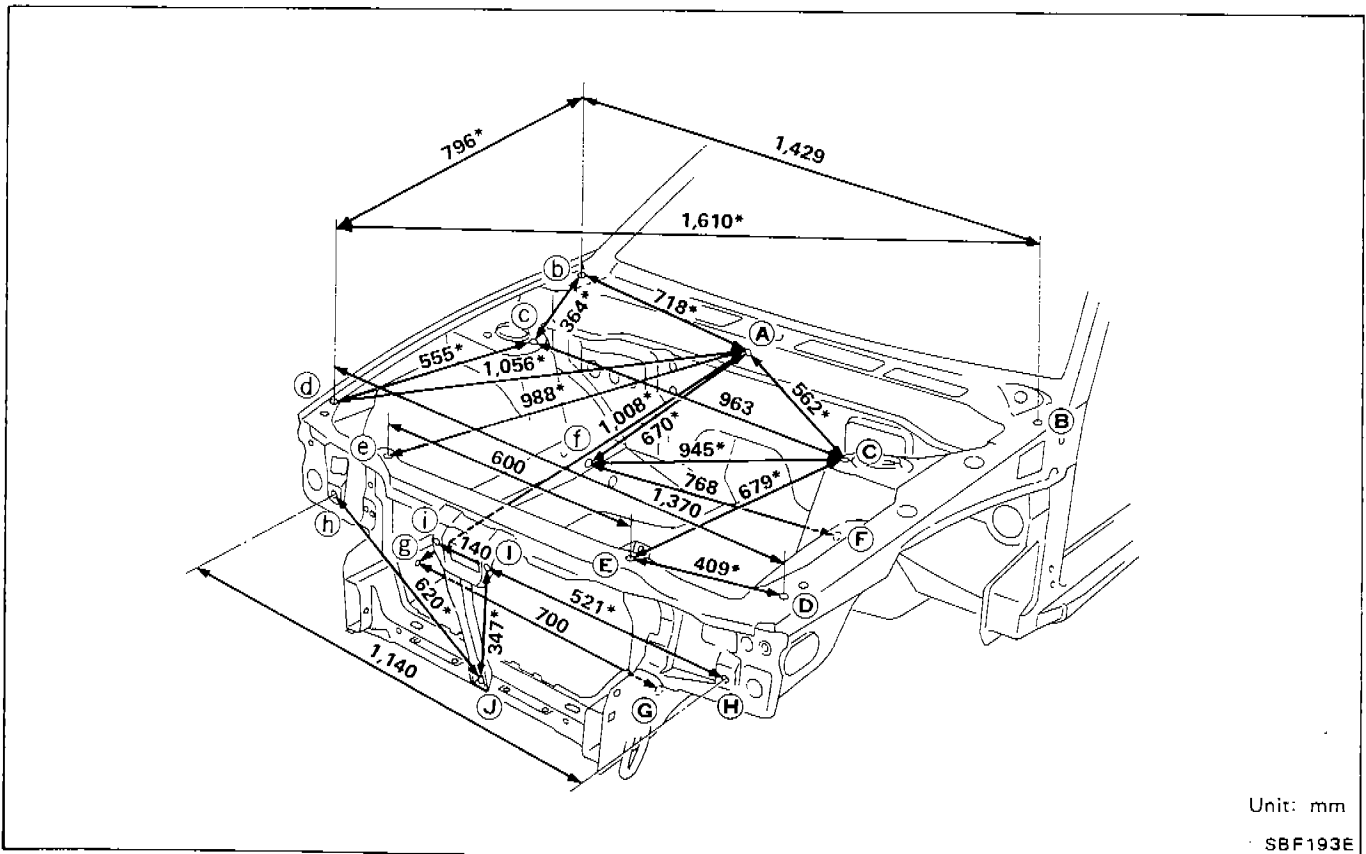

BODY ALIGNMENT

Engine Compartment (Cont'd)

MEASUREMENT POINTS

Unit: mm

Cowl top

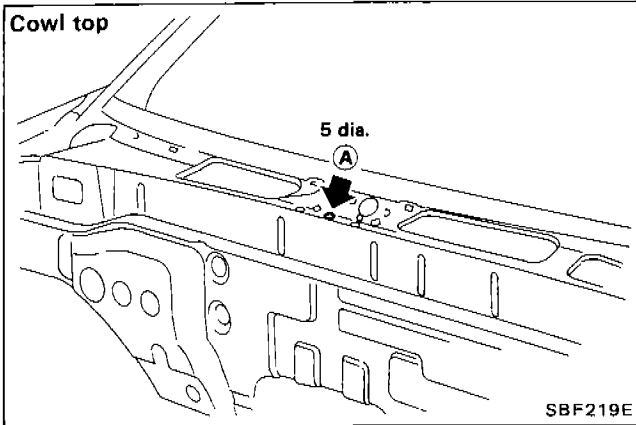

Front side member

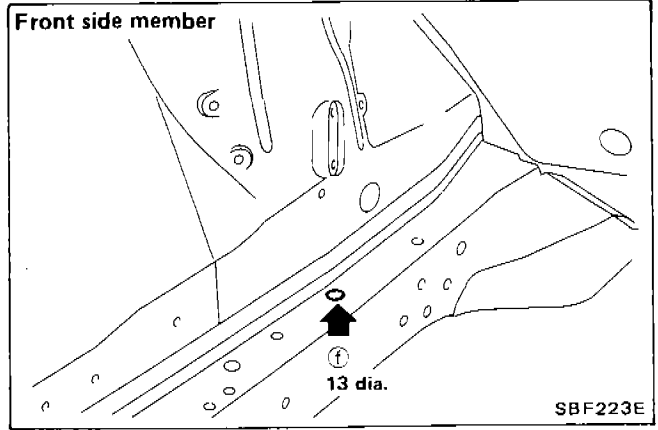

Cowl top side

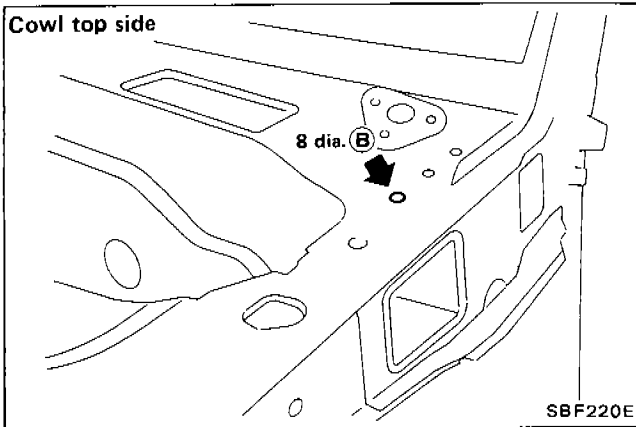

Front side member

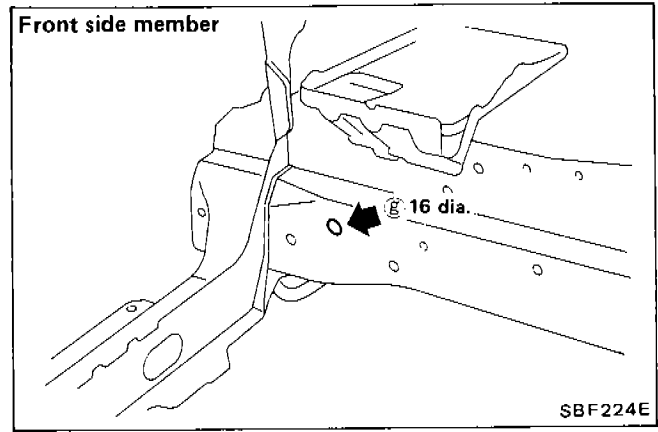

Strut tower

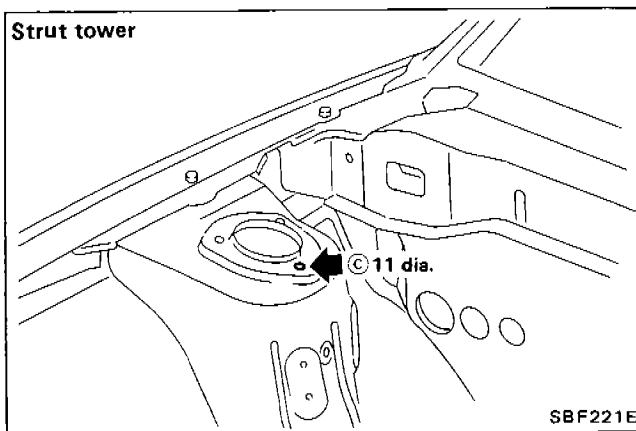

Radiator core center

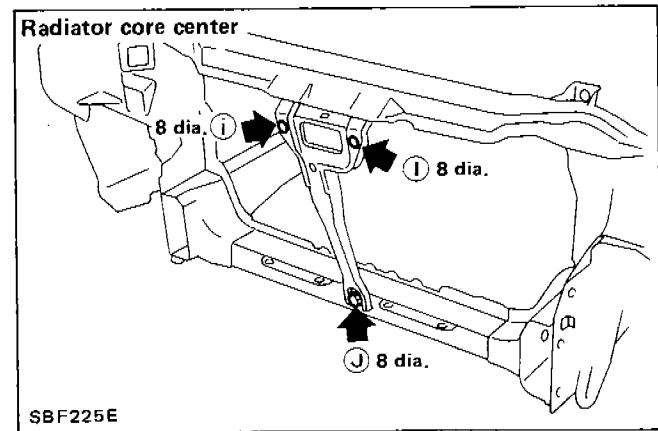

Radiator core side

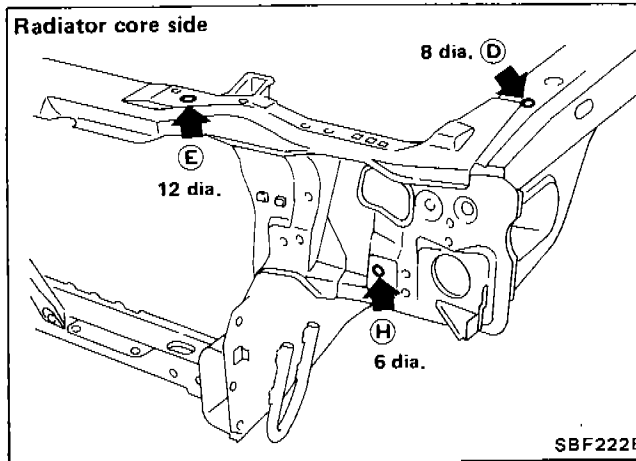

BODY ALIGNMENT

Underbody

MEASUREMENT

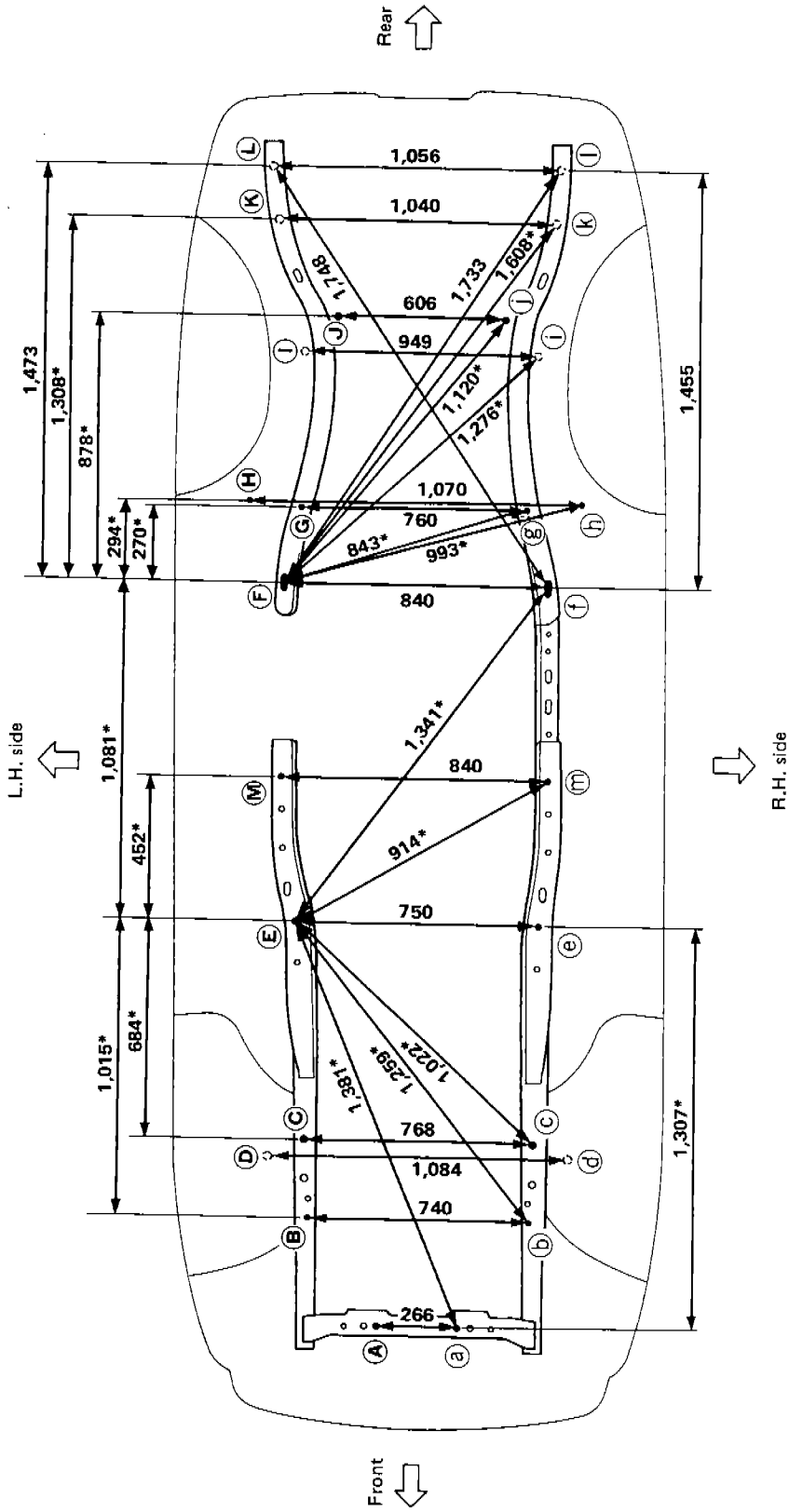

Unit: mm

All dimensions indicated in these figures are actual ones. (There are no projected dimensions.)

BF-38

SBF389EA

BODY ALIGNMENT

Underbody (Cont'd)

MEASUREMENT POINTS

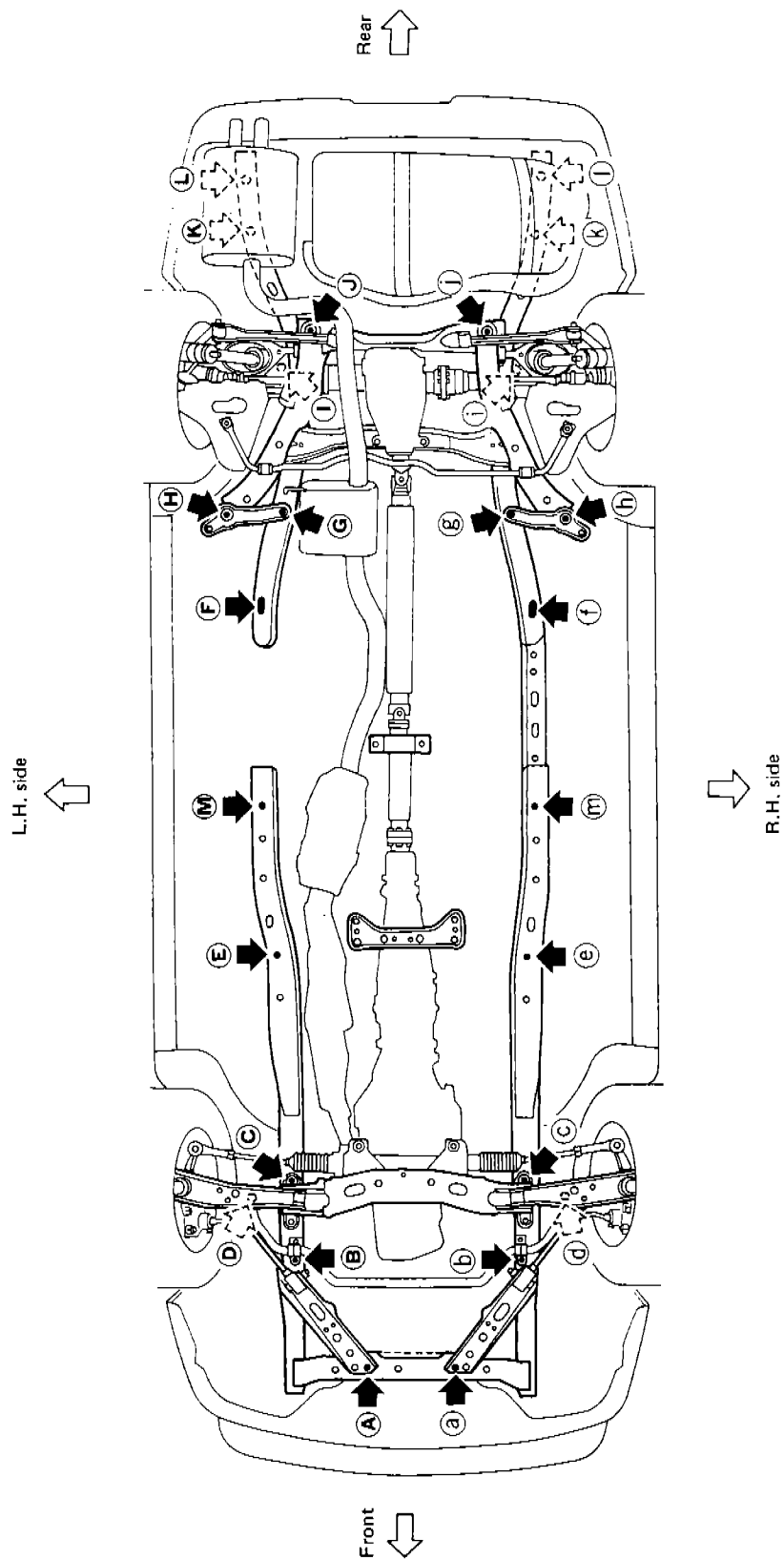

SEF390E

BF-39

BODY ALIGNMENT

Underbody (Cont'd)

Unit: mm

Front and rear strut tower centers

Coordinates:

Ⓓ, ⓓ
X: 542.2
Y: 63.5
Z: 725.7
Ⓡ, Ⓡ
X: 474.5
Y: 2,500
Z: 658.9

Front: Ⓓ, ⓓ 87 dia.
Rear: Ⓡ, Ⓡ 48 dia.

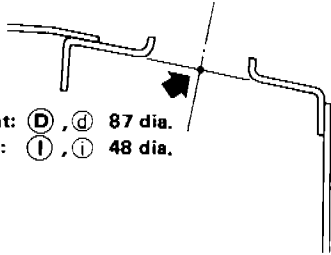

SBF119C

Rear suspension member front mounting bolt threaded end

Coordinates:

ⓗ, ⓗ
X: 535
Y: 2,050
Z: 116.3

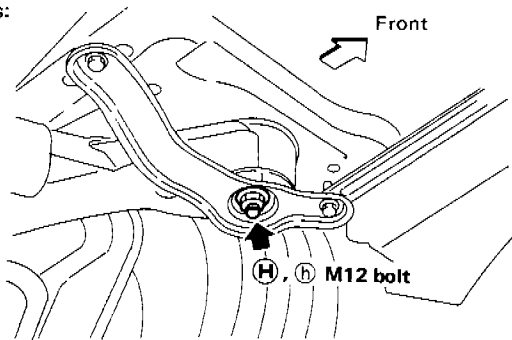

SBF226E

Rear suspension member rear mounting bolt threaded end

Coordinates:

Ⓝ, Ⓝ
X: 303
Y: 2,635
Z: 265.8

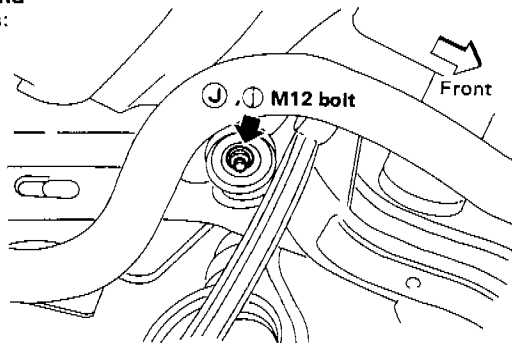

SBF227EA

Front side member and front extension

Coordinates:

Ⓐ, Ⓐ
X: 132.9
Y: -582
Z: 189
Ⓑ, Ⓑ
X: 370
Y: -304
Z: 255
Ⓒ, Ⓒ
X: 384.2
Y: 32
Z: 255
Ⓔ, Ⓔ
X: 375
Y: 700
Z: 106.2
Ⓜ, Ⓜ
X: 420
Y: 1,150
Z: 106.2

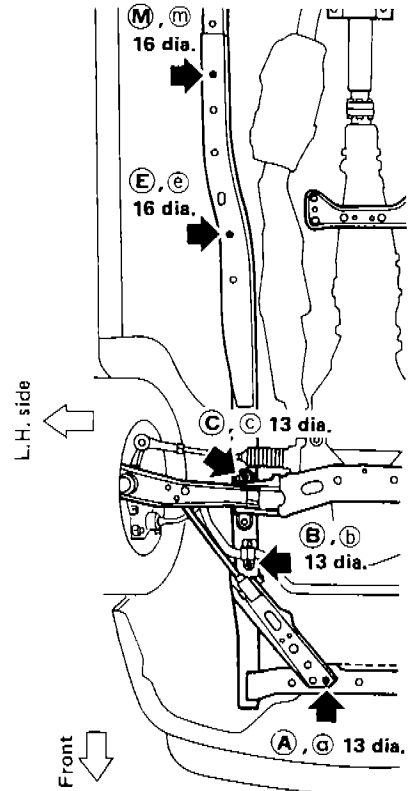

SBF271E

Center side member, rear side member and rear extension

Coordinates:

Ⓕ, Ⓕ
X: 420
Y: 1,780
Z: 101.5
Ⓖ, Ⓖ
X: 380
Y: 2,030
Z: 195.8
Ⓚ, Ⓚ
X: 520
Y: 3,050
Z: 398.8
Ⓛ, Ⓛ
X: 528
Y: 3,221
Z: 386
Ⓡ, Ⓡ
X: 528
Y: 3,200
Z: 400

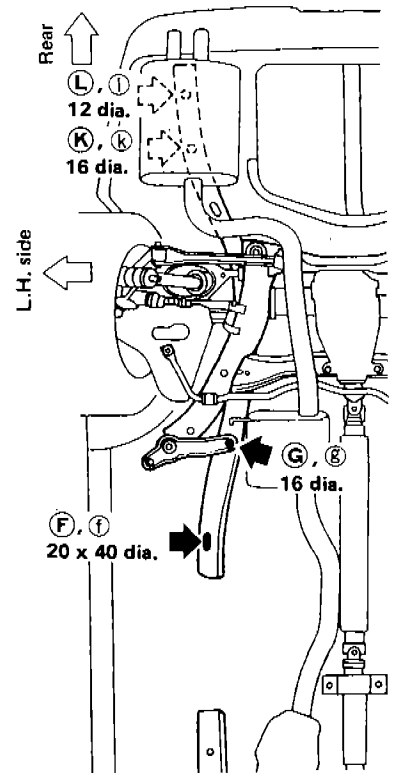

SBF391E

HEATER & AIR CONDITIONER

SECTION **HA**

CONTENTS

| | |
|-------------------------------------------------------|-------|
| AIR FLOW AND COMPONENT LAYOUT | HA- 2 |
| DOOR CONTROL | HA- 6 |
| DESCRIPTION — Push Control | HA- 8 |
| PUSH CONTROL UNIT | HA-12 |
| HEATER ELECTRICAL CIRCUIT | HA-15 |
| PRECAUTIONS | HA-17 |
| PRECAUTIONS FOR REFRIGERANT CONNECTION | HA-18 |
| PREPARATION | HA-19 |
| DISCHARGING, EVACUATING, CHARGING AND CHECKING | HA-21 |
| DESCRIPTION OF AIR CONDITIONER | HA-28 |
| SERVICE PROCEDURES | HA-30 |
| A/C PERFORMANCE TEST | HA-33 |
| COMPRESSOR OIL — For NVR 140S (ATSUGI make) | HA-39 |
| COMPRESSOR OIL — For DKV-14C (DIESEL-KIKI make) | HA-41 |
| COMPRESSOR — Precautions | HA-43 |
| COMPRESSOR — Model NVR 140S (ATSUGI make) | HA-44 |
| COMPRESSOR — Model DKV-14C (DIESEL-KIKI make) | HA-47 |
| A/C COMPONENT LAYOUT | HA-50 |
| A/C ELECTRICAL CIRCUIT | HA-52 |
| TROUBLE DIAGNOSES | HA-56 |
| SERVICE DATA AND SPECIFICATIONS (S.D.S.) | HA-86 |

HA

When you read wiring diagrams:

- Read GI section, "HOW TO READ WIRING DIAGRAMS".
- See EL section, "POWER SUPPLY ROUTING" for power distribution circuit.

When you perform trouble diagnoses, read GI section, "HOW TO FOLLOW FLOW CHART IN TROUBLE DIAGNOSES".

AIR FLOW AND COMPONENT LAYOUT

Air Flow

EXCEPT EUROPE MODEL

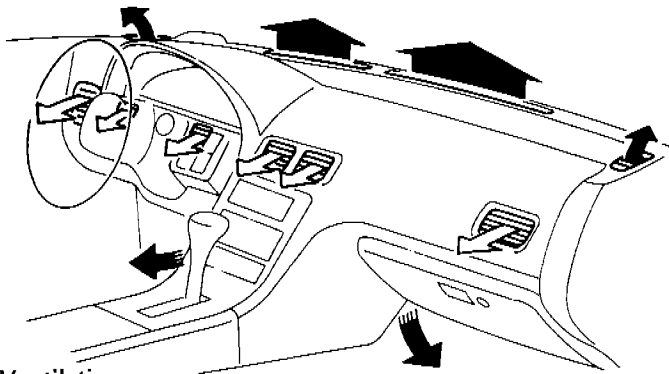

Ventilation

Air conditioner switch
REC Mode switches
switch

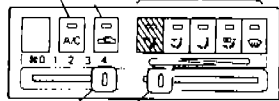

Temperature control lever
Fan lever

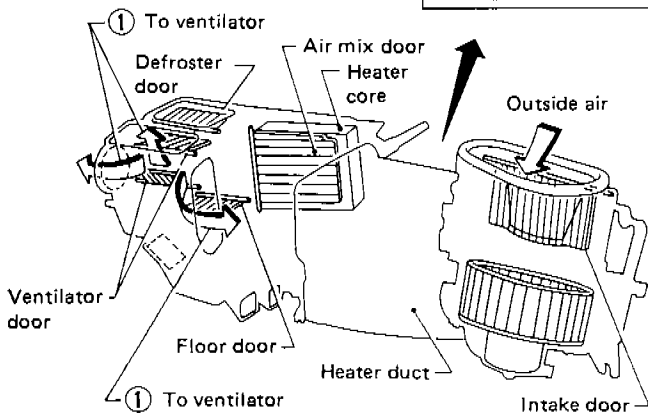
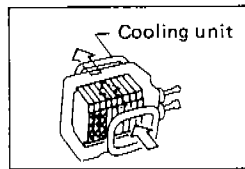

Bi-level

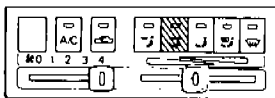

1 To ventilator

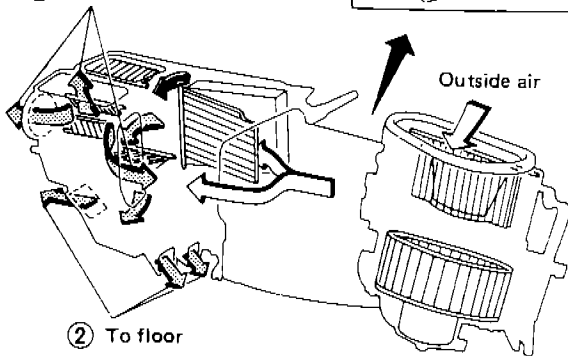
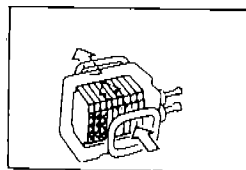

Floor

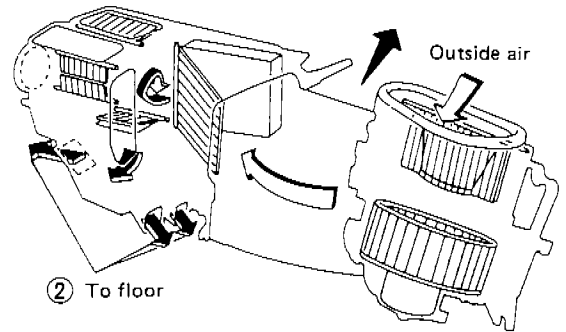
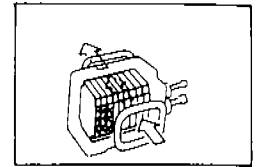
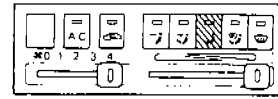

Floor and defroster

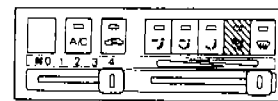

3 To defroster

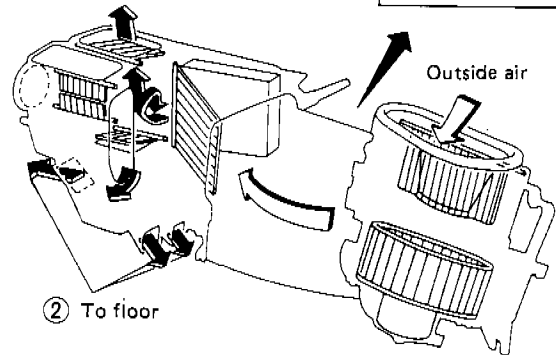
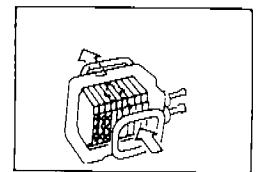

Defroster

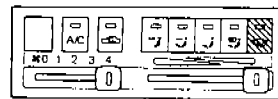

3 To defroster

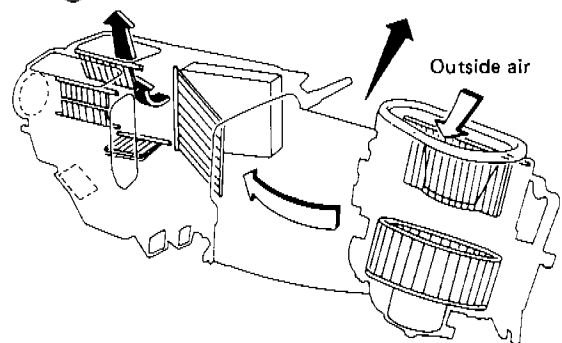
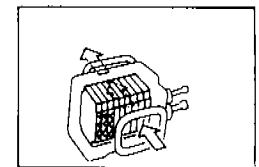

➡ : Air passed through heater core

↔ : Mixed air (➡ + ←)

↔ : Air not passed through heater core

This illustration is for L.H. drive models.
For R.H. drive models, it is basically same.

RHA625A

AIR FLOW AND COMPONENT LAYOUT

Air Flow (Cont'd)

EUROPE MODEL

Floor

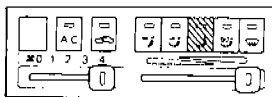

③ To defroster

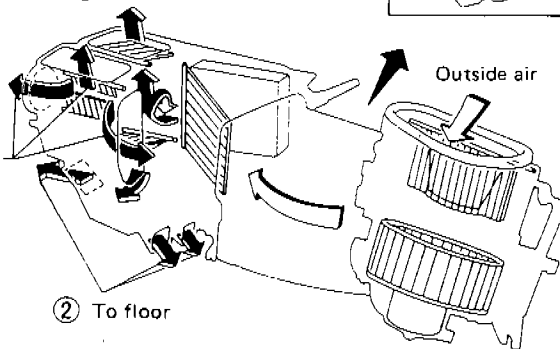
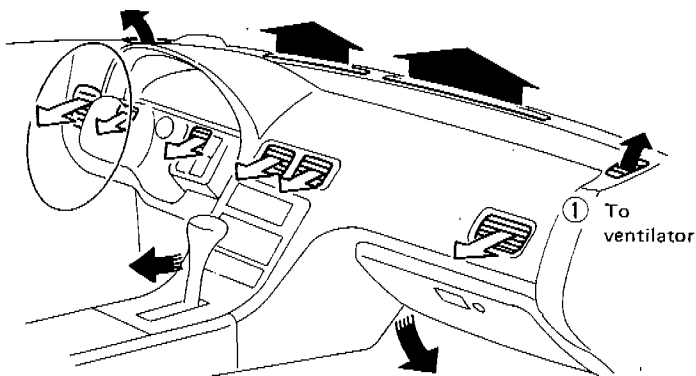
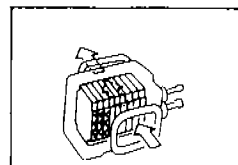

② To floor

Ventilation

Air conditioner switch
REC switch Mode switches

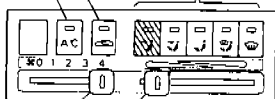

Temperature control lever
Fan lever

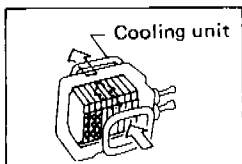

Floor and defroster

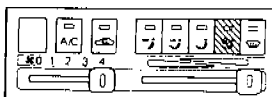

③ To defroster

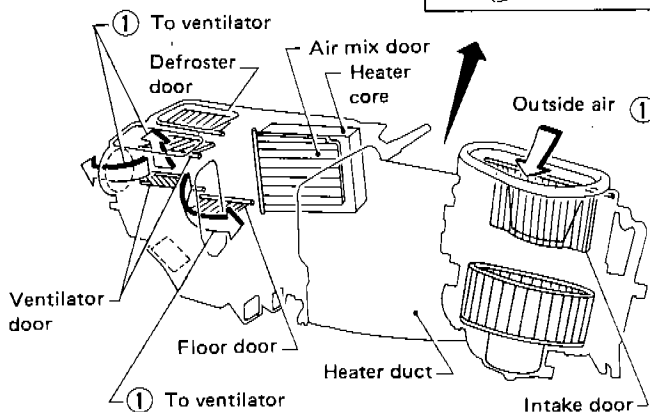
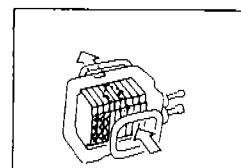

① To ventilator

Defroster door
Air mix door
Heater core

Outside air

① To ventilator

Ventilator door

Floor door

Heater duct

① To ventilator

Intake door

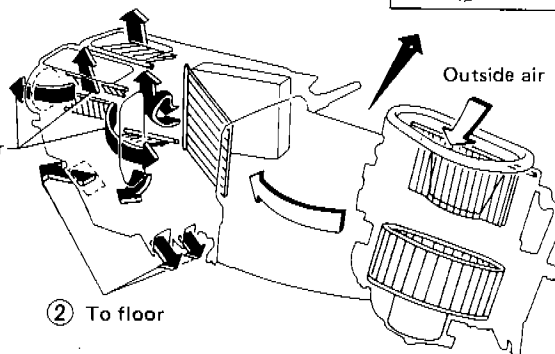

② To floor

Defroster



③ To defroster

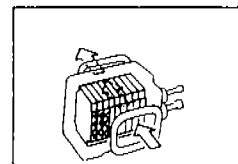

Bi-level



① To ventilator

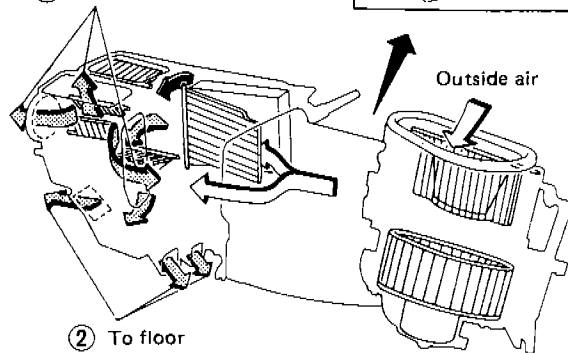
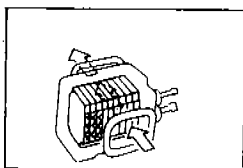

② To floor

Outside air

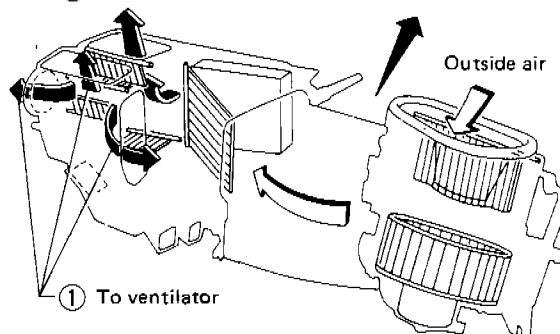

① To ventilator

Outside air

➡ : Air passed through heater core

➡➡ : Mixed air (➡ + ➡)

➡ : Air not passed through heater core

This illustration is for L.H. drive models.
For R.H. drive models, it is basically same.

RHA626A

AIR FLOW AND COMPONENT LAYOUT

Air Flow (Cont'd)

AIR DISTRIBUTION RATIOS

Except Europe model

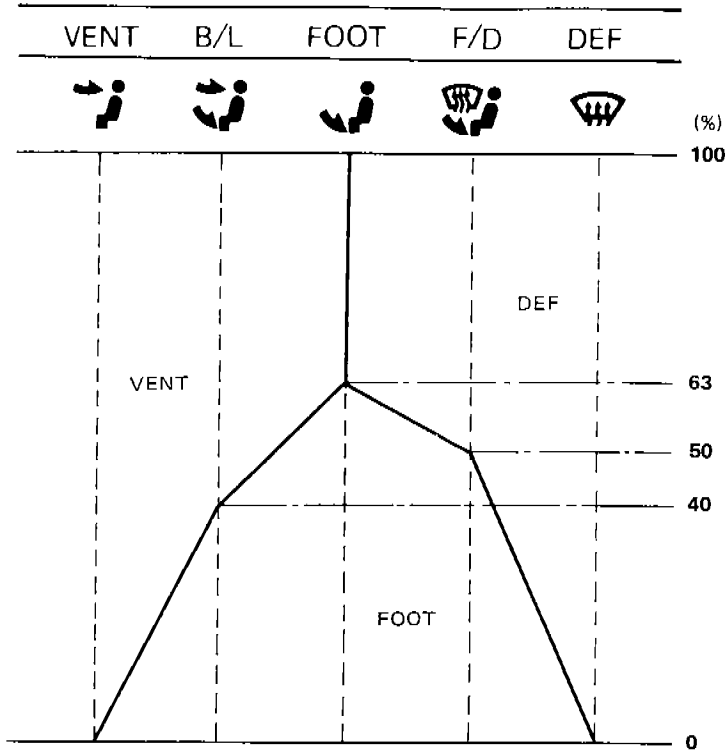

Europe model

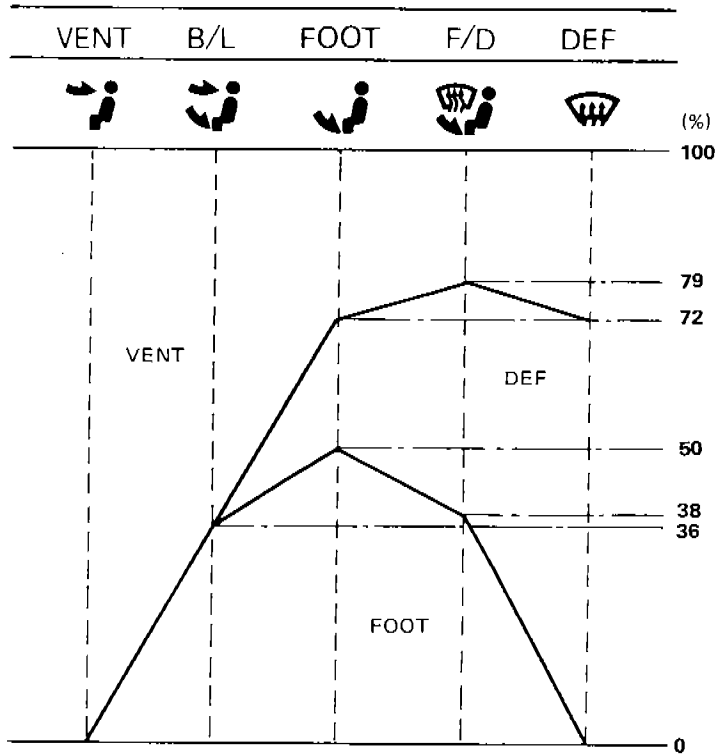

RHA627A

AIR FLOW AND COMPONENT LAYOUT

Component Layout

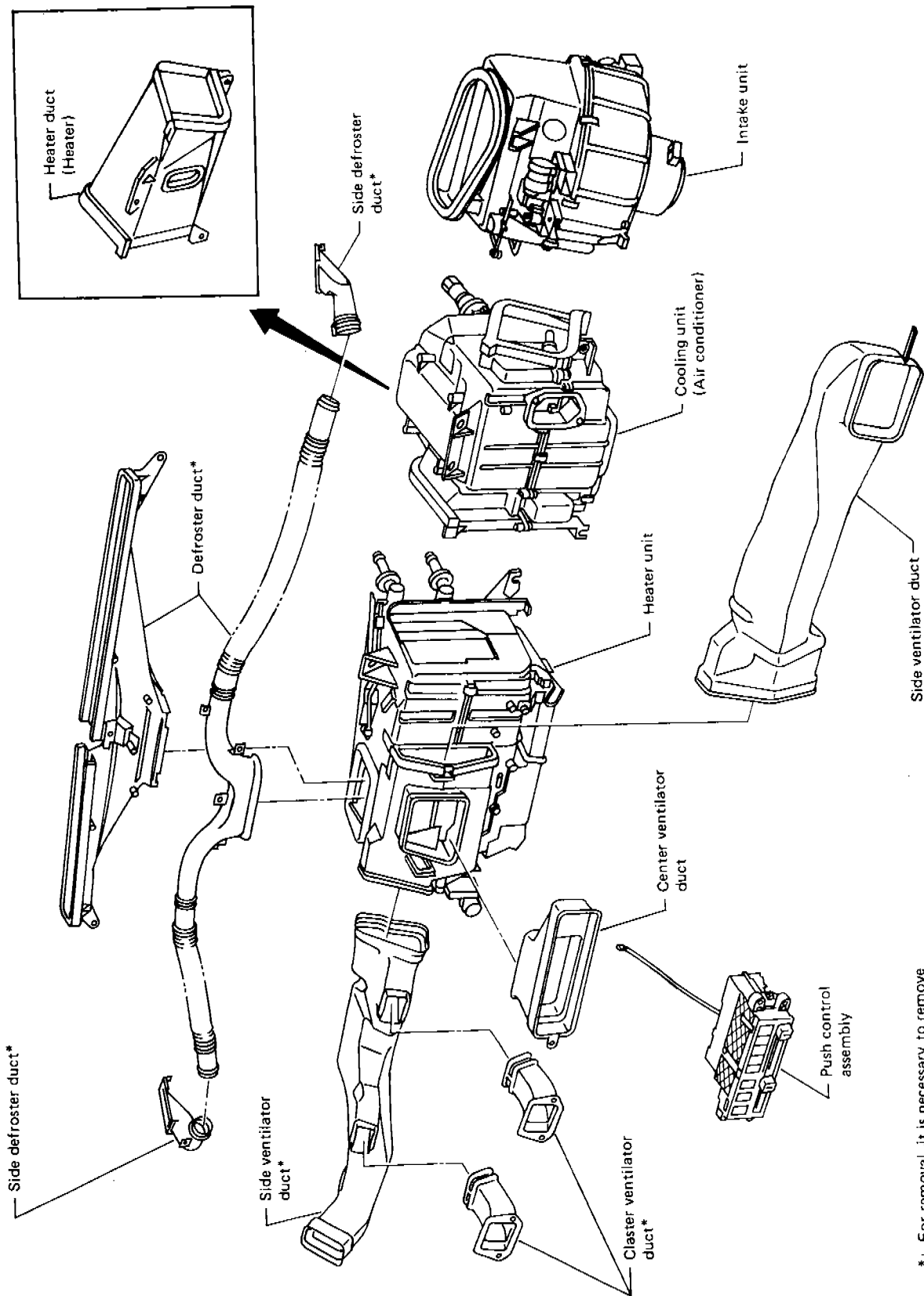

*: For removal, it is necessary to remove instrument assembly.

This illustration is for L.H. drive models. For R.H. drive models, it is basically same.

RHA373A

DOOR CONTROL

Control Cable Adjustment

- When disconnecting the control cable, remove the E-ring and take off the cable while pushing the cable outer.
- The following illustrations are for L.H. drive models. For R.H. drive models, it is basically same.

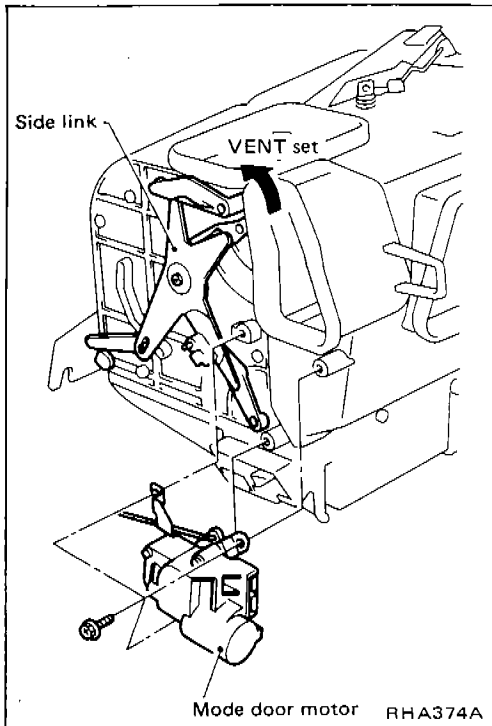

MODE DOOR

1. Move side link with hand and hold mode door in VENT mode.
2. Install mode door motor on heater unit and connect it to body harness.
3. Turn ignition switch to ACC.
4. Turn VENT switch ON.
5. Attach mode door motor rod to side link rod holder.
6. Turn DEF switch ON. Check that side link operates at the fully-open position. Also turn VENT switch ON to check that side link operates at the fully-open position.

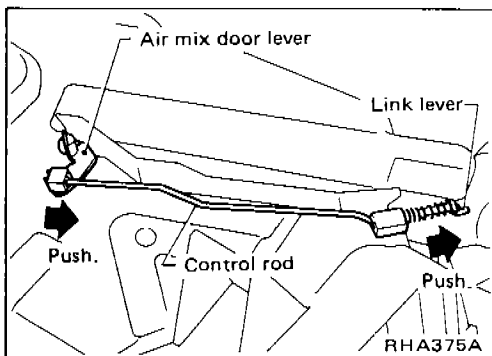

WATER COCK CONTROL ROD

- When adjusting water cock control rod, first disconnect temperature control cable from air mix door lever. Reconnect and readjust temperature control cable.

1. Push air mix door lever in direction of arrow.
2. Pull control rod of water cock in direction of arrow so as to make clearance of about 2 mm (0.08 in) between ends of rod and link lever and connect the rod to door lever.

After connecting control rod, check it operates properly.

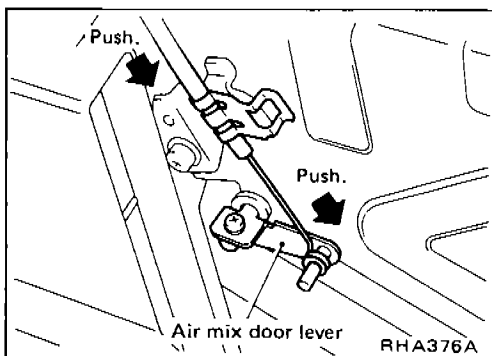

TEMPERATURE CONTROL CABLE

- Clamp the cable while pushing cable outer and air mix door lever in direction of arrow.

After positioning control cable, check it operates properly.

DOOR CONTROL

Control Cable Adjustment (Cont'd)

INTAKE DOOR

1. Connect intake door motor harness connector before installing to intake door motor.
2. Turn ignition switch to ACC.
3. Turn REC switch ON.
4. Install intake door motor on intake unit.
5. Install intake door lever.
6. Set intake door lever in REC and secure door rod to holder.
7. Check that intake door operates properly when REC switch is turned ON and OFF.

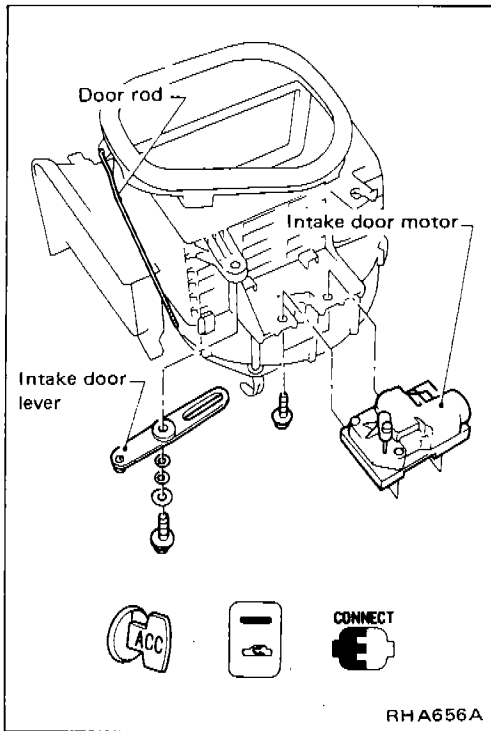

DESCRIPTION — Push Control

Push Control System

L.H.D. MODEL

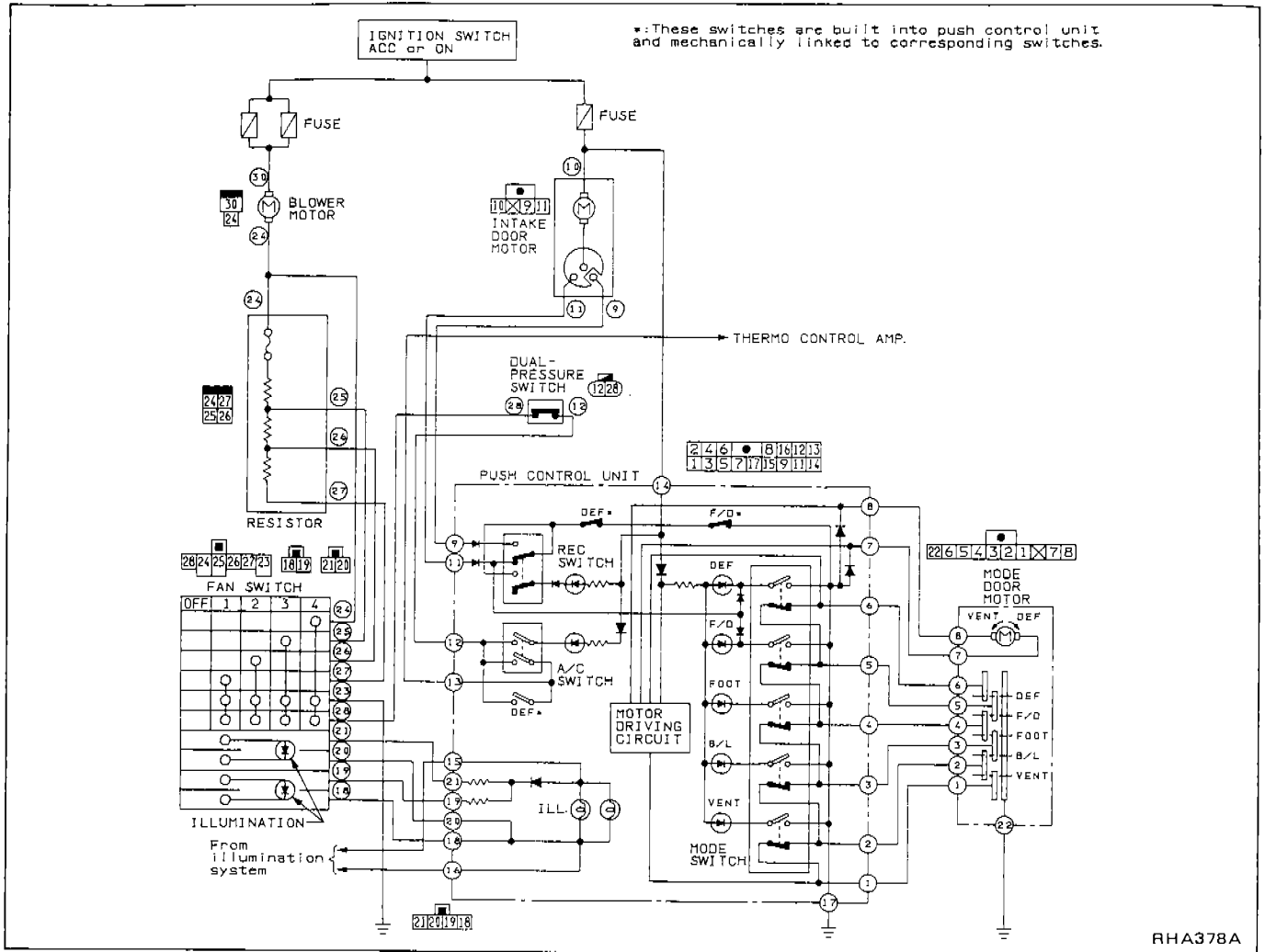

This push control system operates the intake and mode door motors to activate their corresponding doors.

Switches and their control functions

| Switch | Indicator illuminates | | | | | | | Air outlet | Intake air | Compressor |
|--------|-----------------------|---|---|---|--|---|-----|------------------------------------------------------|------------|------------|
| | A/C | | | | | | | | | |
| A/C | ○ | | | | | | | | | ON*1 |
| Mode | | ○ | | | | | | Refer to "AIR DISTRIBUTION RATIOS". (See page HA-4.) | | |
| | | | ○ | | | | | | FRE | |
| | | | | ○ | | | | | FRE | ON*1 |
| | | | | | | ○ | | | | |
| | | | | | | | ○*2 | REC*2 | | |

*1: Compressor is operated by thermo control amp.

*2: Depending on mode switch position.

DESCRIPTION — Push Control

Push Control System (Cont'd)

R.H.D. MODEL

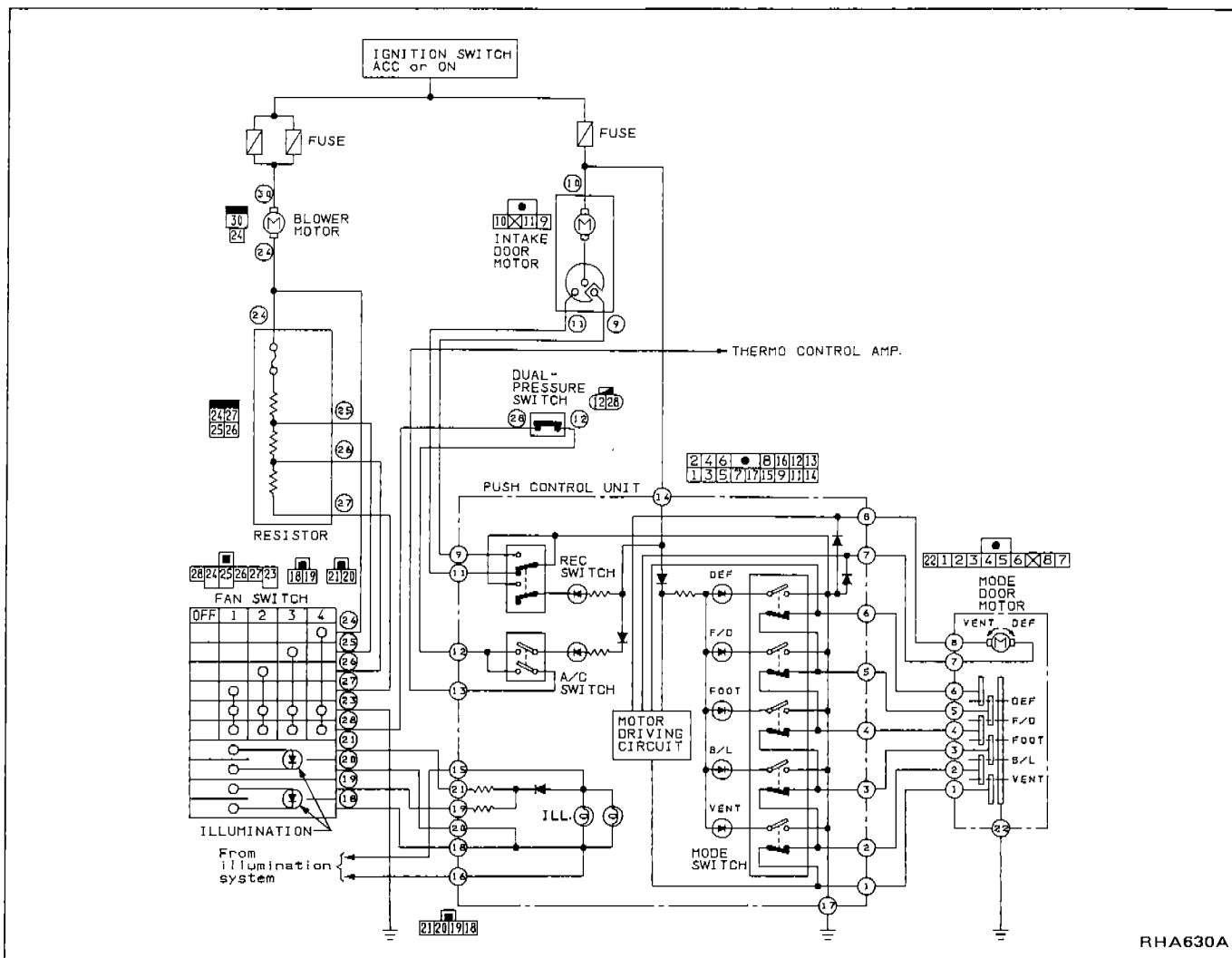

RHA630A

This push control system operates the intake and mode door motors to activate their corresponding doors.

Switches and their control functions

| Switch | Indicator illuminates | | | | | | | Air outlet | Intake air | Compressor |
|--------|-----------------------|---|---|---|---|--|--|------------------------------------------------------|------------|------------|
| | A/C | | | | | | | | | |
| A/C | ○ | | | | | | | | | ON* |
| Mode | | ○ | | | | | | Refer to "AIR DISTRIBUTION RATIOS". (See page HA-4.) | | |
| | | | ○ | | | | | | | |
| | | | | ○ | | | | | | |
| | | | | | ○ | | | | | |
| | | | | | ○ | | | | | |
| | | | | | | | | | REC | |

*: Compressor is operated by thermo control amp.

Intake Door Motor

The intake door motor is installed on the front portion of the intake unit. Using a rod and link it opens and closes the intake door.

When the REC switch is ON (OFF), the ground line of the intake door motor is switched from terminal ⑪ to ⑨ (⑨ to ⑪). This causes the motor to start because the position switch contacts built into it are set to the current flow position. The contacts turn along with the motor. When they reach the non-current flow position, the motor will stop. The motor always turns in the same direction.

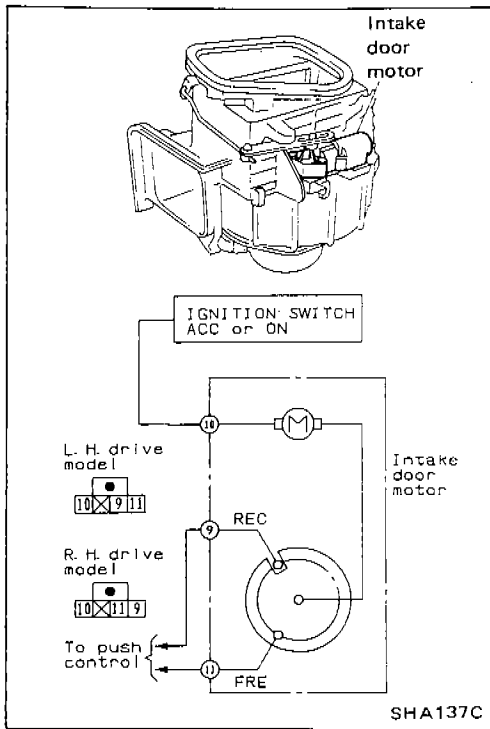

Mode Door Motor

L.H.D. MODEL

The mode door motor is located on the left side of the heater unit. Through the side link it opens and closes the vent, foot and defroster door.

When one mode switch is pushed, the position switch built into it reads the corresponding mode to determine the direction of the motor rotation. As soon as the desired mode is set, the position switch stops the motor.

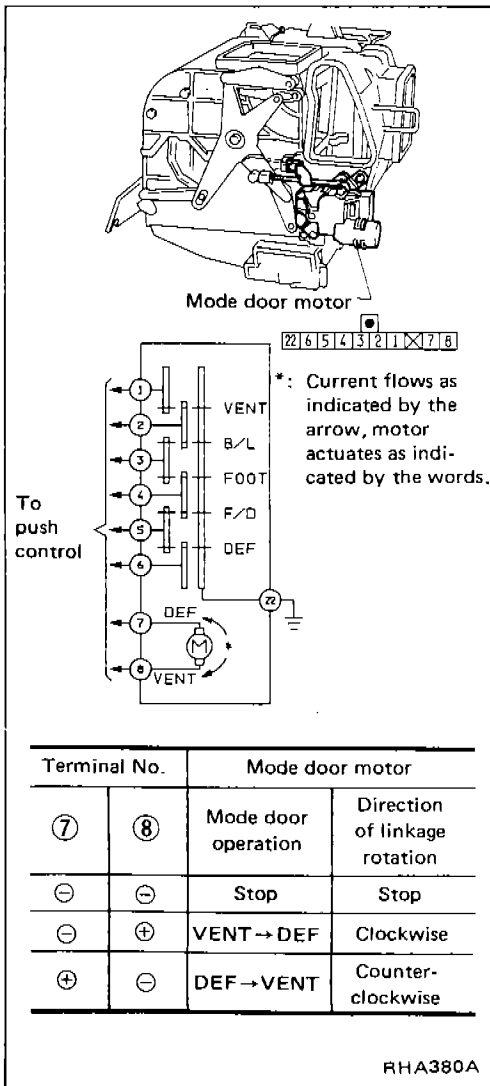

| Terminal No. | | Mode door motor | |
|--------------|---|---------------------|-------------------------------|
| ⑦ | ⑧ | Mode door operation | Direction of linkage rotation |
| ⊖ | ⊖ | Stop | Stop |
| ⊖ | ⊕ | VENT → DEF | Clockwise |
| ⊕ | ⊖ | DEF → VENT | Counter-clockwise |

DESCRIPTION — Push Control

Mode Door Motor (Cont'd)

R.H.D. MODEL

The mode door motor is located on the right side of the heater unit. Through the side link it opens and closes the vent, foot and defroster door.

When one mode switch is pushed, the position switch built into it reads the corresponding mode to determine the direction of the motor rotation. As soon as the desired mode is set, the position switch stops the motor.

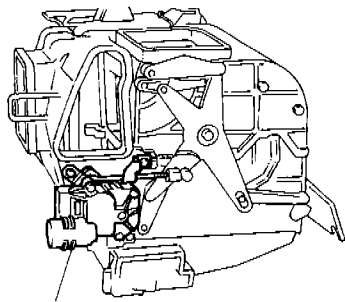

Mode door motor

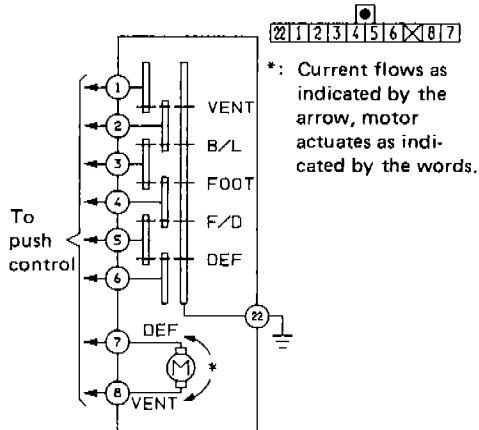

| Terminal No. | | Mode door motor | |
|--------------|---|---------------------|-------------------------------|
| ⑦ | ⑧ | Mode door operation | Direction of linkage rotation |
| ⊖ | ⊖ | Stop | Stop |
| ⊖ | ⊕ | VENT → DEF | Counter-clockwise |
| ⊕ | ⊖ | DEF → VENT | Clockwise |

RHA631A

PUSH CONTROL UNIT

Removal and Installation

1. Remove cluster lid C.
2. Remove audio (radio).
3. Remove four screws of push control unit.
4. Remove temperature control cable.
5. Disconnect push control unit harness connectors.
6. Remove push control unit.
7. Installation is in the reverse order of removal.

Refer to **Control Cable Adjustment** for temperature control cable.

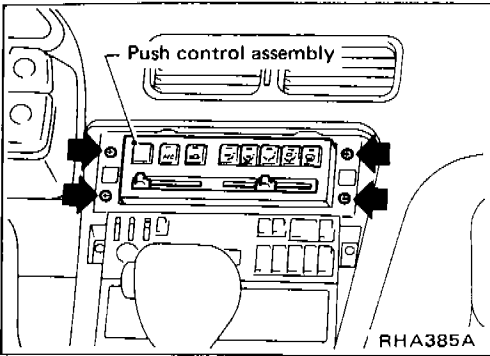
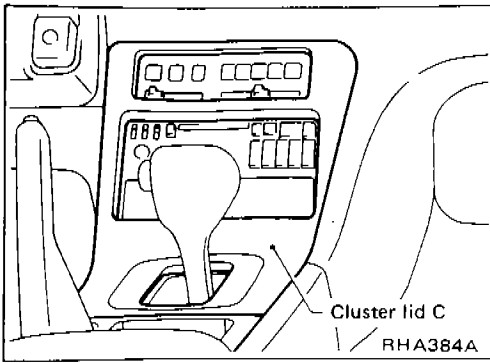

Overhaul — Push control unit assembly

This illustration is for L.H. drive models.
For R.H. drive models, it is basically same.

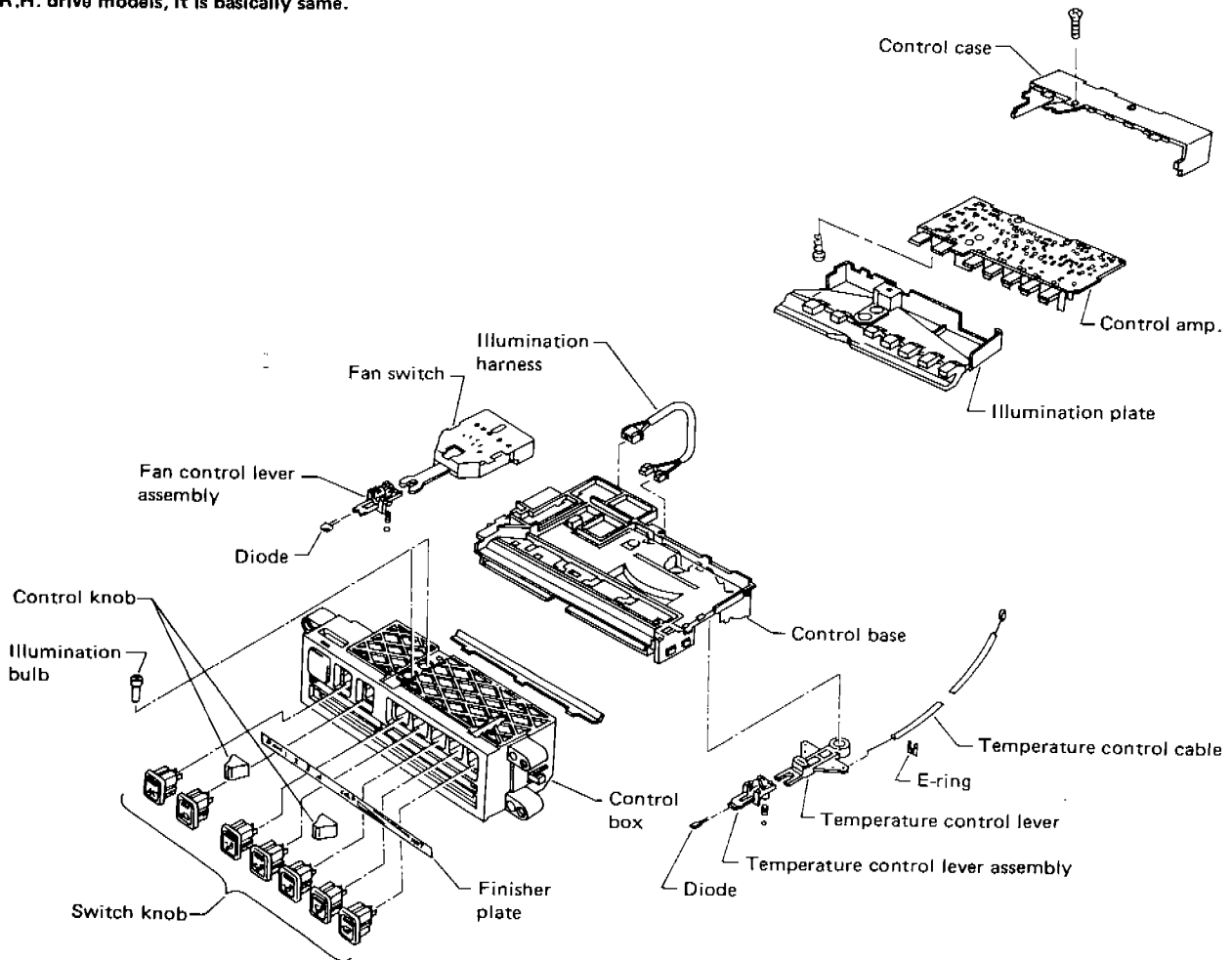

RHA386A

PUSH CONTROL UNIT

Overhaul — Push control unit assembly (Cont'd)

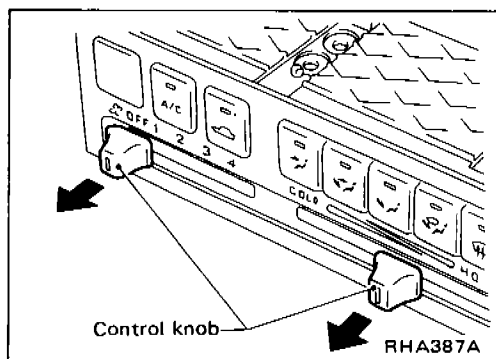

1. Remove two knobs.

Wrap knobs with a cloth and pull in direction indicated by arrow as shown in figure at left. Be careful not to scratch knobs during removal.

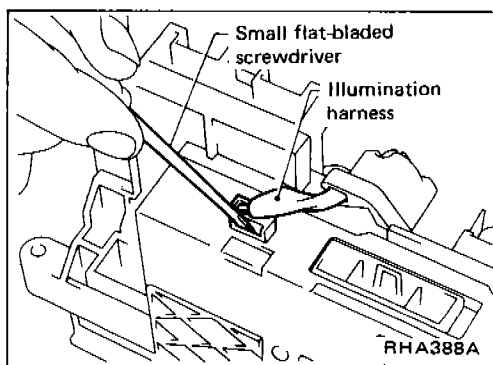

2. Disconnect illumination harness connectors.

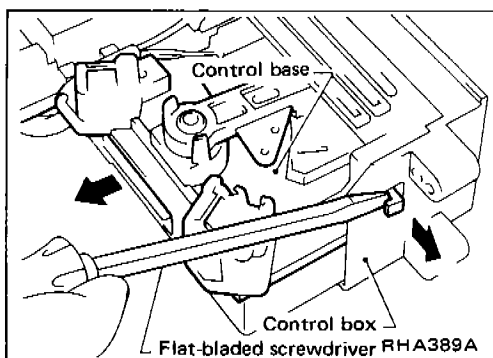

3. Remove control base.

Undo hook at each end of control box and remove control base from control box by moving it in direction indicated by arrow.

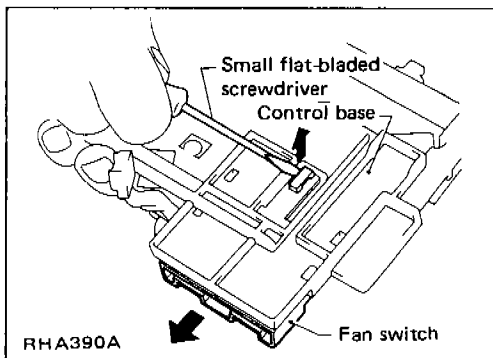

4. Remove fan switch.

5. Remove control knobs.

Wrap finisher with a cloth and remove knobs using pliers or similar tool. Be careful not to scratch finisher's surface.

PUSH CONTROL UNIT

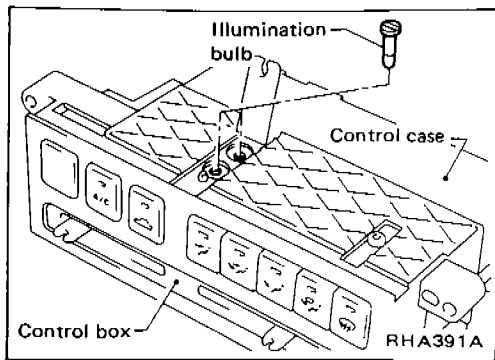

Overhaul — Push control unit assembly (Cont'd)

6. Remove illumination bulb.
7. Remove control case.

8. Remove illumination plate.

Be careful not to scratch control amp. when removing illumination plate.

9. Remove finisher plate.
10. Remove control amp.

Be careful not to damage substrate when removing.

11. Disconnect temperature control cable.
12. Installation is in reverse order of removal.

HEATER ELECTRICAL CIRCUIT

Wiring Diagram

L.H.D. MODEL

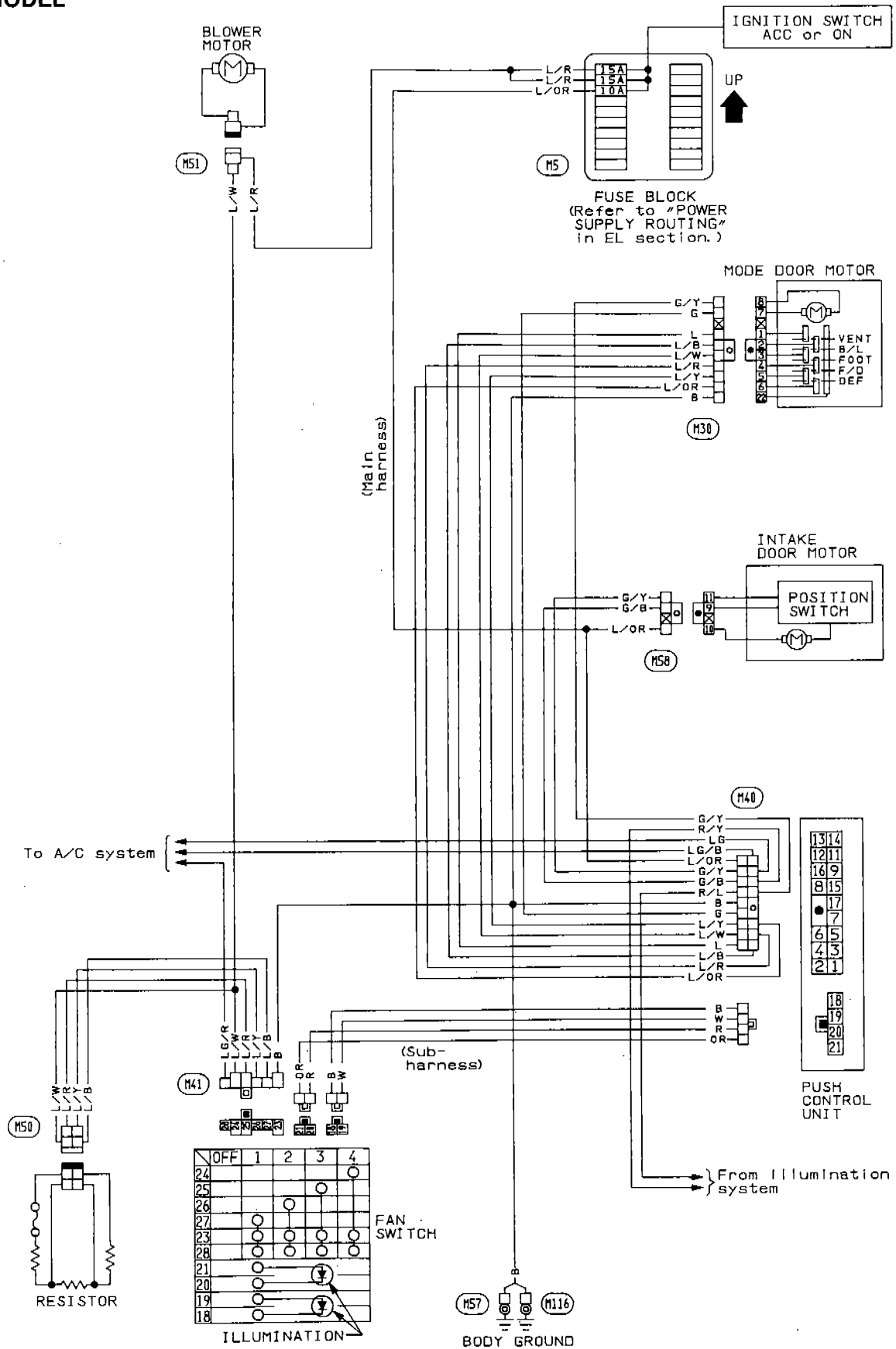

RHA628A

PRECAUTIONS

WARNING:

- Always wear eye protection when working around the system.
- Always be careful that refrigerant does not come in contact with your skin.
- Keep refrigerant containers stored below 40°C (104°F) and never drop from high places.
- Work in well-ventilated area because refrigerant gas evaporates quickly and breathing may become difficult due to the lack of oxygen.
- Keep refrigerant away from open flames because poisonous gas will be produced if it burns.
- Do not increase can temperature beyond 40°C (104°F) in charging.
- Do not heat refrigerant can with an open flame. There is a danger that can will explode.

CAUTION:

- Do not use steam to clean surface of condenser or evaporator. Be sure to use cold water or compressed air.
- Compressed air must never be used to clean a dirty line. Clean with refrigerant gas.

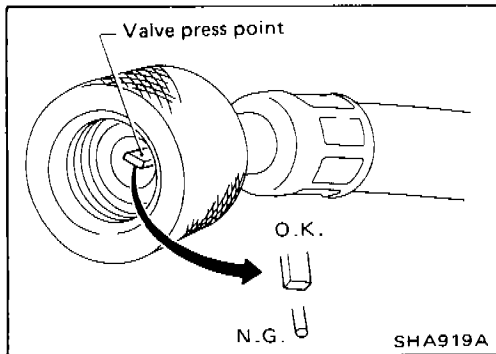

- Do not use manifold gauge whose press point shape is different from that shown. Otherwise, insufficient evacuating may occur.

- Do not over-tighten service valve cap.
- Do not allow refrigerant to rush out. Otherwise, compressor oil will be discharged along with refrigerant.

PRECAUTIONS FOR REFRIGERANT CONNECTION

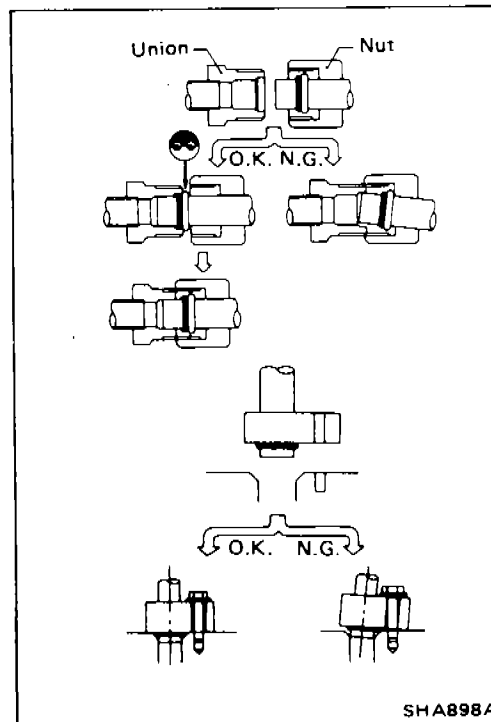
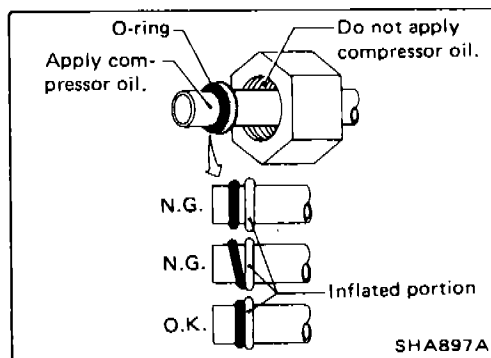
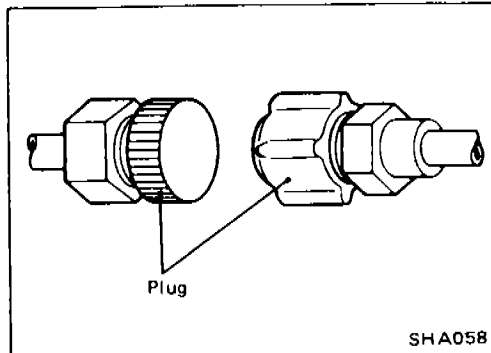
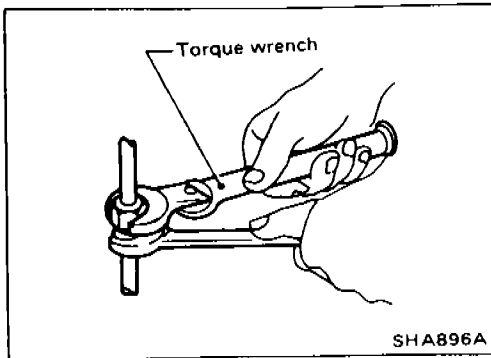

WARNING:

Gradually loosen discharge side hose fitting, and remove it after remaining pressure has been released.

CAUTION:

When replacing or cleaning refrigerant cycle components, observe the following.

- Do not leave compressor on its side or upside down for more than 10 minutes, as compressor oil will enter low pressure chamber.
- When connecting tubes, always use a torque wrench.
- After disconnecting tubes, plug all openings immediately to prevent entrance of dirt and moisture.

- Always replace used O-rings.
- When connecting tube, apply compressor oil to portions shown in illustration. Be careful not to apply oil to threaded portion.
- O-ring must be closely attached to inflated portion of tube.



- After inserting tube into union until O-ring is no longer visible, tighten nut to specified torque.
- After connecting line, conduct leak test and make sure that there is no leakage from connections. When the gas leaking point is found, disconnect that line and replace the O-ring. Then tighten connections of seal seat to the specified torque.

PREPARATION

SPECIAL SERVICE TOOLS

NVR 140S model

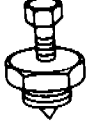
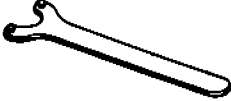
*: Special tool or commercial equivalent

| Tool name Tool number | Description | |
|----------------------------------|-----------------------------------------------------------------------------------|------------------------------------|
| KV998VR001 Clutch hub puller |  | Removing clutch disc |
| KV99231010* Clutch hub wrench |  | Removing shaft nut and clutch disc |
| KV99235160* Nut wrench |  | Removing lock nut |



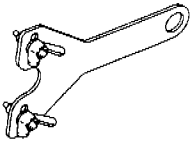
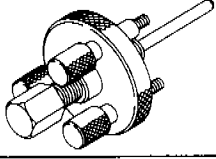
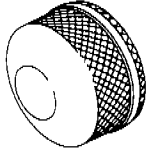

DKV-14C model

*: Special tool or commercial equivalent

| Tool number Tool name | Description | |
|-----------------------------------|-------------------------------------------------------------------------------------|------------------------------------|
| KV99231162* Clutch disc wrench |  | Removing shaft nut and clutch disc |
| KV99232340 Clutch disc puller |  | Removing clutch disc |
| KV99234330 Pulley installer |  | Installing pulley |

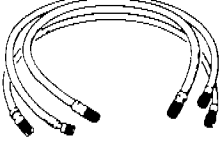
PREPARATION

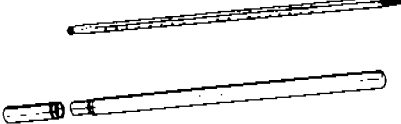
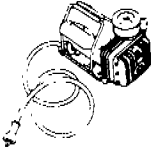
SERVICE TOOLS

| Tool name | Description |
|------------------------|-----------------------------------------------------------------------------------------------------------------------------------------------------------------------------------|
| Manifold gauge |  Discharging and charging refrigerant into system |
| Charging hose |  Discharging, evacuating and charging refrigerant into system |
| Charge valve |  Discharging and charging refrigerant into system |
| Thermometer |  Checking temperature |
| Vacuum pump |  Evacuating refrigerant system |
| Electric leak detector | Nominal sensitivity: 15 - 25 g (0.53 - 0.88 oz)/year  Checking refrigerant leaks |

DISCHARGING, EVACUATING, CHARGING AND CHECKING

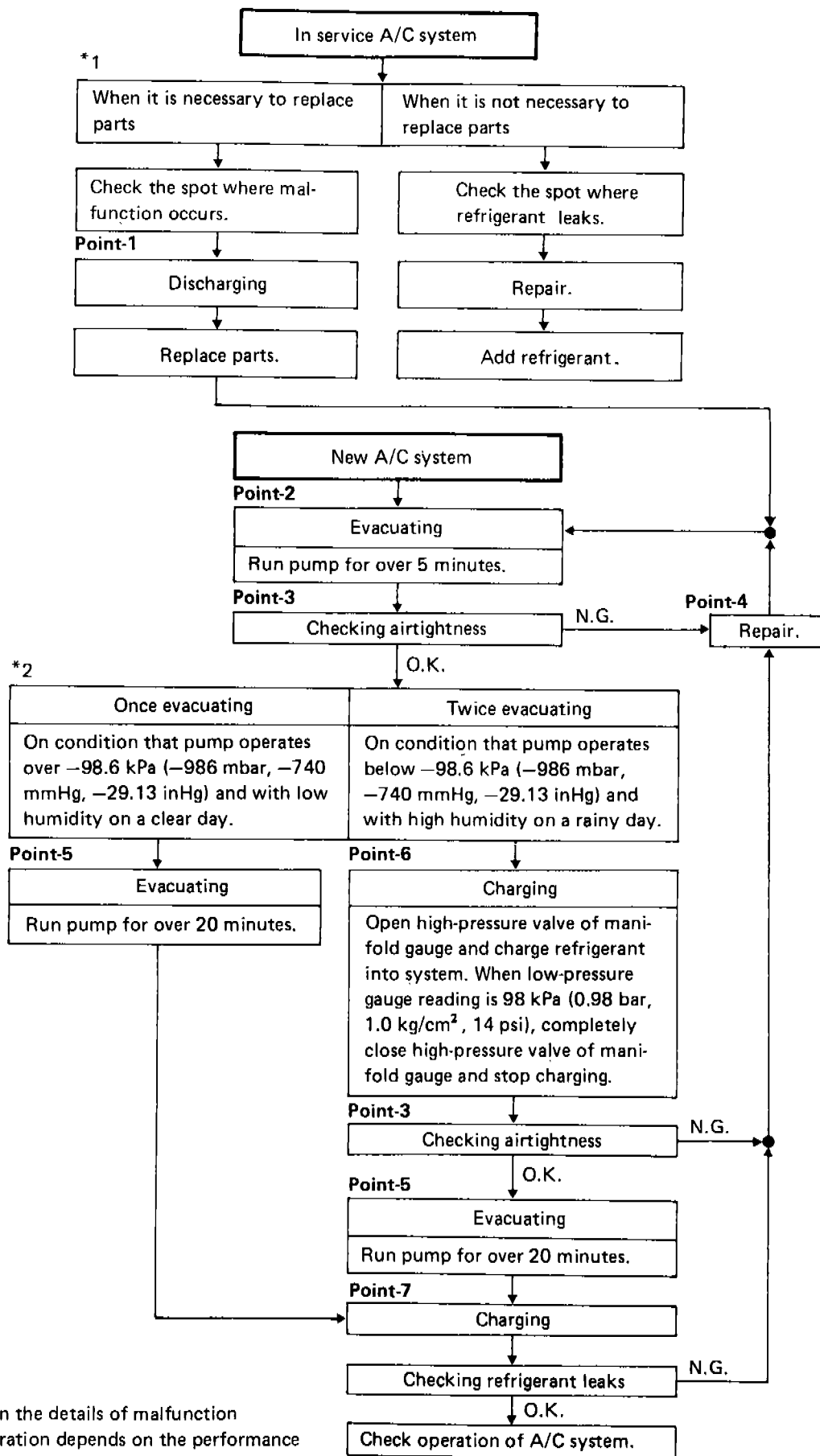

*1: Depending on the details of malfunction

*2: Working operation depends on the performance of the pump and the weather.

DISCHARGING, EVACUATING, CHARGING AND CHECKING

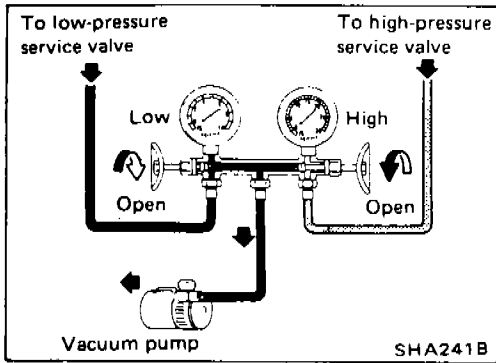
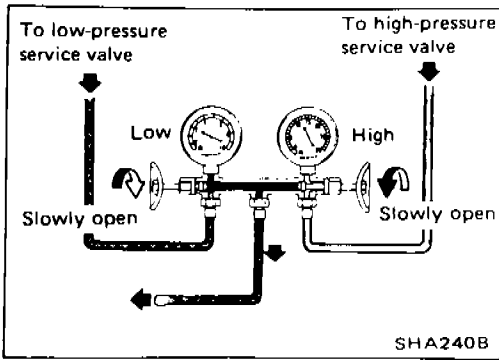

| Elevation m (ft) | Vacuum of system* kPa (mbar, mmHg, inHg) |
|---------------------|---------------------------------------------|
| 0 (0) | 101.3 (1,013, 760, 29.92) |
| 300 (1,000) | 98.0 (980, 735, 28.94) |
| 600 (2,000) | 94.6 (946, 710, 27.95) |
| 900 (3,000) | 91.3 (913, 685, 26.97) |

*: Values show reading of the low-pressure gauge.

Point-1

Discharging

Slowly open the valves to discharge only refrigerant. If they are opened quickly, compressor oil will also be discharged.

Point-2

Evacuating the System

1. Start pump, then open both valves and run pump for over 5 minutes.
2. When low gauge has reached approx. 98.6 to 101.3 kPa (986 to 1,013 mbar, 740 to 760 mmHg, 29.13 to 29.92 inHg), completely close both valves of gauge and stop vacuum pump.
 - a. The low-pressure gauge reads lower by 3.3 kPa (33 mbar, 25 mmHg, 0.98 inHg) per 300 m (1,000 ft) elevation. Perform evacuation according to the following table.
 - b. The rate ascension of the low-pressure gauge should be less than 3.3 kPa (33 mbar, 25 mmHg, 0.98 inHg) in 5 minutes.

Point-3

Checking Airtightness

1. Close both low and high-pressure valves and leave them unattended for approx. 5 to 10 minutes.
2. Make sure the pointer of the low-pressure gauge does not deflect toward the "0" direction.
3. If the pointer deflects, gas leakage is present. Repair as outlined under [Point-4](#).

Point-4

Repair

If a malfunction is noticed under [Point-3](#) above, locate and repair the leaking point using the following table as a guide.

| Leak at/around pipe connection | Leak at/around gauge manifold |
|---------------------------------------------------------------------------------------------------------------------------------------------------------------------------------------------------------------------------------------|------------------------------------------------------------------------------------------------------------------------------------------------------------------------------------------------|
| <ul style="list-style-type: none"> • O-ring fouled, damaged or deformed • Oil not applied to pipe connections during installation • Pipe connections not properly tightened (too tight or too loose) | <ul style="list-style-type: none"> • Malfunctioning charging hose • Gauge improperly installed • Malfunctioning valve • Malfunctioning packing, etc. |

DISCHARGING, EVACUATING, CHARGING AND CHECKING

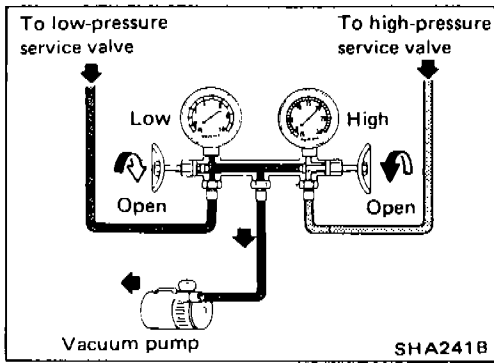

Point-5

Evacuating the System

1. Close manifold gauge valve securely and disconnect charging hose from refrigerant can.
2. Connect center charging hose to vacuum pump.
3. Start pump, then open both valves and run pump for over 20 minutes.

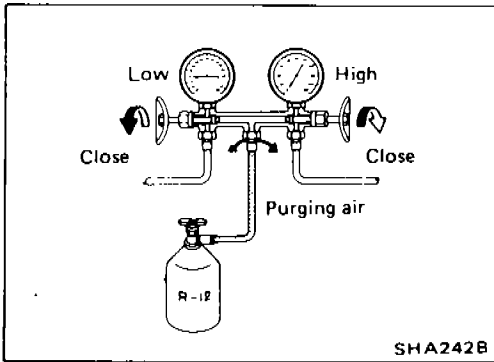

Point-6

Charging

1. Close manifold gauge valves securely and disconnect charging hose from vacuum pump.
2. Purge air from center charging hose.
 - 1) Connect center charging hose to refrigerant can through charge valve.
 - 2) Break seal of refrigerant can and purge air.

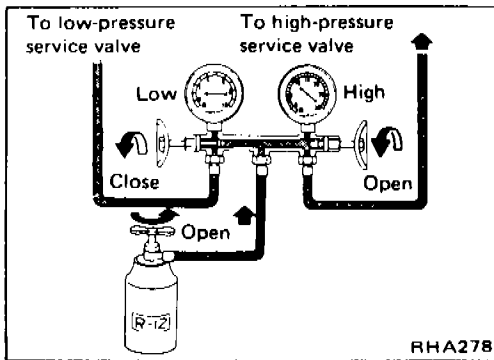

3. Charge refrigerant into system.

WARNING:

Ensure that engine is off.

- 1) Open high-pressure valve of manifold gauge and charge refrigerant into system.

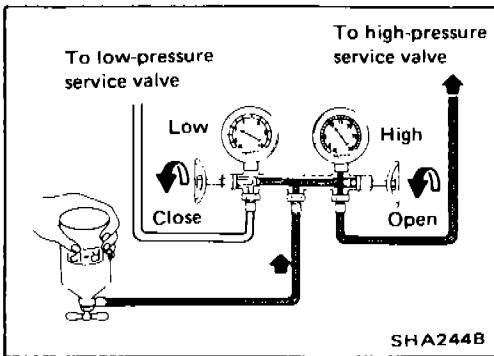

CAUTION:

If charging liquefied refrigerant into the system with the can turned upside down to reduce charging time, charge it only through high-pressure (discharge) service valve. After charging, the compressor should always be turned several times manually.

- 2) When low-pressure gauge reading is 98 kPa (0.98 bar, 1.0 kg/cm², 14 psi), completely close high-pressure valve of manifold gauge and stop charging.

DISCHARGING, EVACUATING, CHARGING AND CHECKING

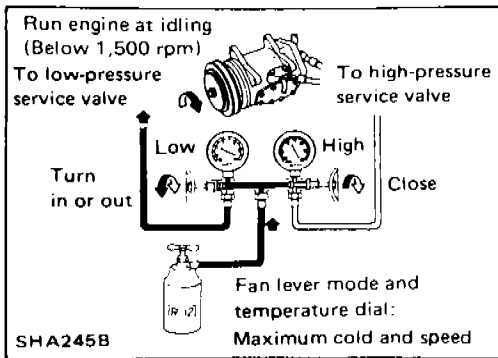

Point-7

Charging

1. Charge refrigerant into system.

WARNING:

Ensure that engine is off.

- Open low-pressure valve of manifold gauge and charge refrigerant into system.
2. When refrigerant charging speed slows down, close high-pressure valve of manifold gauge and open low-pressure valve of manifold gauge and charge it while running the compressor for ease of charging.
 3. Start engine — Air conditioning system ON, maximum temperature set, maximum blower speed. Open low-pressure valve on gauge set, with can in upright position, and monitor sight glass. Charge is complete when sight glass is clear.

Cycling clutch systems will produce bubbles in sight glass when clutch engages. Therefore, allow 5 seconds after clutch engages to determine if bubbles continue, and, if so, add refrigerant to clear sight glass.

WARNING:

Never charge refrigerant through high-pressure side (discharge side) of system since this will force refrigerant back into refrigerant can and can may explode.

4. Charge refrigerant while controlling low-pressure gauge reading at 275 kPa (2.75 bar, 2.8 kg/cm², 40 psi) or less by turning in or out low-pressure valve of manifold gauge.
- Be sure to purge air from charging hose when replacing can with a new one.

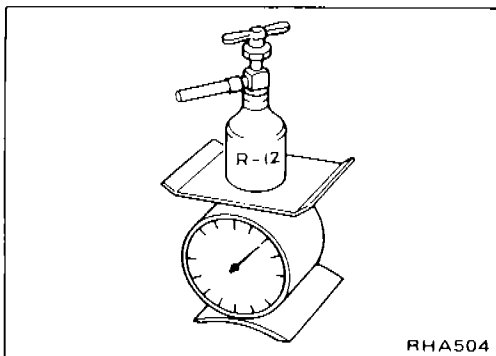

5. Charge the specified amount of refrigerant into system by weighing charged refrigerant with scale. Overcharging will cause discharge pressure to rise.

Refrigerant amount:

L.H.D. model

0.9 - 1.0 kg (2.0 - 2.2 lb)

R.H.D. model

0.8 - 0.9 kg (1.8 - 2.0 lb)

Point-7

Charging (Cont'd)

The state of the bubbles in sight glass can only be used for checking whether the amount of charged refrigerant is small or not. The amount of charged refrigerant should be correctly judged by means of discharge pressure.

6. After charging, be sure to install valve cap on service valve.
 7. Confirm that there are no leaks in system by checking with a leak detector.
- When refrigerant charging is performed with a charging cylinder, charging station, or automatic charging equipment, engine off, charge only through high side, after specified refrigerant amount has entered the system, close high-pressure valve on gauge set. Start engine return to idle speed, operate A/C at maximum temperature setting, high blower. Observe sight glass to confirm complete charge.

Overcharging will result in increased high pressures, and reduced performance.

DISCHARGING, EVACUATING, CHARGING AND CHECKING

Checking Refrigerant Level

CONDITION

- Door window: Open
- A/C switch: ON
- TEMP. lever position: Max. COLD
- FAN lever position: 4
- Check sight glass after a lapse of about five minutes.

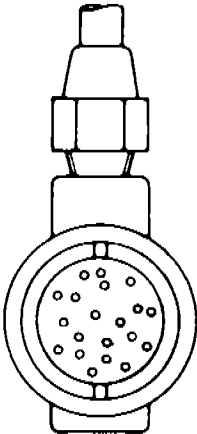
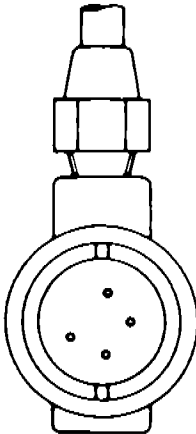
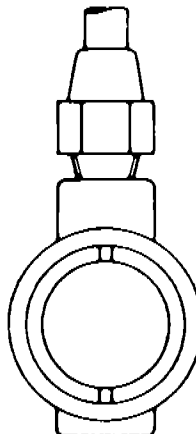
| Amount of refrigerant | Almost no refrigerant | Insufficient | Suitable | Too much refrigerant |
|------------------------------------------------------|----------------------------------------------------------------------------------------------------------------------|---------------------------------------------------------------------------------------------|-------------------------------------------------------------------------------------------------------------------------------------------------|--------------------------------------------------------------------|
| Check item | | | | |
| Temperature of high-pressure and low-pressure lines. | Almost no difference between high-pressure and low-pressure side temperature. | High-pressure side is warm and low-pressure side is fairly cold. | High-pressure side is hot and low-pressure side is cold. | High-pressure side is abnormally hot. |
| State in sight glass. | Bubbles flow continuously. Bubbles will disappear and something like mist will flow when refrigerant is nearly gone. | The bubbles are seen at intervals of 1 - 2 seconds. | Almost transparent. Bubbles may appear when engine speed is raised and lowered. No clear difference exists between these two conditions. | No bubbles can be seen. |
| |  AC256 |  AC257 |  AC258 | |
| Pressure of system. | High-pressure side is abnormally low. | Both pressures on high and low-pressure sides are slightly low. | Both pressures on high and low-pressure sides are normal. | Both pressures on high and low-pressure sides are abnormally high. |
| Repair. | Stop compressor immediately and conduct an overall check. | Check for gas leakage, repair as required, replenish and charge system. | | Discharge refrigerant from service valve of low pressure side. |

a. The bubbles seen through the sight glass are influenced by the ambient temperature. Since the bubbles are hard to show up in comparatively low temperatures below 20°C (68°F), it is possible that a slightly larger amount of refrigerant would be filled, if supplied according to the sight glass. Recheck the amount when it

exceeds 20°C (68°F). In higher temperature the bubbles are easy to show up.

b. When the screen in the receiver drier is clogged, the bubbles will appear even if the amount or refrigerant is normal. In this case, the outlet side pipe of the receiver drier becomes considerably cold.

DISCHARGING, EVACUATING, CHARGING AND CHECKING

Nominal sensitivity:
15 - 25 g (0.53 - 0.88 oz)/year

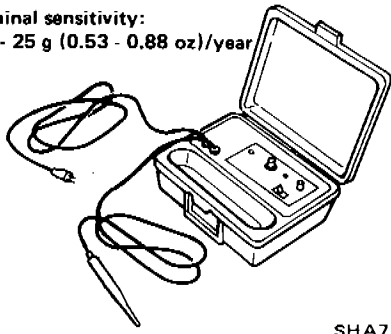

SHA733A

Checking Refrigerant Leaks

ELECTRIC LEAK DETECTOR

The leak detector is a delicate device that detects small amounts of halogen.

To use the device properly, read the manufacturer's manuals. Also perform the specified maintenance and inspections.

UNION TYPE

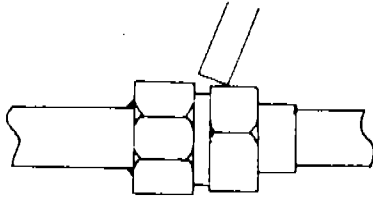

RHA279

GENERAL PRECAUTIONS FOR HANDLING LEAK DETECTOR

Place the probe on connection fitting and wait for 5 seconds or more.

To check cooling unit, wait for 10 seconds or more.

Keep the probe as still as possible for one more minute.

PLATE TYPE

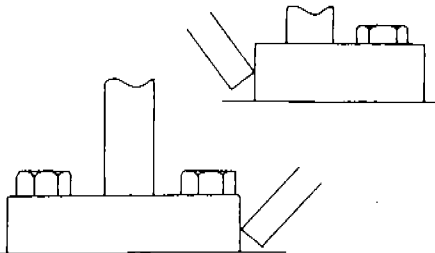

RHA280

When testing single-bolt flange, place the probe on the opposite side of the fitting.

MEASUREMENT STANDARD

If any leak is noted with a detector having a nominal sensitivity of 15 to 25 g (0.53 to 0.88 oz)/year, that leak must be repaired.

- The nominal sensitivity of the detector is determined under the assumption that all the leaking gas is collected by the detector. Accordingly, the quantity of gas actually leaking can amount to five to ten times the indicated value. Generally speaking, leakage of 150 to 200 g (5.29 to 7.05 oz) of refrigerant can cause insufficient cooling.
- Oil deposited during assembling must be wiped off before inspection. Refrigerant easily dissolves in oil, and the presence of oil can cause an error in measurement. This precaution is important when checking a used car for refrigerant leakage.
- If oil is noted at or around connections, it indicates that refrigerant is leaking.

DESCRIPTION OF AIR CONDITIONER

Acceleration Cut System

This system is controlled by the E.C.C.S. control unit. When the engine is heavily overloaded (throttle sensor judges that throttle valve is at full throttle position or engine speed is more than 6,500 rpm), the compressor is turned off for approx. 5 seconds to reduce overloading.

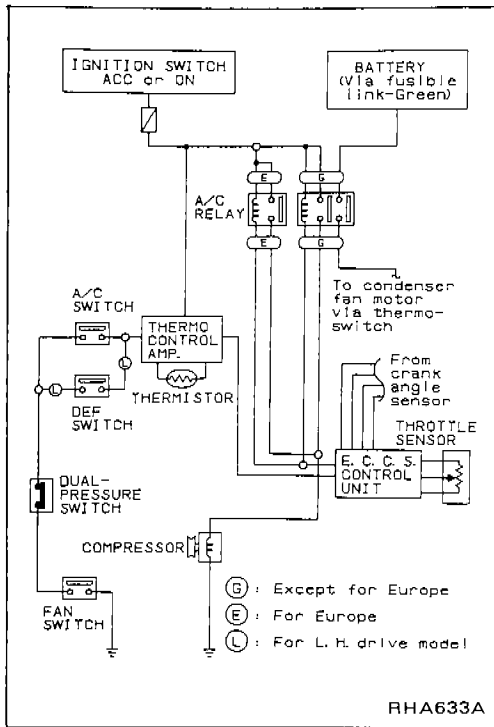

DESCRIPTION OF AIR CONDITIONER

Refrigeration Cycle

REFRIGERANT FLOW

The refrigerant flows in the standard pattern, that is, through the compressor, the condenser, the receiver drier, through the evaporator, and back to the compressor.

The refrigerant evaporation through the evaporator coil is controlled by an externally equalized expansion valve, located inside the evaporator case.

FREEZE PROTECTION

The compressor cycles on and off to maintain the evaporator temperature within a specified range. When the evaporator coil temperature falls below a specified point, the thermo control amplifier interrupts the compressor operation. When the evaporator coil temperature rises above the specification, the thermo control amplifier allows compressor operation.

REFRIGERANT SYSTEM PROTECTION

Dual-pressure switch

The refrigerant system is protected against excessively high or low pressures by the dual-pressure switch, located on the receiver drier. If the system pressure rises above, or falls below the specifications, the dual-pressure switch opens to interrupt the compressor operation.

Fusible plug

Open at temperature above 105°C (221°F), thereby discharging refrigerant to the atmosphere. If this plug is melted and opened, check the refrigerant line and replace receiver drier.

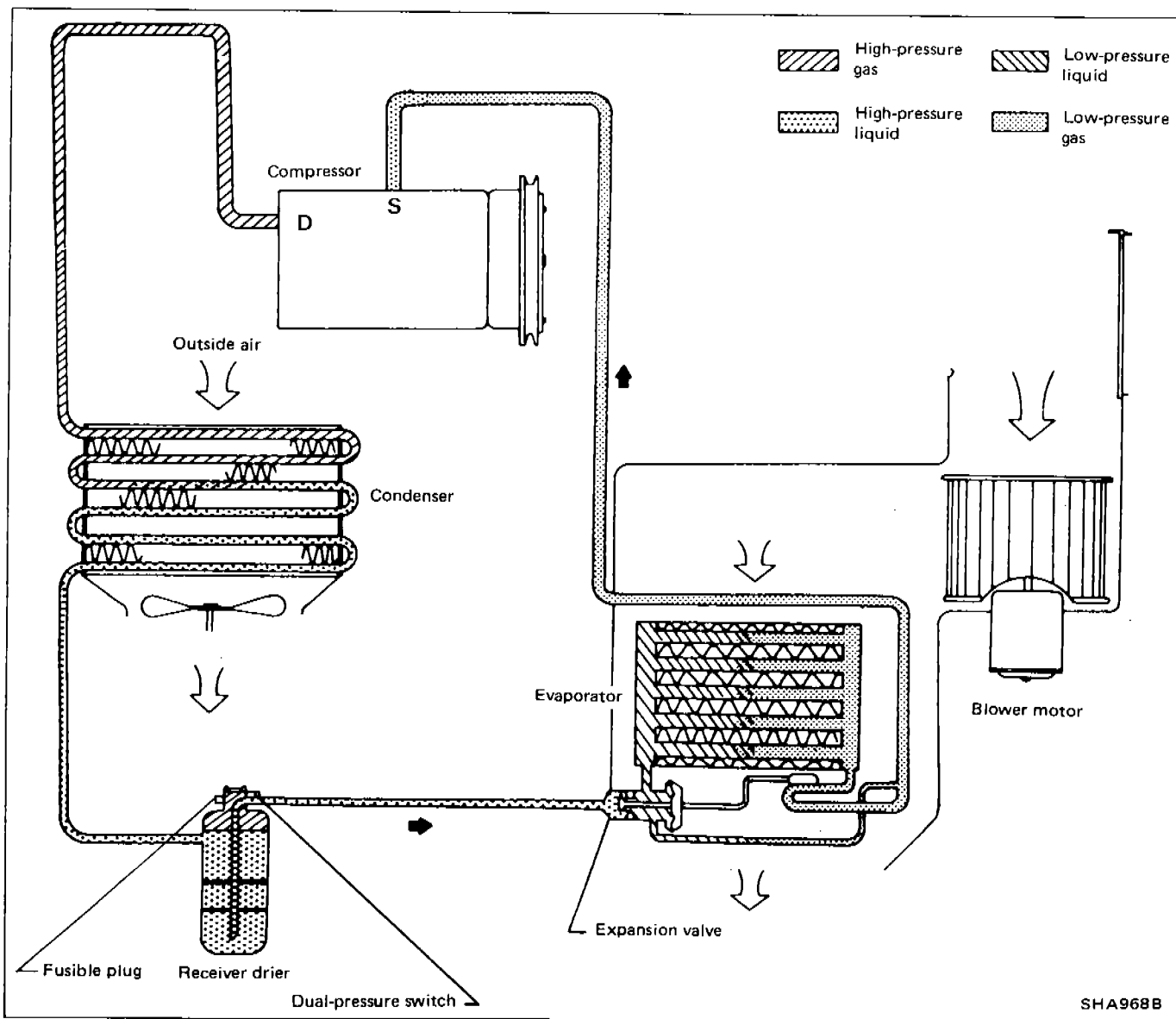

SERVICE PROCEDURES

Refrigerant Lines

L.H.D. MODEL

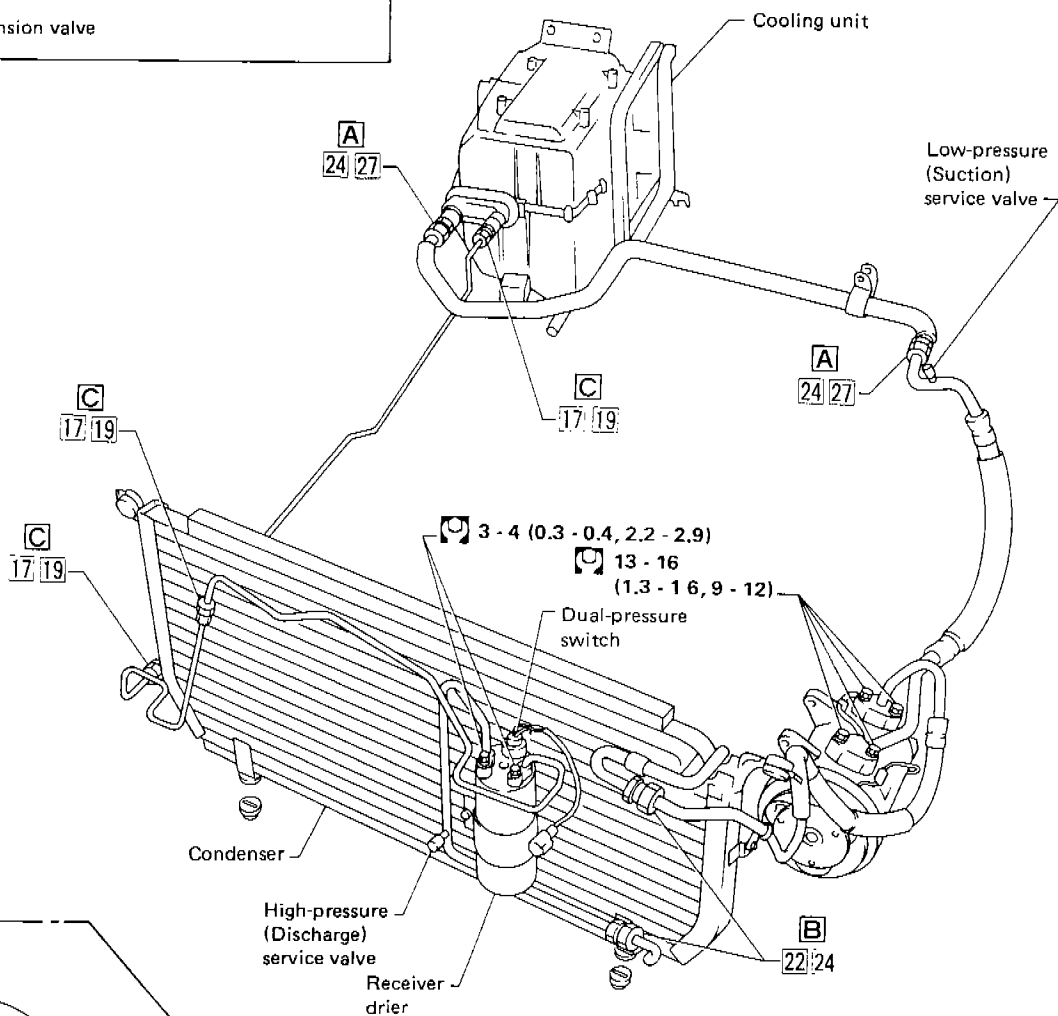
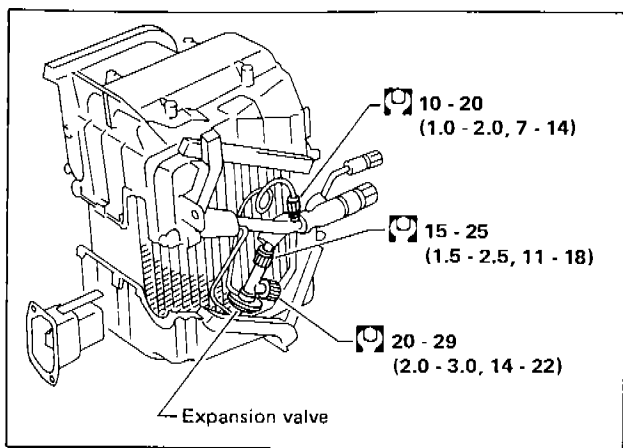

- (Tightening torque)
- (Wrench size)
- A 20 - 29 (2.0 - 3.0, 14 - 22)
- B 15 - 25 (1.5 - 2.5, 11 - 18)
- C 10 - 20 (1.0 - 2.0, 7 - 14)

⊙ : N·m (kg·m, ft·lb)
RHA634A

HA-30

SERVICE PROCEDURES

Refrigerant Lines (Cont'd)

R.H.D. MODEL

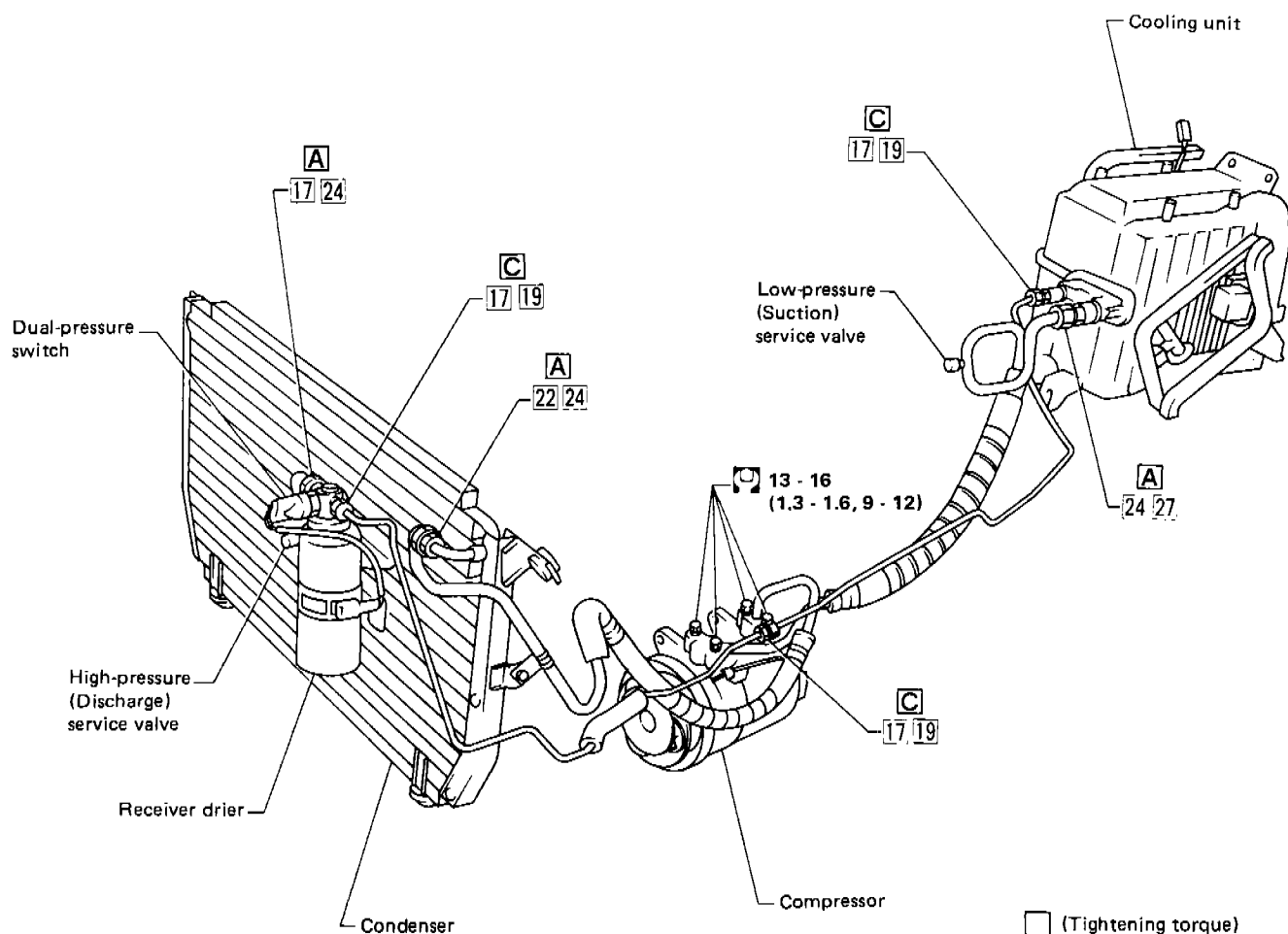
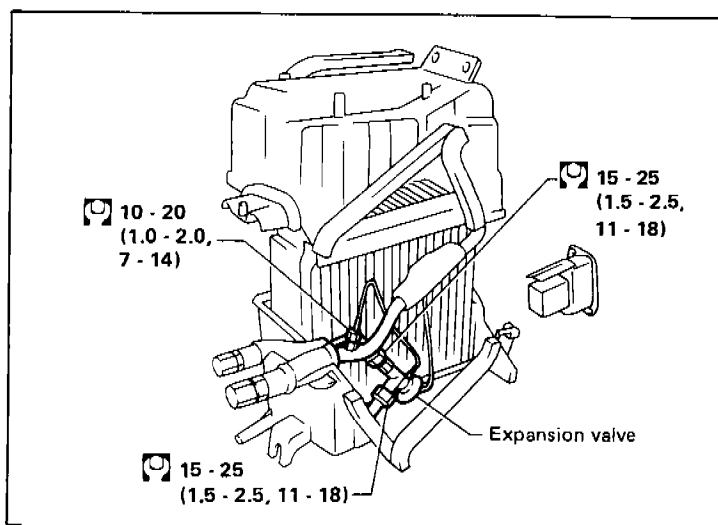

- (Tightening torque)
- (Wrench size)
- A** 20 - 29 (2.0 - 3.0, 14 - 22)
- B** 15 - 25 (1.5 - 2.5, 11 - 18)
- C** 10 - 20 (1.0 - 2.0, 7 - 14)
- ⊞ : N-m (kg-m, ft-lb)

RHA635A

SERVICE PROCEDURES

Compressor Mounting

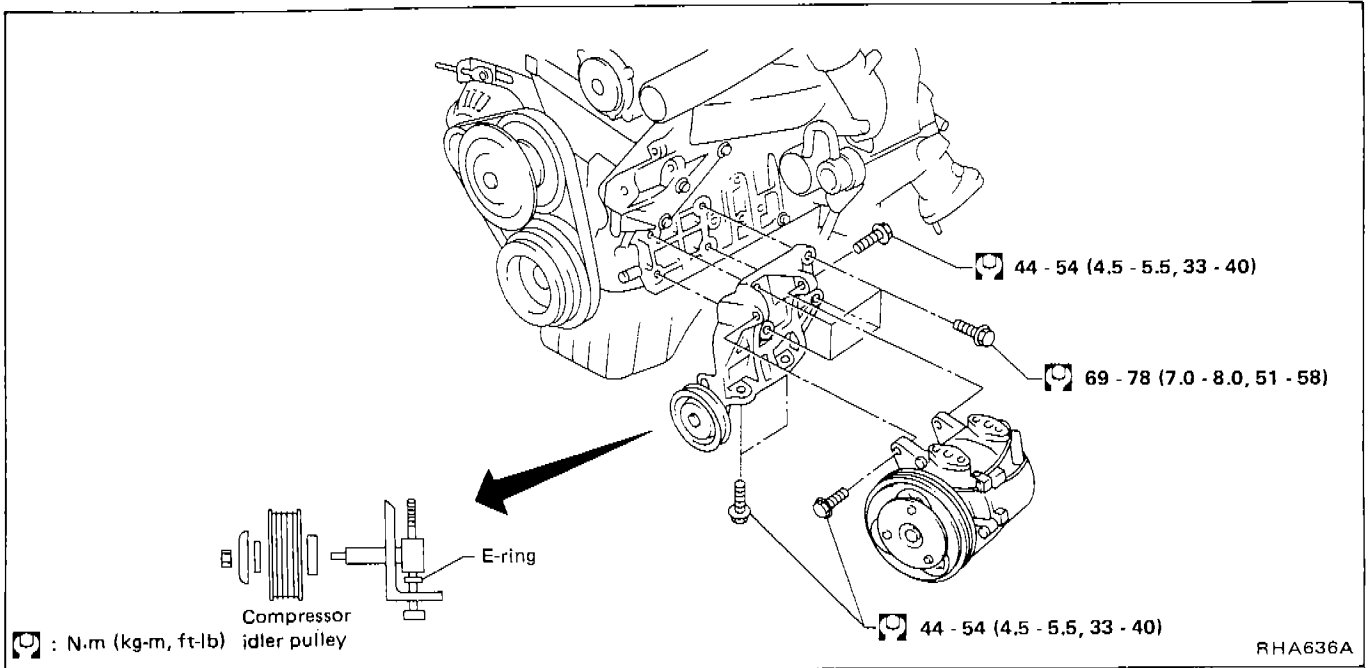

L.H.D.
model

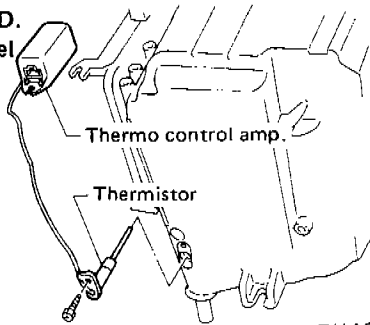

Thermo Control Amp.

REPLACEMENT

Remove screws, which secure thermistor locating stay, from front of cooling unit. Replace thermo control amp. assembly with a new one. (Cooling unit need not be removed during the replacement.)

R.H.D.
model

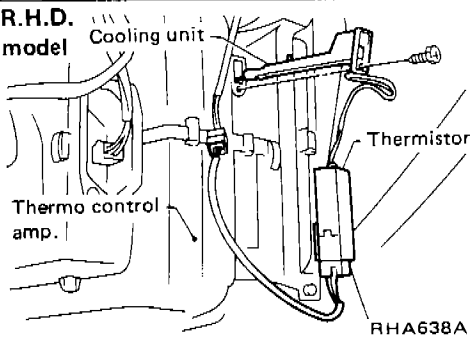

Belt Tension

- Refer to MA section.

Fast Idle Control Device (F.I.C.D.)

- Refer to EF & EC section.

A/C PERFORMANCE TEST

Performance Chart

TEST CONDITION

Testing must be performed as follows:

Vehicle location: Indoors or in the shade (in a well ventilated place)

Doors: Closed

Door window: Open

Hood: Open

TEMP. lever position: Max. COLD

Air control lever position:  (Ventilation)

INTAKE lever position:  (Recirculation)

FAN lever position: Max. position

Engine speed: 1,500 rpm

Time required before starting testing after air conditioner starts operating: More than 10 minutes

For hot areas, make sure that condenser fan motor does not operate during the following tests.

TEST READING

L.H.D. model

Recirculating-to-discharge air temperature table

| Inside air (Recirculating air) at blower assembly inlet | | Discharge air temperature at center ventilator °C (°F) |
|------------------------------------------------------------|----------------------------|-----------------------------------------------------------|
| Relative humidity % | Air temperature °C (°F) | |
| 50 - 60 | 20 (68) | 1.6 - 2.7 (35 - 37) |
| | 25 (77) | 4.4 - 6.0 (40 - 43) |
| | 30 (86) | 9.2 - 11.3 (49 - 52) |
| | 35 (95) | 14.8 - 17.0 (59 - 63) |
| | 40 (104) | 18.1 - 20.3 (65 - 69) |
| 60 - 70 | 20 (68) | 2.7 - 4.3 (37 - 40) |
| | 25 (77) | 6.0 - 8.2 (43 - 47) |
| | 30 (86) | 11.3 - 13.8 (52 - 57) |
| | 35 (95) | 17.0 - 19.5 (63 - 67) |
| | 40 (104) | 20.3 - 22.8 (69 - 73) |

Ambient air temperature-to-compressor pressure table

| Ambient air | | High-pressure (Discharge side) kPa (bar, kg/cm ² , psi) | Low-pressure (Suction side) kPa (bar, kg/cm ² , psi) |
|------------------------|----------------------------|-----------------------------------------------------------------------|--------------------------------------------------------------------|
| Relative humidity % | Air temperature °C (°F) | | |
| 50 - 70 | 20 (68) | 1,030 - 1,255 (10.30 - 12.55, 10.5 - 12.8, 149 - 182) | 98.1 - 142.2 (0.981 - 1.422, 1.0 - 1.45, 14.2 - 20.6) |
| | 25 (77) | 1,196 - 1,471 (11.96 - 14.71, 12.2 - 15.0, 173 - 213) | 122.6 - 171.6 (1.226 - 1.716, 1.25 - 1.75, 17.8 - 24.9) |
| | 30 (86) | 1,402 - 1,706 (14.02 - 17.06, 14.3 - 17.4, 203 - 247) | 161.8 - 210.9 (1.618 - 2.109, 1.65 - 2.15, 23.5 - 30.6) |
| | 35 (95) | 1,608 - 1,971 (16.08 - 19.71, 16.4 - 20.1, 233 - 286) | 205.9 - 259.9 (2.059 - 2.599, 2.1 - 2.65, 29.9 - 37.7) |
| | 40 (104) | 1,844 - 2,256 (18.44 - 22.56, 18.8 - 23.0, 267 - 327) | 259.9 - 318.7 (2.599 - 3.187, 2.65 - 3.25, 37.7 - 46.2) |

HA-33

A/C PERFORMANCE TEST

Performance Chart (Cont'd)

R.H.D. model

Recirculating-to-discharge air temperature table

| Inside air (Recirculating air) at blower assembly inlet | | Discharge air temperature at center ventilator °C (°F) |
|------------------------------------------------------------|----------------------------|-----------------------------------------------------------|
| Relative humidity % | Air temperature °C (°F) | |
| 50 - 60 | 20 (68) | 1.5 - 2.5 (35 - 37) |
| | 25 (77) | 4.0 - 6.0 (39 - 43) |
| | 30 (86) | 9.0 - 12.0 (48 - 54) |
| | 35 (95) | 14.5 - 18.0 (58 - 64) |
| | 40 (104) | 20.5 - 23.0 (69 - 73) |
| 60 - 70 | 20 (68) | 2.5 - 4.5 (37 - 40) |
| | 25 (77) | 6.0 - 9.0 (43 - 48) |
| | 30 (86) | 12.0 - 14.5 (54 - 58) |
| | 35 (95) | 18.0 - 21.0 (64 - 70) |
| | 40 (104) | 23.0 - 26.0 (73 - 79) |

Ambient air temperature-to-compressor pressure table

| Ambient air | | High-pressure (Discharge side) kPa (bar, kg/cm ² , psi) | Low-pressure (Suction side) kPa (bar, kg/cm ² , psi) |
|------------------------|----------------------------|-----------------------------------------------------------------------|--------------------------------------------------------------------|
| Relative humidity % | Air temperature °C (°F) | | |
| 50 - 70 | 20 (68) | 922 - 1,304 (9.22 - 13.04, 9.4 - 13.3, 134 - 189) | 107.9 - 171.6 (1.079 - 1.716, 1.1 - 1.75, 15.6 - 24.9) |
| | 25 (77) | 1,098 - 1,520 (10.98 - 15.20, 11.2 - 15.5, 159 - 220) | 127.5 - 201.0 (1.275 - 2.010, 1.3 - 2.05, 18.5 - 29.2) |
| | 30 (86) | 1,314 - 1,775 (13.14 - 17.75, 13.4 - 18.1, 191 - 257) | 156.9 - 235.4 (1.569 - 2.354, 1.6 - 2.4, 22.8 - 34.1) |
| | 35 (95) | 1,550 - 2,059 (15.50 - 20.59, 15.8 - 21.0, 225 - 299) | 196 - 284 (1.96 - 2.84, 2.0 - 2.9, 28 - 41) |
| | 40 (104) | 1,804 - 2,373 (18.04 - 23.73, 18.4 - 24.2, 262 - 344) | 245 - 343 (2.45 - 3.43, 2.5 - 3.5, 36 - 50) |

A/C PERFORMANCE TEST

Performance Test Diagnoses

Characteristics revealed by the manifold gauge readings for the air conditioning system are shown in the following.

For how to do the performance test, refer to the item "Performance Chart".

In the following table, the portion smeared with ink on each gauge scale indicates the range showing that the air conditioning system is in good order. This range is described in Performance Chart.

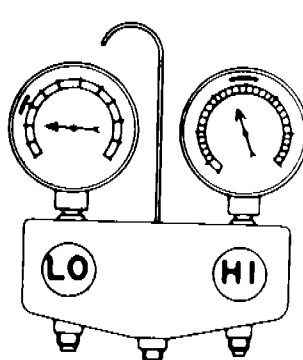
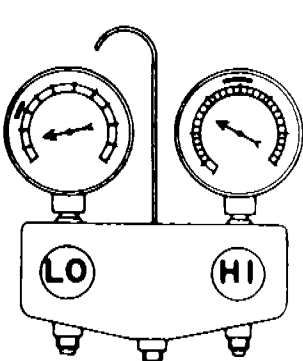
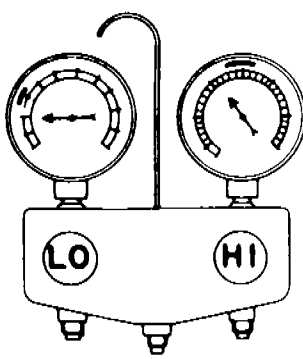
| Condition | Probable cause | Corrective action |
|----------------------------------------------------------------------------------------------------------------------------------------------------------------------------------------------------------------------------------------------------------------------------------------------------------------------------|-----------------------------------------------------------------------------------------------------------------------------------------------------------------------------------------------------------------------------------------------------------------------------------------------------------------------------------------|-------------------------------------------------------------------------------------------------------------------------------------------------------------------------------------------------------------------------------------------------------------------------------------------------------------------------------------------------------------------------------------------------------------------------------------------|
| <p data-bbox="95 515 606 560">INSUFFICIENT REFRIGERANT CHARGE</p>  <p data-bbox="383 940 478 963">AC352A</p> <p data-bbox="494 582 766 694">Insufficient cooling. Bubbles appear in sight glass.</p> | <p data-bbox="813 582 1053 649">Refrigerant is low, or leaking slightly.</p> | <p data-bbox="1133 582 1340 683">1. Leak test. 2. Repair leak. 3. Charge system.</p> <p data-bbox="1133 694 1436 761">Evacuate, as necessary, and recharge system.</p> |
| <p data-bbox="95 985 462 1030">ALMOST NO REFRIGERANT</p>  <p data-bbox="383 1411 478 1433">AC353A</p> <p data-bbox="494 1052 734 1209">No cooling action. A lot of bubbles or something like mist appears in sight glass.</p> | <p data-bbox="813 1052 1069 1097">Serious refrigerant leak.</p> | <p data-bbox="1133 985 1420 1064">Stop compressor immediately.</p> <p data-bbox="1133 1064 1436 1321">1. Leak test. 2. Discharge system. 3. Repair leak(s). 4. Replace receiver drier if necessary. 5. Check oil level. 6. Evacuate and recharge system.</p> |
| <p data-bbox="95 1456 606 1500">MALFUNCTIONING EXPANSION VALVE</p>  <p data-bbox="383 1926 478 1948">AC354A</p> <p data-bbox="494 1523 734 1635">Slight cooling. Sweat or frosting on expansion valve inlet.</p> | <p data-bbox="813 1523 1085 1590">Expansion valve restricts refrigerant flow.</p> <ul data-bbox="813 1590 1085 1713" style="list-style-type: none"> • Expansion valve is clogged. • Expansion valve is inoperative. <p data-bbox="861 1713 1085 1814">Valve stuck closed. Thermal bulb has lost charge.</p> | <p data-bbox="1133 1523 1420 1590">If valve inlet reveals sweat or frost:</p> <p data-bbox="1133 1590 1452 1747">1. Discharge system. 2. Remove valve and clean it. Replace it if necessary. 3. Evacuate system. 4. Charge system.</p> <p data-bbox="1133 1758 1420 1792">If valve does not operate:</p> <p data-bbox="1133 1792 1388 1915">1. Discharge system. 2. Replace valve. 3. Evacuate and charge system.</p> |

A/C PERFORMANCE TEST

Performance Test Diagnoses (Cont'd)

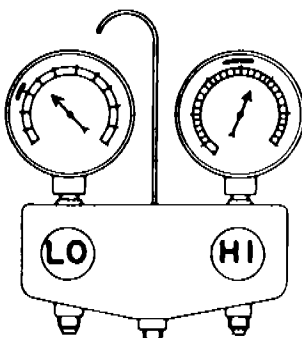
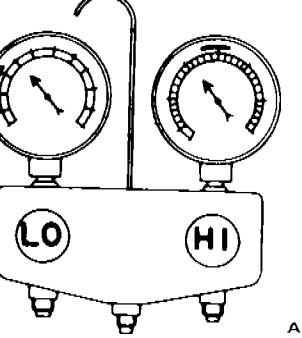
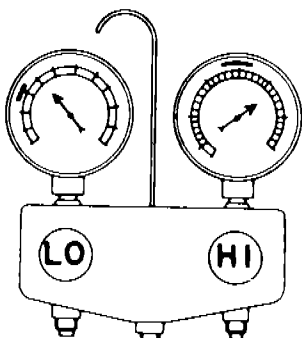
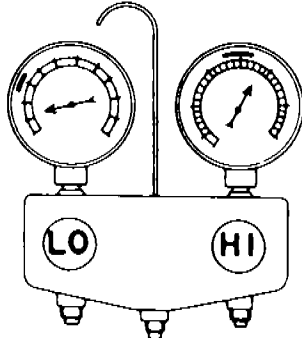
| Condition | Probable cause | Corrective action |
|---------------------------------------------------------------------------------------------------|--------------------------------------------------------------------------------------------------------------------------------------------------------------------------------------------------------------------------------|-------------------------------------------------------------------------------------------------------------------------------------------------------------------------------------------------------------------------------------------------------------------------------------------------------------------------------------------------------------------|
|  <p>AC355A</p> | <p>Insufficient cooling. Sweat on suction line.</p> | <p>Expansion valve allows too much refrigerant through evaporator.</p> <p>Check valve for operation. If suction side does not show a pressure decrease, replace valve.</p> |
|  <p>AC356A</p> | <p>No cooling. Sweat or frosting on suction line.</p> | <p>Malfunctioning expansion valve.</p> <ol style="list-style-type: none"> 1. Discharge system. 2. Replace valve. 3. Evacuate and charge system. |
| <p>AIR IN SYSTEM</p> | | |
|  <p>AC359A</p> | <p>Insufficient cooling. Sight glass shows occasional bubbles.</p> | <p>Air mixed with refrigerant in system.</p> <ol style="list-style-type: none"> 1. Discharge system. 2. Replace receiver drier. 3. Evacuate and charge system. |
| <p>MOISTURE IN SYSTEM</p> | | |
|  <p>AC360A</p> | <p>After short operation, suction side may show vacuum pressure reading. During this condition, discharge air will be warm. As a warning of this, reading vibrates around 39 kPa (0.39 bar, 0.4 kg/cm², 6 psi).</p> | <p>Drier is saturated with moisture. Moisture has frozen in expansion valve. Refrigerant flow is restricted.</p> <ol style="list-style-type: none"> 1. Discharge system. 2. Replace receiver drier (twice if necessary). 3. Evacuate system completely. (Repeat 30-minutes evacuating three times.) 4. Recharge system. |

A/C PERFORMANCE TEST

Performance Test Diagnoses (Cont'd)

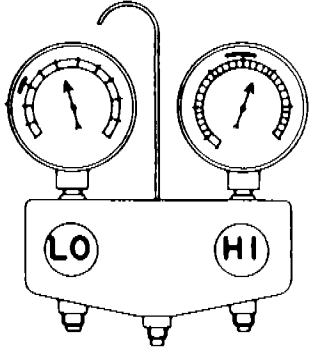
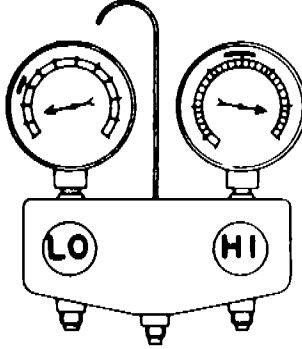
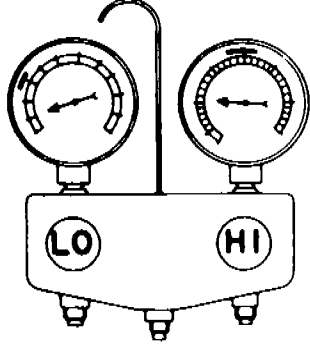
| Condition | Probable cause | Corrective action |
|-----------------------------------------------------------------------------------------------------------------------------------------------------------------------------------------------------------------------------------------------------------------|---------------------------------------------------------------------|---------------------------------------------------------------------------------------------------------------------------------------------------------------------------------------------------------------------------------------------------------------------------------------------------------------------------------------------------------------------------------------------------------------------------------------------|
| <p>MALFUNCTIONING CONDENSER</p> <p>No cooling action: engine may overheat. Bubbles appear in sight glass of drier. Suction line is very hot.</p>  <p>AC361A</p> | <p>Usually a malfunctioning condenser.</p> | <ul style="list-style-type: none"> • Check fan belt and fluid coupling. • Check condenser fan motor (For hot areas only). • Check condenser for dirt accumulation. • Check engine cooling system for overheating. • Check for refrigerant overcharging. <p>If pressure remains high in spite of all above actions taken, remove and inspect the condenser for possible oil clogging.</p> |
| <p>HIGH-PRESSURE LINE BLOCKED</p> <p>Insufficient cooling. Frosted high-pressure liquid line.</p>  <p>AC362A</p> | <p>Drier clogged, or restriction in high-pressure line.</p> | <ol style="list-style-type: none"> 1. Discharge system. 2. Remove receiver drier or strainer and replace it. 3. Evacuate and charge system. |
| <p>MALFUNCTIONING COMPRESSOR</p> <p>Insufficient cooling.</p>  <p>AC363A</p> | <p>Internal problem in compressor, or damaged gasket and valve.</p> | <ol style="list-style-type: none"> 1. Discharge system. 2. Remove and check compressor. 3. Repair or replace compressor. 4. Check oil level. 5. Replace receiver drier. 6. Evacuate and charge system. |

A/C PERFORMANCE TEST

Performance Test Diagnoses (Cont'd)

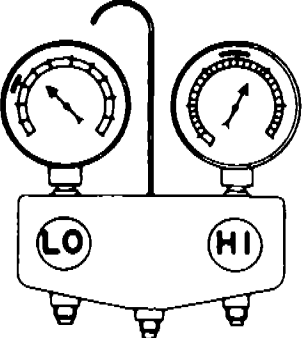
| Condition | Probable cause | Corrective action |
|----------------------------------------------------------------------------------------------------------------------------------------------------------------------------------------------------------|----------------------------------------------------------|---------------------------------------------------------------------------------------------------------------------------------------------------------------------------------------------------------------------------------------|
| <p data-bbox="132 257 375 320">TOO MUCH OIL IN SYSTEM (Excessive)</p>  <p data-bbox="419 757 502 779">AC364A</p> | <p data-bbox="534 257 746 291">Insufficient cooling.</p> | <p data-bbox="850 257 1137 387">Too much oil circulates with refrigerant, causing the cooling capacity of the system to be reduced.</p> <p data-bbox="1169 257 1489 324">Refer to COMPRESSOR OIL for correcting oil level.</p> |

COMPRESSOR OIL — For NVR 140S (ATSUGI make)

Checking and Adjusting

The oil used to lubricate the compressor is circulating with the refrigerant.

Whenever replacing any component of the system or a large amount of gas leakage occurs, add oil to maintain the original amount of oil.

OIL CAPACITY

| | Unit: ml (Imp fl oz) |
|--------------------------------------------|----------------------|
| Applied model | All models |
| Capacity | |
| Total in system | 200 (7.0) |
| Amount of oil which can be drained | Approx. 100 (3.5)* |
| Compressor (Service parts) charging amount | 200 (7.0) |

*: All oil cannot be drained from system.

OIL RETURN OPERATION

Before checking and adjusting oil level, operate compressor at engine idling speed, with controls set for maximum cooling and high blower speed, for 20 to 30 minutes in order to return oil to compressor.

CHECKING AND ADJUSTING FOR USED COMPRESSOR

1. After oil return operation, stop the engine and discharge refrigerant and then remove compressor from the vehicle.
2. Drain compressor oil from compressor discharge port and measure the amount.

Oil is sometimes hard to extract when compressor is cooled. Remove oil while compressor is warm [maintained to 40 to 50°C (104 to 122°F)].

3. If the amount is less than 90 ml (3.2 Imp fl oz), some refrigerant may have leaked out. Conduct leak tests on connections of each system, and if necessary, repair or replace faulty parts.

4. Check the purity of the oil and then adjust oil level following the procedure below.
 - (a) When oil is clean;

Unit: ml (Imp fl oz)

| Amount of oil drained | Adjusting procedure |
|-----------------------|-----------------------------------------------------------------------|
| Above 90 (3.2)* | Oil level is right. Pour in same amount of oil as was drained out. |
| Below 90 (3.2) | Oil level may be low. Pour in 90 ml (3.2 Imp fl oz) of oil. |

*: If amount of oil drained is much greater than under normal circumstances, flush air conditioner system with refrigerant. Then pour 200 ml (7.0 Imp fl oz) of oil into air conditioner system.

- (b) When oil contains chips or foreign material; After air conditioner system has been flushed with refrigerant, replace receiver drier. Then pour 200 ml (7.0 Imp fl oz) of oil into air conditioner system.

CHECKING AND ADJUSTING FOR COMPRESSOR REPLACEMENT

200 ml (7.0 Imp fl oz) of oil is charged in compressor (service parts). So it is necessary to drain the proper amount of oil from new compressor. Follow the procedure below.

1. After oil return operation, drain compressor oil from used compressor and measure the amount.

(It is the same procedure as CHECKING AND ADJUSTING FOR USED COMPRESSOR.)

COMPRESSOR OIL — For NVR 140S (ATSUGI make)

Checking and Adjusting (Cont'd)

2. Check the purity of the oil and then adjust oil level following the procedure below.

(a) When oil is clean;

Unit: mL (Imp fl oz)

| Amount of oil drained from used compressor | Draining amount of oil from new compressor |
|--------------------------------------------|------------------------------------------------|
| Above 90 (3.2)* | 200 (7.0) — [Amount of oil drained + 20 (0.7)] |
| Below 90 (3.2) | 90 (3.2) |

*: If amount of oil drained is greater than under normal circumstances, flush air conditioner system with refrigerant. Then install new compressor. [200 mL (7.0 Imp fl oz) of oil is changed in compressor service parts.]

Example:

Unit: mL (Imp fl oz)

| Amount of oil drained from used compressor | Draining amount of oil from new compressor |
|--------------------------------------------|--------------------------------------------|
| 110 (3.9) | 70 (2.5) |
| 70 (2.5) | 90 (3.2) |

- (b) When oil contains chips or foreign material; After air conditioner system has been flushed with refrigerant, replace receiver drier. Then install new compressor. [200 mL (7.0 Imp fl oz) of oil is changed in compressor service parts.]

Checking and Adjusting

The oil used to lubricate the compressor is circulating with the refrigerant.

Whenever replacing any component of the system or a large amount of gas leakage occurs, add oil to maintain the original amount of oil.

OIL CAPACITY

| | Unit: ml (Imp fl oz) |
|--------------------------------------------|--------------------------|
| Applied model | All models |
| Capacity | |
| Total in system | 200 (7.0) |
| Amount of oil which can be drained | 70 - 120 (2.5 - 4.2)* |
| Compressor (Service parts) charging amount | 200 (7.0) |

*: All oil cannot be drained from system.

OIL RETURN OPERATION

Before checking and adjusting oil level, operate compressor at engine idling speed, with controls set for maximum cooling and high blower speed, for 20 to 30 minutes in order to return oil to compressor.

CHECKING AND ADJUSTING FOR USED COMPRESSOR

1. After oil return operation, stop the engine and discharge refrigerant and then remove compressor from the vehicle.
2. Drain compressor oil from compressor discharge port and measure the amount.

Oil is sometimes hard to extract when compressor is cooled. Remove oil while compressor is warm [maintained to 40 to 50°C (104 to 122°F)].

3. If the amount is less than 70 ml (2.5 Imp fl oz), some refrigerant may have leaked out. Conduct leak tests on connections of each system, and if necessary, repair or replace faulty parts.

4. Check the purity of the oil and then adjust oil level following the procedure below.

(a) When oil is clean;

Unit: ml (Imp fl oz)

| Amount of oil drained | Adjusting procedure |
|-----------------------|-----------------------------------------------------------------------|
| Above 70 (2.5)* | Oil level is right. Pour in same amount of oil as was drained out. |
| Below 70 (2.5) | Oil level may be low. Pour in 70 ml (2.5 Imp fl oz) of oil. |

*: If amount of oil drained is much greater than under normal circumstances, flush air conditioner system with refrigerant. Then pour 200 ml (7.0 Imp fl oz) of oil into air conditioner system.

(b) When oil contains chips or other foreign material;

After air conditioner system has been flushed with refrigerant, replace receiver drier. Then pour 200 ml (7.0 Imp fl oz) of oil into air conditioner system.

CHECKING AND ADJUSTING FOR COMPRESSOR REPLACEMENT

200 ml (7.0 Imp fl oz) of oil is charged in compressor (service parts). So it is necessary to drain the proper amount of oil from new compressor. Follow the procedure below.

1. After oil return operation, drain compressor oil from used compressor and measure the amount.

(It is the same procedure as CHECKING AND ADJUSTING FOR USED COMPRESSOR.)

COMPRESSOR OIL—For DKV-14C (DIESEL-KIKI make)

Checking and Adjusting (Cont'd)

2. Check the purity of the oil and then adjust oil level following the procedure below.

(a) When oil is clean;

Unit: mL (Imp fl oz)

| Amount of oil drained from used compressor | Draining amount of oil from new compressor |
|--------------------------------------------|------------------------------------------------|
| Above 70 (2.5)* | 200 (7.0) – [Amount of oil drained + 20 (0.7)] |
| Below 70 (2.5) | 110 (3.9) |

*: If amount of oil drained is greater than under normal circumstances, flush air conditioner system with refrigerant. Then install new compressor. [200 mL (7.0 Imp fl oz) of oil is charged in compressor service parts.]

Example:

Unit: mL (Imp fl oz)

| Amount of oil drained from used compressor | Draining amount of oil from new compressor |
|--------------------------------------------|--------------------------------------------|
| 90 (3.2) | 90 (3.2) |
| 50 (1.8) | 110 (3.9) |

- (b) When oil contains chips or foreign material; After air conditioner system has been flushed with refrigerant, replace receiver drier. Then install new compressor. [200 mL (7.0 Imp fl oz) of oil is charged in compressor service parts.]

COMPRESSOR — Precautions

- Plug all openings to prevent moisture and foreign matter from entering.
- Do not leave compressor on its side or upside down for more than 10 minutes.
- When replacing or repairing compressor, check compressor oil level in system.
- When replacing with a new compressor, drain specified oil from new compressor. Refer to COMPRESSOR OIL.
- Be sure there is no oil or dirt on frictional surface of clutch disc and pulley.
- When replacing compressor clutch, be careful not to scratch shaft or bend pulley.
- When replacing compressor clutch assembly, do not forget BREAK-IN OPERATION.
- When storing a compressor, be sure to fill it with refrigerant to prevent rust formation. Add refrigerant at the low-pressure side and purge air at the high-pressure side, while rotating shaft by hand.
- When replacing parts, always use new O-rings.

COMPRESSOR — Model NVR 140S (ATSUGI make)

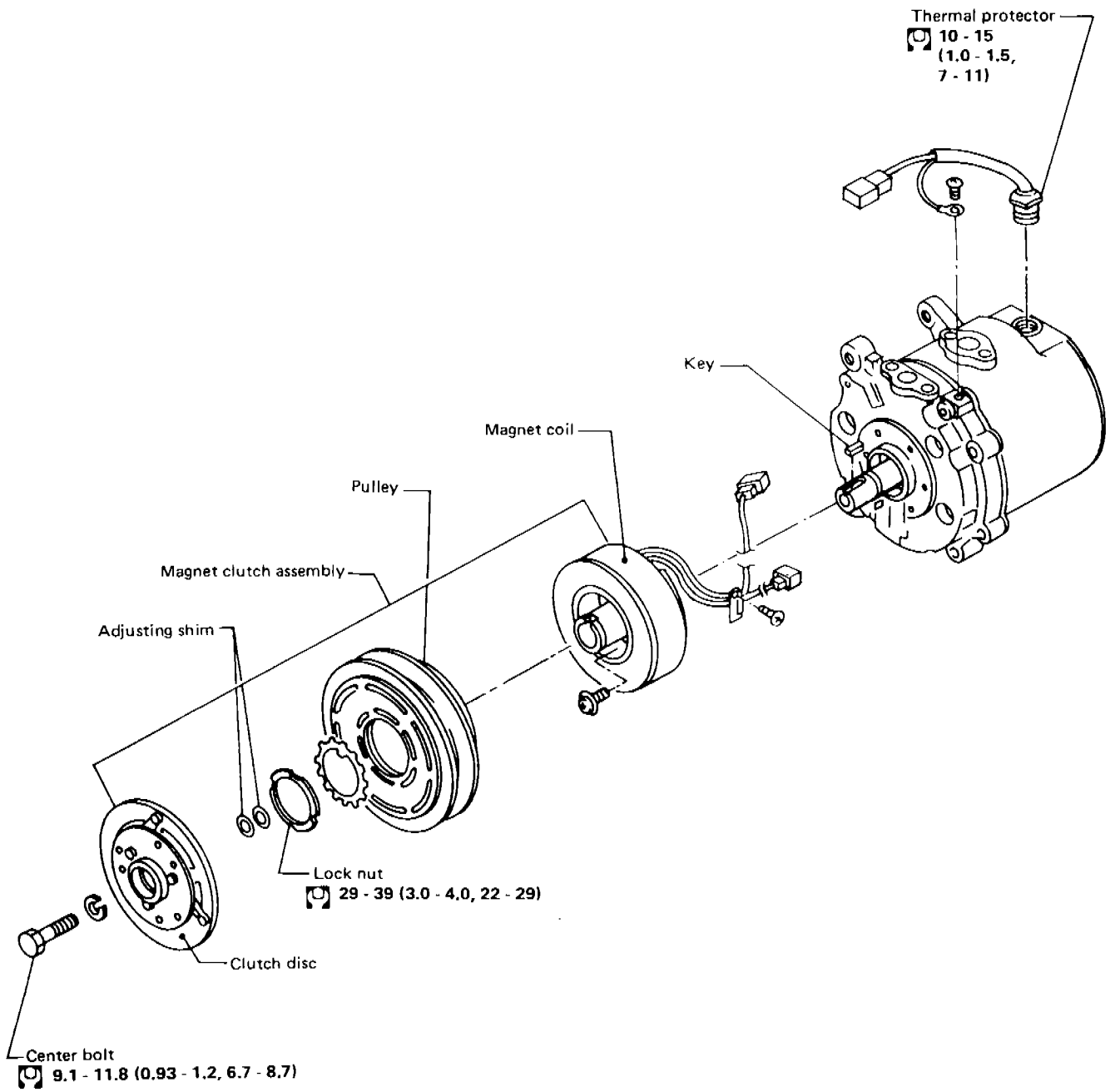

: N·m (kg·m, ft·lb)

RHA283

COMPRESSOR — Model NVR 140S (ATSUGI make)

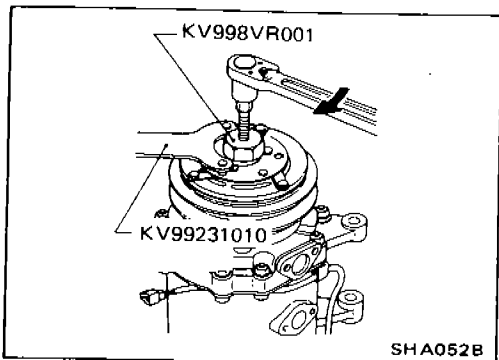

Compressor Clutch REPLACEMENT

- When removing center bolt, hold clutch disc with clutch disc wrench.
- Using clutch disc puller, clutch disc can be removed.

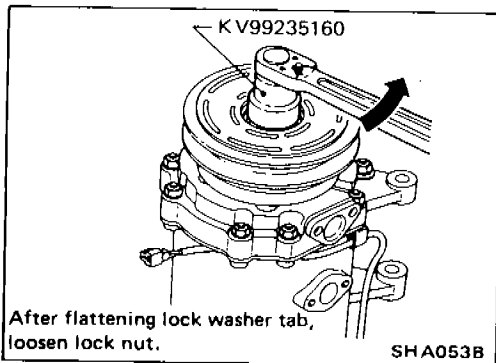

- Bend down pawl of lock washer.
- When removing pulley, remove lock nut with nut wrench.

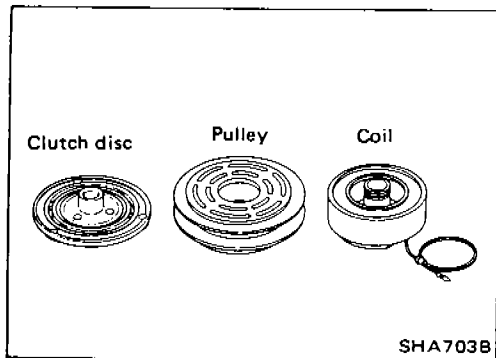

INSPECTION

Clutch disc

If the contact surface shows signs of damage due to excessive heat, the drive plate and pulley should be replaced.

Pulley

Check the appearance of the pulley assembly. If the contact surface of the pulley shows signs of excessive grooving due to slippage, both the pulley and drive plate should be replaced. The contact surfaces of the pulley assembly should be cleaned with a suitable solvent before reinstallation.

Coil

Check coil for loose connection or cracked insulation.

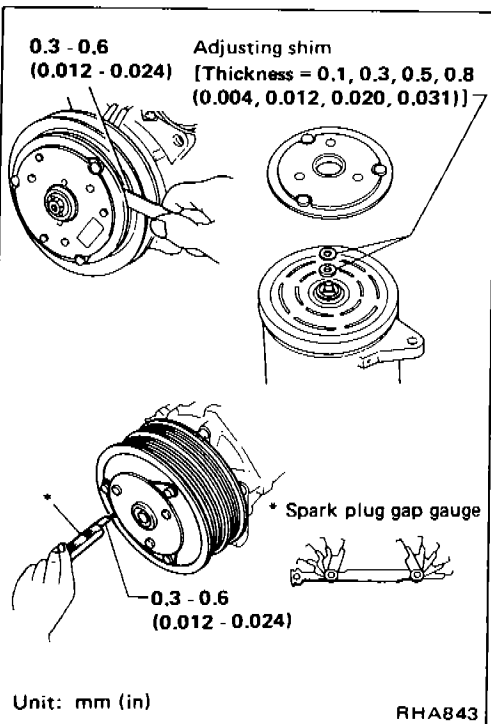

ADJUSTMENT

- When assembling clutch disc, adjust disc-to-pulley clearance with shims.

BREAK-IN OPERATION

When replacing compressor clutch assembly, do not forget break-in operation, accomplished by engaging and disengaging the clutch about thirty times.

Break-in operation raises the level of transmitted torque.

COMPRESSOR — Model NVR 140S (ATSUGI make)

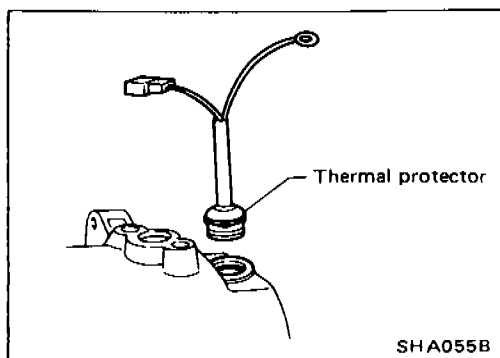

Thermal Protector

- When servicing, do not allow foreign material to get into compressor.
- Check continuity between two terminals.

COMPRESSOR — Model DKV-14C (DIESEL-KIKI make)

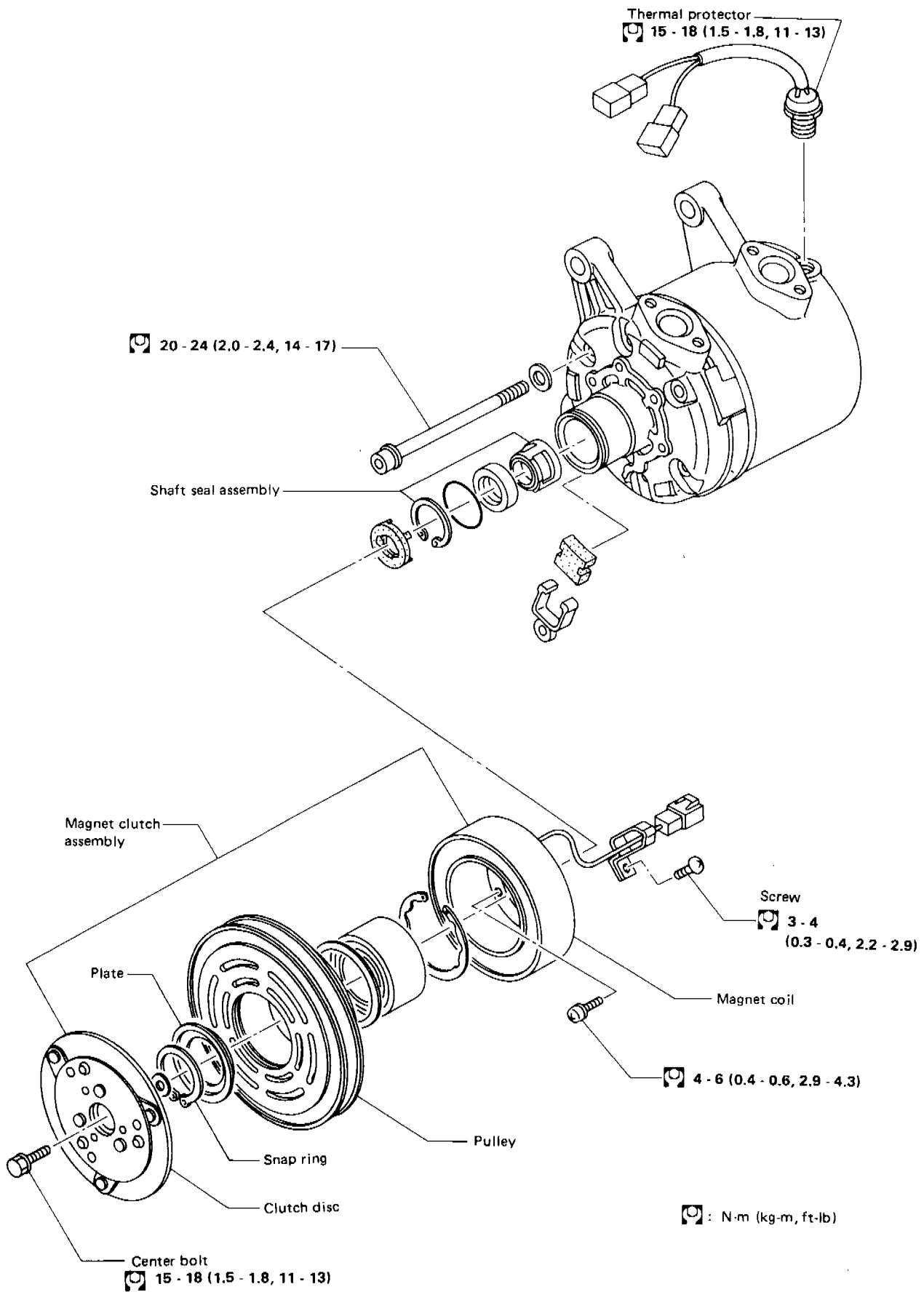

HA-47

RHA402

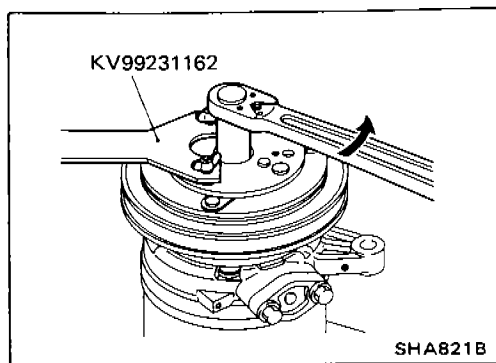

Compressor Clutch REMOVAL

- When removing center bolt, hold clutch disc with clutch disc wrench.

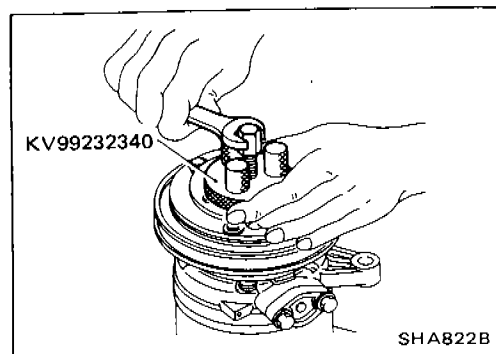

- Using clutch disc puller clutch disc can be removed easily.

INSPECTION

Clutch disc

If the contact surface shows signs of damage due to excessive heat, the clutch disc and pulley should be replaced.

Pulley

Check the appearance of the pulley assembly. If the contact surface of the pulley shows signs of excessive grooving due to slippage, both the pulley and clutch disc should be replaced. The contact surfaces of the pulley assembly should be cleaned with a suitable solvent before reinstallation.

Coil

Check coil for loose connection or cracked insulation.

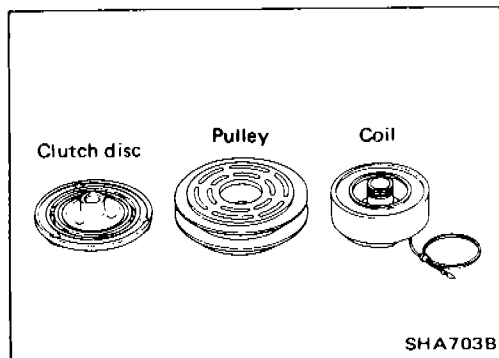

INSTALLATION

- Position coil assembly on compressor body. Be sure that the electrical terminals are reassembled in the original position. Install and tighten coil mounting screws evenly.

COMPRESSOR — Model DKV-14C (DIESEL-KIKI make)

Compressor Clutch (Cont'd)

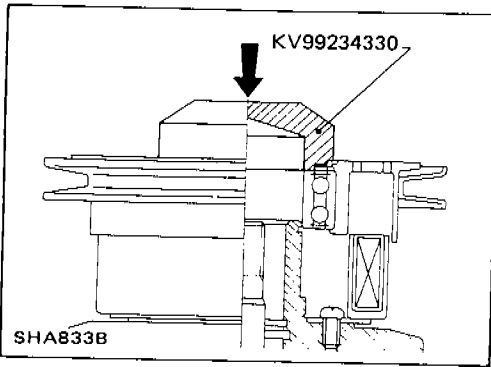

- Press pulley assembly onto the neck of coil assembly using pulley installer.
- Wipe oil thoroughly off the clutch surface.

ADJUSTMENT

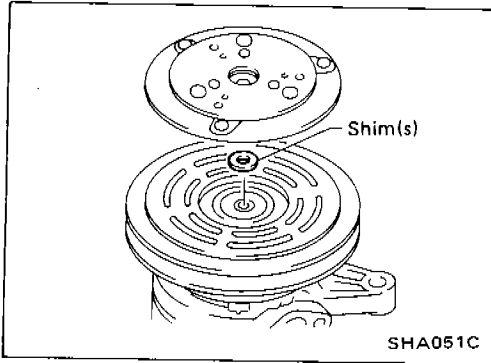

- Select adjusting shim(s) which give(s) the correct clearance between pulley and clutch disc.
- Using a plastic mallet, tape clutch disc in place on drive shaft.
- Do not use excessive force with a plastic mallet or in a press, or internal damages may result.
- Place spring washer and center bolt onto drive shaft. Tighten center bolt to drive clutch wheel onto drive shaft.

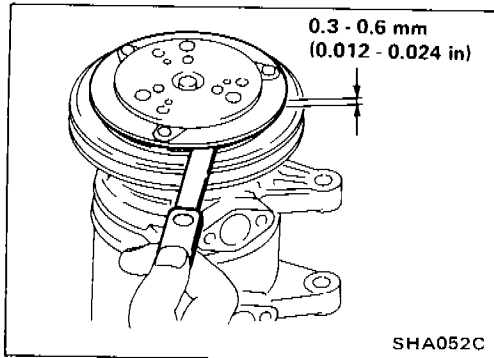

- Check clearance around the entire periphery of clutch disc.
Disc-to-pulley clearance:
0.3 - 0.6 mm (0.012 - 0.024 in)
If the specified clearance is not obtained, replace adjusting spacer and readjust.

BREAK-IN OPERATION

When replacing compressor clutch assembly, do not forget break-in operation, accomplished by engaging and disengaging the clutch about thirty times.

Break-in operation raises the level of transmitted torque.

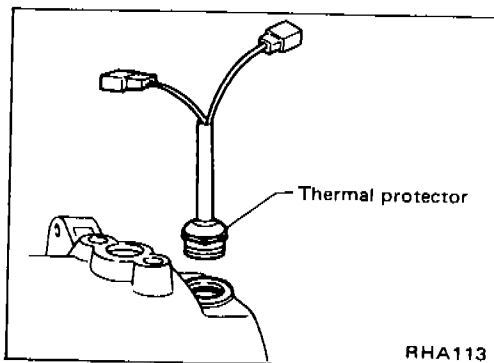

Thermal Protector

INSPECTION

- When servicing, do not allow foreign material to get into compressor.
- Check continuity between two terminals.

A/C COMPONENT LAYOUT

Passenger compartment

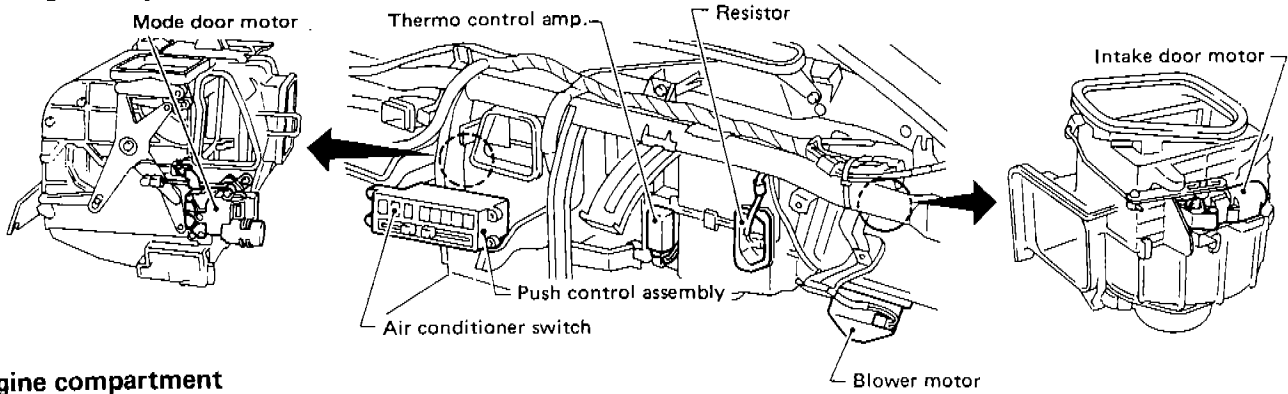

Engine compartment

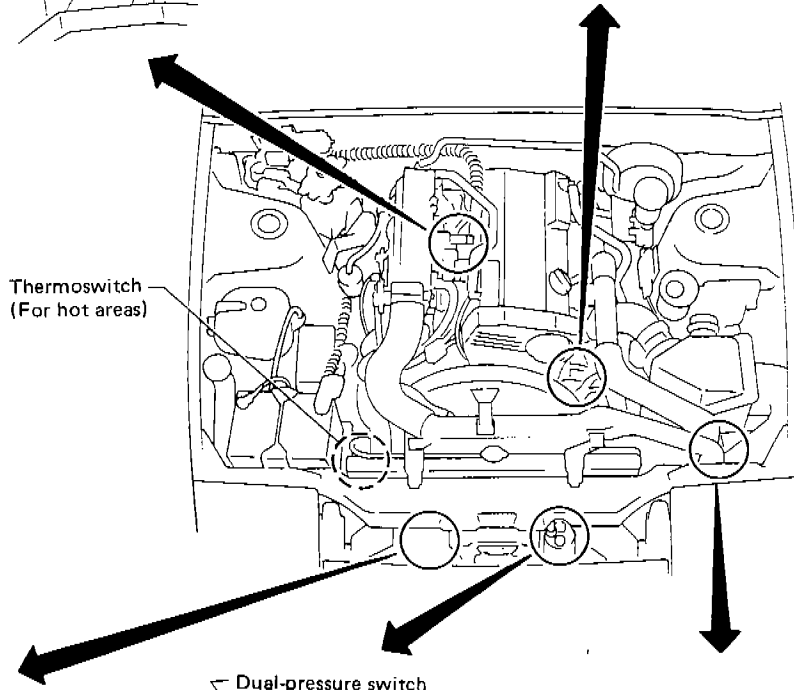
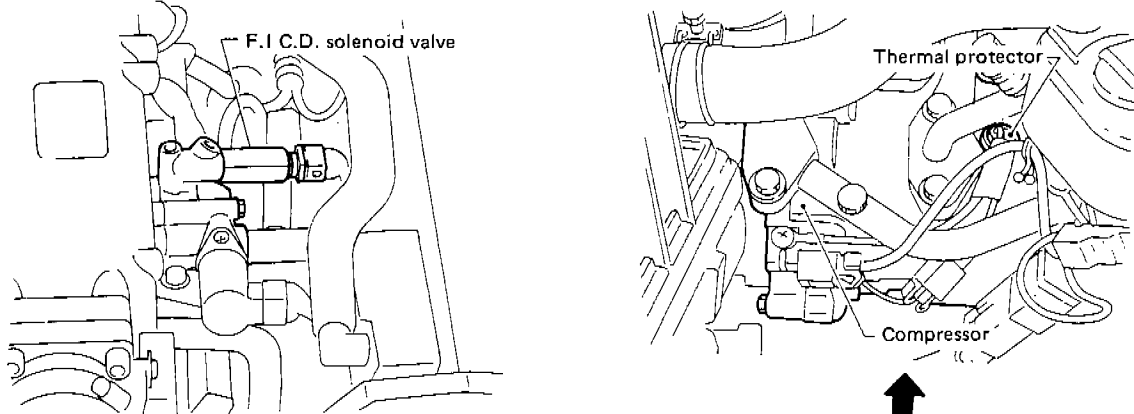

For hot areas

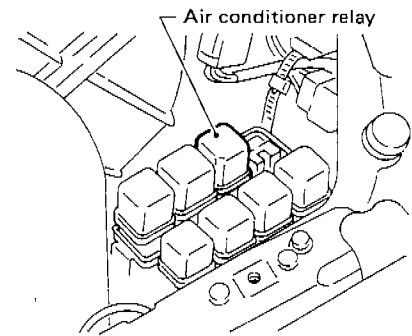
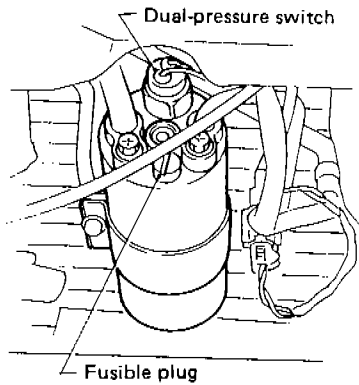
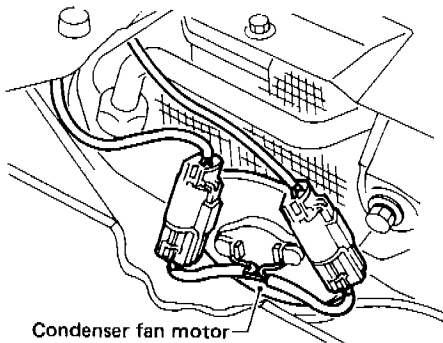

This illustration is for L.H. drive models.
For R.H. drive models, it is basically same.

HA-50

RHA640A

A/C COMPONENT LAYOUT

NOTE

HA-51

A/C ELECTRICAL CIRCUIT

Wiring Diagram

L.H.D. MODEL

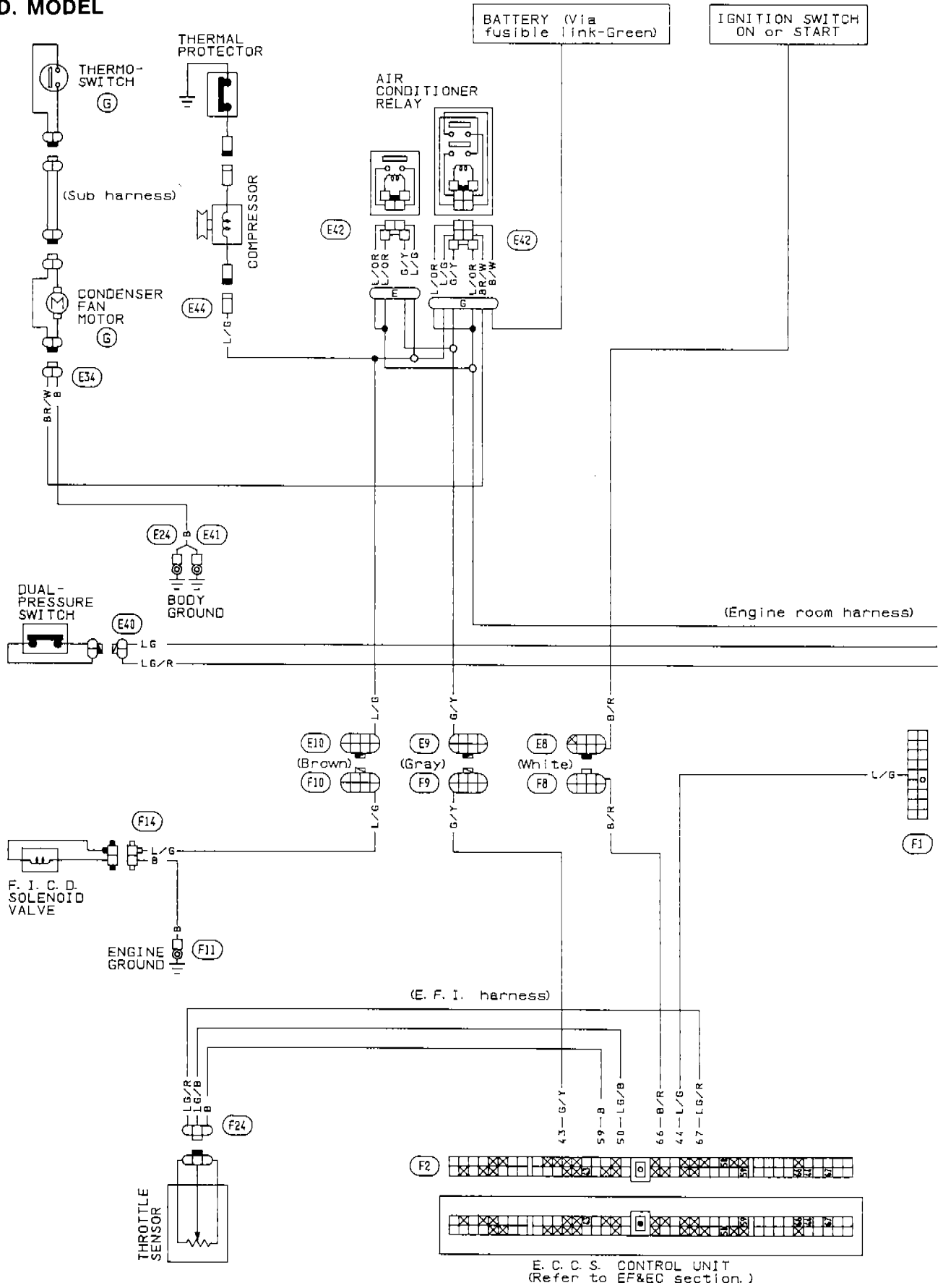

A/C ELECTRICAL CIRCUIT

Wiring Diagram (Cont'd)

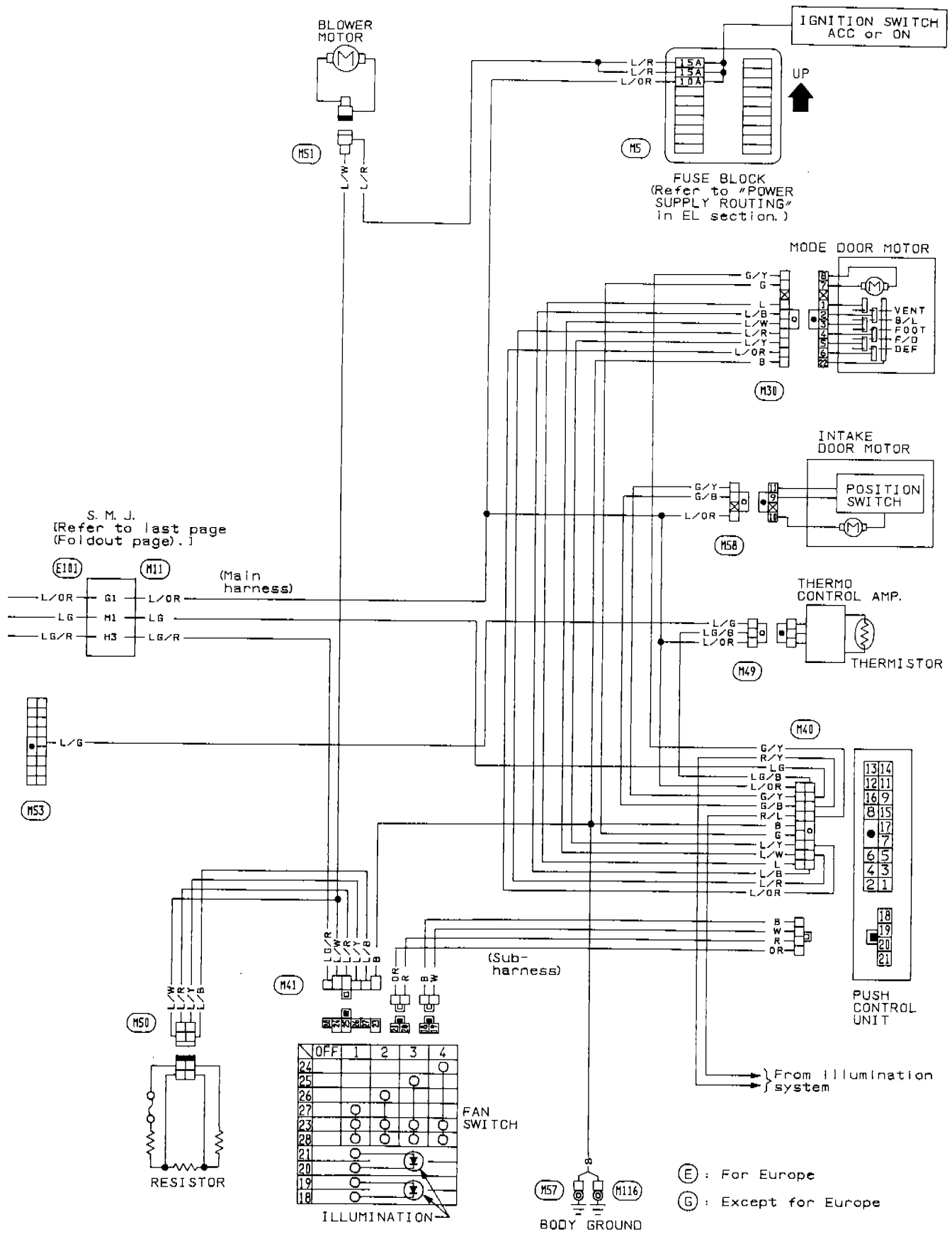

A/C ELECTRICAL CIRCUIT

Wiring Diagram (Cont'd)

R.H.D. MODEL

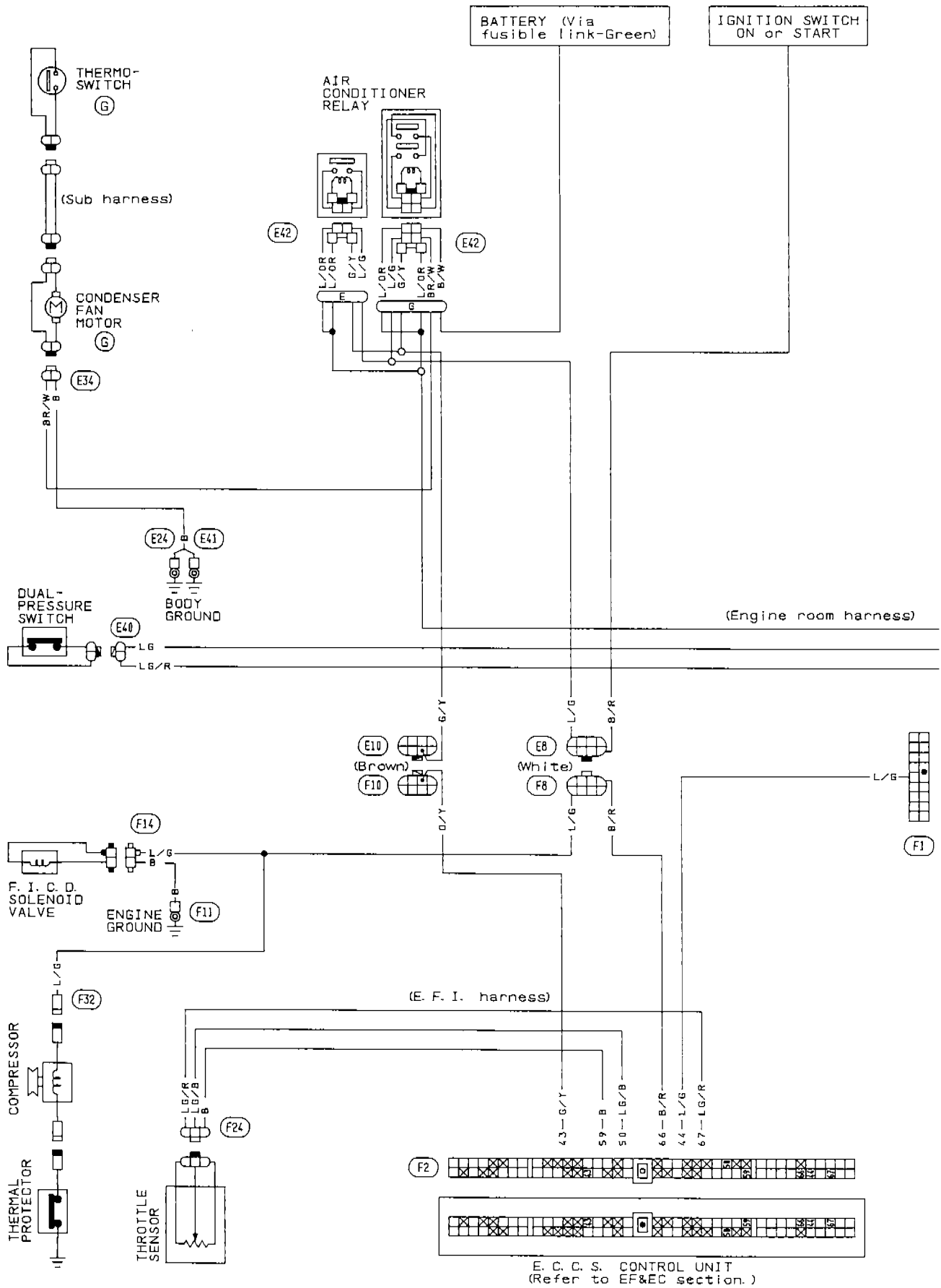

HA-54

A/C ELECTRICAL CIRCUIT

Wiring Diagram (Cont'd)

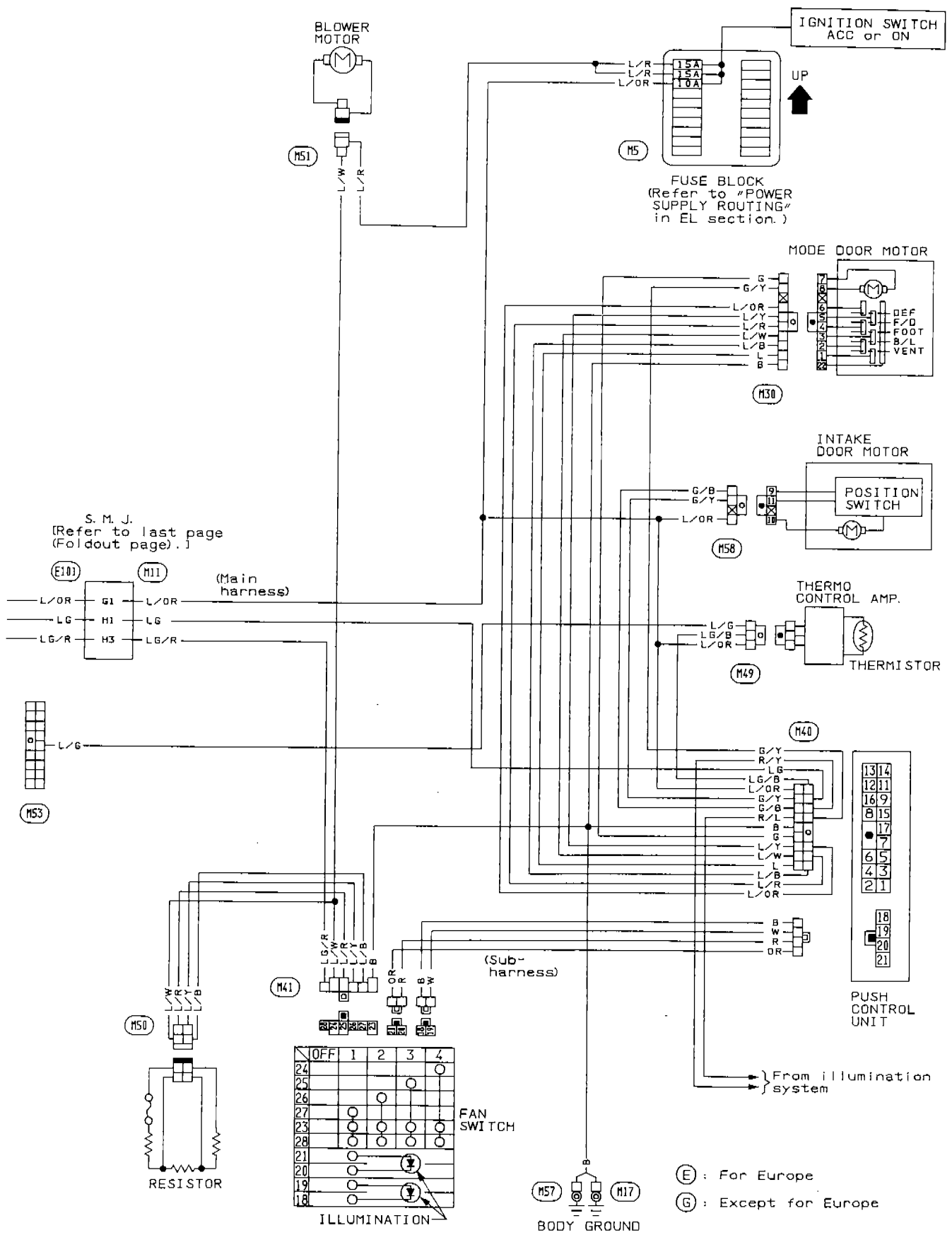

S. M. J.
[Refer to last page
(Foldout page).]

TROUBLE DIAGNOSES

Contents

| | |
|-------------------------------------------------------------------------------------------------------------------------|-------|
| How to Perform Trouble Diagnoses for Quick and Accurate Repair | HA-57 |
| Symptom Chart | HA-58 |
| Preliminary Check | HA-60 |
| PRELIMINARY CHECK 1: FOR L.H.D. MODEL ONLY (Intake door is not set at "FRESH" in DEF or F/D mode.) | HA-60 |
| PRELIMINARY CHECK 2 (A/C does not blow cold air.) | HA-61 |
| PRELIMINARY CHECK 3: FOR L.H.D. MODEL ONLY (Magnet clutch does not operate in DEF mode.) | HA-62 |
| PRELIMINARY CHECK 4 (Air outlet does not change.) | HA-63 |
| PRELIMINARY CHECK 5 (Noise) | HA-64 |
| Main Power Supply and Ground Circuit Check | HA-65 |
| Harness Layout for A/C System | HA-67 |
| Circuit Diagram for Quick Pinpoint Check | HA-68 |
| Diagnostic Procedure 1 (SYMPTOM: Blower motor does not rotate.) | HA-70 |
| Diagnostic Procedure 2 (SYMPTOM: Air outlet does not change.) | HA-72 |
| Diagnostic Procedure 3 (SYMPTOM: Intake door does not change.) | HA-74 |
| Diagnostic Procedure 4 (SYMPTOM: Magnet clutch does not operate with A/C switch and fan switch are ON.) | HA-75 |
| Diagnostic Procedure 5 (SYMPTOM: Illumination or indicators of push control unit do not come on.) | HA-79 |
| Electrical Components Inspection | HA-83 |

TROUBLE DIAGNOSES

How to Perform Trouble Diagnoses for Quick and Accurate Repair

WORK FLOW

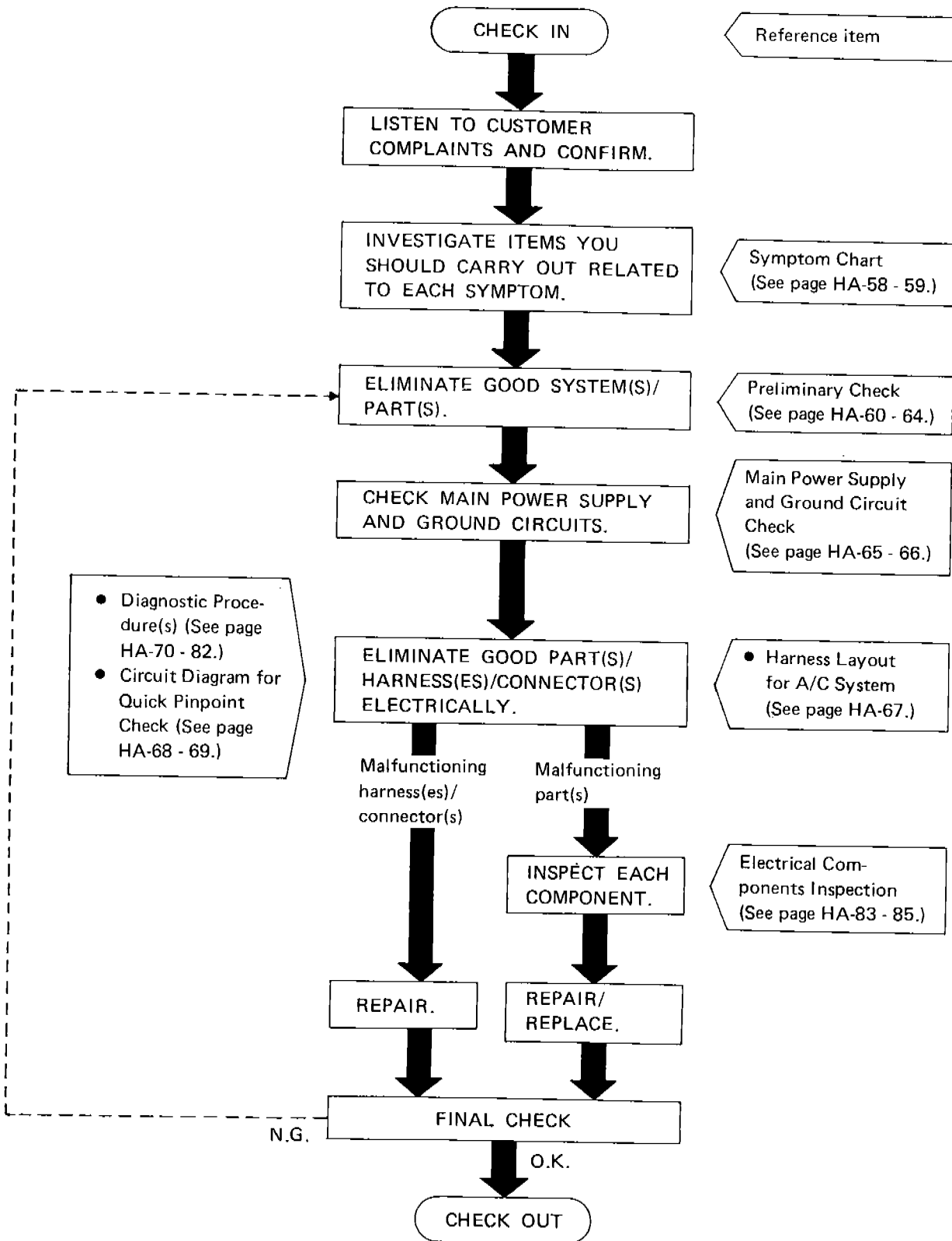

TROUBLE DIAGNOSES

Symptom Chart

DIAGNOSTIC TABLE

| PROCEDURE | Preliminary Check | | | | | Diagnostic Procedure | | | | | Main Power Supply and Ground Circuit Check | | | |
|---------------------------------------------------------------------------|-------------------|-------|-------|-------|-------|----------------------|------------|-------|------------|-------|--------------------------------------------|-------|-------|-------|
| | HA-60 | HA-61 | HA-62 | HA-63 | HA-64 | HA-70 - 71 | HA-72 - 73 | HA-74 | HA-75 - 78 | HA-79 | HA-65 | HA-65 | HA-66 | HA-65 |
| REFERENCE PAGE | | | | | | | | | | | | | | |
| SYMPTOM | | | | | | | | | | | | | | |
| A/C does not blow cold air. | | ① | | | | ○ | | | ○ | | ○ | ○ | | ○ |
| Blower motor does not rotate. | | ① | | | | ② | | | | | ○ | | | |
| Air outlet does not change. | | | | ① | | ② | | | | | | ○ | ○ | |
| Intake door does not change. | | | | | | | | ① | | | | ○ | ○ | |
| Intake door is not set at "FRESH" in DEF or F/D mode. (L.H.D. model only) | ① | | | | | | | ○ | | | | ○ | ○ | |
| Magnet clutch does not operate with A/C switch and fan switch are ON. | | ① | | | | | | | ② | | | ○ | | ○ |
| Magnet clutch does not operate in DEF mode. (L.H.D. model only) | | ① | ② | | | | | | ○ | | | ○ | | ○ |
| Illumination or indicators of push control unit do not come on. | | | | | | | | | | ① | | ○ | | |
| Noise | | | | | ① | | | | | | | | | |

①, ② : The number means checking order.

○ : As for checking order, refer to each flow chart. (It depends on malfunctioning portion.)

TROUBLE DIAGNOSES

Preliminary Check

PRELIMINARY CHECK 1: FOR L.H.D. MODEL ONLY

Intake door is set at "FRESH" in DEF or F/D mode.

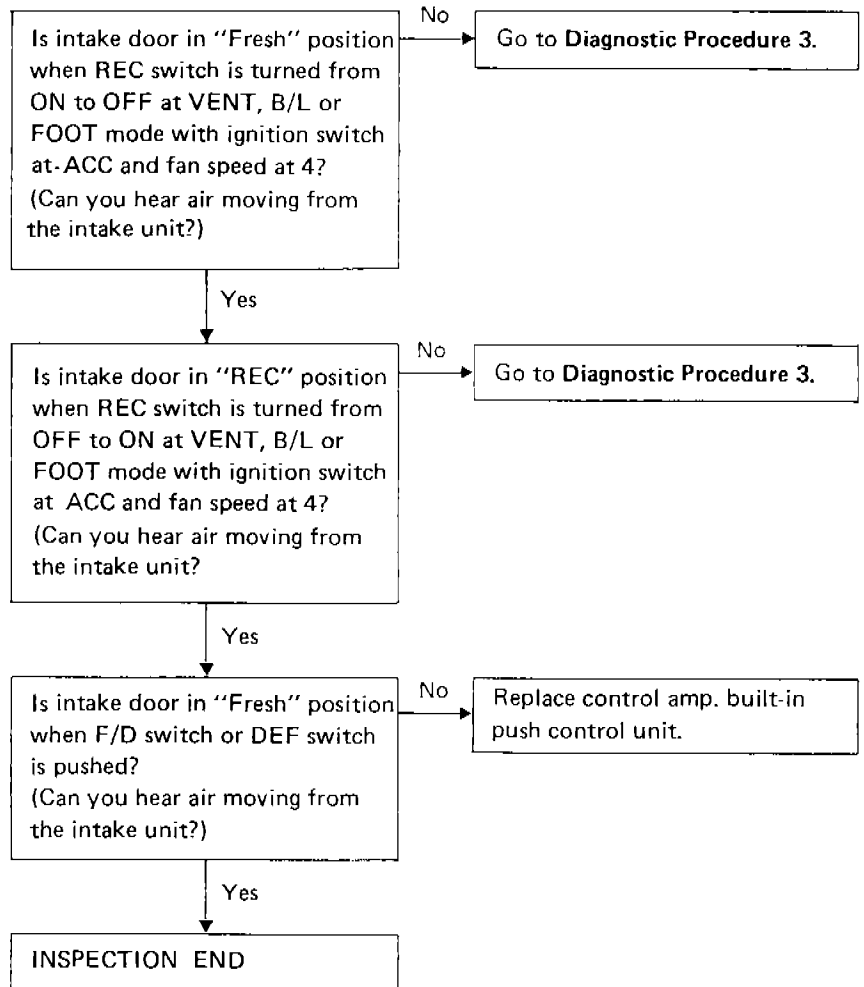

TROUBLE DIAGNOSES

Preliminary Check (Cont'd)

PRELIMINARY CHECK 2

A/C does not blow cold air.

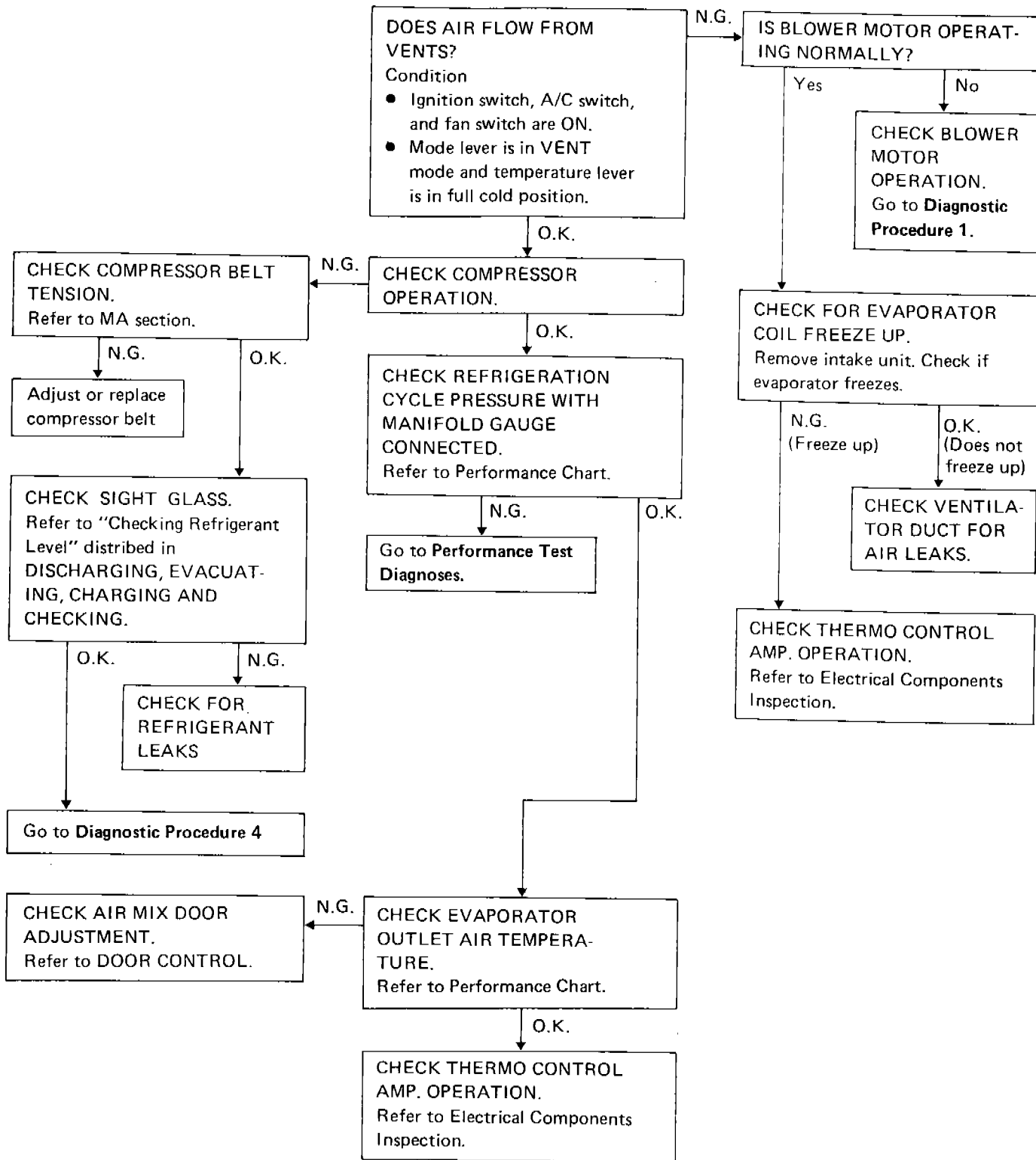

TROUBLE DIAGNOSES

Preliminary Check (Cont'd)

PRELIMINARY CHECK 3: FOR L.H.D. MODEL ONLY

Magnet clutch does not operate in DEF mode.

- Perform PRELIMINARY CHECK 2 before referring to the following flow chart.

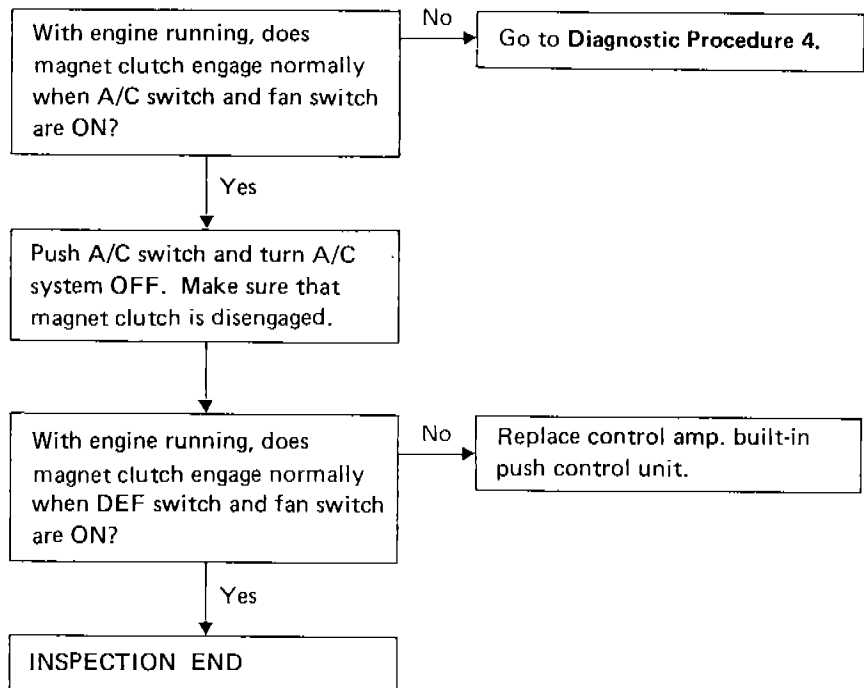

TROUBLE DIAGNOSES

Preliminary Check (Cont'd)

PRELIMINARY CHECK 4

Air outlet does not change.

DOES AIR COME OUT FROM EACH DUCT NORMALLY WHEN EACH MODE SWITCH IS PUSHED WITH IGNITION SWITCH AT ACC?

No → Go to Diagnostic Procedure 2.

| Switch | | Indicator illuminates | | | | | Air outlet | |
|--------|--|-----------------------|---|---|---|---|-------------------|------------------|
| | | | | | | | Except for Europe | For Europe |
| Mode | | ○ | | | | | VENT | VENT |
| | | | ○ | | | | FOOT & VENT | FOOT & VENT |
| | | | | ○ | | | FOOT | FOOT, DEF & VENT |
| | | | | | ○ | | FOOT & DEF | FOOT, DEF & VENT |
| | | | | | | ○ | DEF | DEF & VENT |

Air distribution ratios

Except for Europe

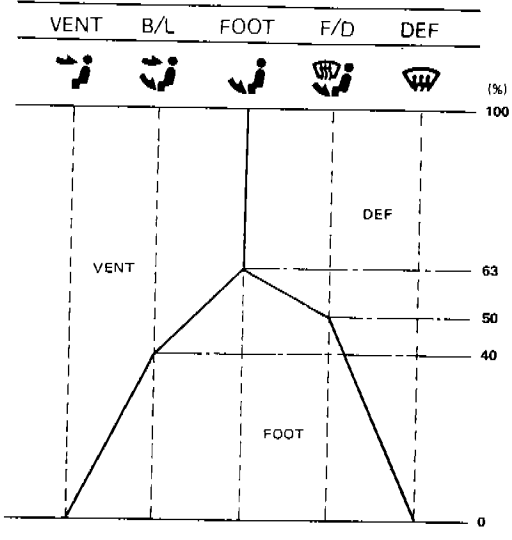

For Europe

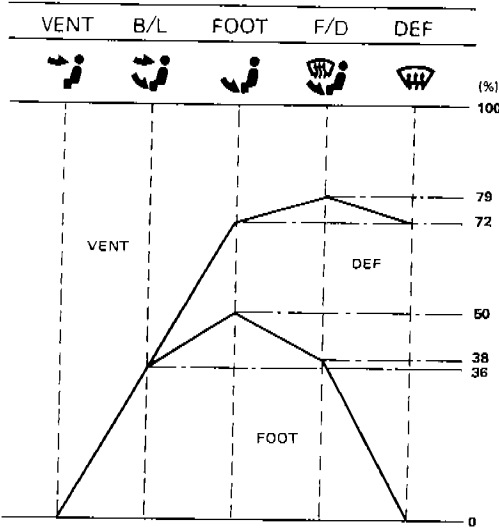

Yes

INSPECTION END

TROUBLE DIAGNOSES

Preliminary Check (Cont'd)

PRELIMINARY CHECK 5

Noise

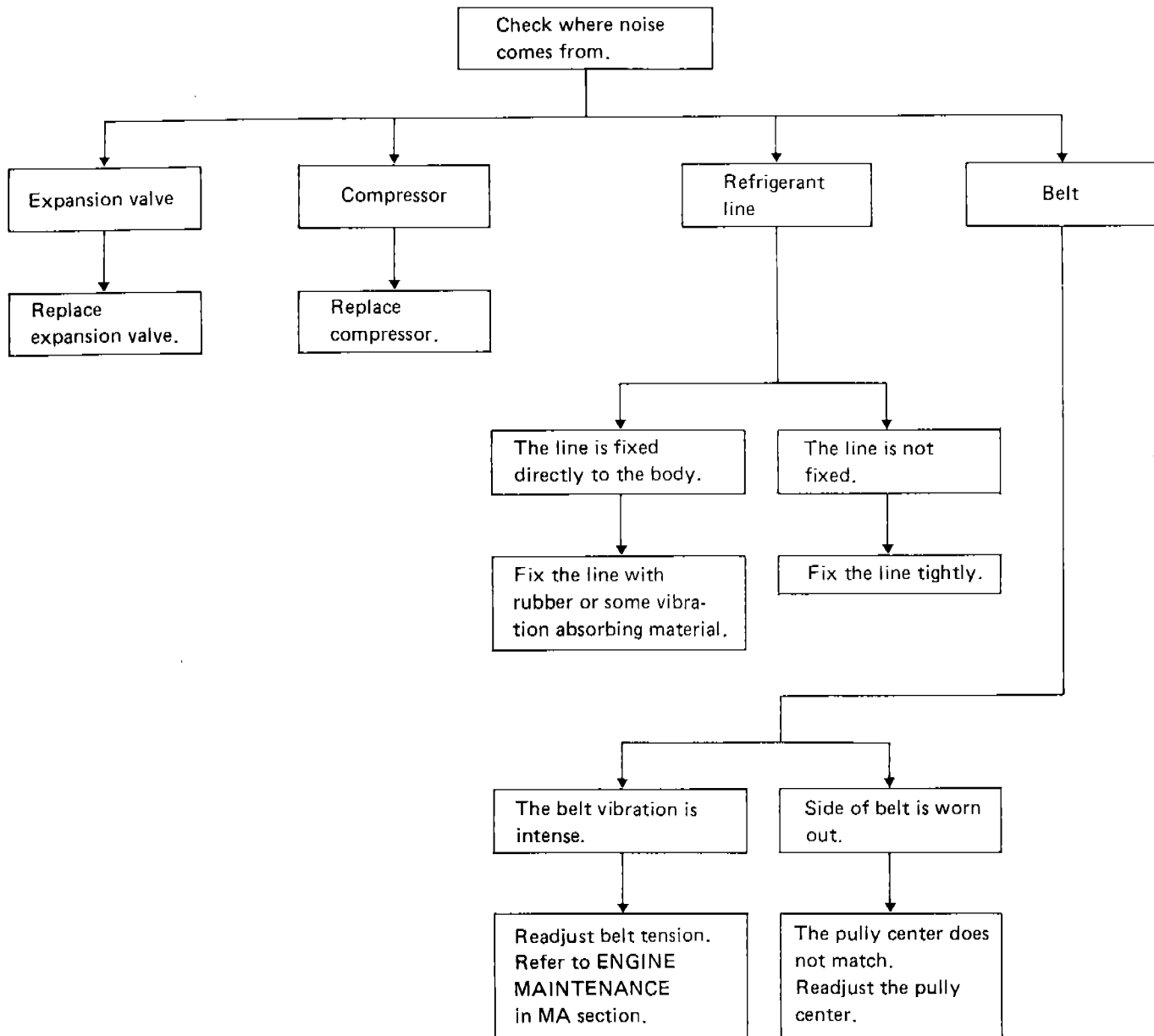

TROUBLE DIAGNOSES

Main Power Supply and Ground Circuit Check POWER SUPPLY CIRCUIT CHECK FOR A/C SYSTEM

Check power supply circuit for air conditioning system.
Refer to "POWER SUPPLY ROUTING" in EL section and A/C ELECTRICAL CIRCUIT.

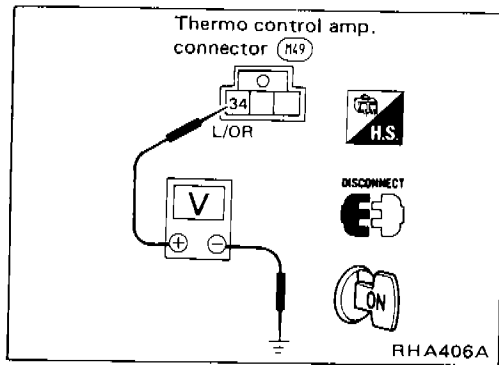

THERMO CONTROL AMP. CHECK

Check power supply circuit for thermo control amp. with ignition switch ON.

1. Disconnect thermo control amp. harness connector.
2. Connect voltmeter from harness side.
3. Measure voltage across terminal No. ③④ and body ground.

| Voltmeter terminal | | Voltage |
|--------------------|-------------|-------------|
| ⊕ | ⊖ | |
| ③④ | Body ground | Approx. 12V |

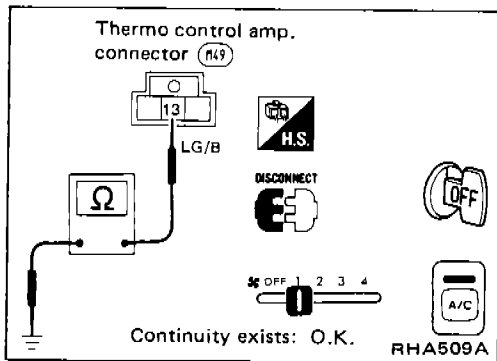

Check body ground circuit for thermo control amp. with ignition switch OFF, A/C switch ON and fan switch ON.

1. Disconnect thermo control amp. harness connector.
2. Connect ohmmeter from harness side.
3. Check for continuity between terminal No. ⑬ and body ground.

| Ohmmeter terminal | | Continuity |
|-------------------|-------------|------------|
| ⊕ | ⊖ | |
| ⑬ | Body ground | Yes |

TROUBLE DIAGNOSES

Main Power Supply and Ground Circuit Check (Cont'd)

PUSH CONTROL UNIT CHECK

Check power supply circuit for push control unit with ignition switch at ACC.

1. Disconnect push control unit harness connector.
2. Connect voltmeter from harness side.
3. Measure voltage across terminal No. ⑭ and body ground.

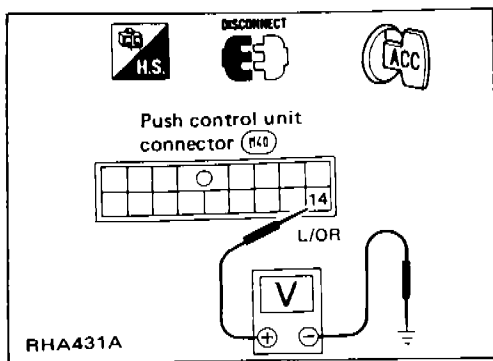

| Voltmeter terminal | | Voltage |
|--------------------|-------------|-------------|
| ⊕ | ⊖ | |
| ⑭ | Body ground | Approx. 12V |

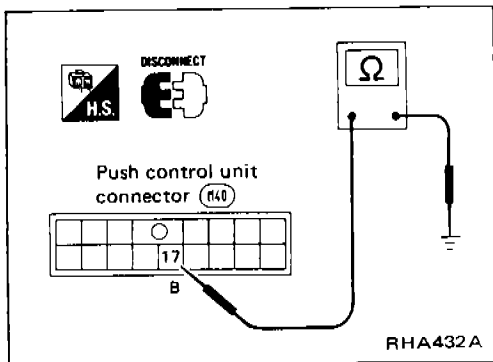

Check body ground circuit for push control unit with ignition switch OFF.

1. Disconnect push control unit harness connector.
2. Connect ohmmeter from harness side.
3. Check for continuity between terminal No. ⑰ and body ground.

TROUBLE DIAGNOSES

Harness Layout for A/C System

Passenger compartment

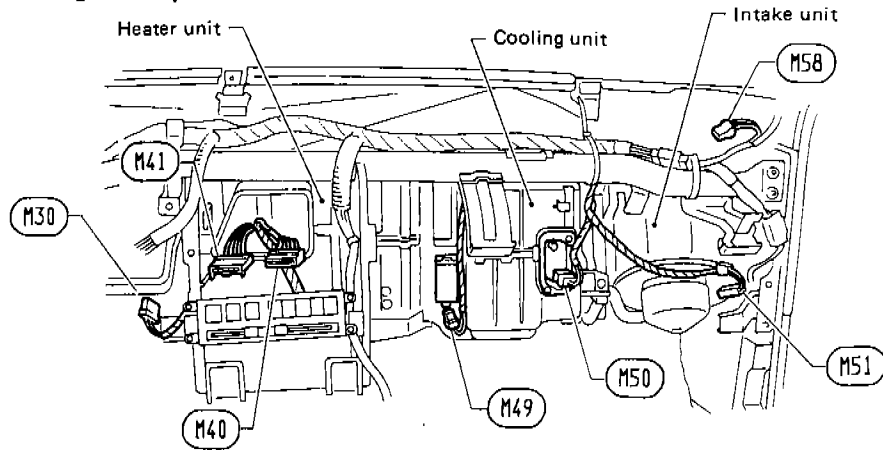

Engine compartment

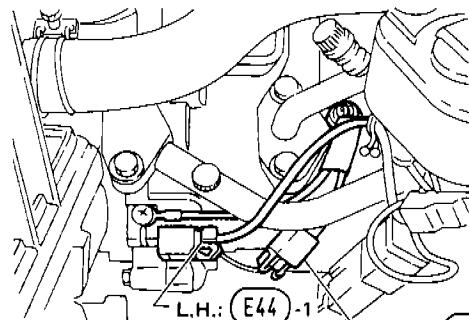

Engine room harness

- (E40) : Dual-pressure switch
- (E42) : A/C relay
- L.H. : (E44)-1 : Compressor (Magnet clutch)
- L.H. : (E44)-2 : Compressor (Thermal protector)

E.F.I. harness

- R.H. : (F32)-1 : Compressor (Magnet clutch)
- R.H. : (F32)-2 : Compressor (Thermal protector)

Main harness

- (M30) : Mode door motor
- (M40) : Push control unit
- (M41) : Fan switch
- (M49) : Thermo control amp.
- (M50) : Resistor
- (M51) : Blower motor
- (M58) : Intake door motor

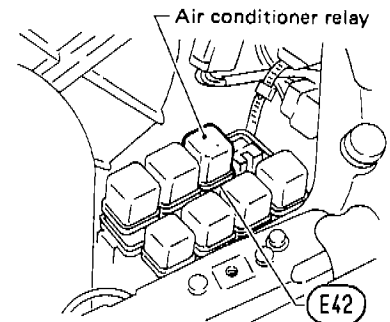
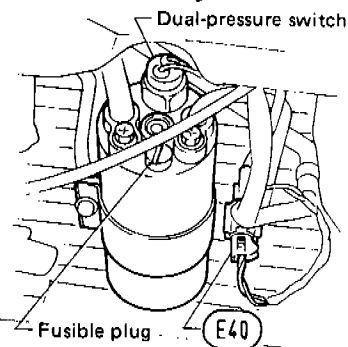
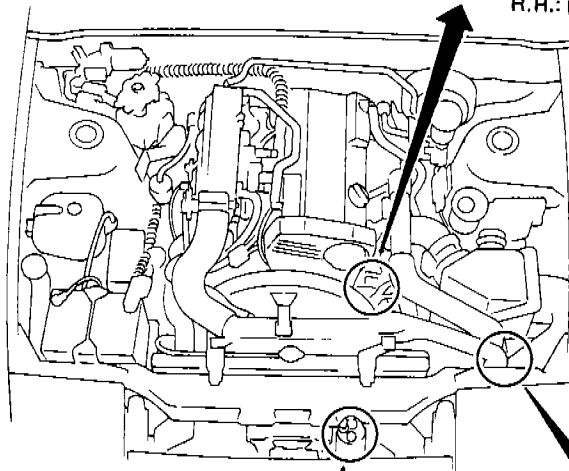

This illustration is for L.H. drive models.
For R.H. drive models, it is basically same.

RHA642A

TROUBLE DIAGNOSES

Circuit Diagram for Quick Pinpoint Check

L.H.D. MODEL

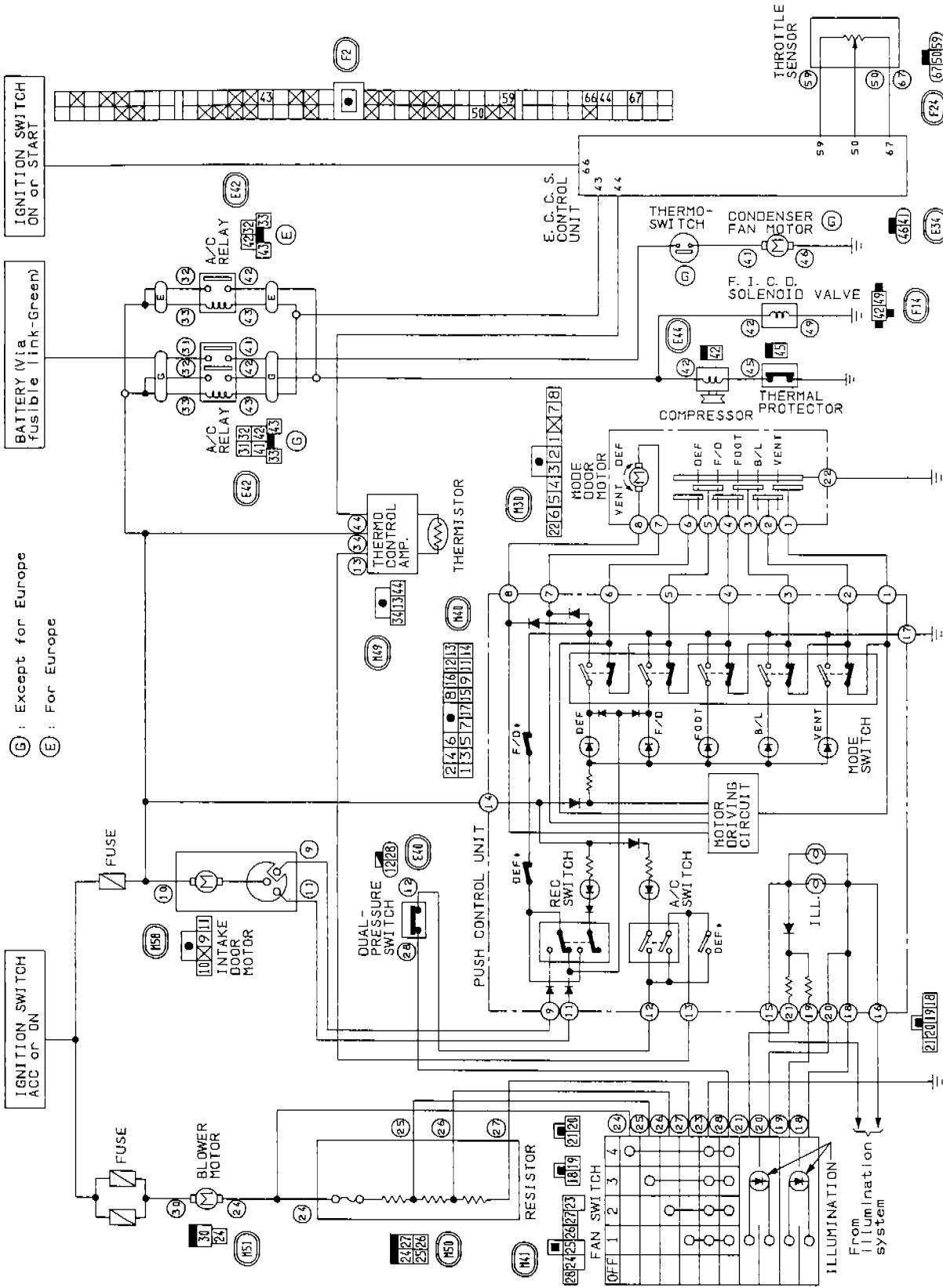

- All connectors shown in this illustration are unit side connectors.
- The unit side connectors with a double circle "⊖" are connected to the harness side connectors shown in the "Harness Layout for A/C System". (See page HA-67.)
- The terminal numbers in the connector coincide with the circuit numbers surrounded by a single circle "○".
- *: These switches are built in push control unit and mechanically linked to corresponding switches.

TROUBLE DIAGNOSES

Circuit Diagram for Quick Pinpoint Check (Cont'd)

R.H.D. MODEL

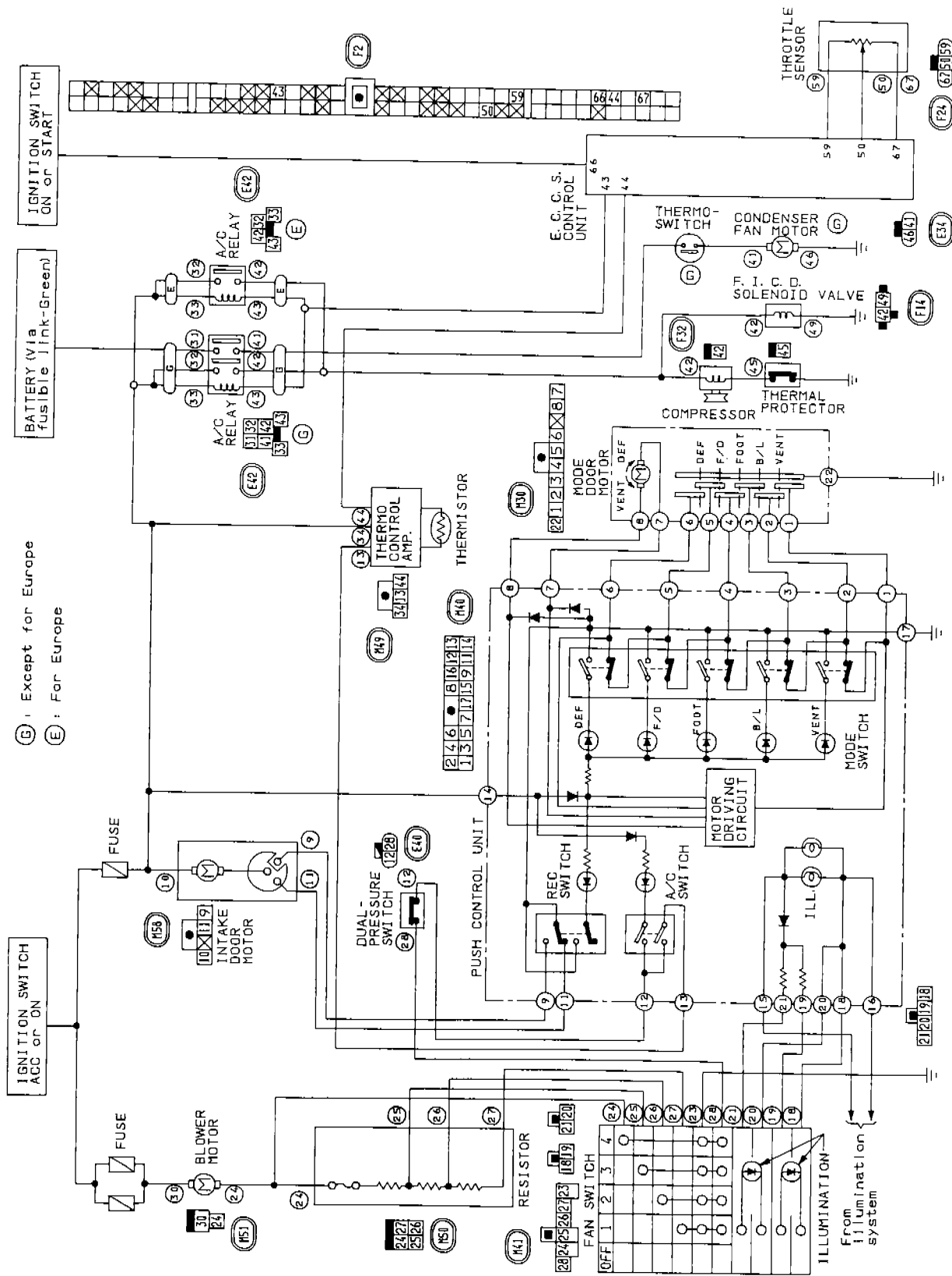

(G) Except for Europe
(E) For Europe

- All connectors shown in this illustration are unit side connectors.
- The unit side connectors with a double circle "⊖" are connected to the harness side connectors shown in the "Harness Layout for A/C System". (See page HA-67.)
- The terminal numbers in the connector coincide with the circuit numbers surrounded by a single circle "○".
- *: These switches are built in push control unit and mechanically linked to corresponding switches.

SHA141C

TROUBLE DIAGNOSES

| | INCIDENT | Flow chart No. |
|---|---------------------------------|----------------|
| 1 | Fan fails to rotate. | 1 |
| 2 | Fan does not rotate at 1-speed. | 2 |
| 3 | Fan does not rotate at 2-speed. | 3 |
| 4 | Fan does not rotate at 3-speed. | 4 |
| 5 | Fan does not rotate at 4-speed. | 5 |

Diagnostic Procedure 1

SYMPTOM: Blower motor does not rotate.

- Perform **PRELIMINARY CHECK 2** before referring to the following flow chart.

Check if blower motor rotates properly at each fan speed. Conduct check as per flow chart at left.

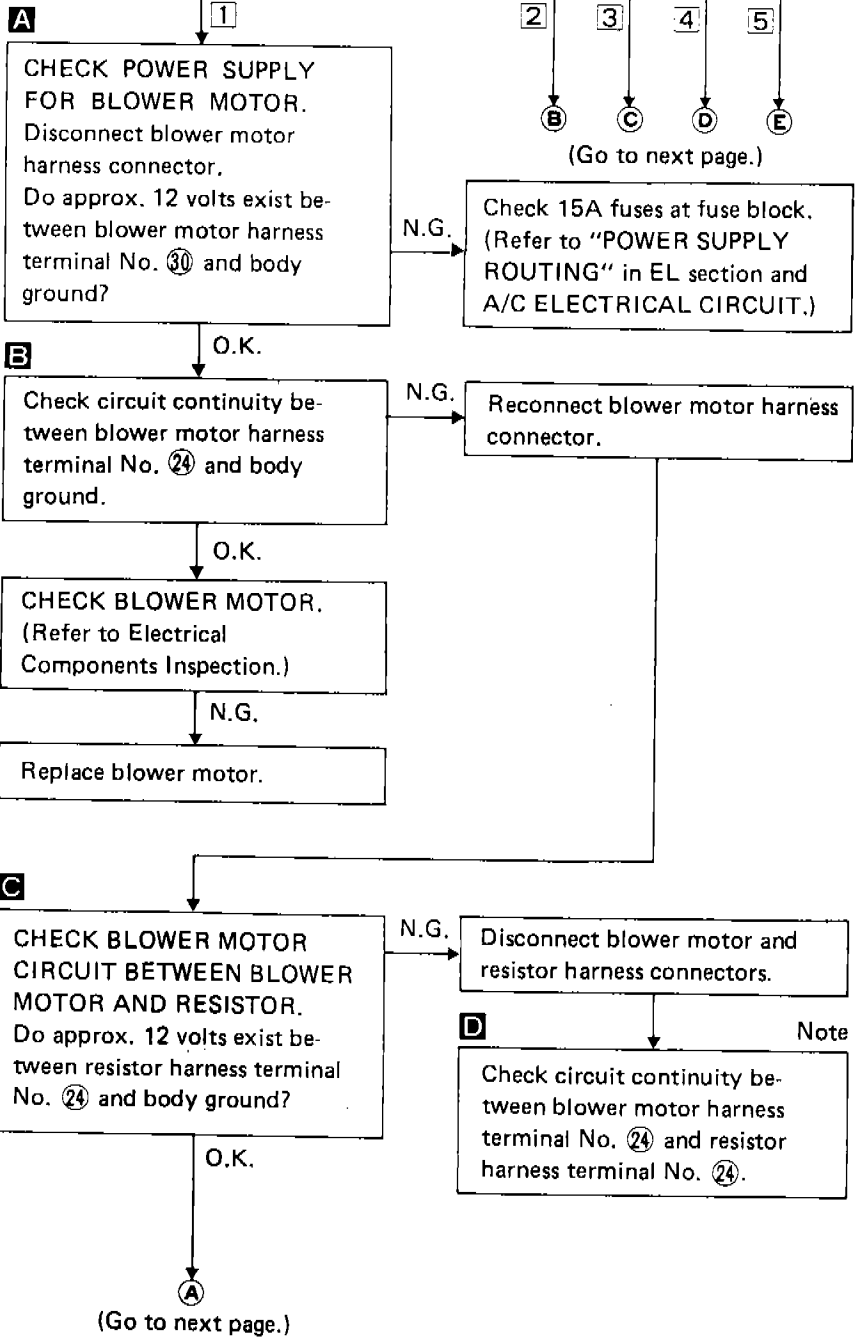
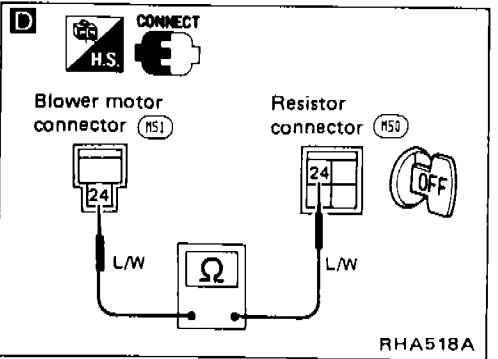
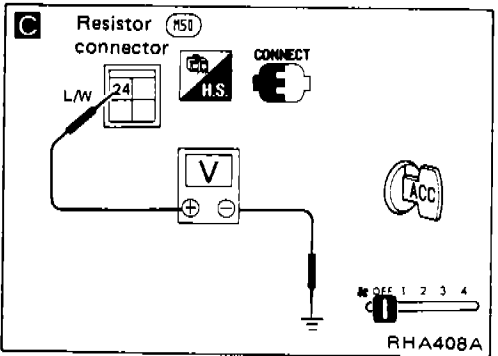
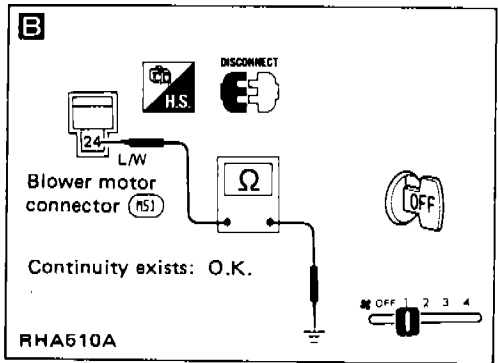
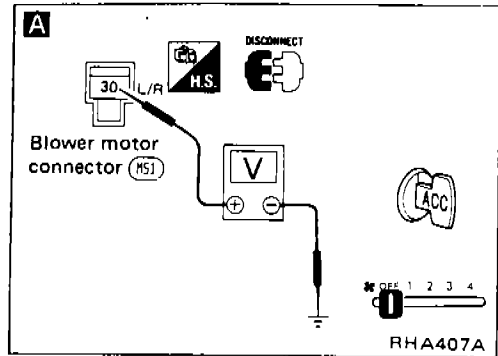

Note:
If the result is N.G. after checking circuit continuity, repair harness or connector.

HA-70

TROUBLE DIAGNOSES

Diagnostic Procedure 1 (Cont'd)

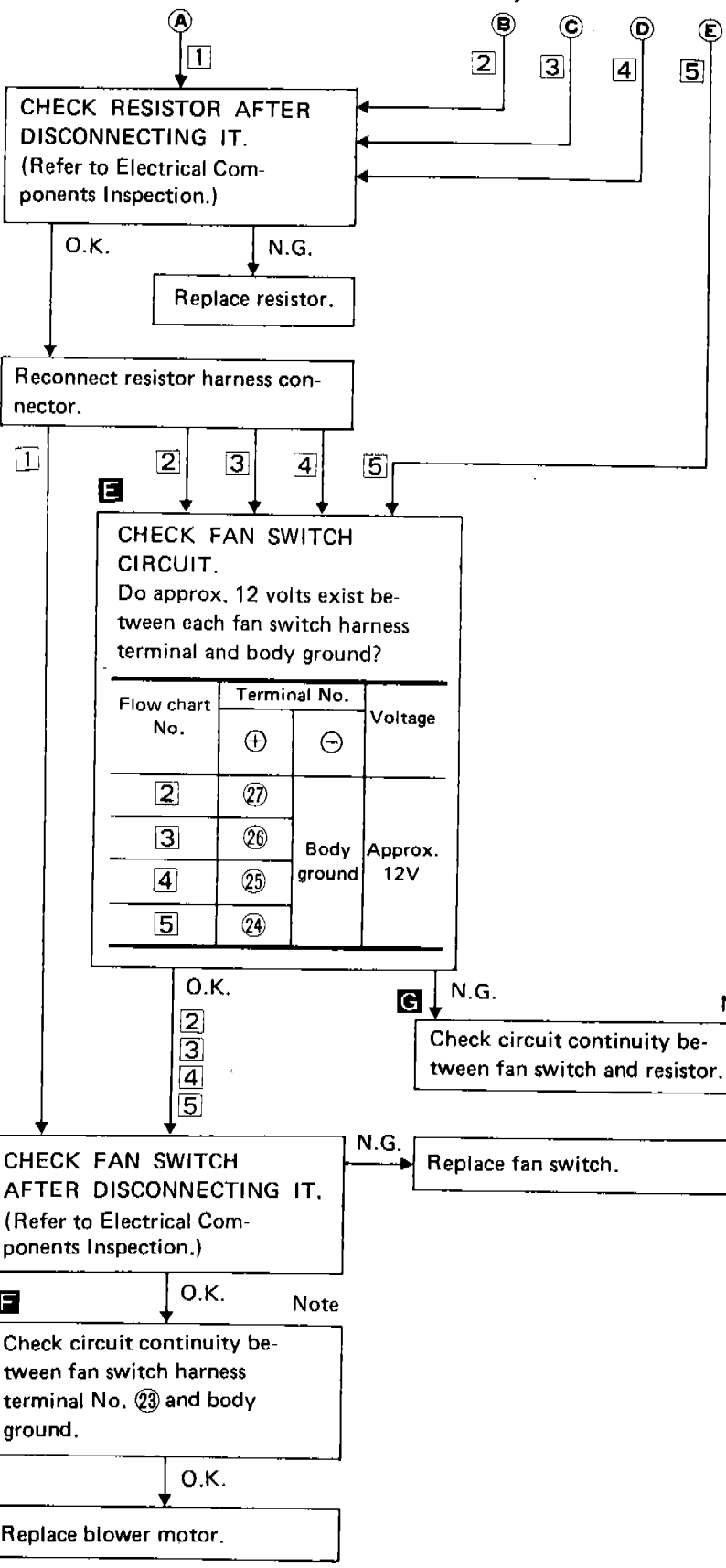
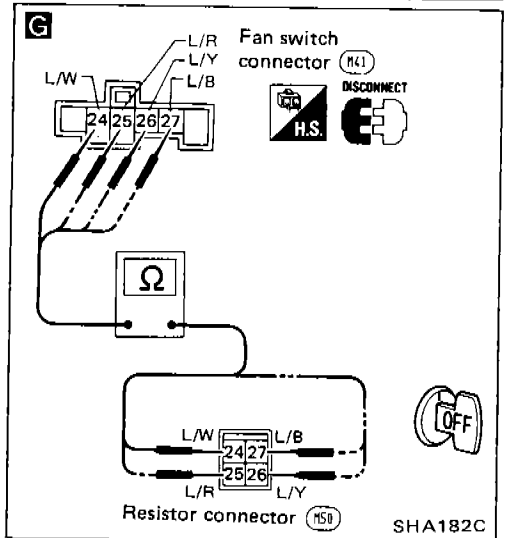
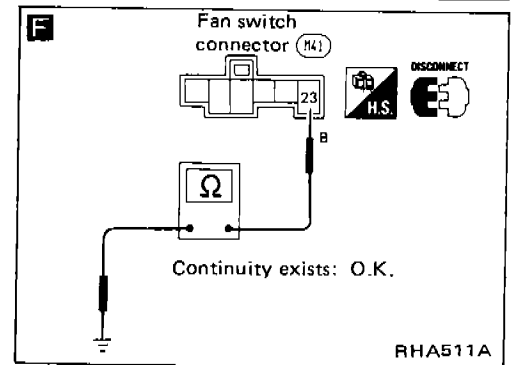
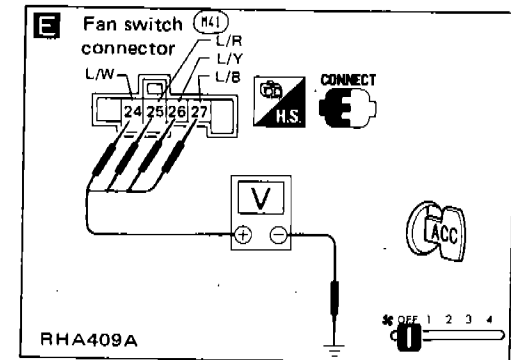

Note:
If the result is N.G. after checking circuit continuity, repair harness or connector.

TROUBLE DIAGNOSES

Diagnostic Procedure 2

SYMPTOM: Air outlet does not change.

- Perform **PRELIMINARY CHECK 4** and **Main Power Supply and Ground Circuit Check** before referring to the following flow chart.

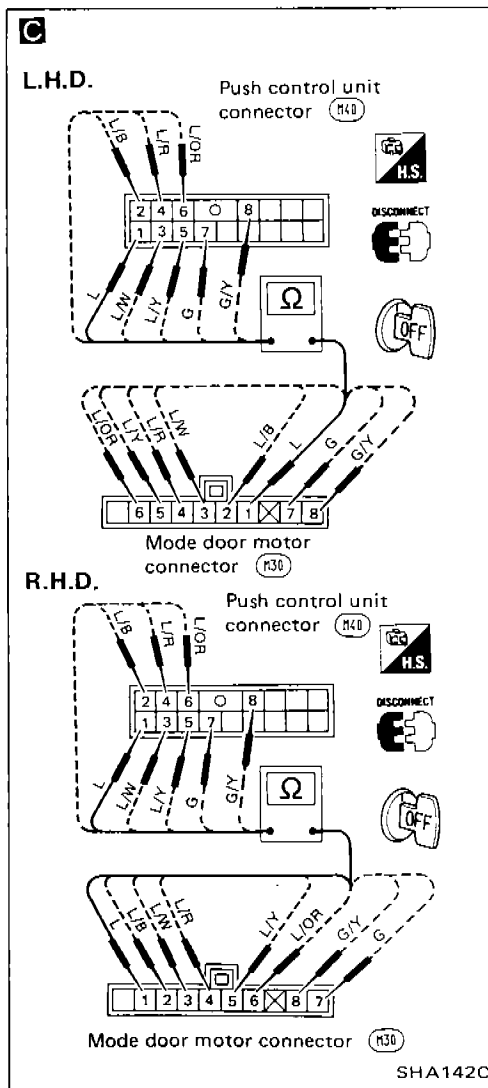
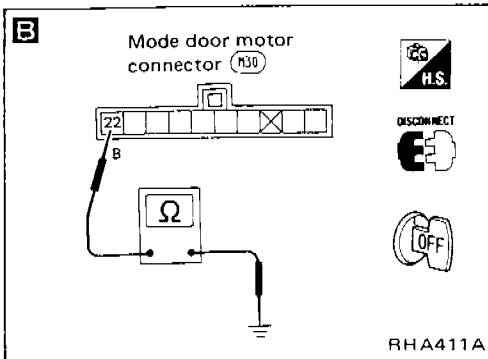
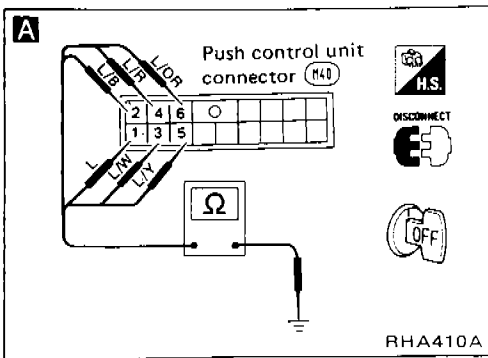

- A**
- CHECK MODE DOOR MOTOR POSITION SWITCH.**
1. Turn VENT switch ON with ignition switch at ACC position.
 2. Turn ignition switch OFF. Disconnect push control unit connector.
 3. Check if continuity exists between terminal No. ① or ② of push control unit harness connector and body ground.
 4. Using above procedures, check for continuity in any other mode, as indicated in chart.

| Mode switch | Terminal No. | | Continuity |
|-------------|--------------|-------------|------------|
| | ⊕ | ⊖ | |
| VENT | ① or ② | Body ground | Yes |
| B/L | ② or ③ | | |
| FOOT | ③ or ④ | | |
| F/D | ④ or ⑤ | | |
| DEF | ⑤ or ⑥ | | |

O.K.

CHECK SIDE LINK.
Refer to **DOOR CONTROL.**

N.G.

Disconnect mode door motor harness connector.

B Note

CHECK BODY GROUND CIRCUIT FOR MODE DOOR MOTOR.
Does continuity exist between mode door motor harness terminal No. ②② and body ground?

O.K. Note

Check circuit continuity between each terminal on push control unit and on mode door motor.

| Terminal No. | Terminal No. | | Continuity |
|-------------------|-----------------|---|------------|
| | ⊕ | ⊖ | |
| Push control unit | Mode door motor | | Yes |
| ① | ① | | |
| ② | ② | | |
| ③ | ③ | | |
| ④ | ④ | | |
| ⑤ | ⑤ | | |
| ⑥ | ⑥ | | |
| ⑦ | ⑦ | | |
| ⑧ | ⑧ | | |

O.K.

(Go to next page.)

Note:
If the result is N.G. after checking circuit continuity, repair harness or connector.

TROUBLE DIAGNOSES

Diagnostic Procedure 2 (Cont'd)

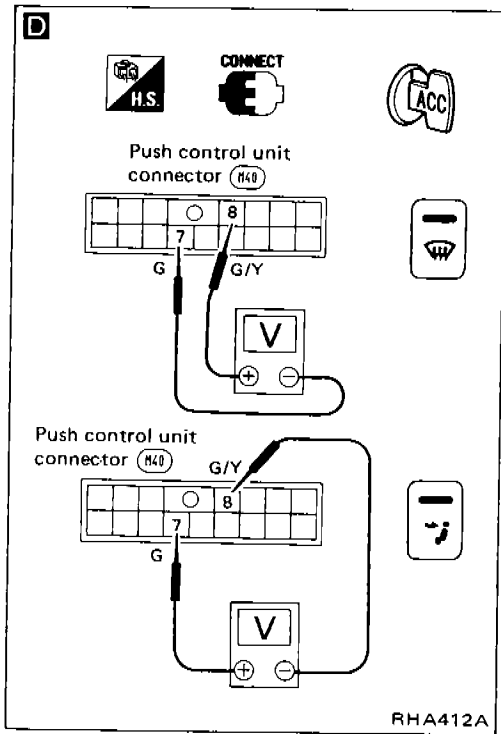

A

Reconnect push control unit and mode door motor harness connectors.

D

CHECK FOR OUTPUT OF PUSH CONTROL UNIT.
Do approx. 12 volts exist between push control unit harness terminal No. ⑦ and ⑧ when mode is switched from "VENT" to "DEF" or when mode is switched from "DEF" to "VENT"?

N.G. → Replace control amp. built-in push control unit.

| Terminal No. | | Mode door motor | |
|--------------|---|---------------------|-----------------------------------------------------------------|
| ⑦ | ⑧ | Mode door operation | Direction of linkage rotation |
| ⊖ | ⊖ | Stop | Stop |
| ⊖ | ⊕ | VENT → DEF | L.H.D. model: Clockwise R.H.D. model: Counterclockwise |
| ⊕ | ⊖ | DEF → VENT | L.H.D. model: Counterclockwise R.H.D. model: Clockwise |

O.K. → Replace mode door motor.

TROUBLE DIAGNOSES

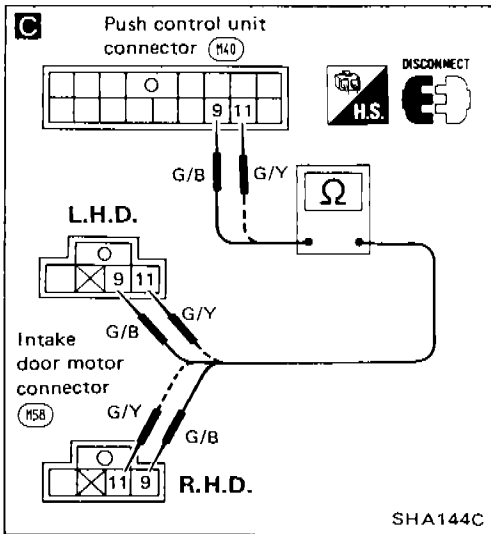
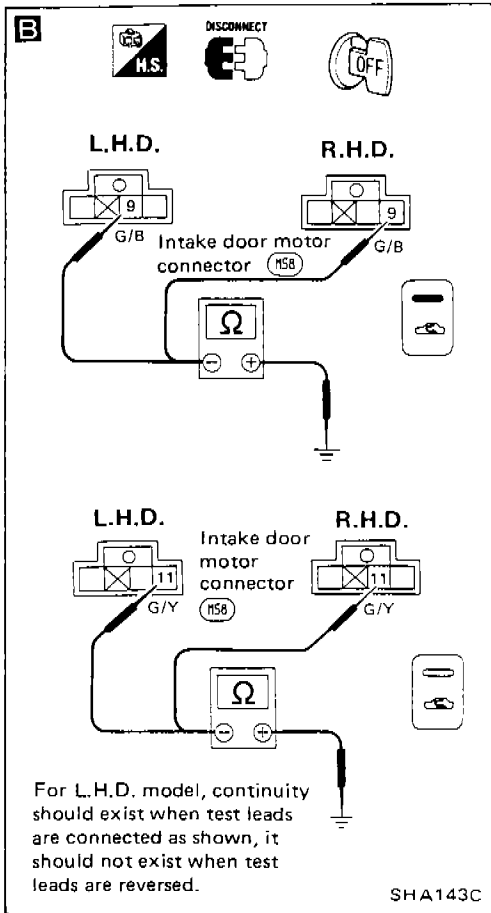
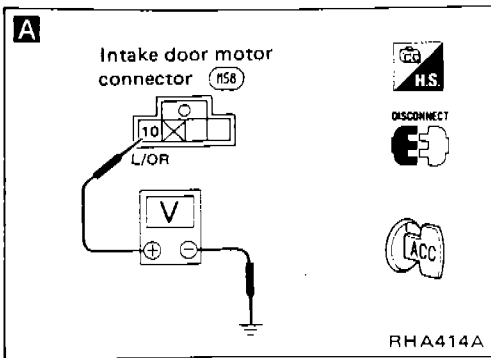

Diagnostic Procedure 3

SYMPTOM: Intake door does not change.

- Perform **PRELIMINARY CHECK 1 (FOR L.H.D. MODEL ONLY)** and Main Power Supply and Ground Circuit Check before referring to the following flow chart.

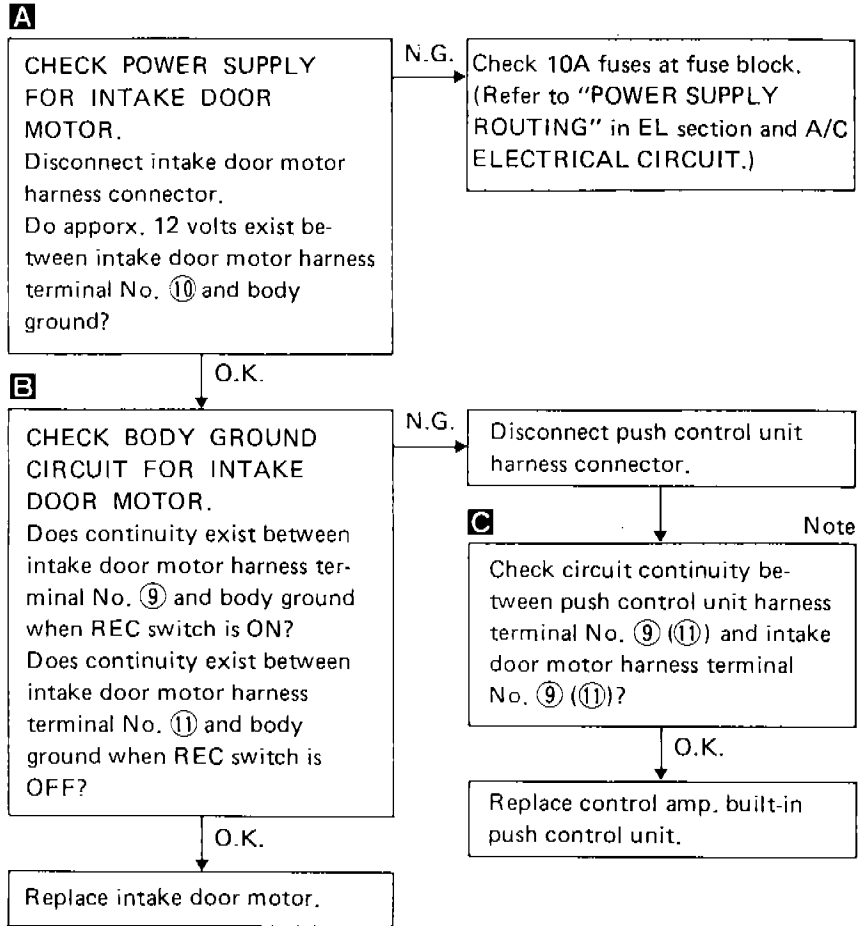

Note:

If the result is N.G. after checking circuit continuity, repair harness or connector.

TROUBLE DIAGNOSES

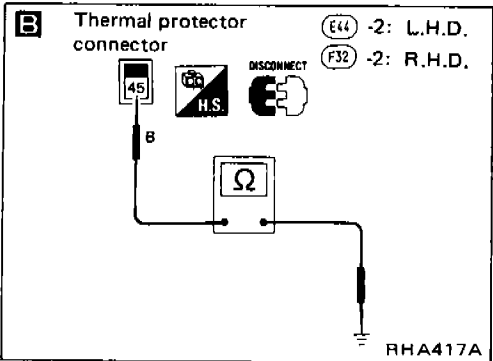
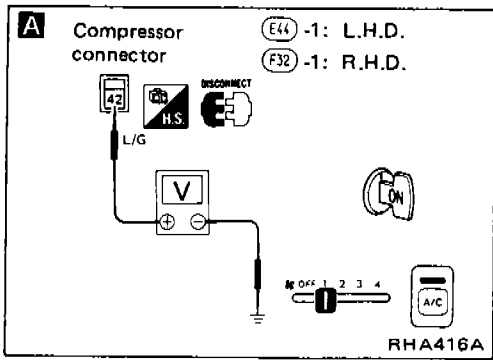

Diagnostic Procedure 4

SYMPTOM: Magnet clutch does not operate with A/C switch and fan switch are ON.

- Perform PRELIMINARY CHECK 2 before referring to the following flow chart.

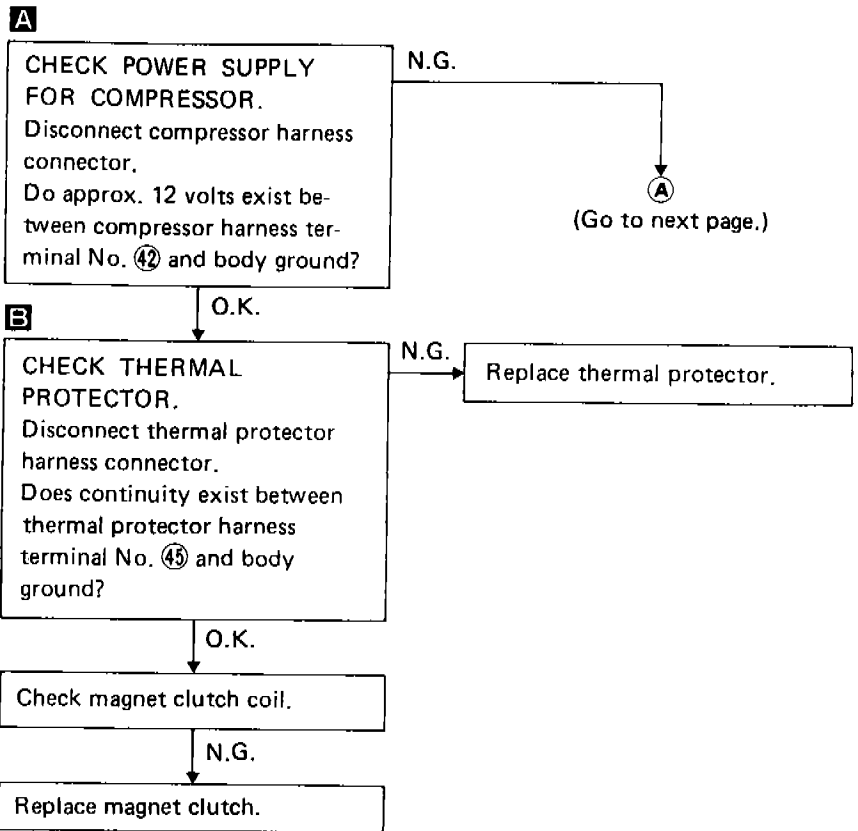

TROUBLE DIAGNOSES

Diagnostic Procedure 4 (Cont'd)

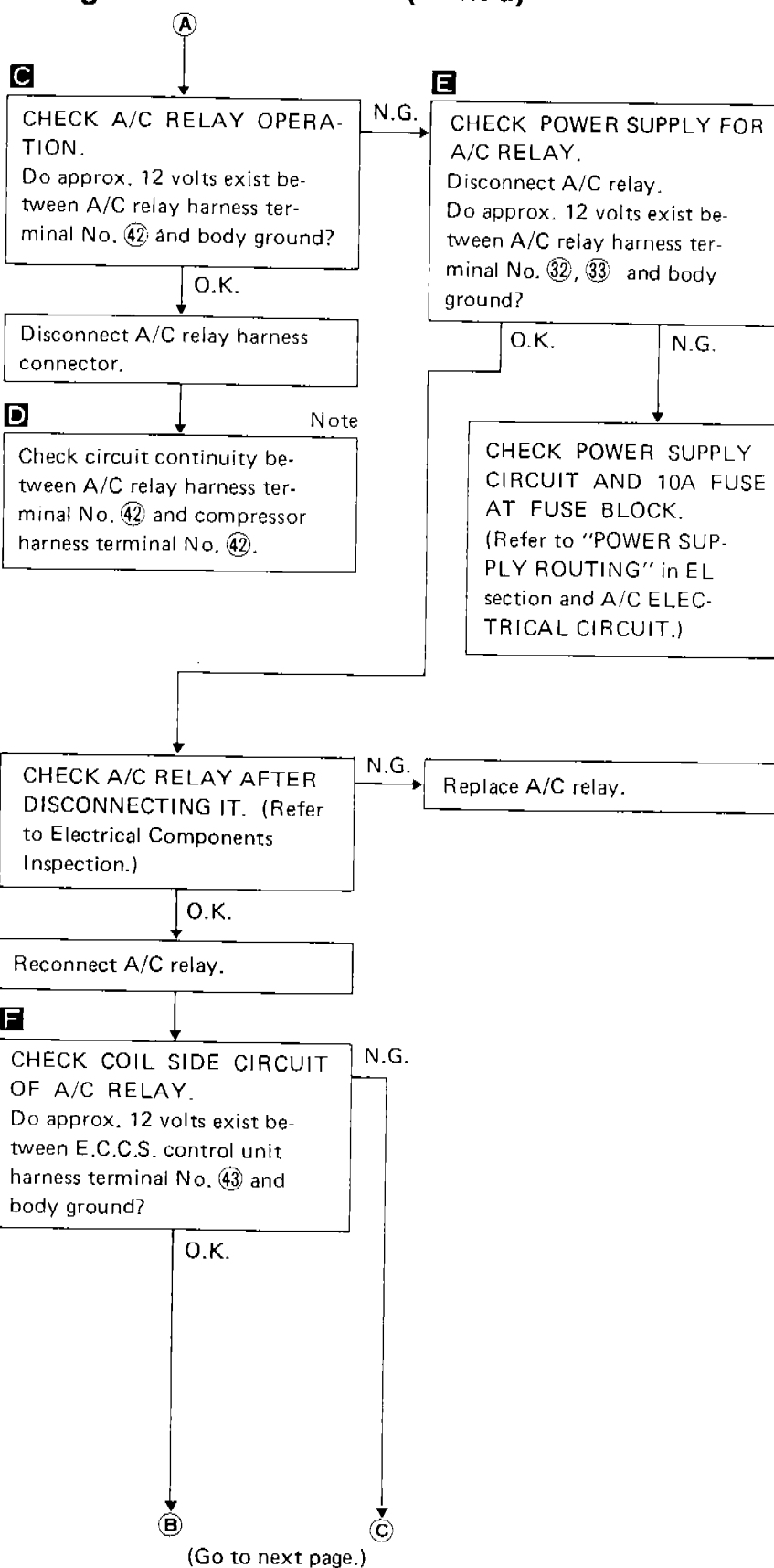
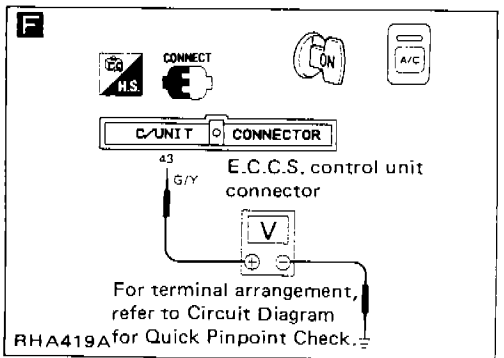
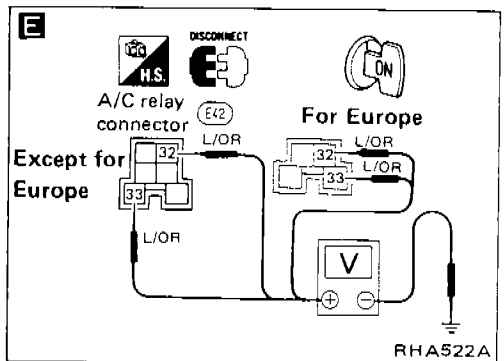
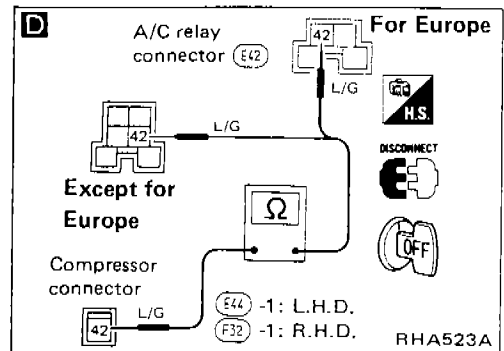
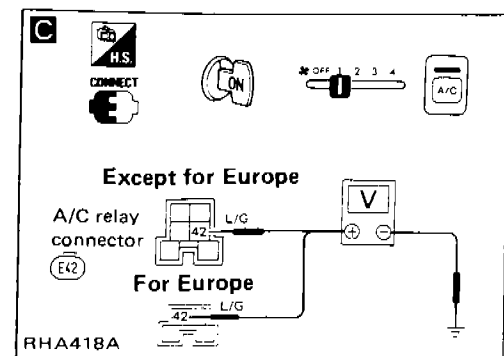

Note:

If the result is N.G. after checking circuit continuity, repair harness or connector.

TROUBLE DIAGNOSES

Diagnostic Procedure 4 (Cont'd)

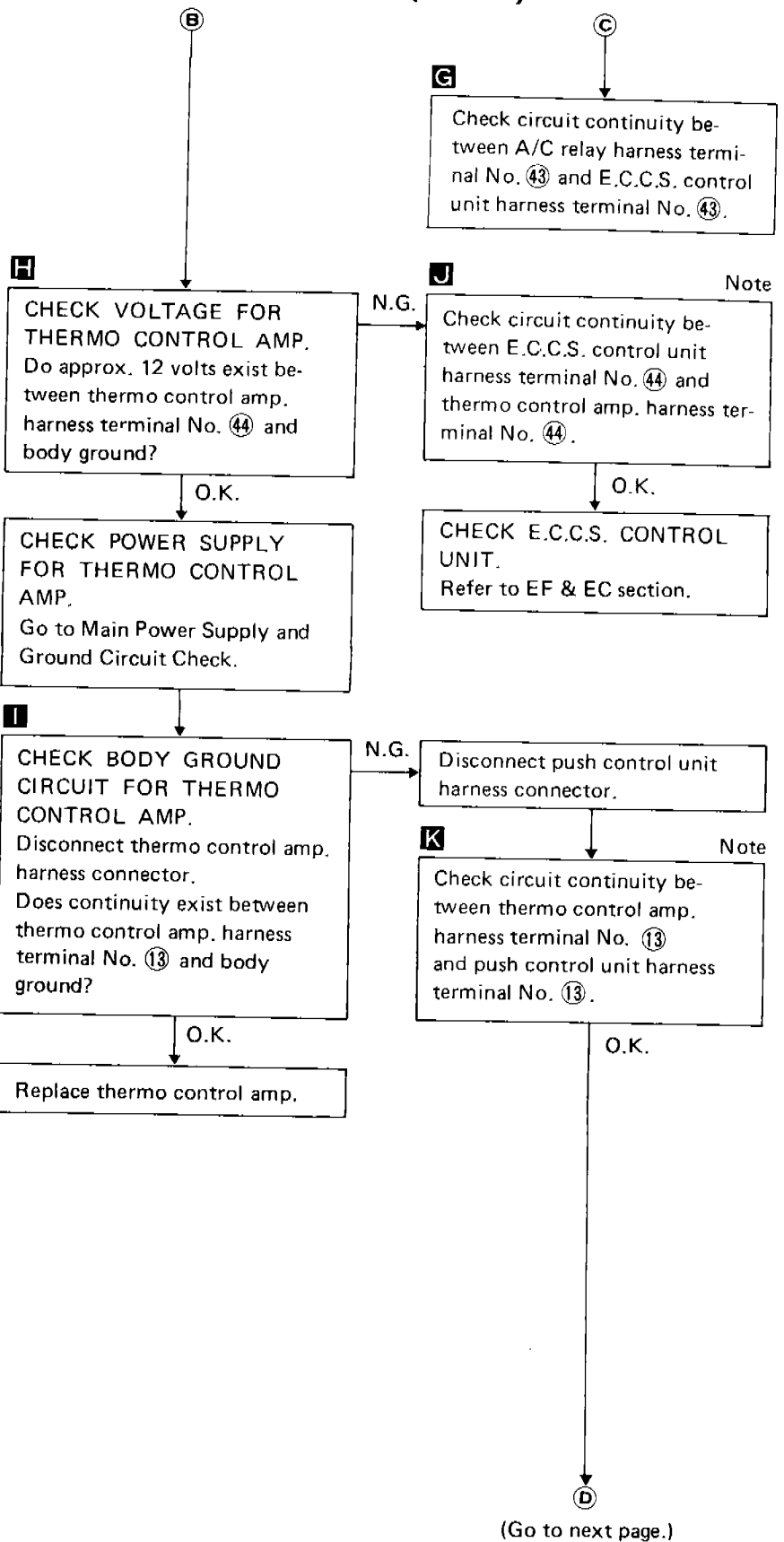
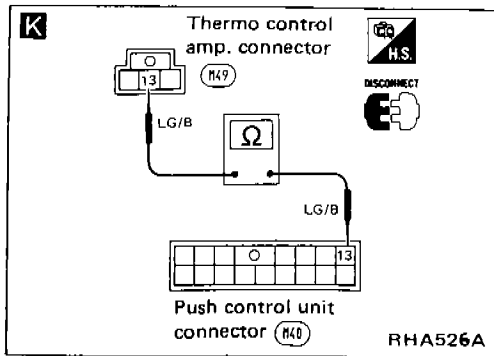
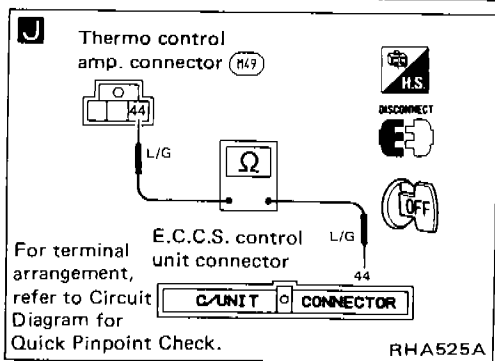
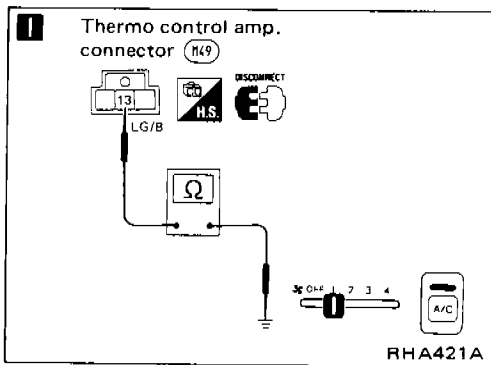
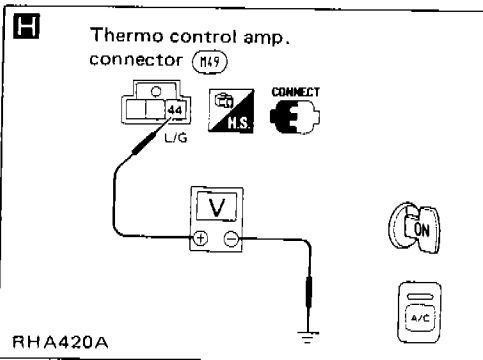
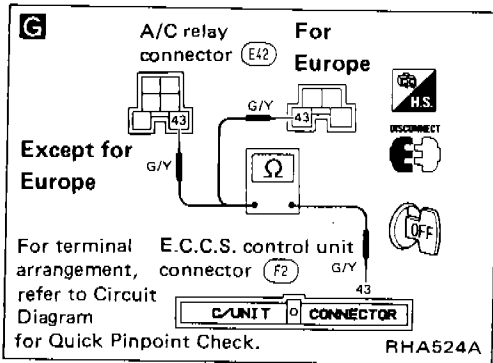

Note:

If the result is N.G. after checking circuit continuity, repair harness or connector.

TROUBLE DIAGNOSES

Diagnostic Procedure 4 (Cont'd)

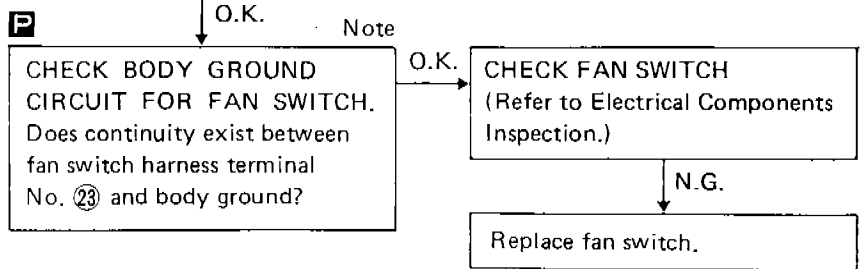
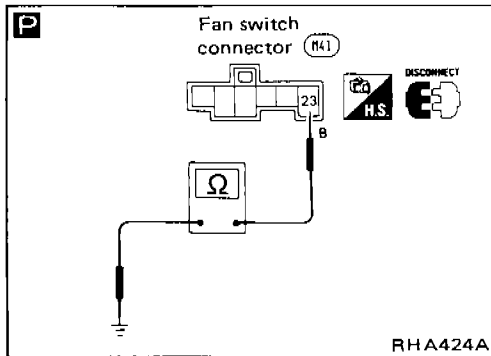
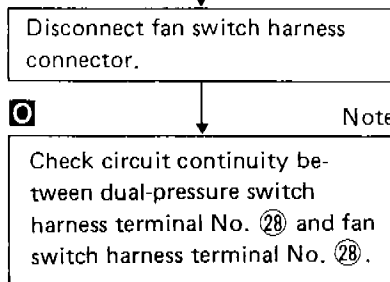
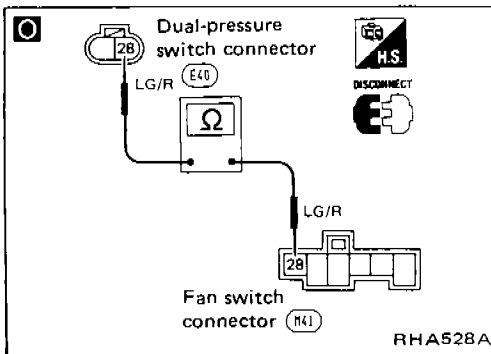
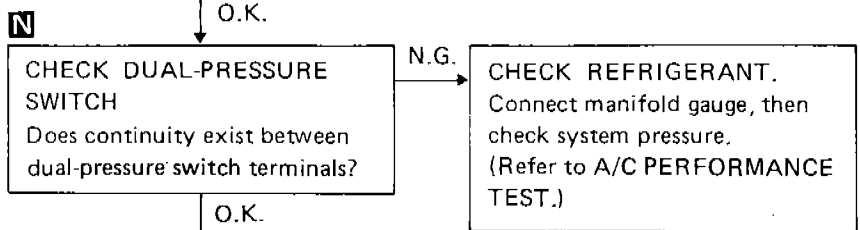
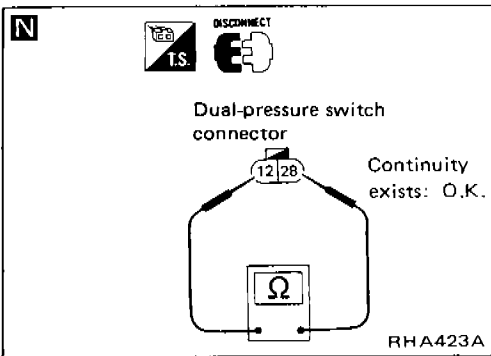
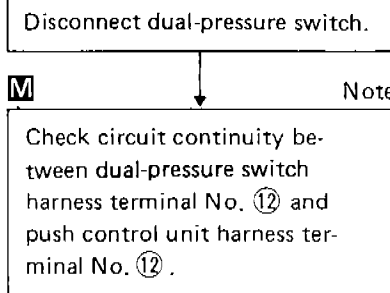
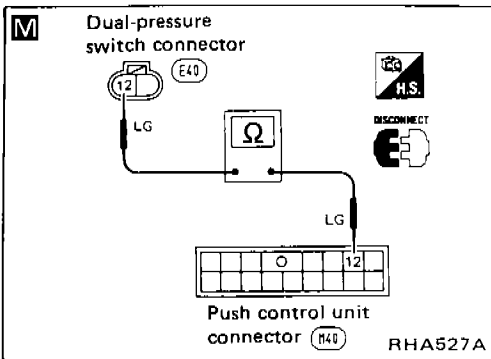
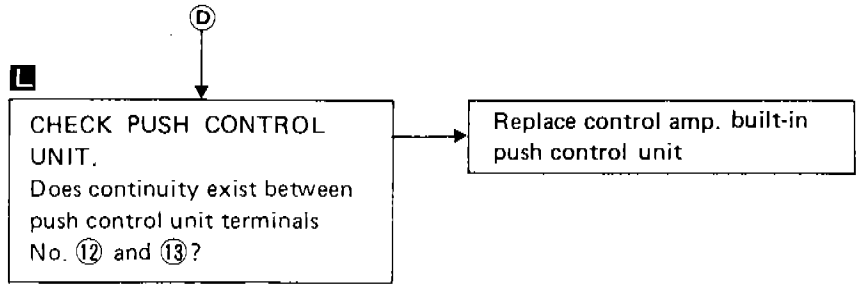
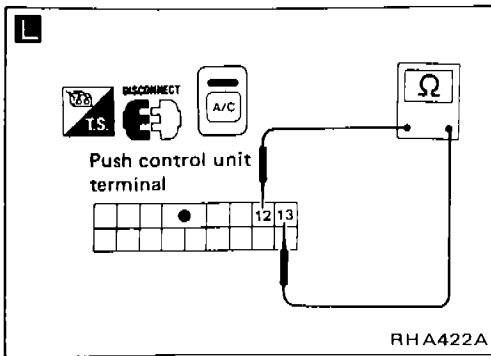

Note:

If the result is N.G. after checking circuit continuity, repair harness or connector.

TROUBLE DIAGNOSES

Diagnostic Procedure 5

SYMPTOM: Illumination or indicators of push control unit do not come on.

- Perform Main Power Supply and Ground Circuit Check before referring to the following flow chart.

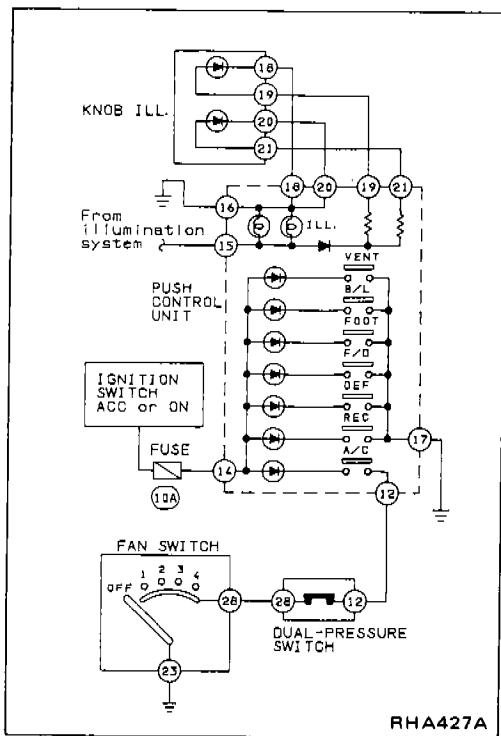

Turn ignition switch and lighting switch ON.

CHECK ILLUMINATION AND INDICATORS.

- Turn A/C, REC and fan switches ON.
- Push VENT, B/L, FOOT, F/D and DEF switches in order.
- Check for incidents and follow the repairing methods as shown:

| INCIDENTS | | | | | | | | "How to repair" |
|-----------|------|-----|------|-----|-----|-----|-----|--------------------------------------------------|
| ILL. | VENT | B/L | FOOT | F/D | DEF | REC | A/C | |
| X | ○ | ○ | ○ | ○ | ○ | ○ | ○ | Go to DIAGNOSTIC PROCEDURE 5-1. |
| ○ | ○ | ○ | ○ | ○ | ○ | ○ | X | Go to DIAGNOSTIC PROCEDURE 5-2. |
| ○ | X | X | X | X | X | X | ○ | Go to DIAGNOSTIC PROCEDURE 5-3. |
| ○ | △ | | | | | | ○ | Replace control amp. built-in push control unit. |
| ○ | X | X | X | X | X | X | ○ | Replace control amp. built-in push control nit. |
| ○ | X | X | X | X | X | X | ○ | Go to DIAGNOSTIC PROCEDURE 5-4. |

○: Illumination or indicator comes on.

X: Illumination or indicator does not come on.

△: Some indicators for VENT, B/L, FOOT, F/D, DEF or REC come on.

DIAGNOSTIC PROCEDURE 5-1

CHECK OTHER ILLUMINATION SYSTEMS EXCEPT FOR A/C SYSTEM.

Does other illumination come on with ignition switch and lighting switch ON?

N.G.

CHECK ILLUMINATION SYSTEM.
Refer to illumination/Wiring Diagram in EL section.

O.K.

Turn ignition switch and lighting switch OFF.

CHECK ILLUMINATION BULB.

Remove push control unit and disconnect harness connectors. Remove illumination bulb(s) and check them.

N.G.

Replace illumination bulb(s).

O.K.

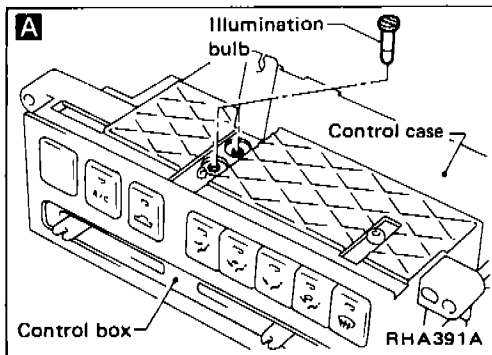

(Go to next page.)

TROUBLE DIAGNOSES

Diagnostic Procedure 5 (Cont'd)

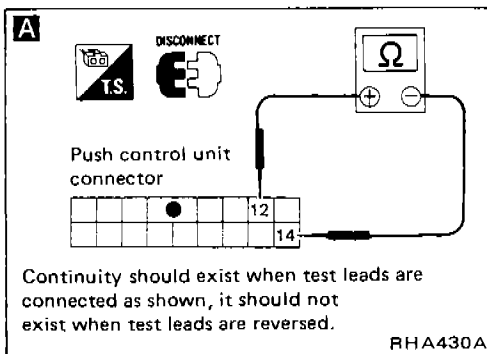
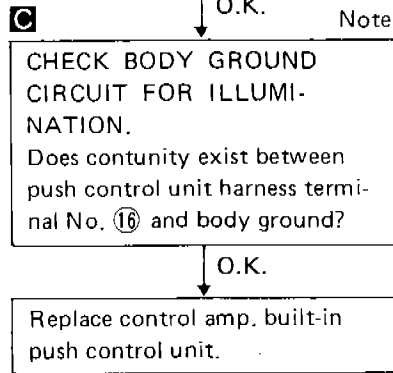
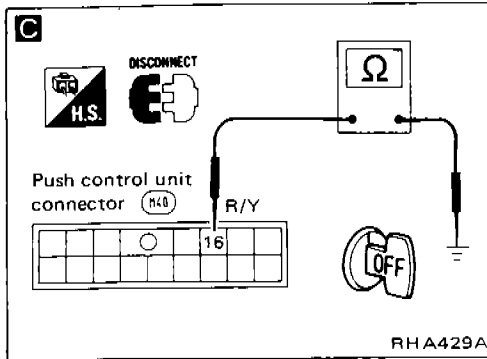
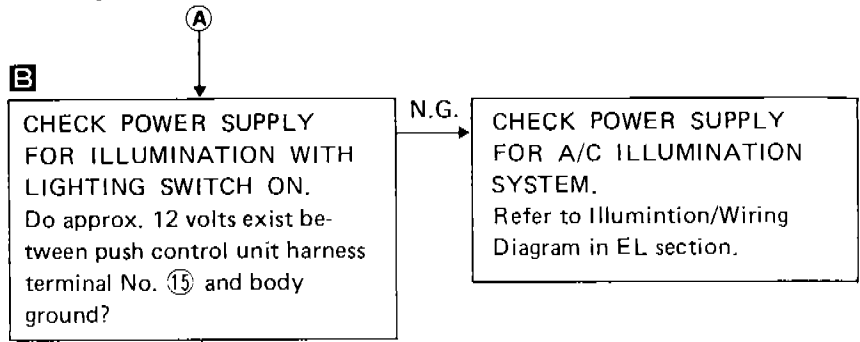
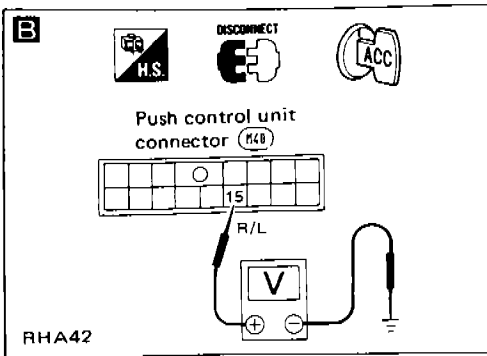

DIAGNOSTIC PROCEDURE 5-2

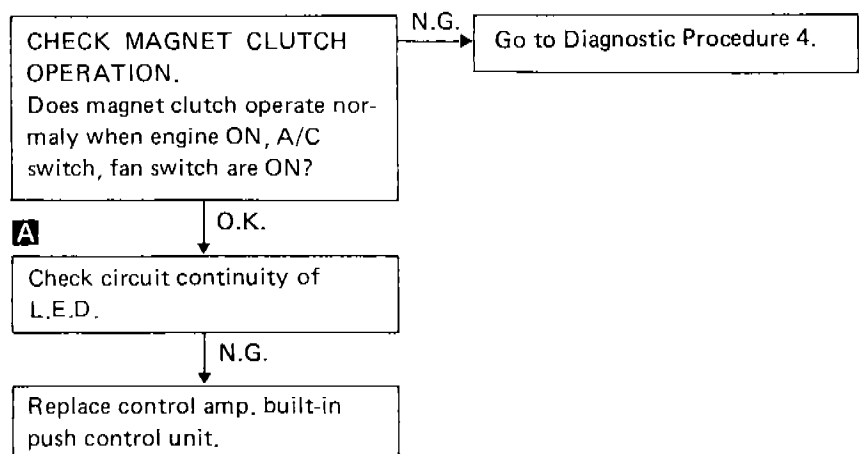

Note:

If the result is N.G. after checking circuit continuity, repair harness or connector.

TROUBLE DIAGNOSES

Diagnostic Procedure 5 (Cont'd)

DIAGNOSTIC PROCEDURE 5-3

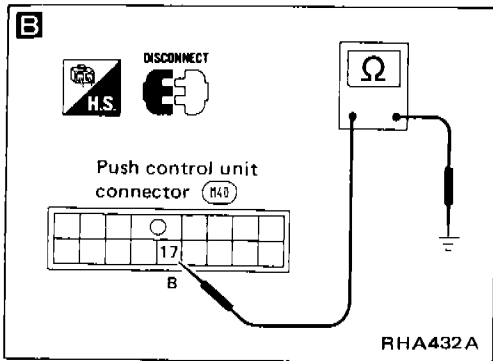
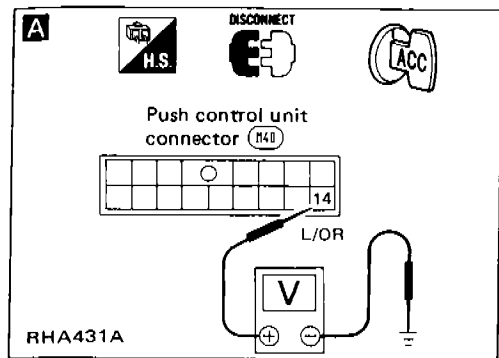

Turn ignition switch and lighting switch OFF.

Disconnect push control unit harness connector.

A

CHECK POWER SUPPLY FOR PUSH CONTROL UNIT. Do approx. 12 volts exist between push control unit harness terminal No. ⑭ and body ground?

N.G. Check 10A fuse at fuse block. (Refer to "POWER SUPPLY ROUTING" in EL section and A/C ELECTRICAL CIRCUIT.)

B

O.K. Note

CHECK BODY GROUND CIRCUIT FOR PUSH CONTROL UNIT. Does continuity exist between push control unit harness terminal No. ⑰ and body ground?

O.K.

Replace control amp. built-in push control unit.

Note:

If the result is N.G. after checking circuit continuity, repair harness or connector.

TROUBLE DIAGNOSES

Diagnostic Procedure 5 (Cont'd)

DIAGNOSTIC PROCEDURE 5-4

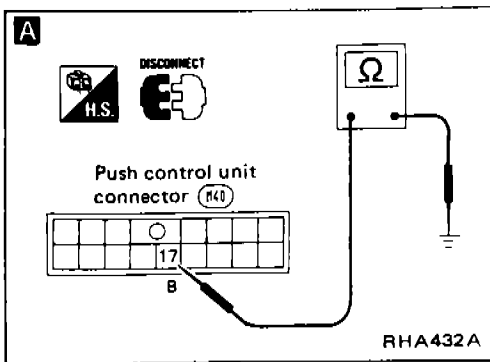

Turn ignition switch and lighting switch OFF.

Disconnect push control unit harness connector.

A Note

CHECK BODY GROUND CIRCUIT FOR PUSH CONTROL UNIT.
Does continuity exist between push control unit harness terminal No. ⑰ and body ground?

O.K.

Replace control amp. built-in push control unit.

Note:

If the result is N.G. after checking circuit continuity, repair harness or connector.

TROUBLE DIAGNOSES

Electrical Components Inspection

FAN SWITCH

Check continuity between terminals at each switch position.

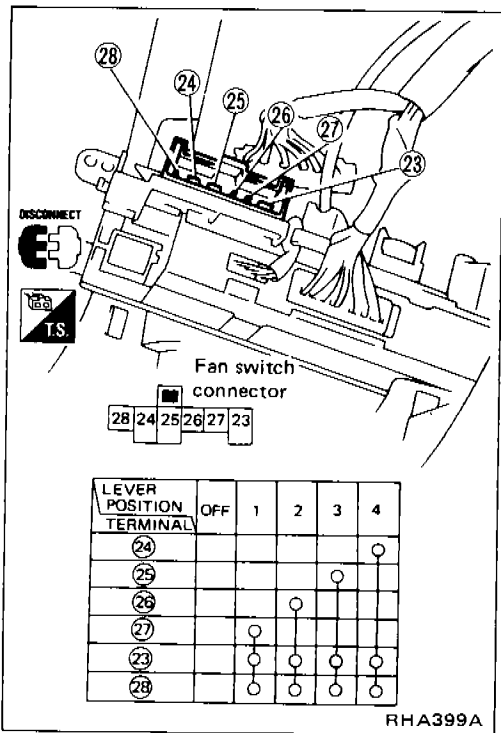

BLOWER MOTOR

Confirm smooth rotation of the blower motor.

- Ensure that there are no foreign particles inside the intake unit.

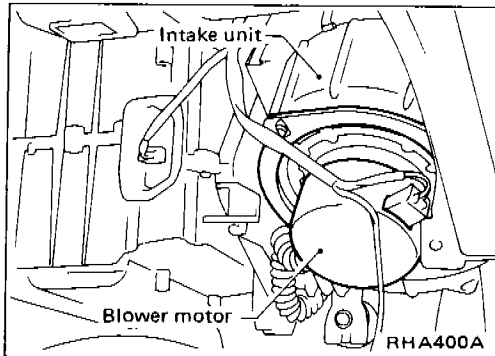

BLOWER RESISTOR

Check continuity between terminals.

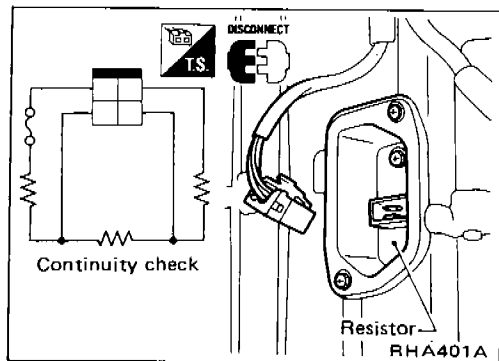

TROUBLE DIAGNOSES

Electrical Components Inspection (Cont'd)

A/C SWITCH

Check continuity between terminals at each switch position.

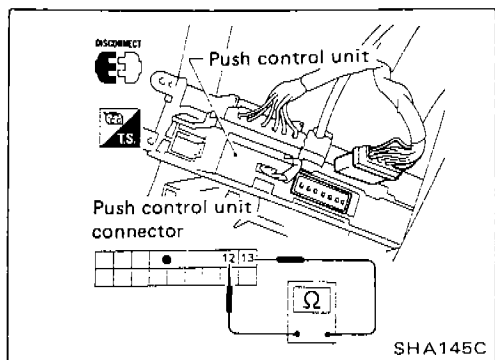

| Switch condition | | | Terminal No. | | Continuity |
|------------------|-----|--------|--------------|----|------------|
| L.H.D. | | R.H.D. | ⊕ | ⊖ | |
| A/C | DEF | A/C | | | |
| ON | ON | ON | | | Exists |
| ON | OFF | | 13 | 12 | |
| OFF | ON | | | | |

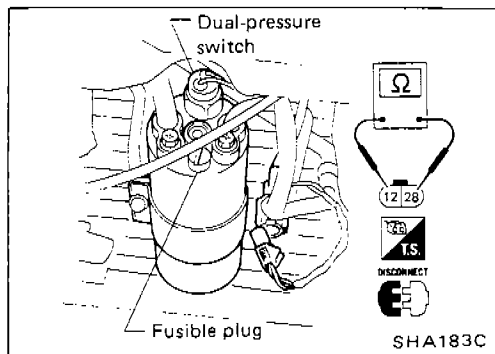

DUAL-PRESSURE SWITCH

| High-pressure side line pressure kPa (bar, kg/cm ² , psi) | Operation | Continuity |
|----------------------------------------------------------------------------------------------------------------------------------------|-----------|----------------|
| Decreasing to 177 - 216 (1.77 - 2.16, 1.8 - 2.2, 26 - 31) Increasing to 2,452 - 2,844 (24.5 - 28.4, 25 - 29, 356 - 412) | Turn OFF | Does not exist |
| Increasing to 177 - 235 (1.77 - 2.35, 1.8 - 2.4, 26 - 34) Decreasing to 1,863 - 2,256 (18.6 - 22.6, 19 - 23, 270 - 327) | Turn ON | Exists |

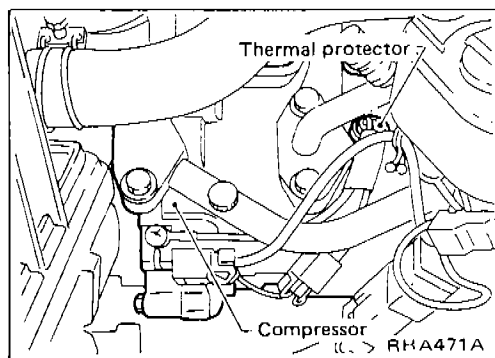

THERMAL PROTECTOR

| Temperature of compressor °C (°F) | Operation |
|---------------------------------------------|-----------|
| Increasing to approx. 135 - 145 (275 - 293) | Turn OFF |
| Decreasing to approx. 120 - 130 (248 - 266) | Turn ON |

TROUBLE DIAGNOSES

Electrical Components Inspection (Cont'd)

THERMO CONTROL AMP.

1. Run engine, and operate A/C system.
2. Connect the voltmeter from harness side.
3. Check thermo control amp. operation shown in the table.

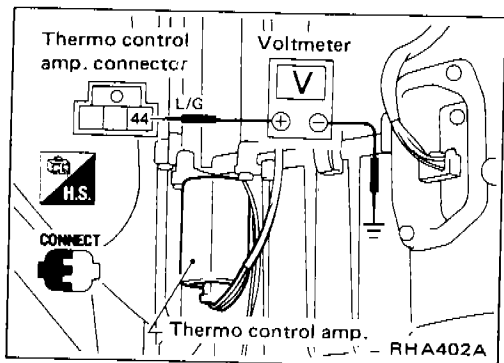

| Evaporator outlet air temperature °C (°F) | Thermo amp. operation | Tester |
|----------------------------------------------|--------------------------|-------------|
| Decreasing to 1.5 - 2.5 (35 - 37) | Turn OFF | Approx. 12V |
| Increasing to 3.0 - 4.0 (37 - 39) | Turn ON | Approx. 0V |

A/C RELAY

Check circuit continuity between terminals by supplying 12 volts to coil side terminal of A/C relay.

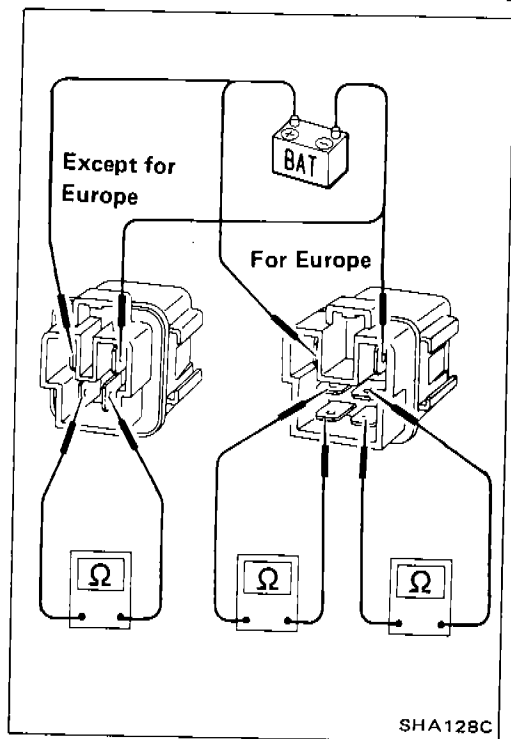

THERMOSWITCH (For hot areas)

| Water temperature °C (°F) | Operation | Continuity |
|--------------------------------------|-----------|----------------|
| Decreasing to 85 - 91 (185 - 196) | Turn OFF | Does not exist |
| Increasing to 92 - 98 (198 - 208) | Turn ON | Exists |

SERVICE DATA AND SPECIFICATIONS (S.D.S.)

General Specifications

COMPRESSOR

| | L.H.D. | R.H.D. |
|-------------------------------------------|--------------------------------------|--------------------------------|
| Model | ATSUGI make NVR 140S | DIESEL-KIKI make DKV-14C |
| Type | Vane rotary | |
| Displacement cm ³ (cu in)/rev. | 140 (8.54) | |
| Direction of rotation | Clockwise (Viewed from drive end) | |
| Drive belt | Poly V | |

LUBRICATION OIL

| Type | SUNISO 5GS |
|-----------------------------------------------|-------------------|
| Capacity ml (Imp fl oz) Total in system | 200 (7.0) |
| Amount of oil which can be drained | Approx. 100 (3.5) |
| Compressor (Service parts) charging amount | 200 (7.0) |

REFRIGERANT

| Type | R-12 |
|--------------------------------|---------------------------|
| Capacity kg (lb) For Europe | 0.85 - 0.95 (1.87 - 2.09) |
| Except Europe L.H.D. model | 0.9 - 1.0 (2.0 - 2.2) |
| R.H.D. model | 0.8 - 0.9 (1.8 - 2.0) |

Inspection and Adjustment

ENGINE IDLING SPEED (When A/C is ON.)

- Refer to EF & EC section.

BELT TENSION

- Refer to Checking Drive Belts (MA section).

COMPRESSOR

| Model | NVR 140S | DKV-14C |
|-----------------------------------------|------------------------------|---------|
| Clutch disc-pulley clearance mm (in) | 0.3 - 0.6 (0.012 - 0.024) | |

ELECTRICAL SYSTEM

SECTION **EL**

When you read wiring diagrams:

- Read GI section, "HOW TO READ WIRING DIAGRAMS".

CONTENTS

| | |
|-----------------------------------------|--------|
| HARNESS CONNECTOR | EL- 2 |
| STANDARDIZED RELAY | EL- 3 |
| POWER SUPPLY ROUTING | EL- 5 |
| BATTERY | EL- 9 |
| STARTING SYSTEM | EL- 17 |
| STARTING SYSTEM — Starter — | EL- 19 |
| CHARGING SYSTEM | EL- 25 |
| CHARGING SYSTEM — Alternator — | EL- 27 |
| COMBINATION SWITCH | EL- 32 |
| HEADLAMP | EL- 34 |
| EXTERIOR LAMP | EL- 47 |
| INTERIOR LAMP | EL- 55 |
| METER AND GAUGES | EL- 57 |
| WARNING LAMPS AND CHIME | EL- 61 |
| WIPER AND WASHER | EL- 65 |
| HORN, CIGARETTE LIGHTER AND CLOCK | EL- 73 |
| REAR WINDOW DEFOGGER | EL- 74 |
| AUDIO AND POWER ANTENNA | EL- 77 |
| LOCATION OF ELECTRICAL UNITS | EL- 81 |
| HARNESS LAYOUT | EL- 83 |
| SUPER MULTIPLE JUNCTION (S.M.J.) | EL-107 |

WIRING DIAGRAM REFERENCE CHART

| | |
|-----------------------------------------------------------|-----------------|
| E.C.C.S. (Ignition system) | EF & EC SECTION |
| A/T CONTROL | AT SECTION |
| DIFFERENTIAL OIL COOLER | PD SECTION |
| 4-WHEEL SKID CONTROL | BR SECTION |
| ELECTRIC DOOR MIRROR, DOOR LOCK AND POWER WINDOW | BF SECTION |
| HEATER AND AIR CONDITIONER | HA SECTION |

EL

HARNESS CONNECTOR

Description

HARNESS CONNECTOR

- All harness connectors have been modified to prevent accidental looseness or disconnection.
- The connector can be disconnected by pushing or lifting the locking section.

CAUTION:

Do not pull the harness when disconnecting the connector.

[Example]

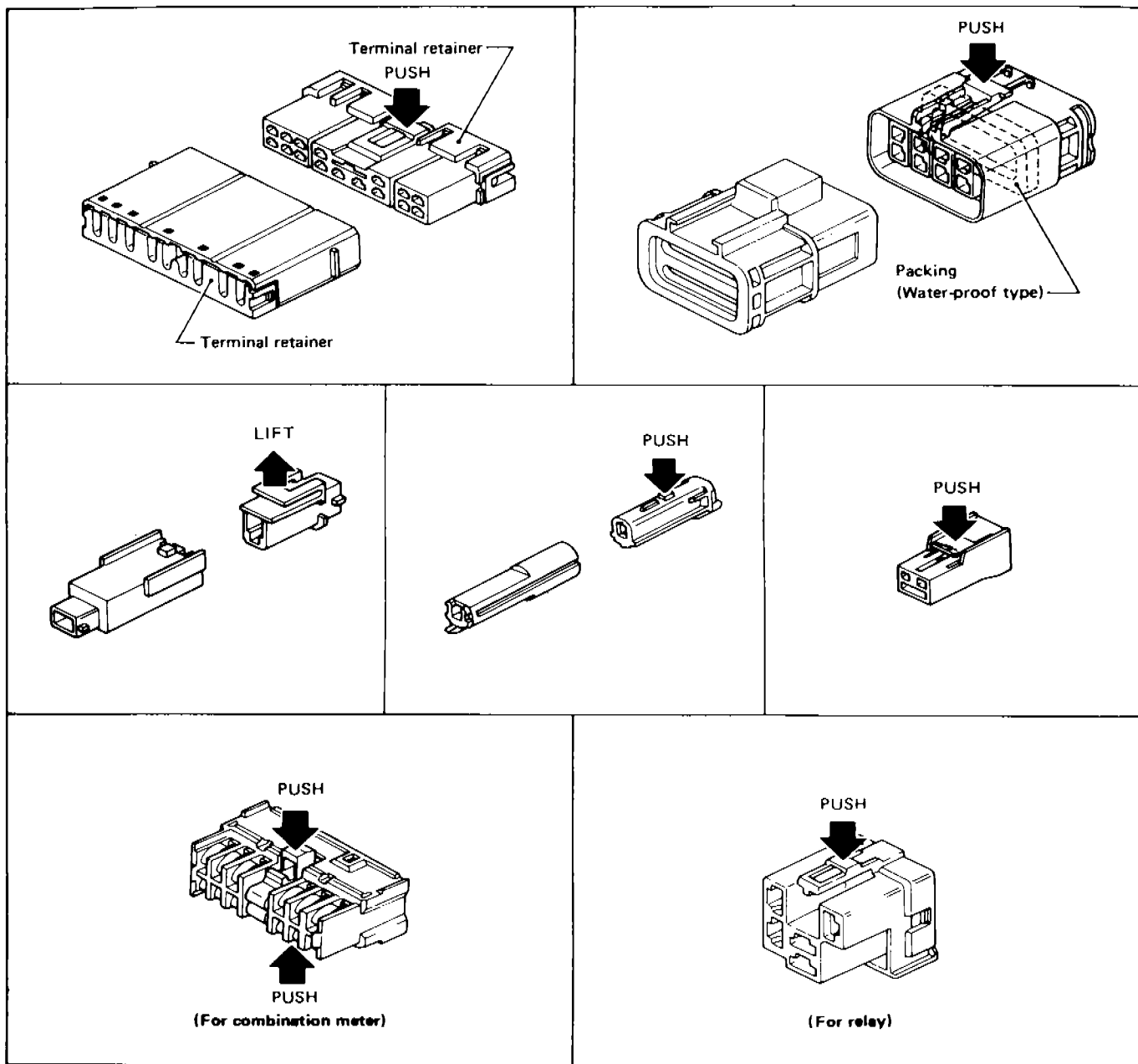

SEL769D

STANDARDIZED RELAY

Description

NORMAL OPEN, NORMAL CLOSED AND MIXED TYPE RELAYS

Relays can mainly be divided into three types: normal open, normal closed and mixed type relays.

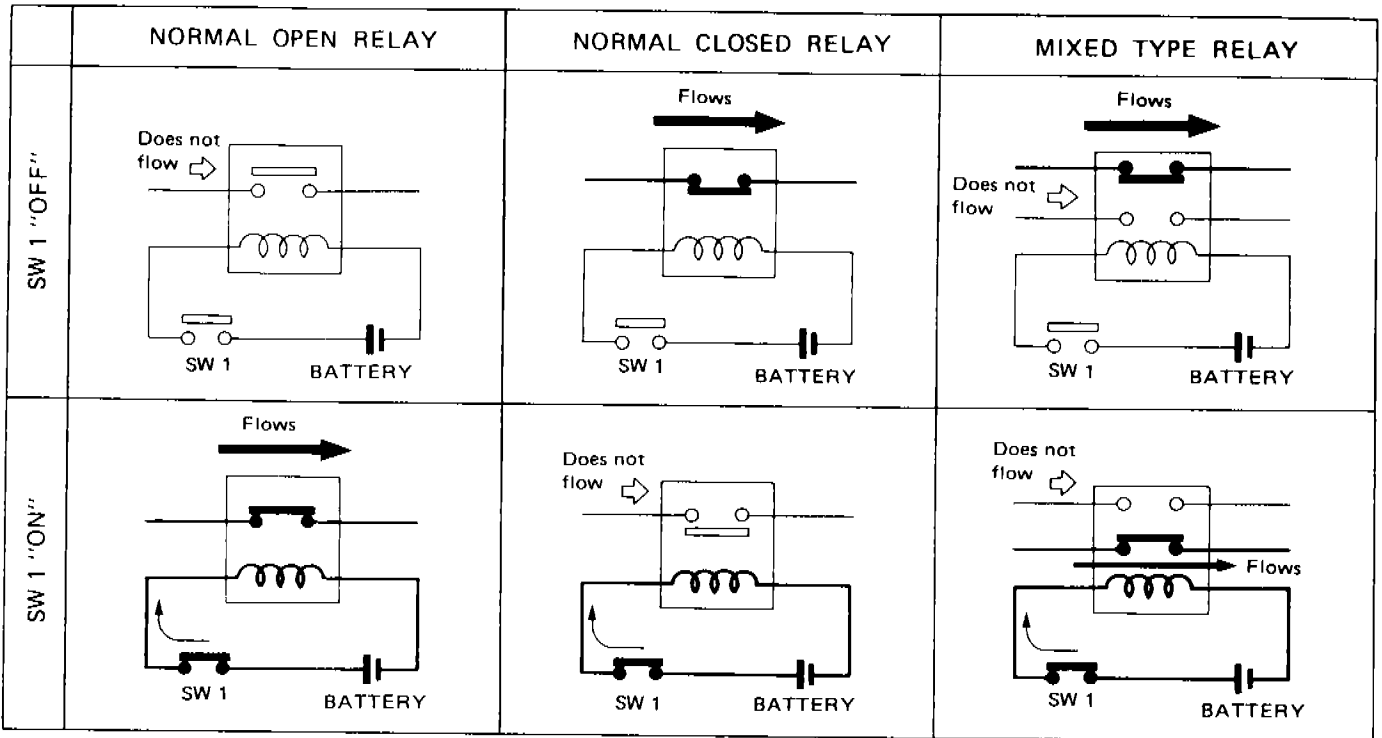

SEL881H

TYPE OF STANDARDIZED RELAYS

1M 1 Make
1T 1 Transfer

2M 2 Make
1M-1B 1 Make 1 Break

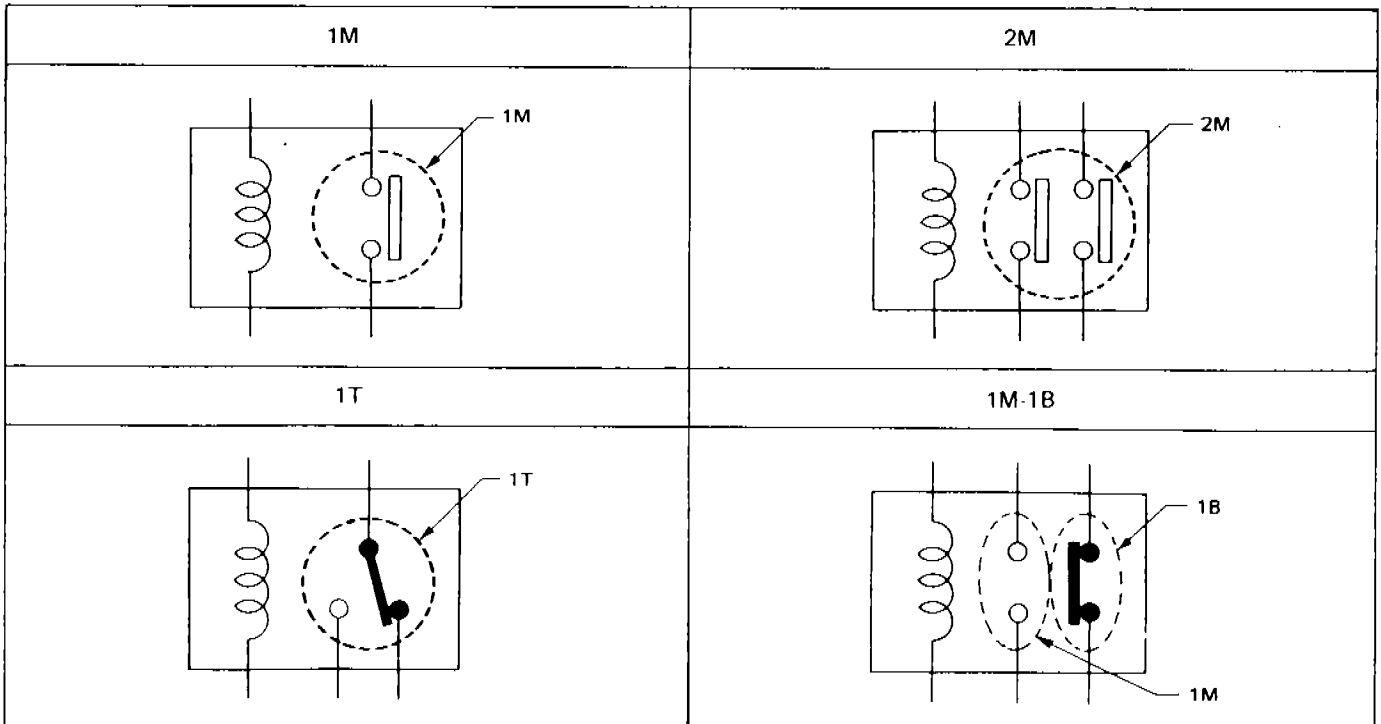

SEL882H

STANDARDIZED RELAY

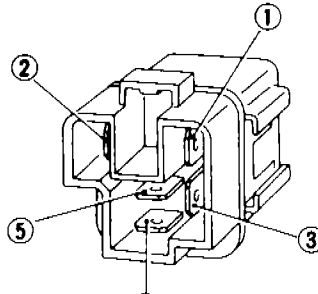
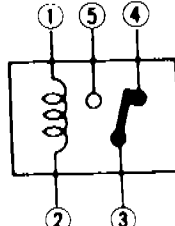
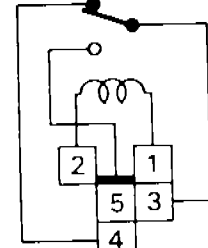
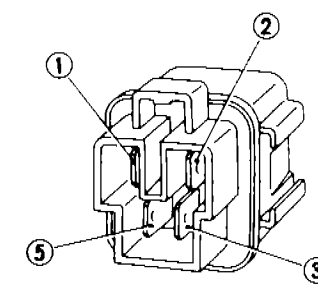
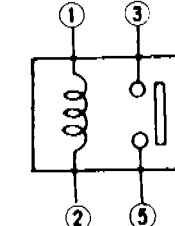
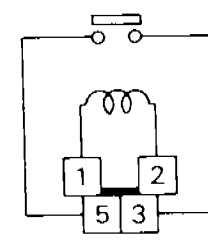
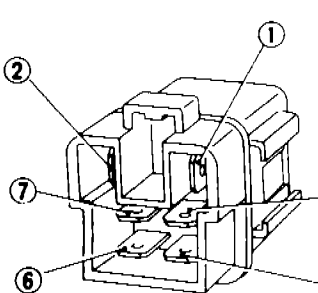
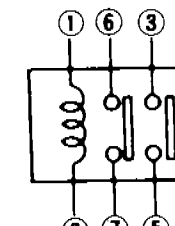
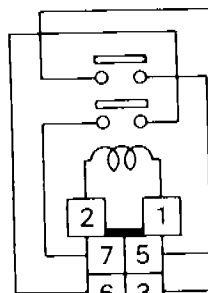
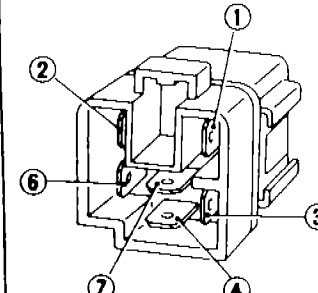
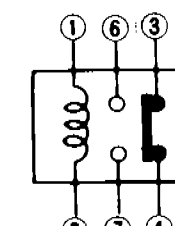
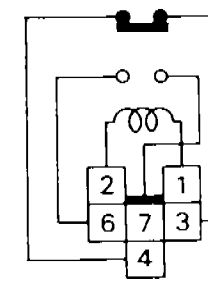
| Type | Outer view | Circuit | Connector symbol and connection | Case color |
|-------|-------------------------------------------------------------------------------------|-------------------------------------------------------------------------------------|--------------------------------------------------------------------------------------|------------|
| 1T |  |  |  | BLACK |
| 1M |  |  |  | BLUE |
| 2M |  |  |  | BROWN |
| 1M-1B |  |  |  | GRAY |

SEL883H

POWER SUPPLY ROUTING

Wiring Diagram (Cont'd)

EXCEPT L.H. DRIVE MODEL FOR EUROPE

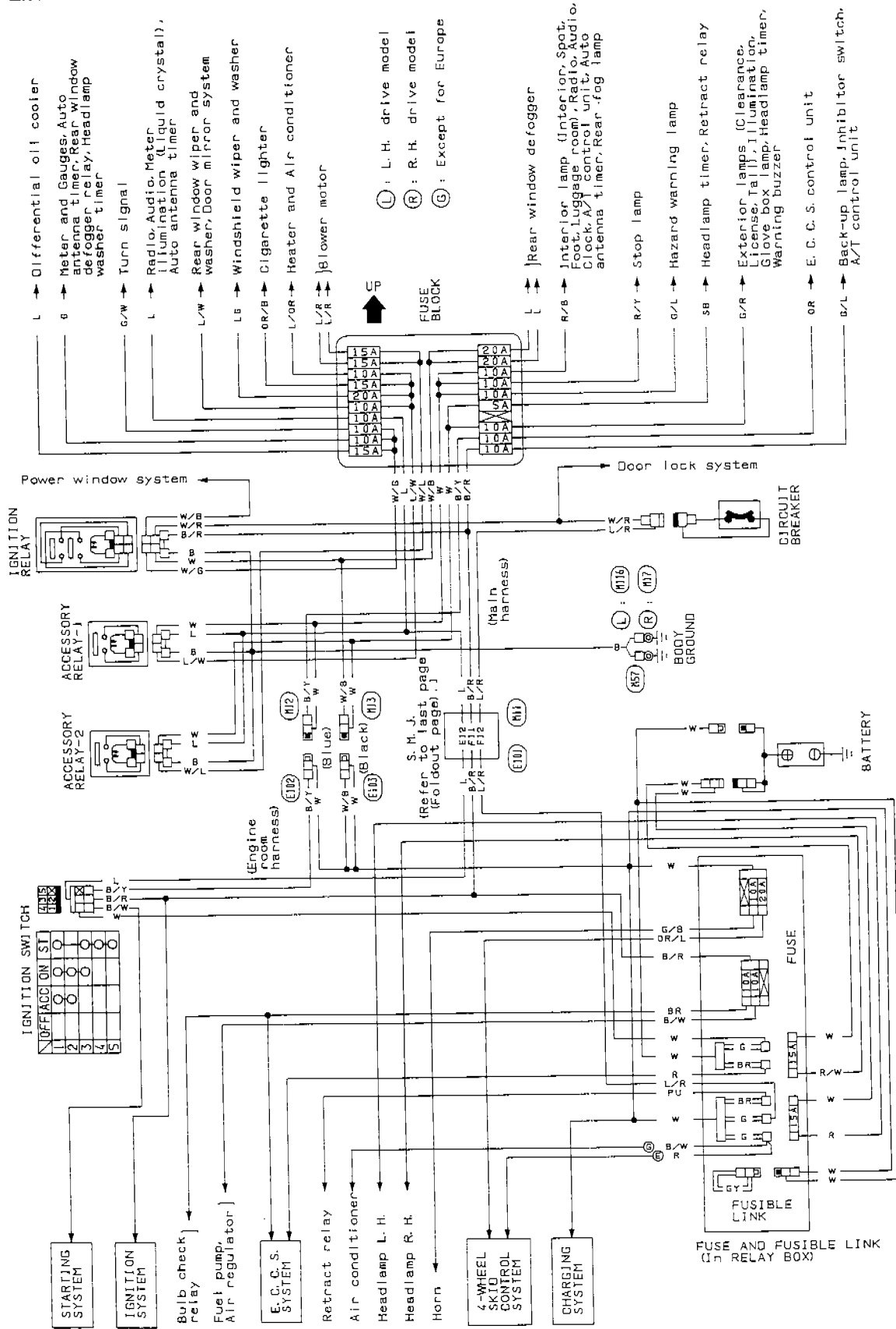

SEL765L

POWER SUPPLY ROUTING

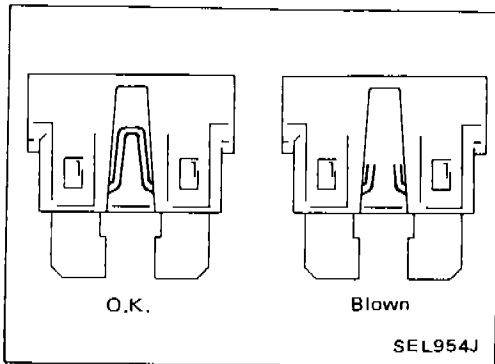

Fuse

- If fuse is blown, be sure to eliminate cause of problem before installing new fuse.
- Use fuse of specified rating. Never use fuse of more than specified rating.
- Do not install fuse in oblique direction; always insert it into fuse holder properly.
- Remove fuse for clock if vehicle is not used for a long period of time.

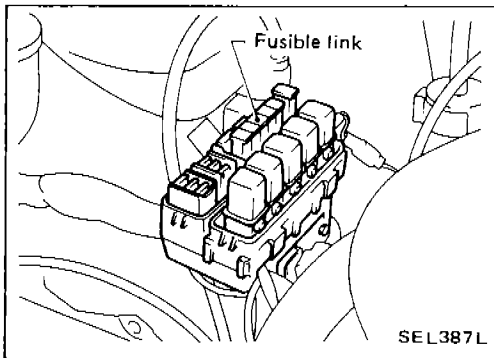

Fusible Link

A melted fusible link can be detected by visual inspection. If its condition is questionable, use circuit tester or test lamp.

CAUTION:

- If fusible link should melt, it is possible that critical circuit (power supply or large current carrying circuit) is shorted. In such a case, carefully check and eliminate cause of problem.
- Never wrap periphery of fusible link with vinyl tape. Extreme care should be taken with this link to ensure that it does not come into contact with any other wiring harness or vinyl or rubber parts.

POWER SUPPLY ROUTING

NOTE

EL-8

BATTERY

CAUTION:

- If it becomes necessary to start the engine with a booster battery and jumper cables, use a 12-volt booster battery.
- After connecting battery cables, ensure that they are tightly clamped to battery terminals for good contact.
- Never add distilled water through the hole used to check specific gravity.

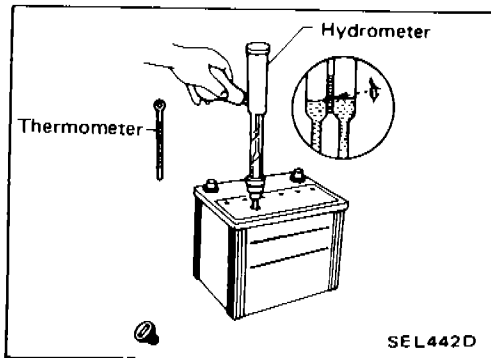
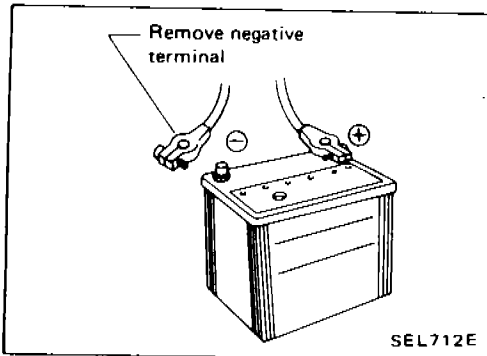
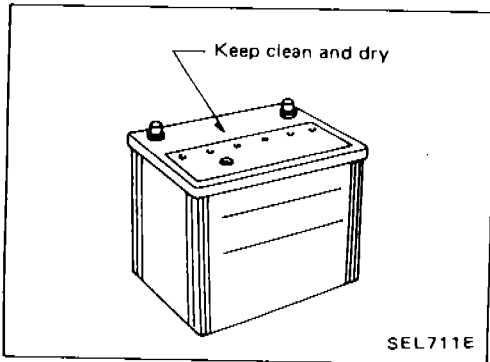

How to Handle Battery

METHODS OF PREVENTING OVER-DISCHARGE

The following precautions must be taken to prevent over-discharging a battery.

- The battery surface (particularly its top) should always be kept clean and dry. If the top surface of a battery is wet with electrolyte or water, leakage current will cause the battery to discharge. Always keep the battery clean and dry.
- When the vehicle is not going to be used over a long period of time, disconnect the negative battery terminal. (If the vehicle has an extended storage switch, turn it off.)
- Check the charge condition of the battery. Periodically check the specific gravity of the electrolyte. Keep a close check on charge condition to prevent over-discharge.

BATTERY

How to Handle Battery (Cont'd)

CHECKING ELECTROLYTE LEVEL

WARNING:

Do not allow battery fluid to come in contact with skin, eyes, fabrics, or painted surfaces. After touching a battery, do not touch or rub your eyes until you have thoroughly washed your hands. If the acid contacts the eyes, skin or clothing, immediately flush with water for 15 minutes and seek medical attention.

Normally the battery does not require additional water. However, when the battery is used under severe conditions, adding distilled water may be necessary during the battery life.

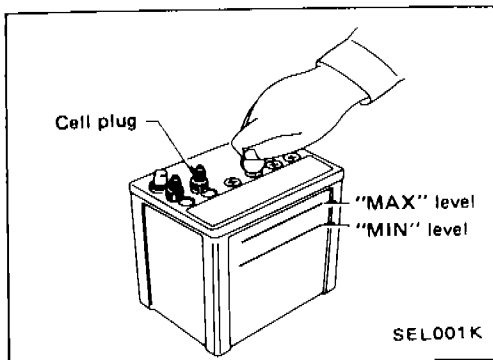

- Remove the cell plug using a suitable tool.
- Add distilled water up to the MAX level.

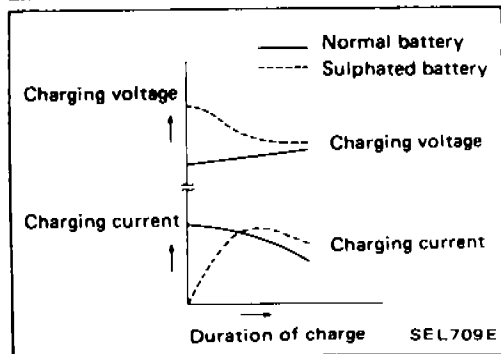

SULPHATION

When a battery has been left unattended for a long period of time and has a specific gravity of less than 1.100, it will be completely discharged, resulting in sulphation on the cell plates. Compared with a battery discharged under normal conditions, the current flow in a "sulphated" battery is not as smooth although its voltage is high during the initial stage of charging, as shown in the figure at the left.

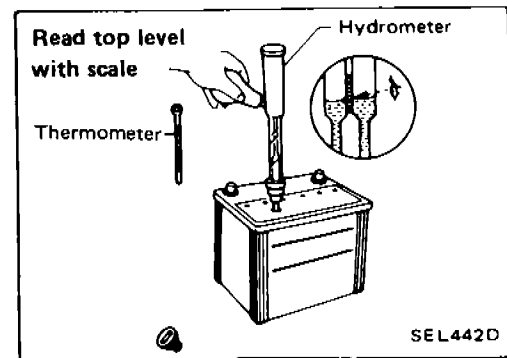

SPECIFIC GRAVITY CHECK

1. Read hydrometer and thermometer indications at eye level.

BATTERY

How to Handle Battery (Cont'd)

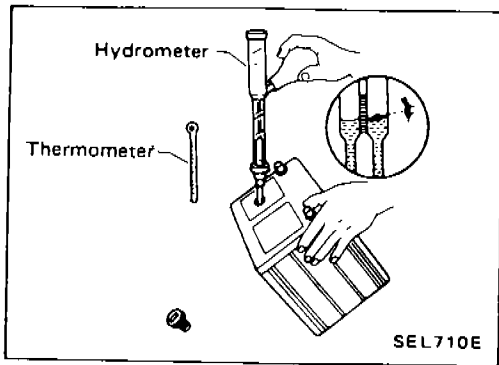

- When electrolyte level is too low, tilt battery case to raise it for easy measurement.

2. Convert into specific gravity at 20° C (68° F).

Example:

- When electrolyte temperature is 35° C (95° F) and specific gravity of electrolyte is 1.230, converted specific gravity at 20° C (68° F) is 1.240.
- When electrolyte temperature is 0° C (32° F) and specific gravity of electrolyte is 1.210, converted specific gravity at 20° C (68° F) is 1.196.

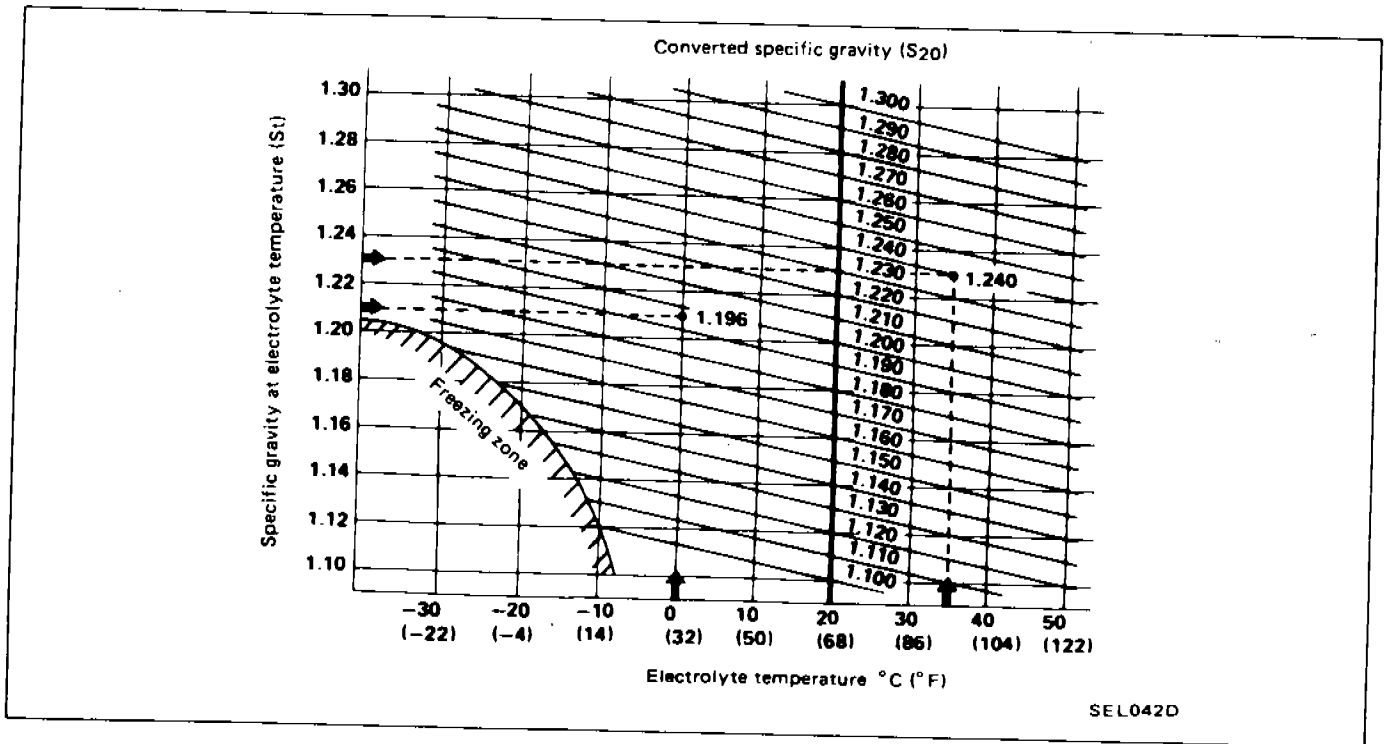

BATTERY

Battery Test and Charging Chart

Chart I

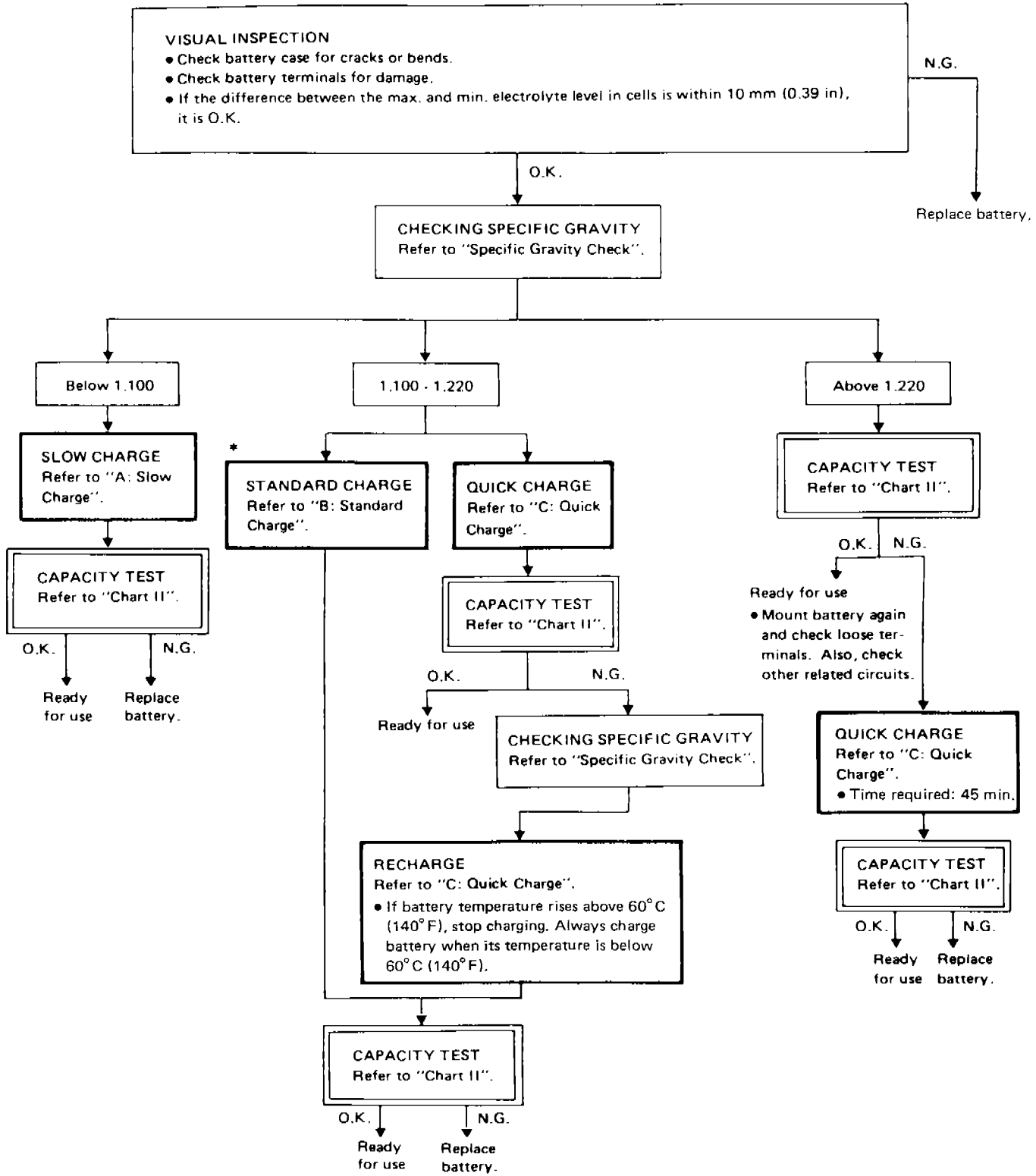

* "STANDARD CHARGE" is recommended in case that the vehicle is in storage after charging.

BATTERY

Battery Test and Charging Chart (Cont'd)

Chart II

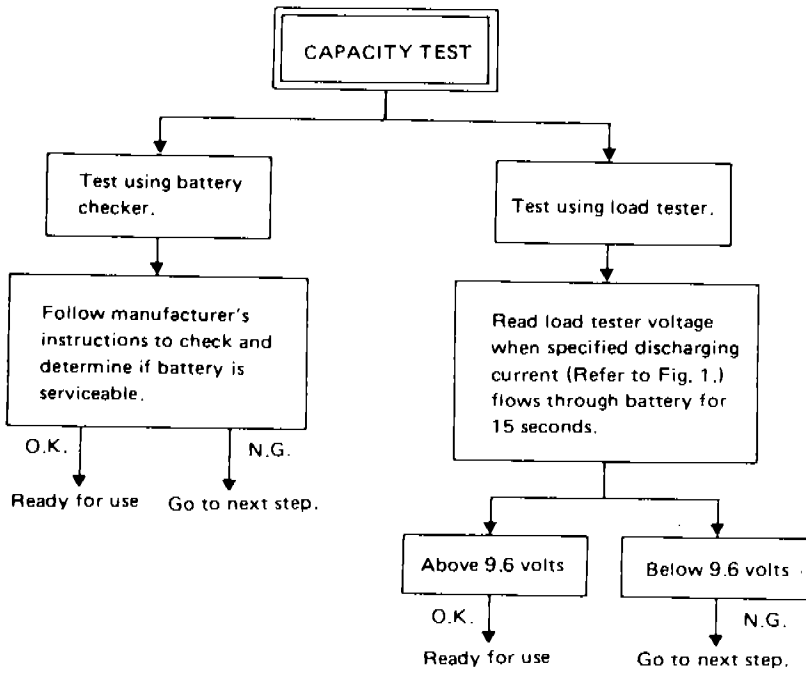

- Check battery type and determine the specified current using the following table.

Fig. 1 DISCHARGING CURRENT (Load tester)

| Type | Current (A) |
|------------|-------------|
| 28B19R(L) | 90 |
| 34B19R(L) | 99 |
| 46B24R(L) | 135 |
| 55B24R(L) | 135 |
| 50D23R(L) | 150 |
| 55D23R(L) | 180 |
| 65D26R(L) | 195 |
| 80D26R(L) | 195 |
| 75D31R(L) | 210 |
| 95D31R(L) | 240 |
| 95E41R(L) | 300 |
| 130E41R(L) | 330 |

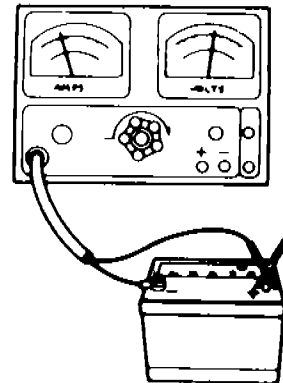

SEL697B

BATTERY

Battery Test and Charging Chart (Cont'd)

A: SLOW CHARGE

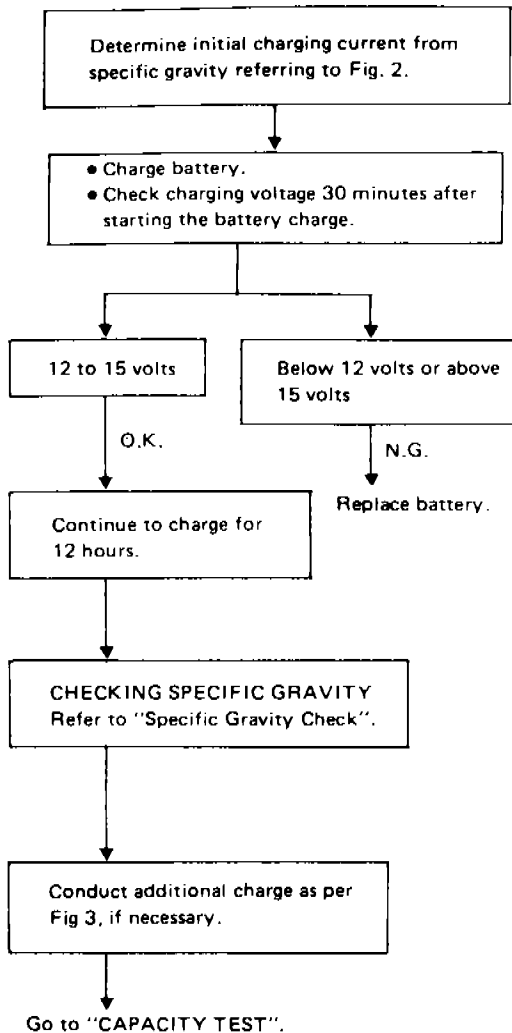
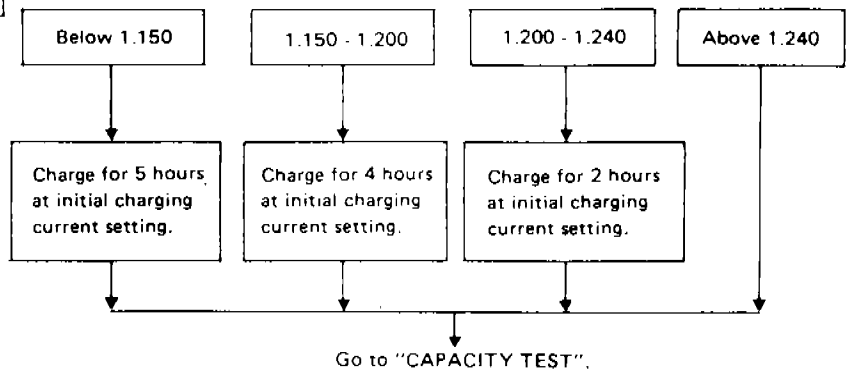

Fig. 2 INITIAL CHARGING CURRENT SETTING (Slow charge)

| BATTERY TYPE CON- VERTED SPECIFIC GRAVITY | 28B19R(L) 34B19R(L) | 46B24R(L) 55B24R(L) | 50D23R(L) 55D23R(L) | 65D26R(L) 80D26R(L) | 75D31R(L) | 95D31R(L) 95E41R(L) | 130E41R(L) |
|-------------------------------------------------------|------------------------|------------------------|------------------------|------------------------|------------|------------------------|-------------|
| Below 1.100 | 4.0 (A) | 5.0 (A) | 7.0 (A) | 8.0 (A) | 9.0 (A) | 10.0 (A) | 14.0 (A) |

- Check battery type and determine the specified current using the table shown above.
- After starting charging, adjustment of charging current is not necessary.

Fig. 3 ADDITIONAL CHARGE (Slow charge)



CAUTION:

- Set charging current to value specified in Fig. 2. If charger is not capable of producing specified current value, set its charging current as close to that value as possible.
- Keep battery away from open flame while it is being charged.
- When connecting charger, connect leads first, then turn on charger. Do not turn on charger first, as this may cause a spark.
- If battery temperature rises above 60°C (140°F), stop charging. Always charge battery when its temperature is below 60°C (140°F).

BATTERY

Battery Test and Charging Chart (Cont'd)

B: STANDARD CHARGE

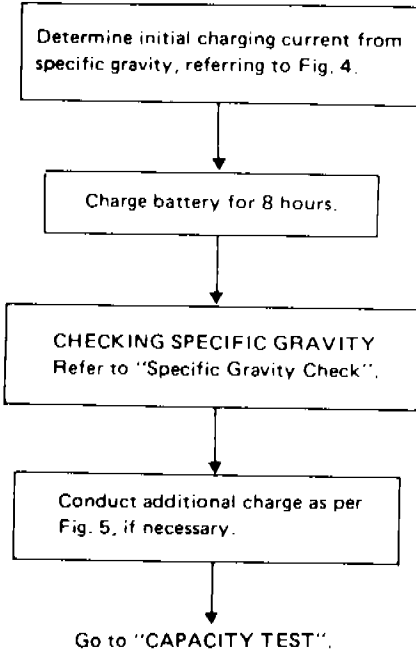
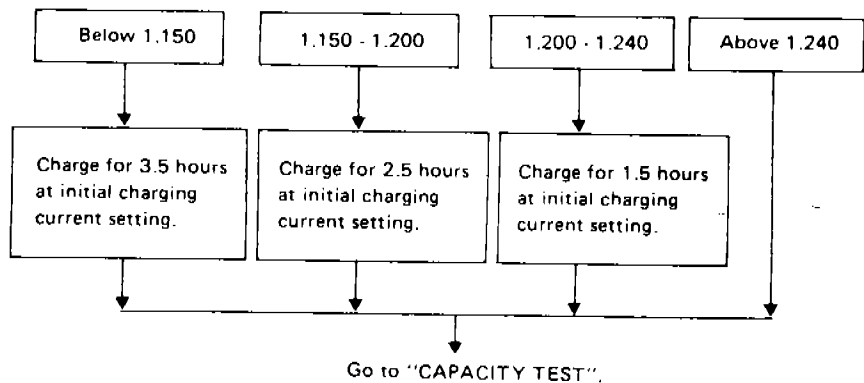

Fig. 4 INITIAL CHARGING CURRENT SETTING
(Standard charge)

| BATTERY TYPE CON- VERTED SPECIFIC GRAVITY | 28B19R(L) 34B19R(L) | | 46B24R(L) 55B24R(L) | | 50D23R(L) 55D23R(L) | | 65D26R(L) 80D26R(L) | | 75D31R(L) | 95D31R(L) 95E41R(L) | | 130E41R(L) |
|-------------------------------------------------------|------------------------|---------|------------------------|---------|------------------------|---------|------------------------|----------|-----------|------------------------|--|------------|
| | 1.100 - 1.130 | 4.0 (A) | 5.0 (A) | 6.0 (A) | 7.0 (A) | 8.0 (A) | 9.0 (A) | 13.0 (A) | | | | |
| 1.130 - 1.160 | 3.0 (A) | 4.0 (A) | 5.0 (A) | 6.0 (A) | 7.0 (A) | 8.0 (A) | 11.0 (A) | | | | | |
| 1.160 - 1.190 | 2.0 (A) | 3.0 (A) | 4.0 (A) | 5.0 (A) | 6.0 (A) | 7.0 (A) | 9.0 (A) | | | | | |
| 1.190 - 1.220 | 2.0 (A) | 2.0 (A) | 3.0 (A) | 4.0 (A) | 5.0 (A) | 5.0 (A) | 7.0 (A) | | | | | |

- Check battery type and determine the specified current using the table shown above.
- After starting charging, adjustment of charging current is not necessary.

Fig. 5 ADDITIONAL CHARGE (Standard charge)



CAUTION:

- Do not use standard charge method on a battery whose specific gravity is less than 1.100.
- Set charging current to value specified in Fig. 4. If charger is not capable of producing specified current value, set its charging current as close to that value as possible.
- Keep battery away from open flame while it is being charged.
- When connecting charger, connect leads first, then turn on charger. Do not turn on charger first, as this may cause a spark.
- If battery temperature rises above 60°C (140°F), stop charging. Always charge battery when its temperature is below 60°C (140°F).

BATTERY

Battery Test and Charging Chart (Cont'd)

C: QUICK CHARGE

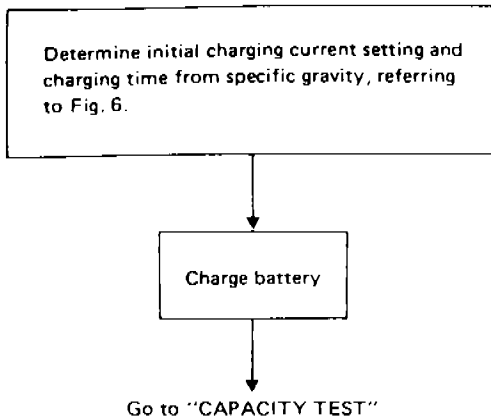

Fig. 6 INITIAL CHARGING CURRENT SETTING AND CHARGING TIME (Quick charge)

| CON- VERTED SPECIFIC GRAVITY | BATTERY TYPE | | CUR- RENT [A] | 28B19R(L) 34B19R(L) | 46B24R(L) 55B24R(L) 50D23R(L) | 55D23R(L) 65D26R(L) 80D26R(L) | 75D31R(L) 95D31R(L) 95E41R(L) | 130E41R(L) |
|---------------------------------------|----------------------|--|---------------------|------------------------|-------------------------------------|-------------------------------------|-------------------------------------|------------|
| | CUR- RENT [A] | | | | | | | |
| | 10 (A) | | 15 (A) | 20 (A) | 30 (A) | 40 (A) | | |
| 1.100 - 1.130 | 2.5 hours | | | | | | | |
| 1.130 - 1.160 | 2.0 hours | | | | | | | |
| 1.160 - 1.190 | 1.5 hours | | | | | | | |
| 1.190 - 1.220 | 1.0 hours | | | | | | | |
| Above 1.220 | 0.75 hours (45 min.) | | | | | | | |

- Check battery type and determine the specified current using the table shown above.
- After starting charging, adjustment of charging current is not necessary.

CAUTION:

- Do not use quick charge method on a battery whose specific gravity is less than 1.100.
- Set initial charging current to value specified in Fig. 6. If charger is not capable of producing specified current value, set its charging current as close to that value as possible.
- Keep battery away from open flame while it is being charged.
- When connecting charger, connect leads first, then turn on charger. Do not turn on charger first, as this may cause a spark.
- Be careful of a rise in battery temperature because a large current flow is required during quick-charge operation.
If battery temperature rises above 60°C (140°F), stop charging. Always charge battery when its temperature is below 60°C (140°F).
- Do not exceed the charging time specified in Fig. 6, because charging battery over the charging time can cause deterioration of the battery.

Service Data and Specifications (S.D.S.)

| Applied area | Europe | Except Europe (Option) | Except Europe |
|--------------|--------|------------------------|---------------|
| Type | 55D23R | | 34B19R |
| Capacity | V-AH | 12-60 | 12-33 |

STARTING SYSTEM

Wiring Diagram

M/T MODEL

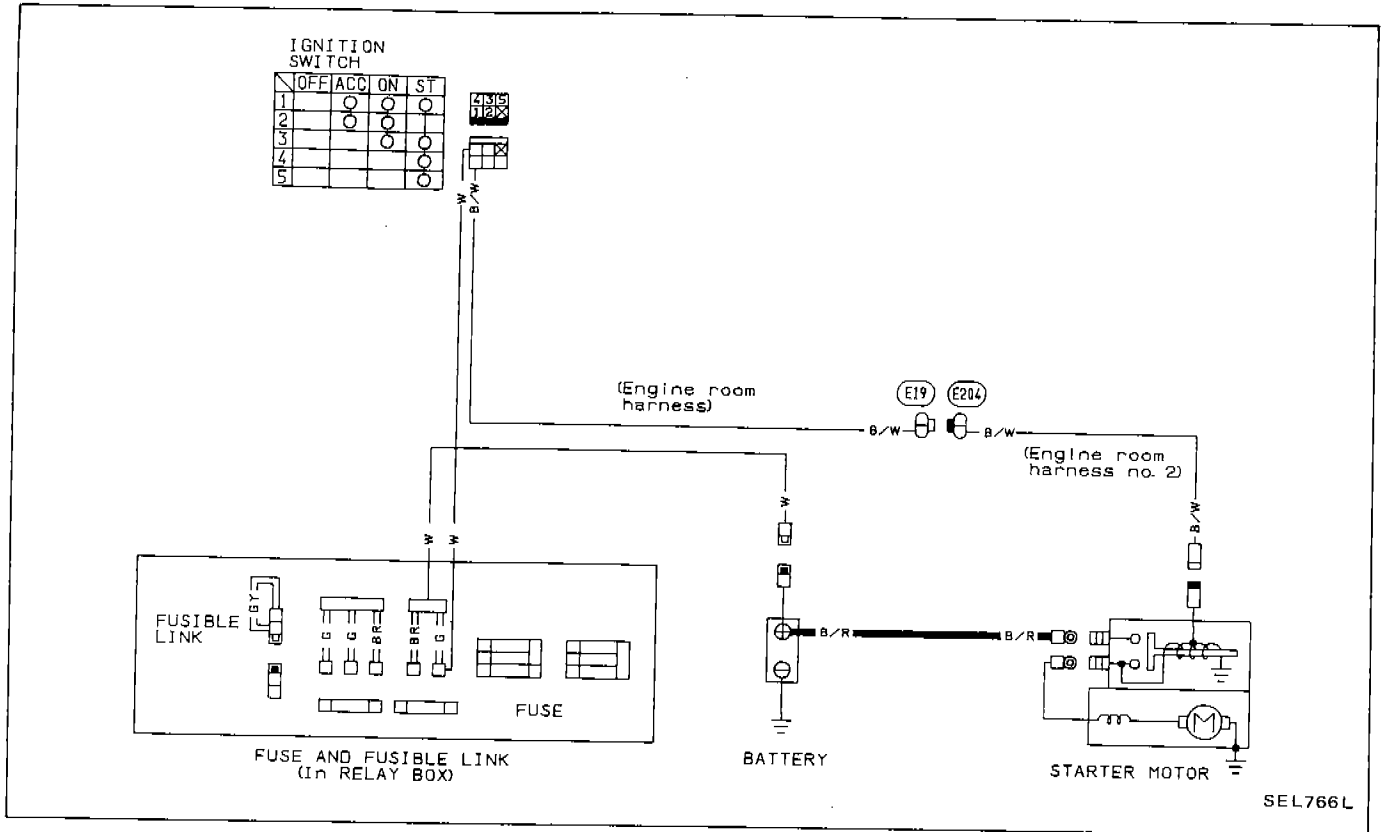

A/T MODEL

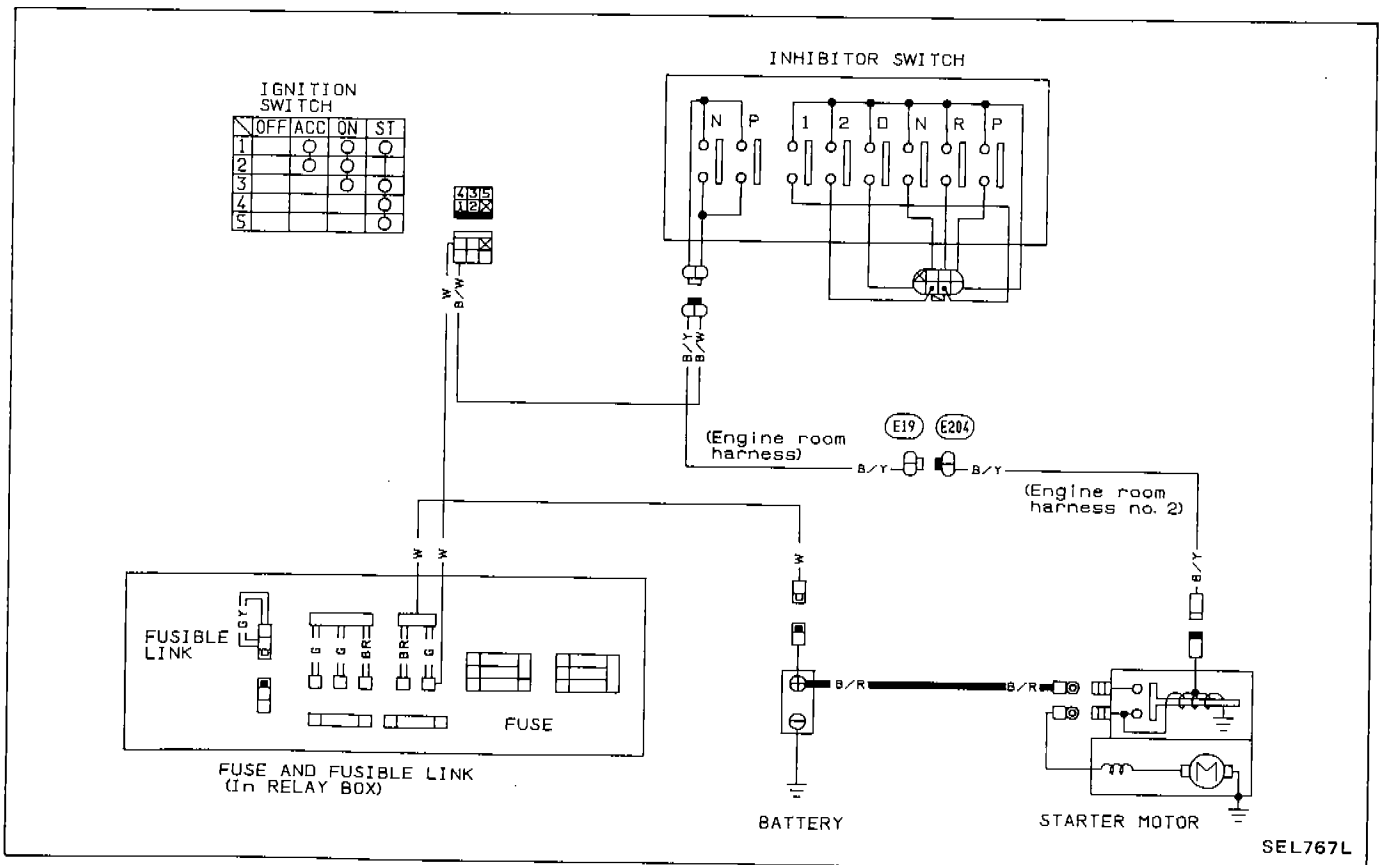

STARTING SYSTEM

Trouble-shooting

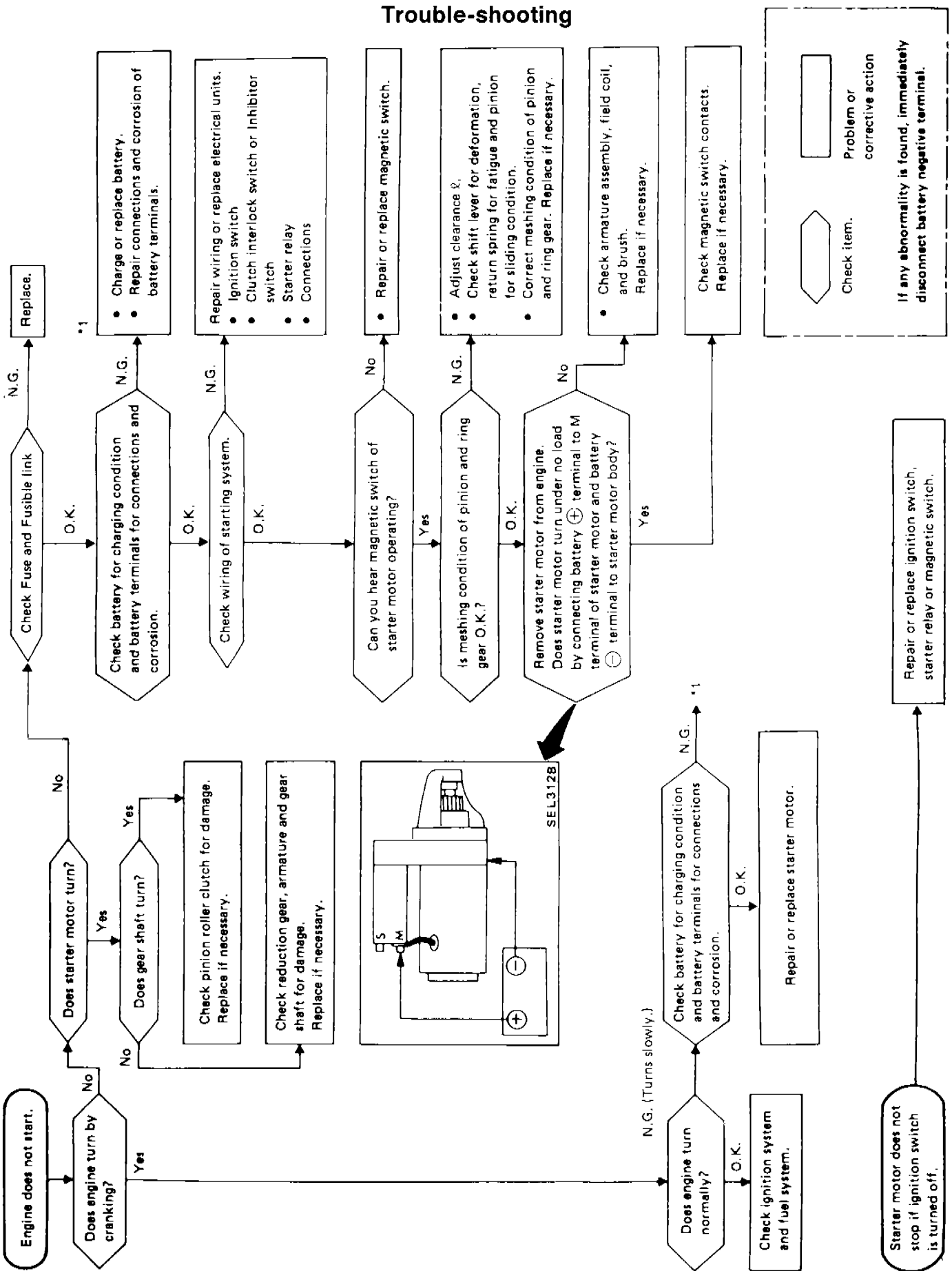

Construction

S114-523

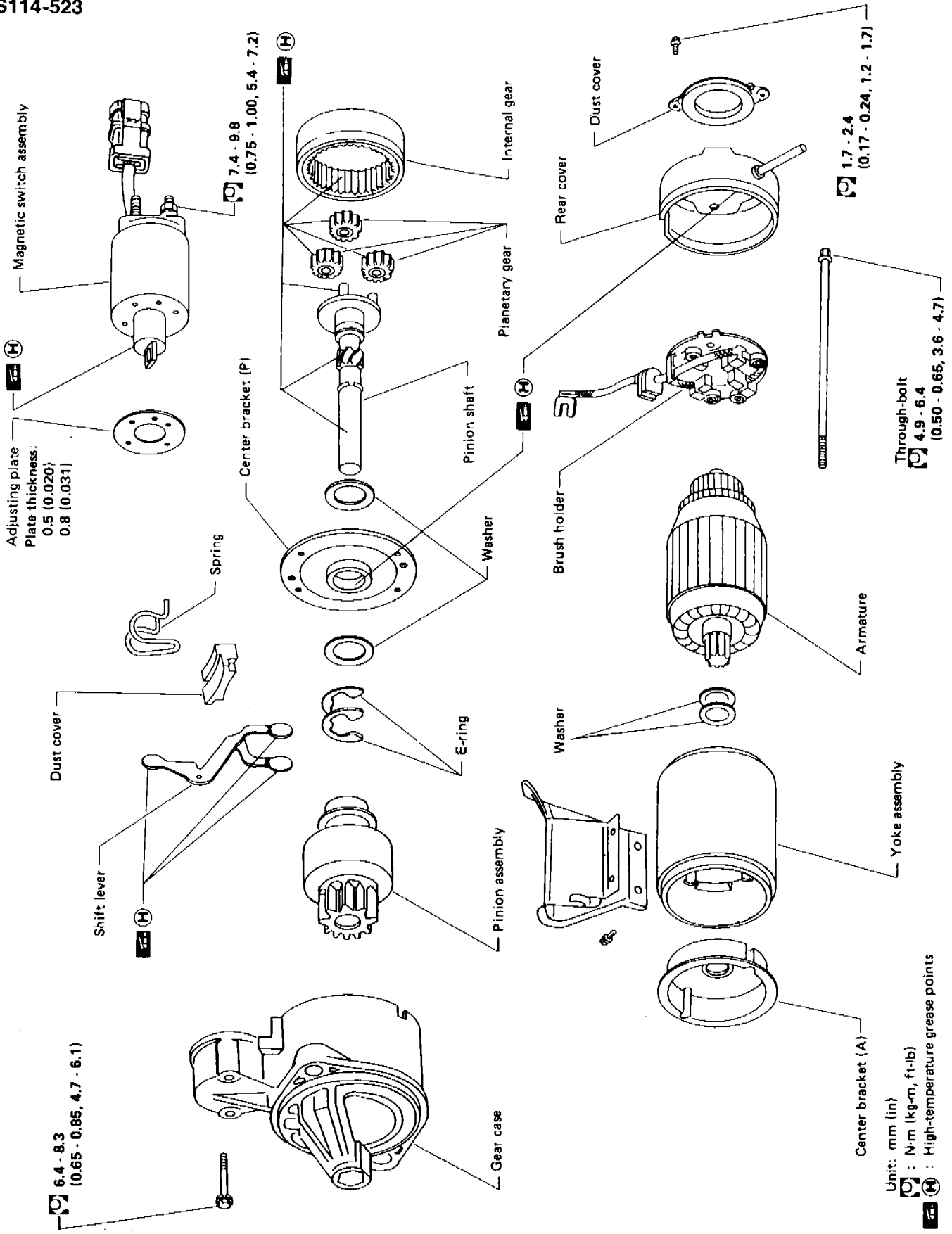

Unit: mm (in)
 : N·m (kg·m, ft·lb)
 : High-temperature grease points

SEL647J

STARTING SYSTEM — Starter —

Construction (Cont'd)

M1T71481

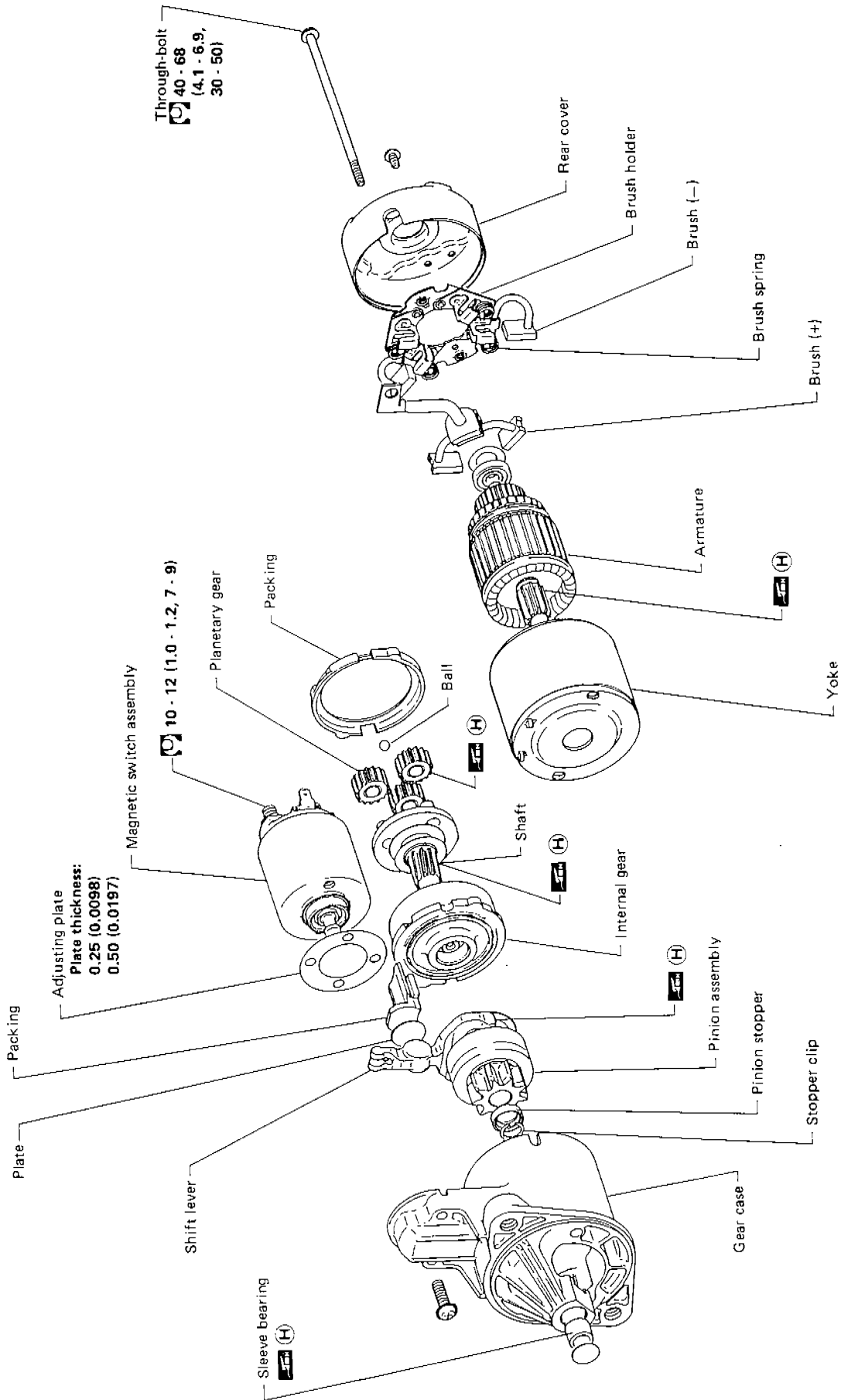

EL-20

Unit : mm (in)
 : N-m (kg-m, ft-lb)
 : High-temperature grease point

SEL707L

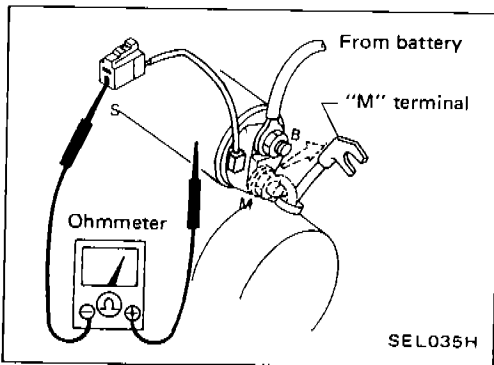

Magnetic Switch Check

- Before starting to check, disconnect battery ground cable.
 - Disconnect "M" terminal of starter motor.
1. Continuity test (between "S" terminal and switch body).
 - No continuity ... Replace.

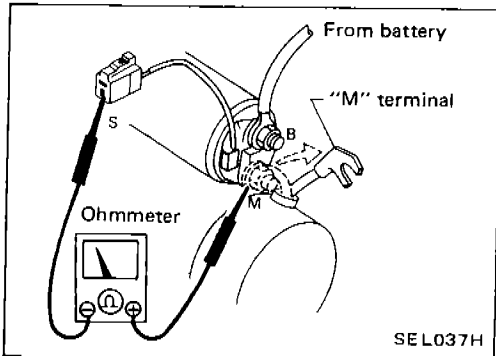

2. Continuity test (between "S" terminal and "M" terminal).
- No continuity ... Replace.

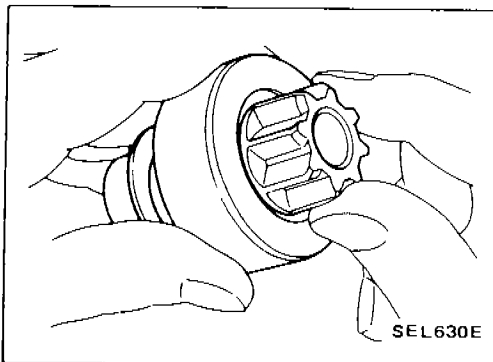

Pinion/Clutch Check

1. Inspect pinion teeth.
 - Replace pinion if teeth are worn or damaged. (Also check condition of ring gear teeth.)
2. Check to see if pinion locks in one direction and rotates smoothly in the opposite direction.
 - If it does not lock (or locks) in either direction or unusual resistance is evident. ... Replace.

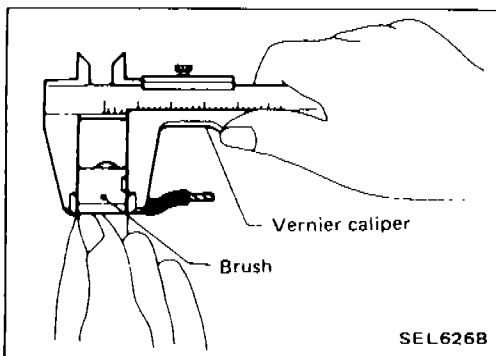

Brush Check

BRUSH

Check wear of brush.

Wear limit length:

Refer to S.D.S.

- Excessive wear ... Replace.

Brush Check (Cont'd)

BRUSH HOLDER

1. Perform insulation test between brush holder (positive side) and its base (negative side).
 - Continuity exists. ... Replace.
2. Check brush to see if it moves smoothly.
 - If brush holder is bent, replace it; if sliding surface is dirty, clean.

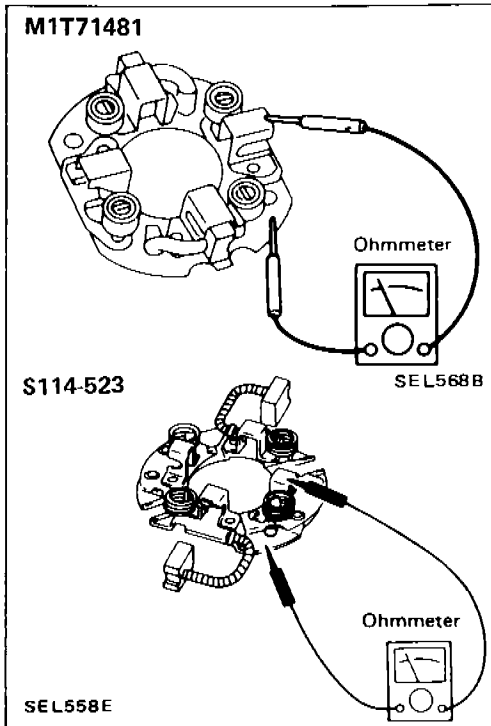

Pole Piece Check

Pole piece is secured to yoke by bonding agent. Check pole piece to see that it is secured to yoke and for any cracks. Replace malfunctioning parts as an assembly. Holder may move slightly as it is only inserted and not bonded.

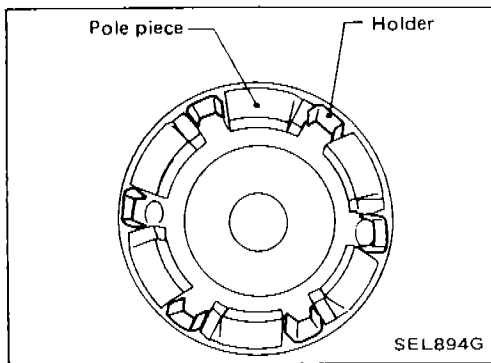

Armature Check

1. Continuity test (between two segments side by side).
 - No continuity ... Replace.

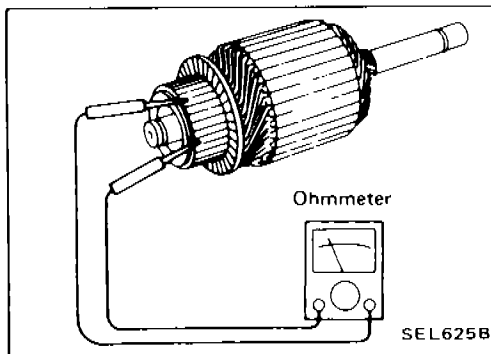

2. Insulation test (between each commutator bar and shaft).
 - Continuity exists. ... Replace.

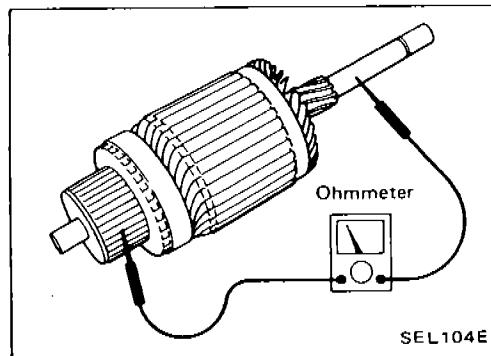

Armature Check (Cont'd)

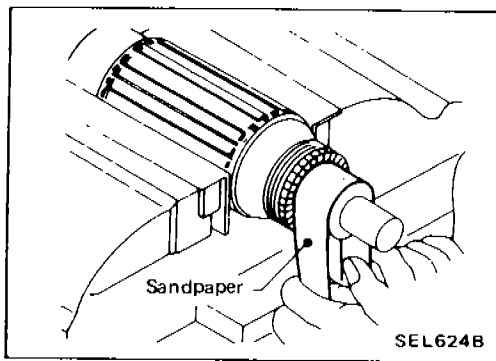

3. Check commutator surface.
 - Rough ... Sand lightly with No. 500 to 600 sandpaper.

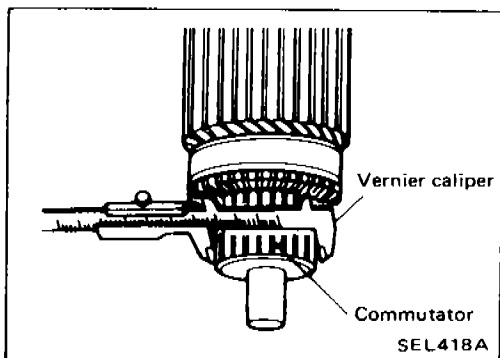

4. Check diameter of commutator.

Commutator minimum diameter:
Refer to S.D.S.

 - Less than specified value ... Replace.

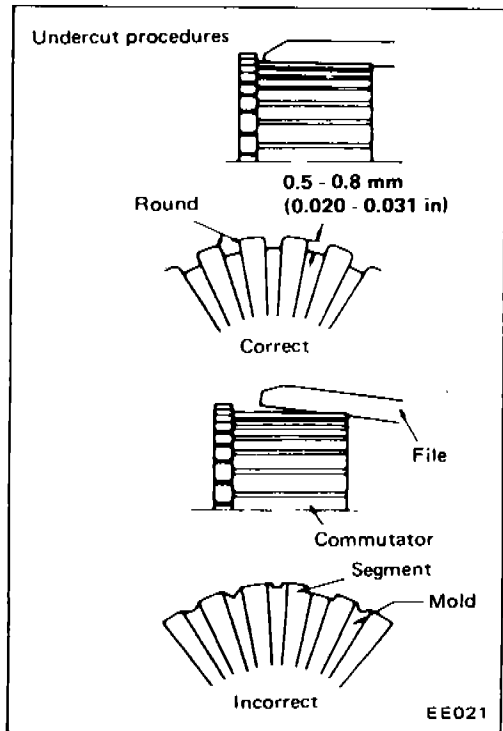

5. Check depth of insulating mold from commutator surface.
 - Less than 0.2 mm (0.008 in) ... Undercut to 0.5 to 0.8 mm (0.020 to 0.031 in)

Assembly

Apply high-temperature grease to lubricate the bearing, gears and frictional surface when assembling the starter.

Carefully observe the following instructions.

- Gear case metal
- Moving portion of shift lever
- Plunger of magnetic switch
- Internal gear
- Planetary gear
- Shaft

Assembly (Cont'd)

PINION PROTRUSION LENGTH ADJUSTMENT

With pinion driven out by magnetic switch, push pinion back to remove slack and measure clearance "ℓ" between the front edge of the pinion and the pinion stopper.

Clearance "ℓ":
Refer to S.D.S.

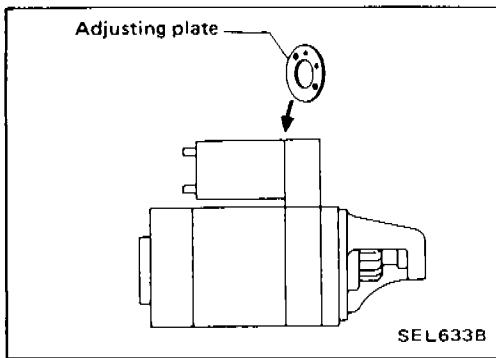
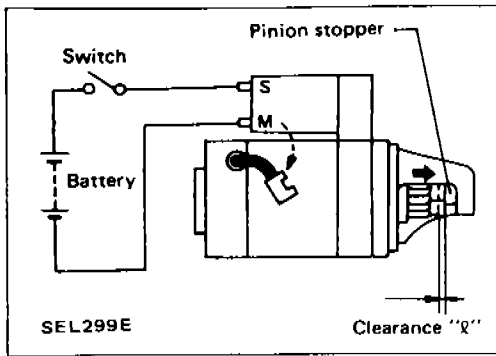

- Not in the specified value ... Adjust by adjusting plate.

Service Data and Specifications (S.D.S.)

STARTER

| Type | S114-523 | | M1T71481 | |
|------------------------------------------------------------|--------------|---------------------------------------|---------------------------------------|--|
| | HITACHI make | | MITSUBISHI make | |
| Reduction gear type | | | | |
| Applied model | All | | | |
| System voltage | V | 12 | | |
| No-load | | | | |
| Terminal voltage | V | 11.0 | | |
| Current | A | Less than 90 | 50 - 75 | |
| Revolution | rpm | More than 2,950 | 3,000 - 4,000 | |
| Minimum diameter of commutator | mm (in) | 32.0 (1.260) | 28.8 (1.134) | |
| Minimum length of brush | mm (in) | 11.0 (0.433) | 12.0 (0.472) | |
| Brush spring tension | N (kg, lb) | 17.7 - 21.6 (1.8 - 2.2, 4.0 - 4.9) | 13.7 - 25.5 (1.4 - 2.6, 3.1 - 5.7) | |
| Clearance of bearing metal and armature shaft | mm (in) | 0.2 (0.008) | — | |
| Clearance "ℓ" between pinion front edge and pinion stopper | mm (in) | 0.3 - 1.5 (0.012 - 0.059) | 0.5 - 2.0 (0.020 - 0.079) | |

CHARGING SYSTEM

Trouble-shooting

Before conducting an alternator test, make sure that the battery is fully charged. A 30-volt voltmeter and suitable test probes are necessary for the test. The alternator can be checked easily by referring to the Inspection Table.

Before starting trouble-shooting, inspect the fusible link.

WITH IC REGULATOR

With alternator side L terminal grounded, internal short occurs if + diode is short-circuited.

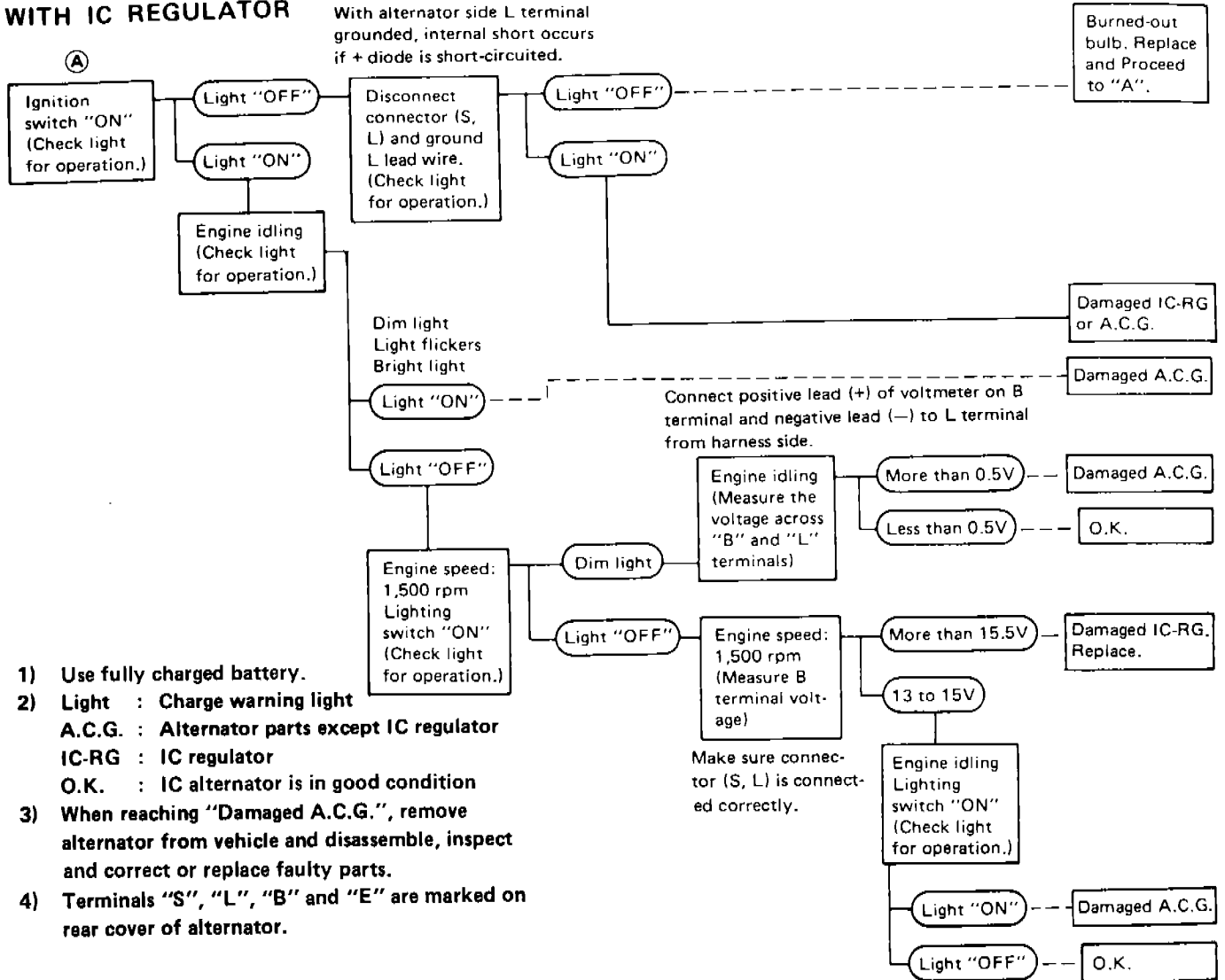

- 1) Use fully charged battery.
- 2) Light : Charge warning light
A.C.G. : Alternator parts except IC regulator
IC-RG : IC regulator
O.K. : IC alternator is in good condition
- 3) When reaching "Damaged A.C.G.", remove alternator from vehicle and disassemble, inspect and correct or replace faulty parts.
- 4) Terminals "S", "L", "B" and "E" are marked on rear cover of alternator.

Construction

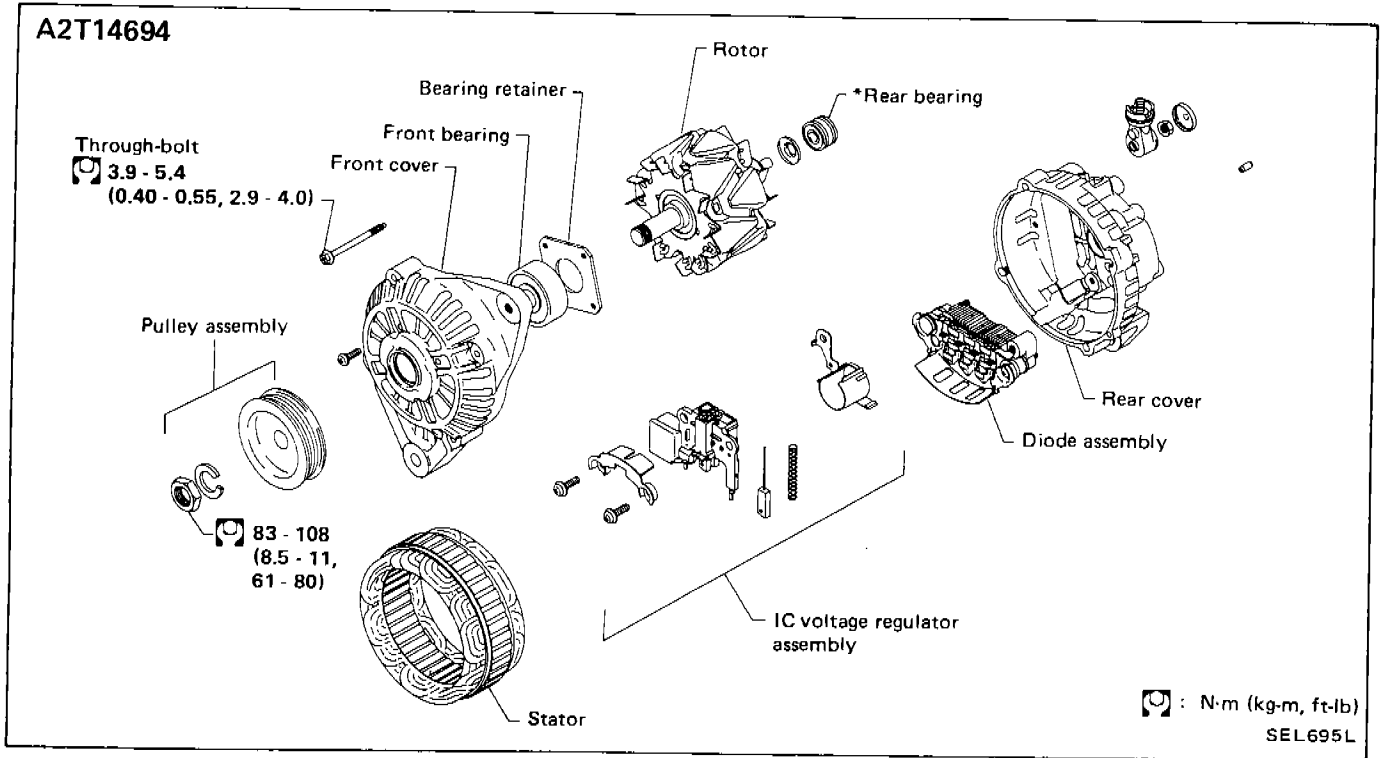

*Rear bearing

CAUTION:

Rear cover may be hard to remove because a ring is used to lock outer race of rear bearing. Be careful not to lose this ring during removal.

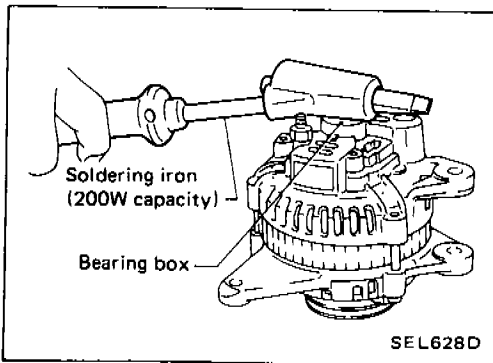

Disassembly

REAR COVER REMOVAL

CAUTION:

To facilitate removal of rear cover, heat just bearing box section with a 200W soldering iron. Do not use a heat gun, as it can damage diode assembly.

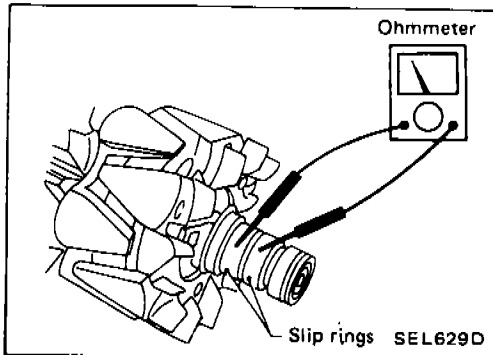

Rotor Slip Ring Check

1. Continuity test
- No continuity ... Replace rotor.

Rotor Slip Ring Check (Cont'd)

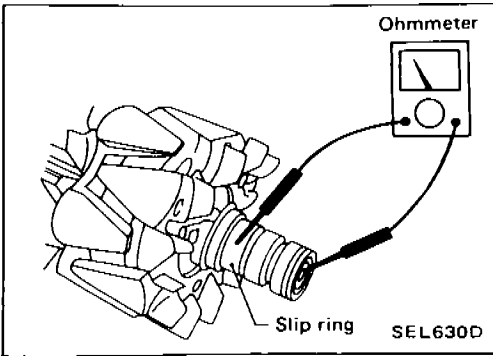

2. Insulator test
 - Continuity exists. ... Replace rotor.
3. Check slip ring for wear.

Slip ring minimum outer diameter:
Refer to S.D.S.

Brush Check

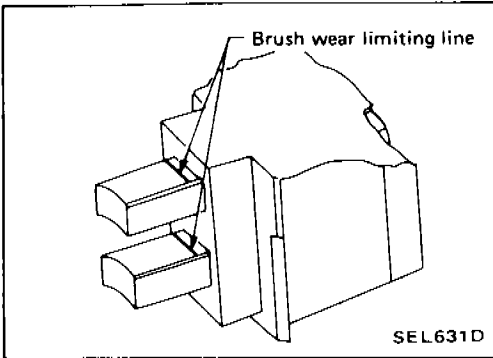

1. Check smooth movement of brush.
 - Not smooth ... Check brush holder and clean.
2. Check brush for wear.
 - Replace brush if it is worn down to the limit line.

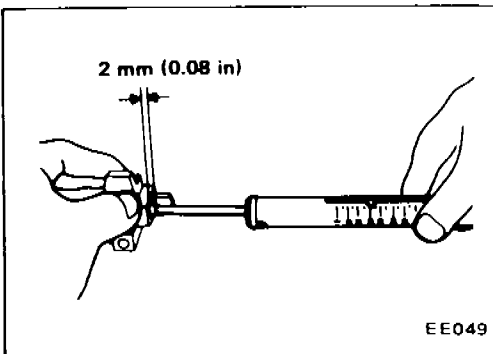

3. Check brush lead wire for damage.
 - Damaged ... Replace.
4. Check brush spring pressure.

Measure brush spring pressure with brush projected approximately 2 mm (0.08 in) from brush holder.

Spring pressure:
Refer to S.D.S.

 - Not within the specified values ... Replace.

Stator Check

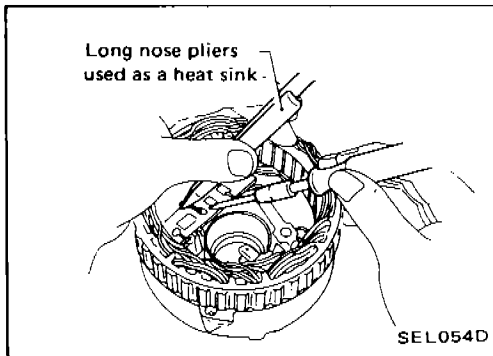

To test the stator or diode, separate them by unsoldering the connecting wires.

CAUTION:

Use only as much heat as required to melt solder. Otherwise, diodes will be damaged by excessive heat.

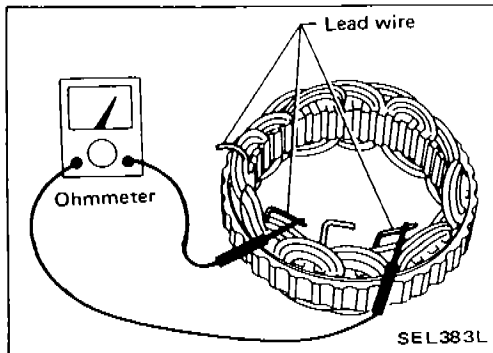

1. Continuity test
 - No continuity ... Replace stator.

Stator Check (Cont'd)

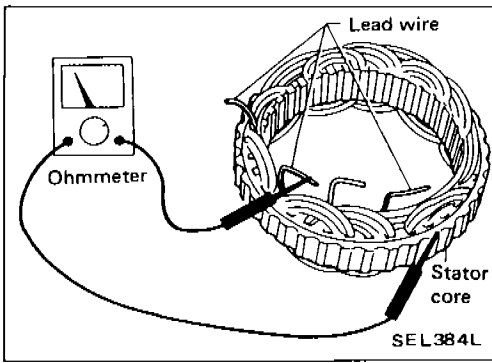

2. Ground test
 - Continuity exists. ... Replace stator.

Diode Check

MAIN DIODES

- Use an ohmmeter to check condition of diodes as indicated in chart below:
- If any of the test results is not satisfactory, replace diode assembly.

| | Ohmmeter probes | | Continuity |
|------------------------------|----------------------|----------------------|------------|
| | Positive ⊕ | Negative ⊖ | |
| Diodes check (Positive side) | Positive diode plate | Diode terminals | Yes |
| | Diode terminals | Positive diode plate | No |
| Diodes check (Negative side) | Negative diode plate | Diode terminals | No |
| | Diode terminals | Negative diode plate | Yes |

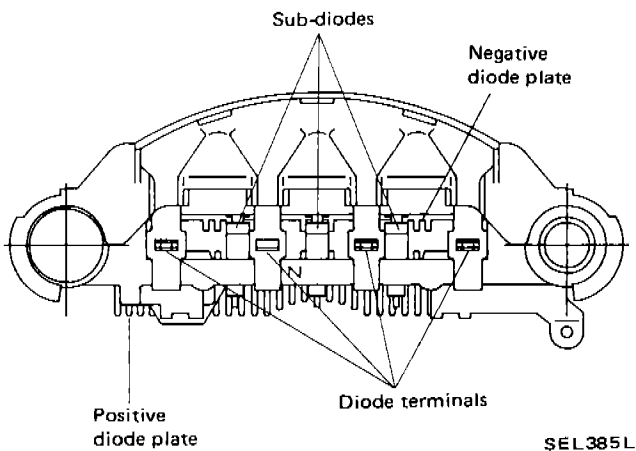

SEL385L

SUB-DIODES

- Attach ohmmeter's probe to each end of diode to check for continuity.
- Continuity is N.G. ... Replace diode assembly.

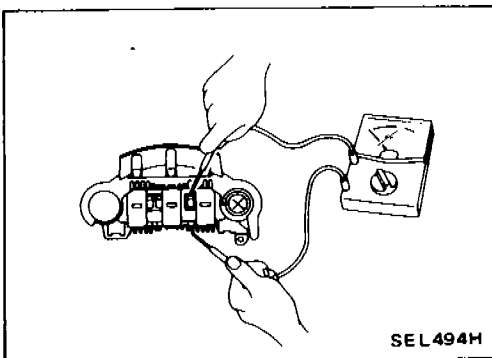

SEL494H

Assembly

Carefully observe the following instructions.

- When soldering each stator coil lead wire to diode assembly terminal, carry out the operation as fast as possible.

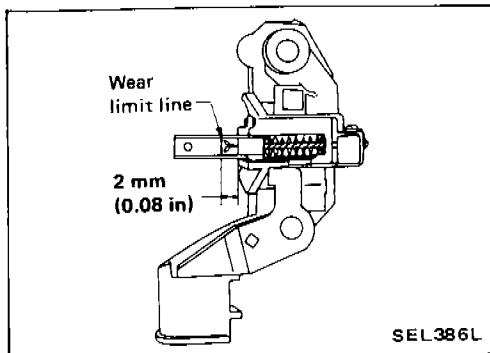

WHEN SOLDERING BRUSH LEAD WIRE

- Position brush so that its wear limit line protrudes 2 mm (0.08 in) beyond end face of brush holder.

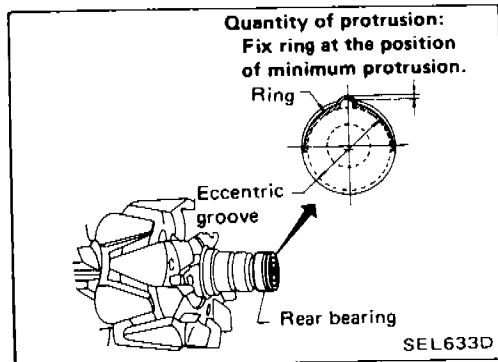

RING FITTING IN REAR BEARING

- Fix ring into groove in rear bearing so that it is as close to the adjacent area as possible.

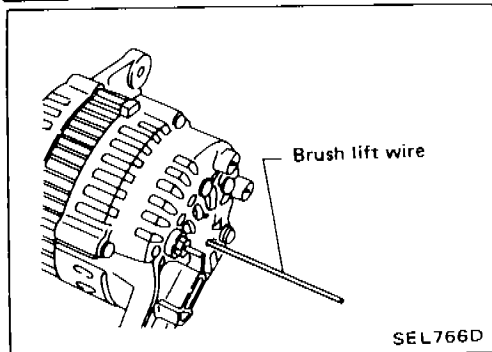

REAR COVER INSTALLATION

- (1) Before installing front cover with pulley and rotor with rear cover, push brush up with fingers and retain brush by inserting brush lift wire into brush lift hole from outside.
- (2) After installing front and rear sides of alternator, pull brush lift wire by pushing toward the center.

Do not pull brush lift wire by pushing toward outside of rear cover as it will damage slip ring sliding surface.

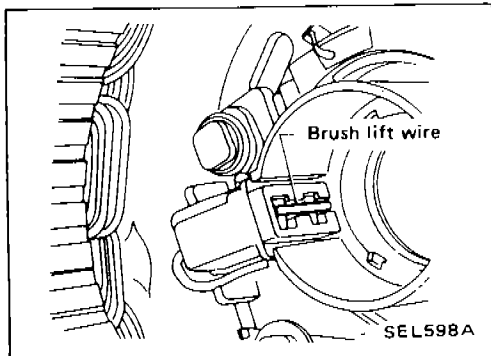

CHARGING SYSTEM — Alternator —

Service Data and Specifications (S.D.S.) ALTERNATOR

| | | |
|------------------------------------------------------------------|-----------|---------------------------------------------|
| Type | | A2T14694 |
| Applied model | | All |
| Nominal rating | V-A | 12-80 |
| Ground polarity | | Negative |
| Minimum revolution under no-load (When 13.5 volts is applied) | rpm | Less than 1,100 |
| Hot output current | A/rpm | More than 22/1,300 More than 60/2,500 |
| Regulated output voltage | V | 14.1 - 14.7 |
| Minimum length of brush | mm (in) | 8.0 (0.315) |
| Brush spring pressure | N (g, oz) | 3.040 - 4.217 (310 - 430, 10.93 - 15.17) |
| Slip ring minimum outer diameter | mm (in) | 22.1 (0.870) |

COMBINATION SWITCH

Check

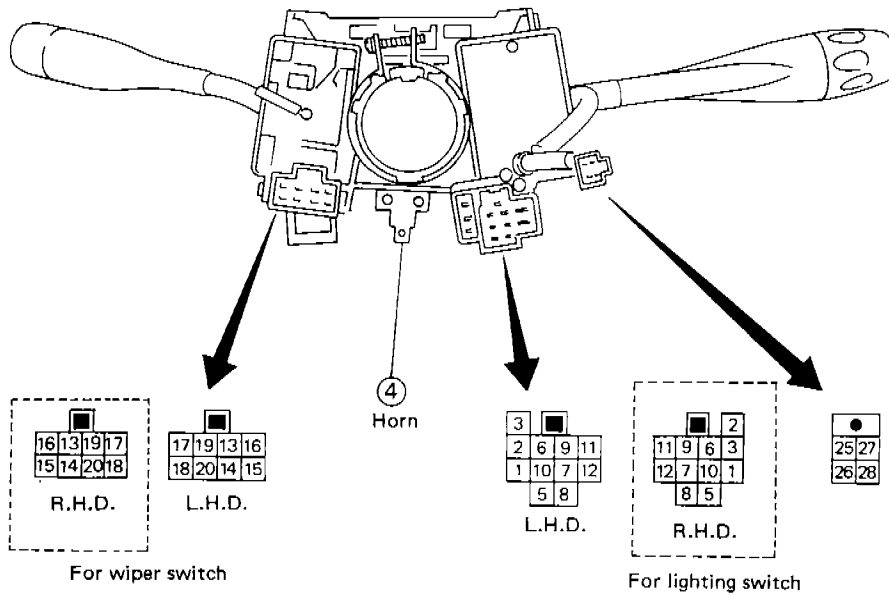
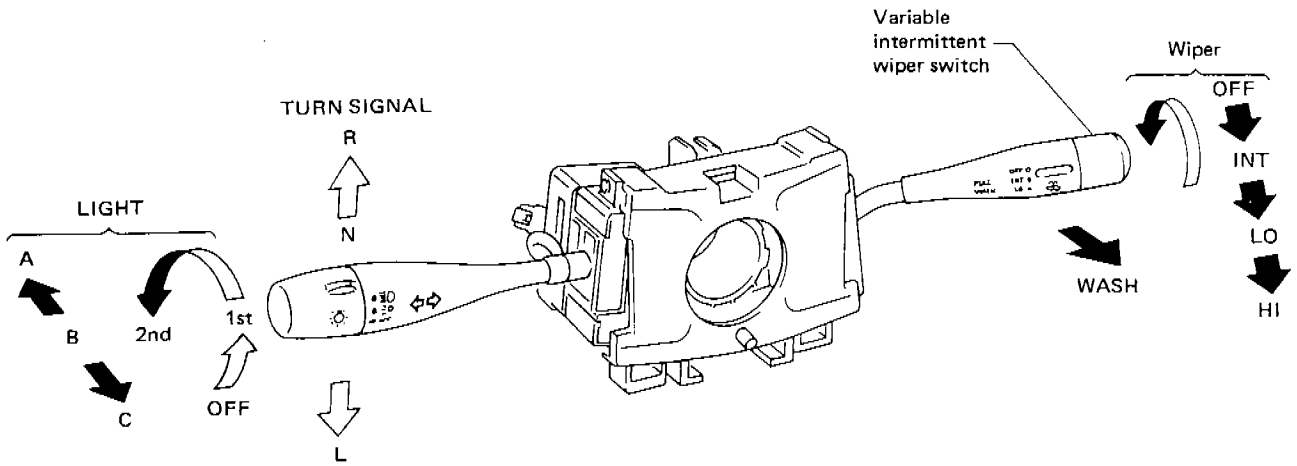

LIGHTING SWITCH

| | OFF | | | 1 | | | 2 | | |
|----|-----|---|---|---|---|---|---|---|---|
| | A | B | C | A | B | C | A | B | C |
| 5 | | | | | | | | | |
| 6 | | | | | | | | | |
| 7 | | | | | | | | | |
| 8 | | | | | | | | | |
| 9 | | | | | | | | | |
| 10 | | | | | | | | | |
| 11 | | | | | | | | | |
| 12 | | | | | | | | | |
| 25 | | | | | | | | | |
| 26 | | | | | | | | | |
| 27 | | | | | | | | | |
| 28 | | | | | | | | | |

WIPER SWITCH

| | OFF | INT | LO | HI | WASH |
|----|-----|-----|----|----|------|
| 13 | | | | | |
| 14 | | | | | |
| 15 | | | | | |
| 16 | | | | | |
| 17 | | | | | |
| 18 | | | | | |

INTERMITTENT WIPER VOLUME

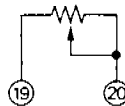

HORN SWITCH

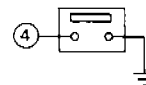

TURN SIGNAL SWITCH

| | R | N | L |
|---|---|---|---|
| 1 | | | |
| 2 | | | |
| 3 | | | |

SEL696L

COMBINATION SWITCH

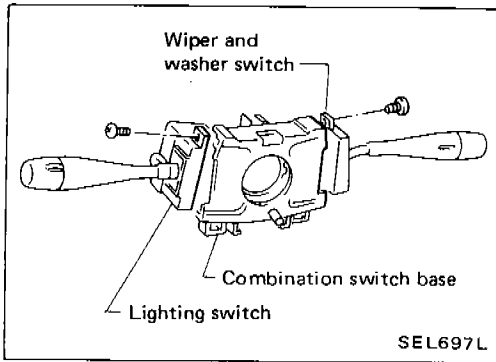

Replacement

- Each switch can be replaced without removing combination switch base.

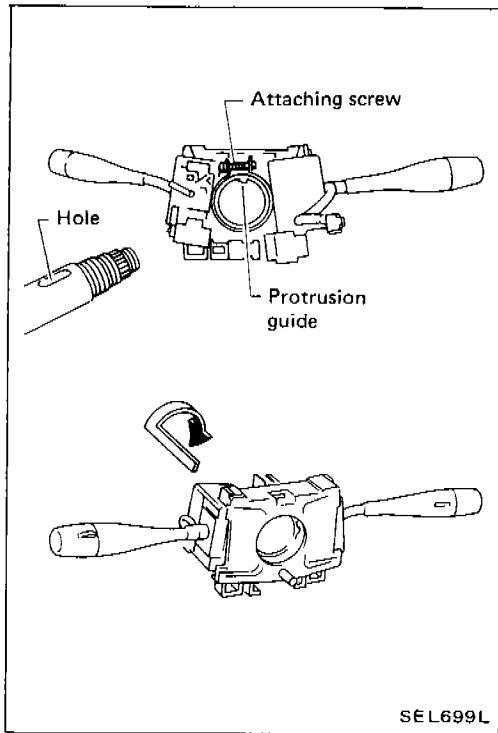

- To remove combination switch base, remove base attaching screw and turn after pushing on it.

HEADLAMP

Schematic

MODEL WITH DIM-DIP
LAMP SYSTEM

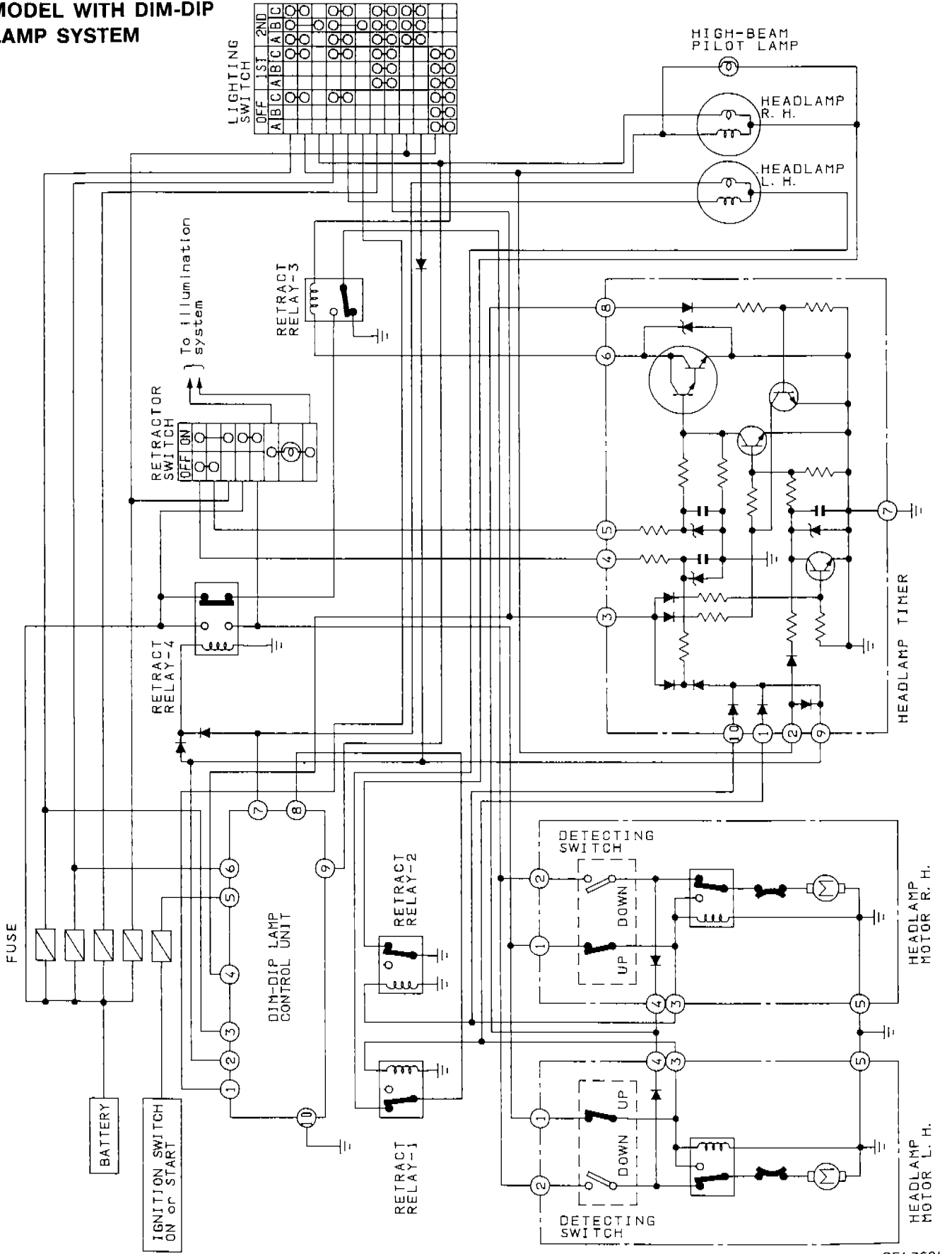

SEL769L

HEADLAMP

Schematic (Cont'd)

MODEL WITHOUT DIM-DIP LAMP SYSTEM

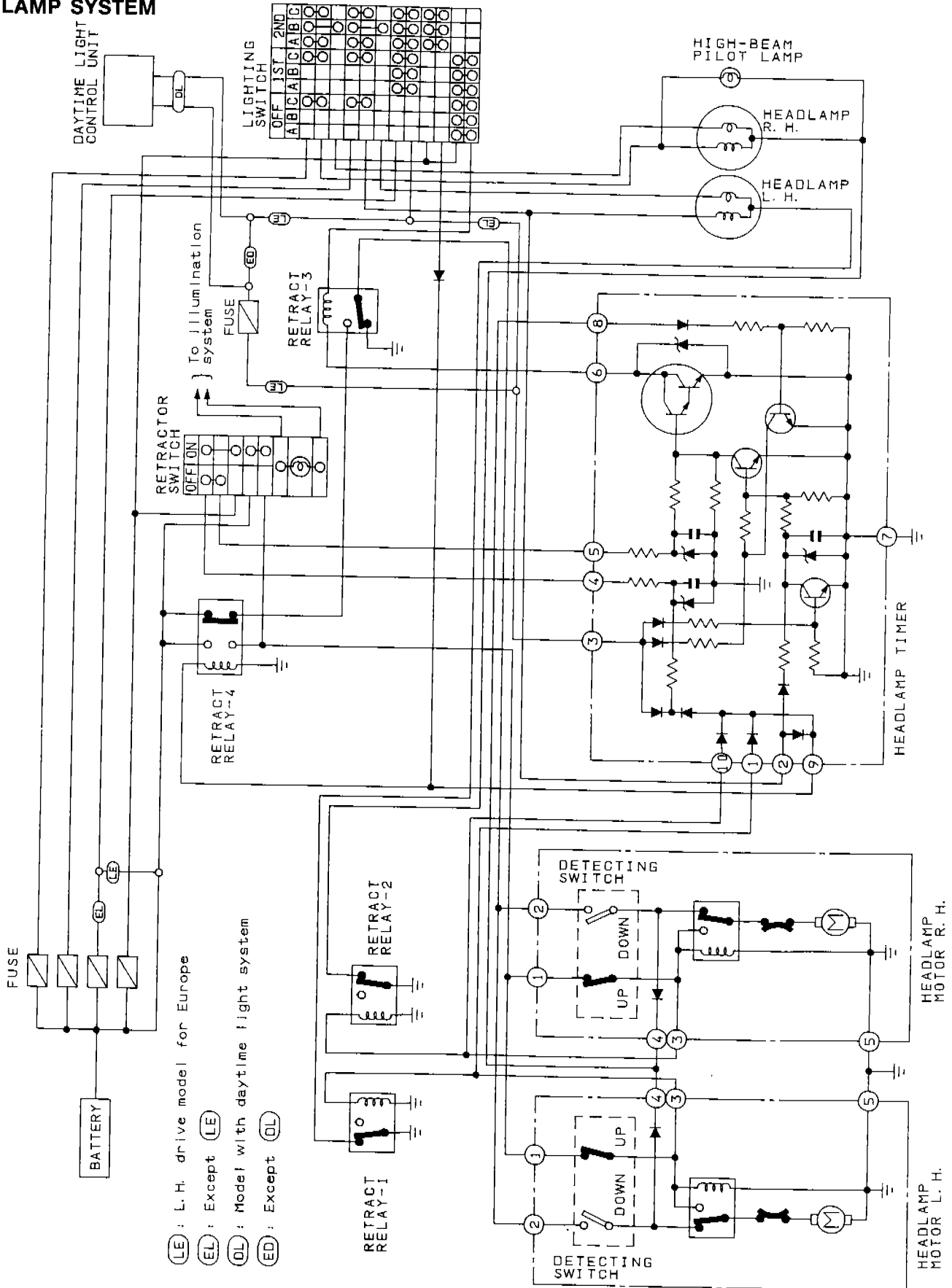

- (LE) : L. H. drive model for Europe
- (EL) : Except (LE)
- (DL) : Model with daytime light system
- (ED) : Except (DL)

SEL770L

HEADLAMP

Description

BASIC OPERATION

| Condition | | Operation | |
|--------------------------------------------------------------|------------------|-------------------------------------------|-----------------------------------------------------------------------------------|
| Lighting switch | Retractor switch | Headlamp motor | Headlamps |
| OFF → 1ST | OFF | No operation | OFF |
| 1ST → 2ND | OFF | Open | ON after headlamp motor reaches fully open position. |
| 2ND → 1ST | OFF | Held to open position | OFF |
| 1ST → OFF | OFF | Closed | OFF |
| Except for Europe model Momentarily turned to PASSING | OFF | Opened and closed after headlamps go off. | Momentarily ON after headlamp motor reaches fully open position, and then go off. |
| For Europe model Momentarily turned to PASSING | OFF | Opened and closed | OFF |
| Held at PASSING position | OFF | Open | ON after headlamp motor reaches fully open position. |
| Release PASSING position | OFF | Closed after headlamps go off. | OFF |
| OFF | ON | Open | OFF |

HEADLAMP

Description (Cont'd)

CIRCUIT OPERATION

[A] When lighting switch is switched from "1ST" → "2ND"

A-1: While operating the headlamp motor to open position

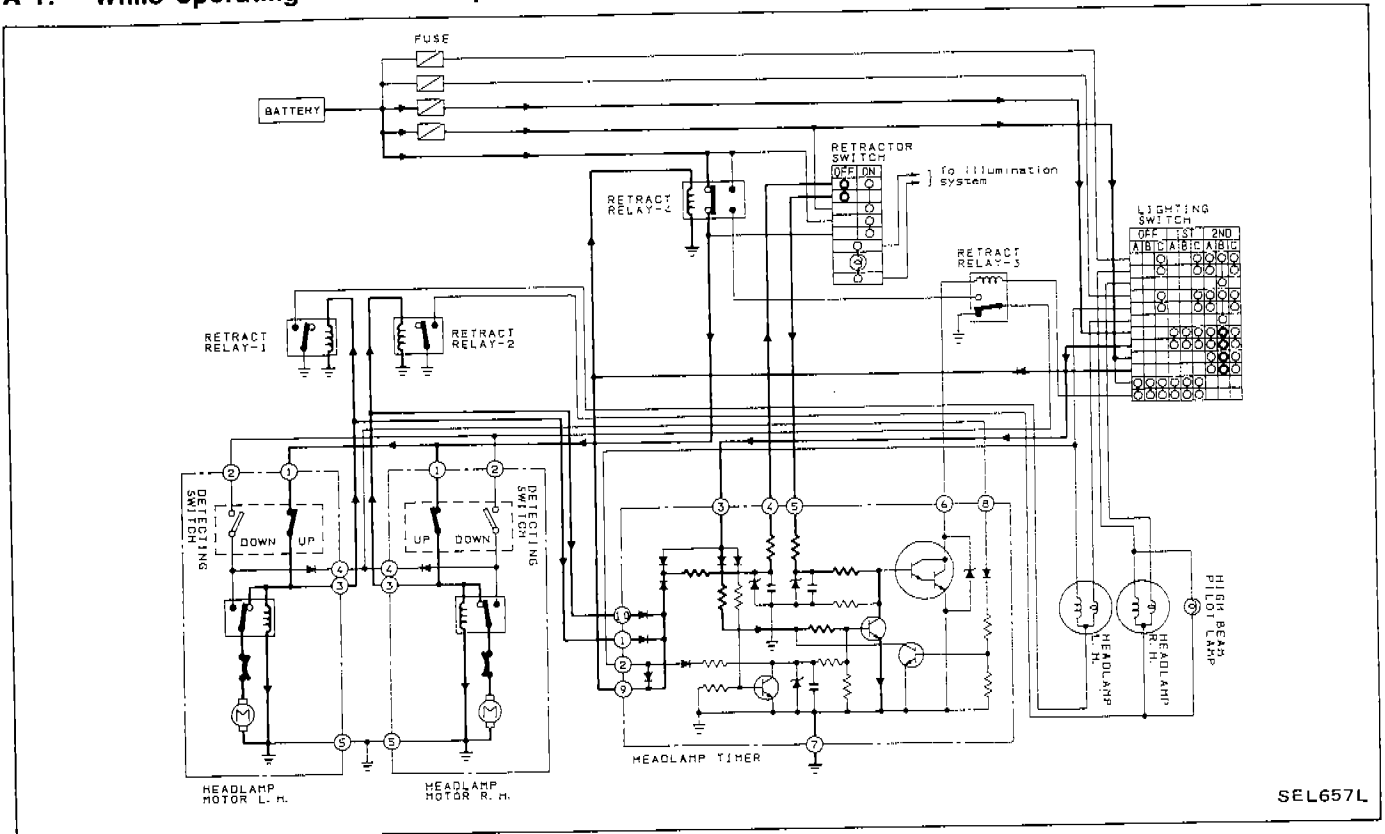

SEL657L

A-2: After the headlamp motor reaches fully open position

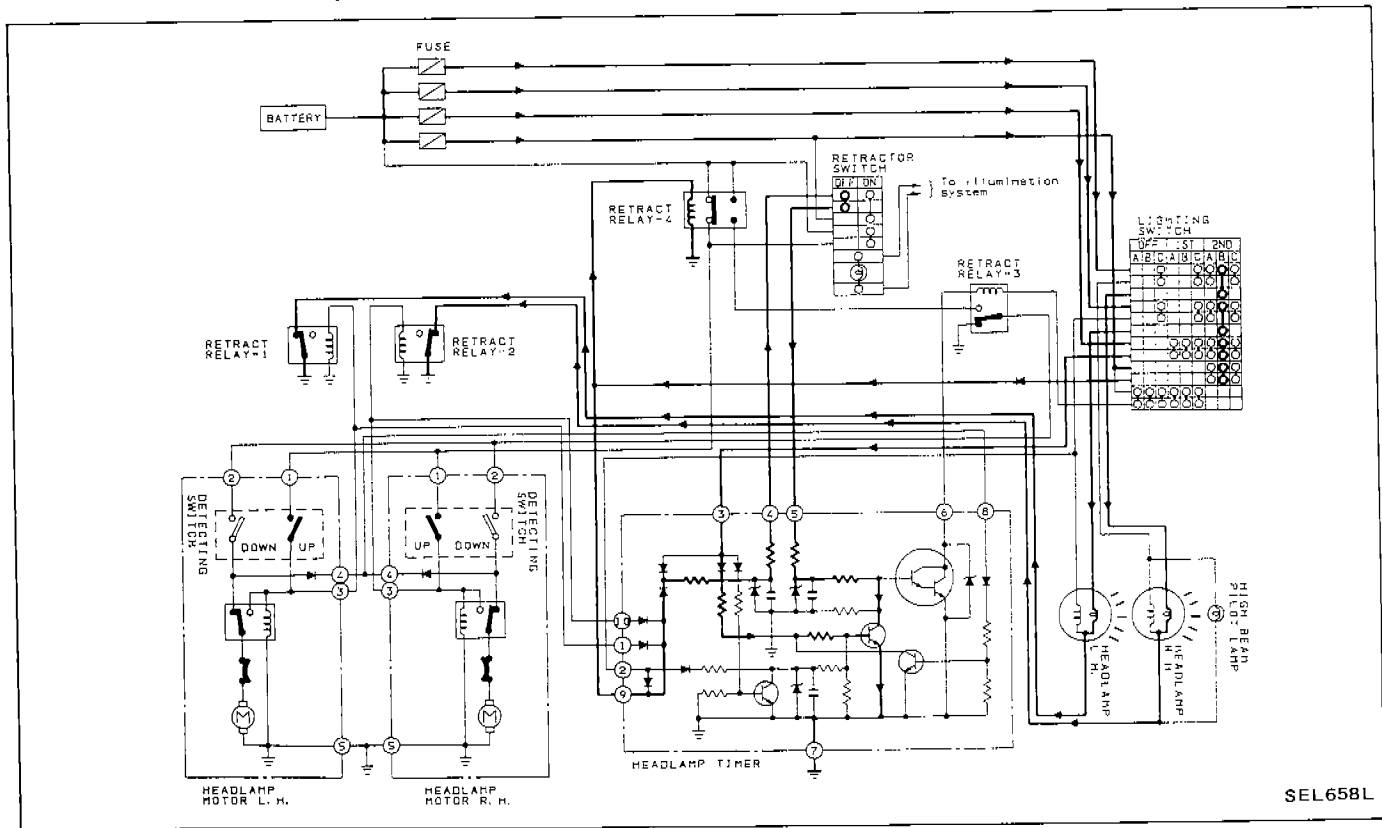

SEL658L

HEADLAMP

Description (Cont'd)

C-2: After the headlamp reaches fully open position

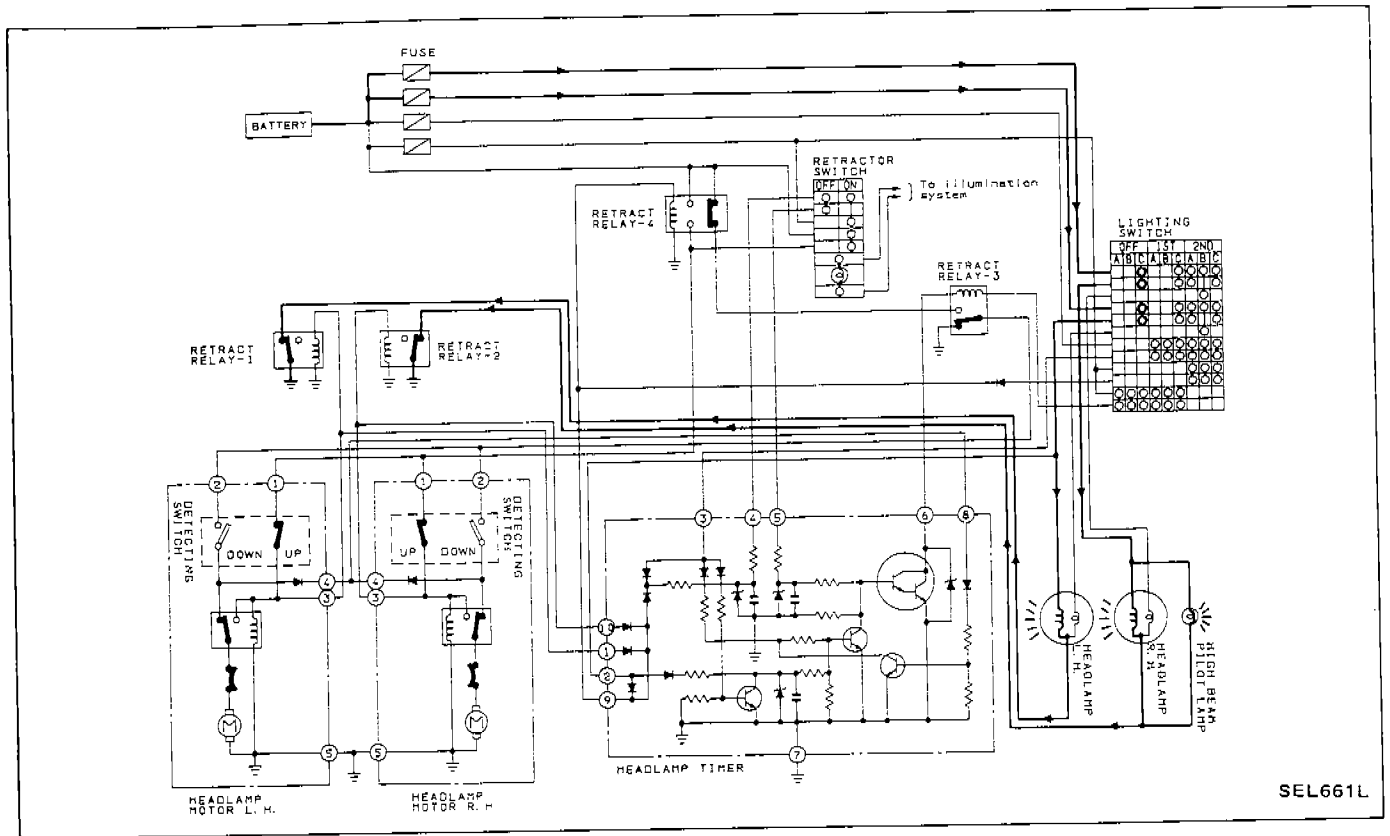

[D] When retractor switch is turned ON (While operating the headlamp motor to open position)

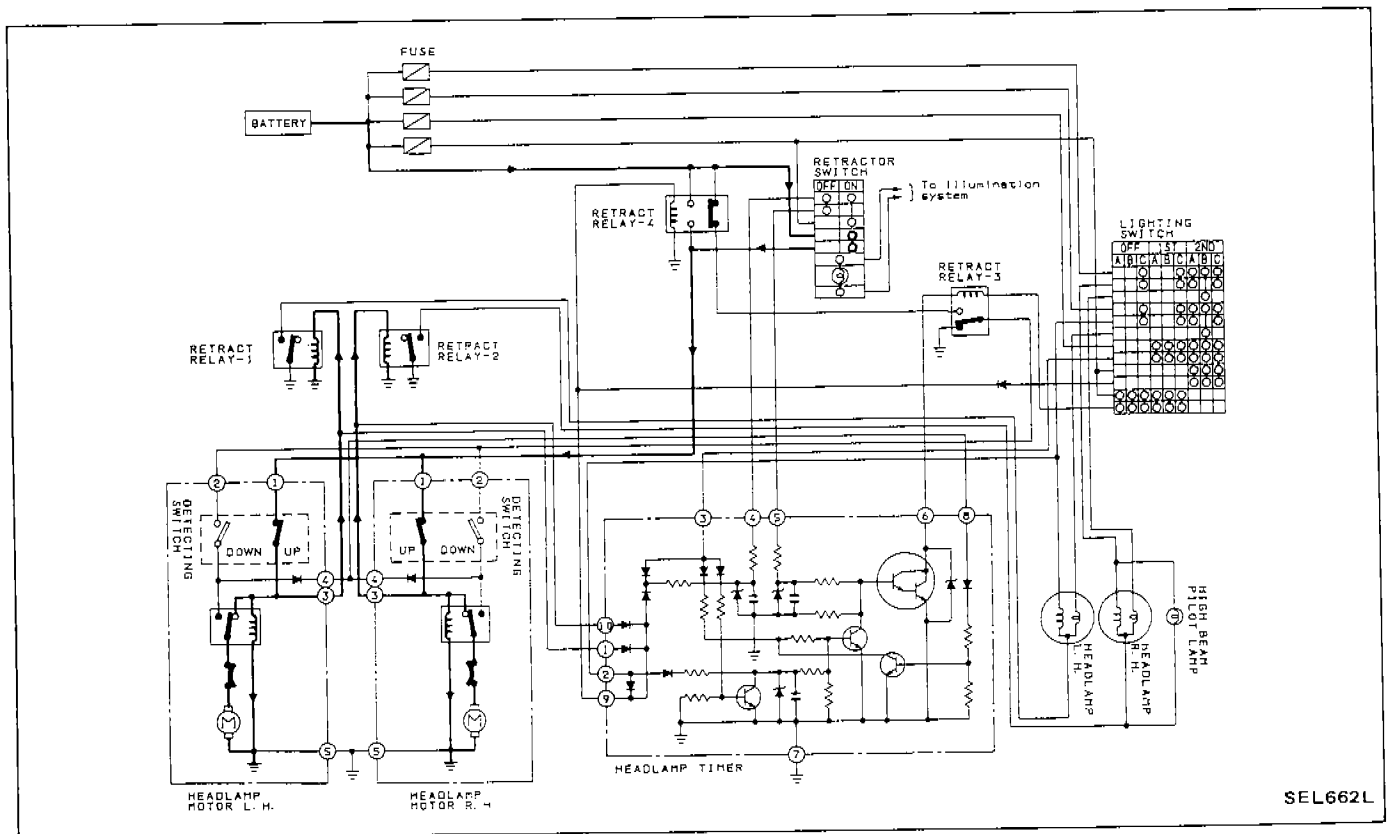

HEADLAMP

Constructions

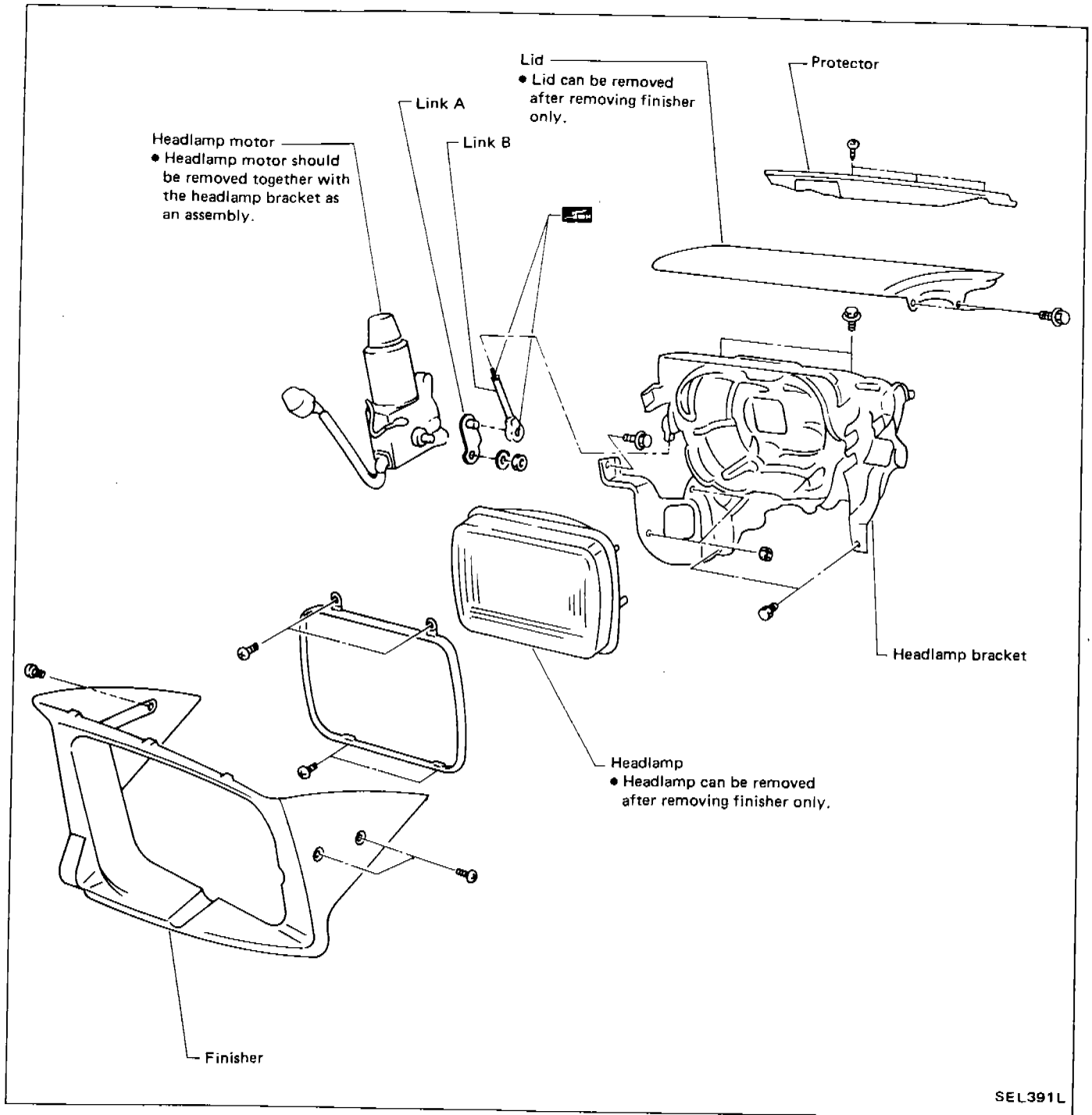

SEL391L

HEADLAMP

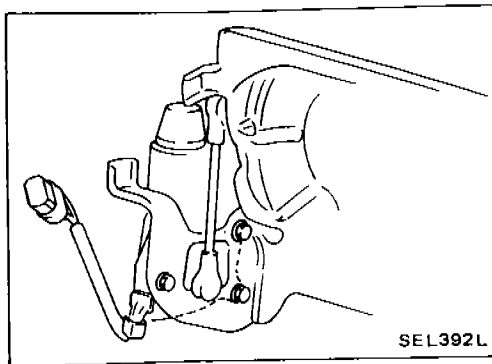

Assembly

1. Install headlamp motor, ball joint and link A (as one unit) on headlamp bracket.
2. While turning link B, install link A's ball joint on headlamp housing's ball joint.
3. Set distance between centers of upper and lower ball joints as shown in figure at left, and tighten lock nuts.
4. Assemble headlamp, finisher and lid.

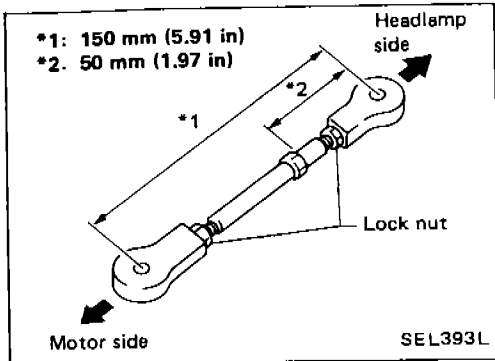

Installation and Adjustment

Before doing this, be sure to disconnect battery ground cable.

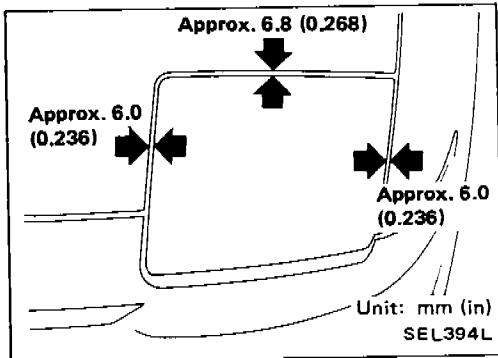

1. Install headlamp bracket to body temporarily.
 - 1) Determine headlamp bracket location on body so that alignment between lid, hood, and fender looks straight.
 - 2) After adjusting alignment, tighten headlamp bracket to body.

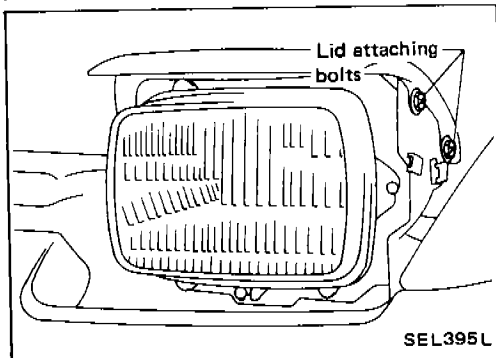

2. Adjust lid alignment.

- Adjust lid, hood and fender for alignment while opening and closing headlamp with motor manual knob.
Use motor manual knob to open and close headlamp, and adjust alignment while checking that lid is not interfering with hood.

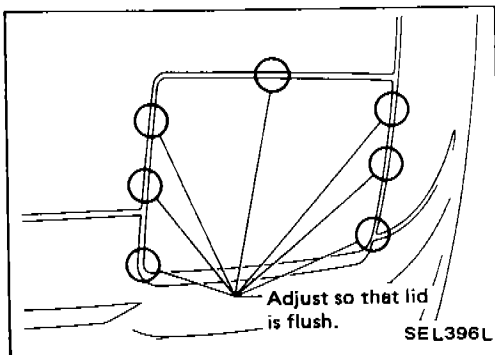

HEADLAMP

Installation and Adjustment (Cont'd)

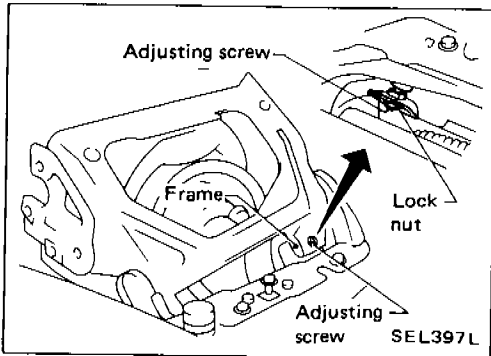

3. Adjust stopper.
 - 1) Loosen lock nut on stopper.
 - 2) Turn motor manual knob to open headlamp assembly completely.
 - 3) Adjust stopper screw.

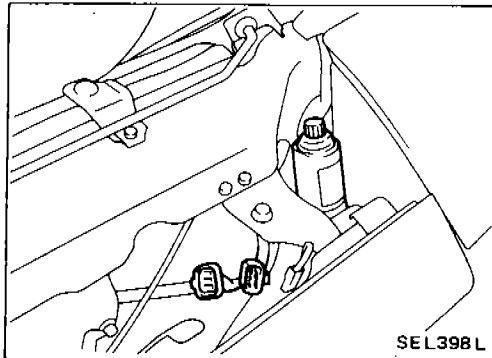

Headlamp Motor Check

1. Disconnect battery ground cable.
2. Disconnect the headlamp motor connector.
3. Use an ohmmeter to check for continuity in headlamp motor circuit while rotating motor with manual knob.

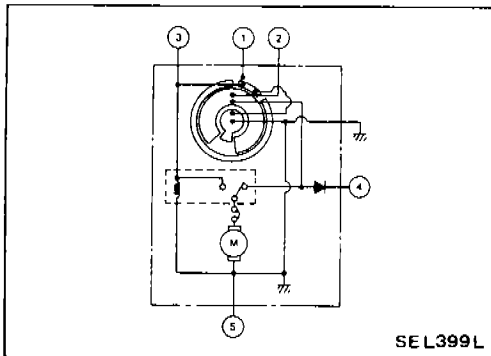

| Link A position | Ohmmeter probe | | Continuity |
|-----------------|----------------|-----|------------|
| | (+) | (-) | |
| "CLOSE" | ① | ⑤ | YES |
| | ② | ⑤ | NO |
| | ① | ③ | NO |
| | ③ | ① | YES |
| "OPEN" | ① | ⑤ | NO |
| | ② | ⑤ | YES |
| | ② | ④ | NO |
| | ④ | ② | YES |

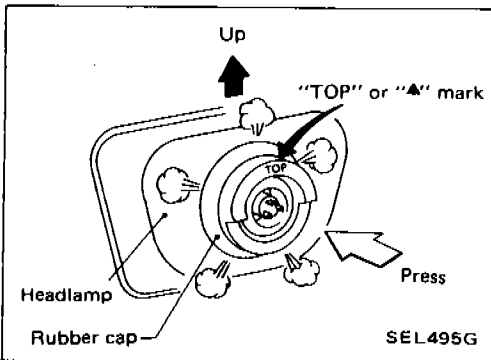

Bulb Replacement

INSTALLING HEADLAMP RUBBER CAP

When installing the rubber cap, set the "TOP" or "▲" mark so that it is facing up.

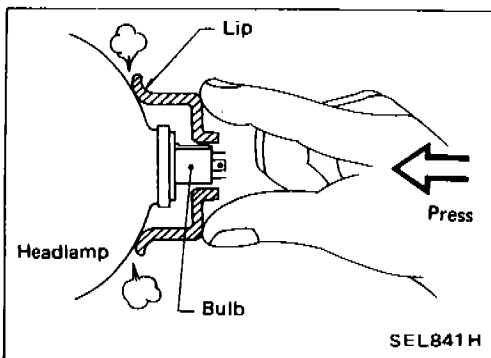

Press the rubber cap firmly so that the lip makes contact with the headlamp body.

HEADLAMP

Aiming Adjustment

When performing headlamp aiming adjustment, use an aiming machine, aiming wall screen or headlamp tester. For operating instructions of any aimer, it should be in good repair, calibrated and used according to respective operation manuals supplied with the unit.

If any aimer is not available, aiming adjustment can be done as follows:

For details, refer to the regulations in your own country.

CAUTION:

- Keep all tires inflated to correct pressures.
- Place vehicle and tester on one and same flat surface.
- See that there is no-load in vehicle (coolant, engine oil filled up to correct level and full fuel tank) other than the driver (or equivalent weight placed in driver's position).

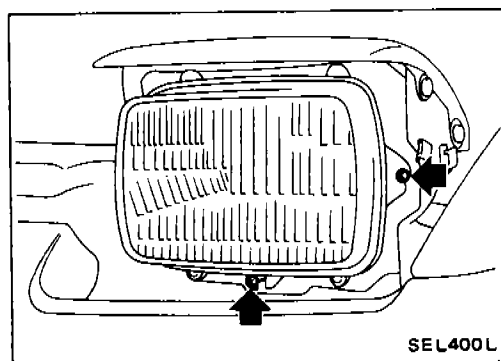

LOW BEAM

- Turn headlamp low beam on.
- Use adjusting screws to perform aiming adjustment.
 - First tighten the adjusting screw all the way and then make adjustment by loosening the screw.

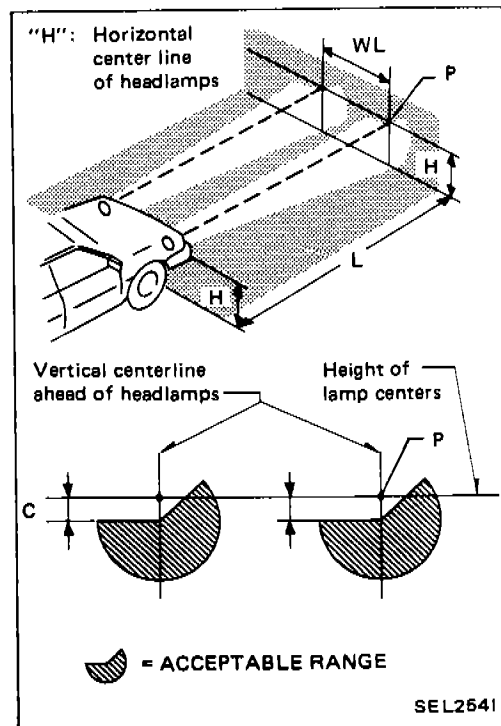

- Adjust headlamps so that main axis of light is parallel to center line of body and is aligned with point P shown in illustration.
- Figure to the left shows headlamp aiming pattern for driving on right side of road; for driving on left side of road, aiming pattern is reversed.
- Dotted lines in illustration show center of headlamp.

"H": Horizontal center line of headlamps

"WL": Distance between each headlamp center

"L": 5,000 mm (196.85 in)

"C": 50 mm (1.97 in)

EXTERIOR LAMP

Clearance, License, Tail and Stop Lamps/Wiring Diagram

L.H. DRIVE MODEL
FOR EUROPE

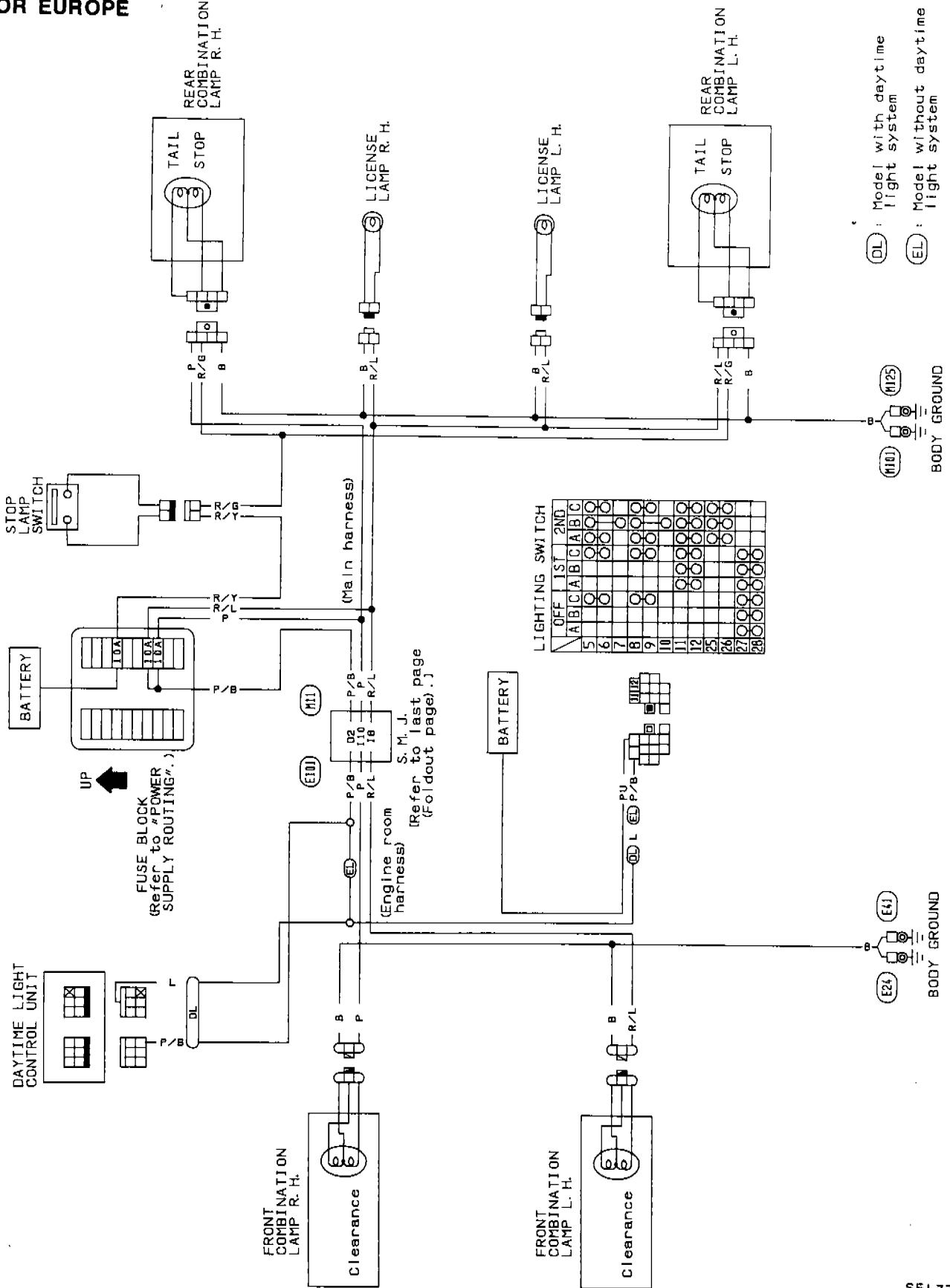

EXTERIOR LAMP

Clearance, License, Tail and Stop Lamps/Wiring Diagram (Cont'd)

EXCEPT L.H. DRIVE MODEL
FOR EUROPE

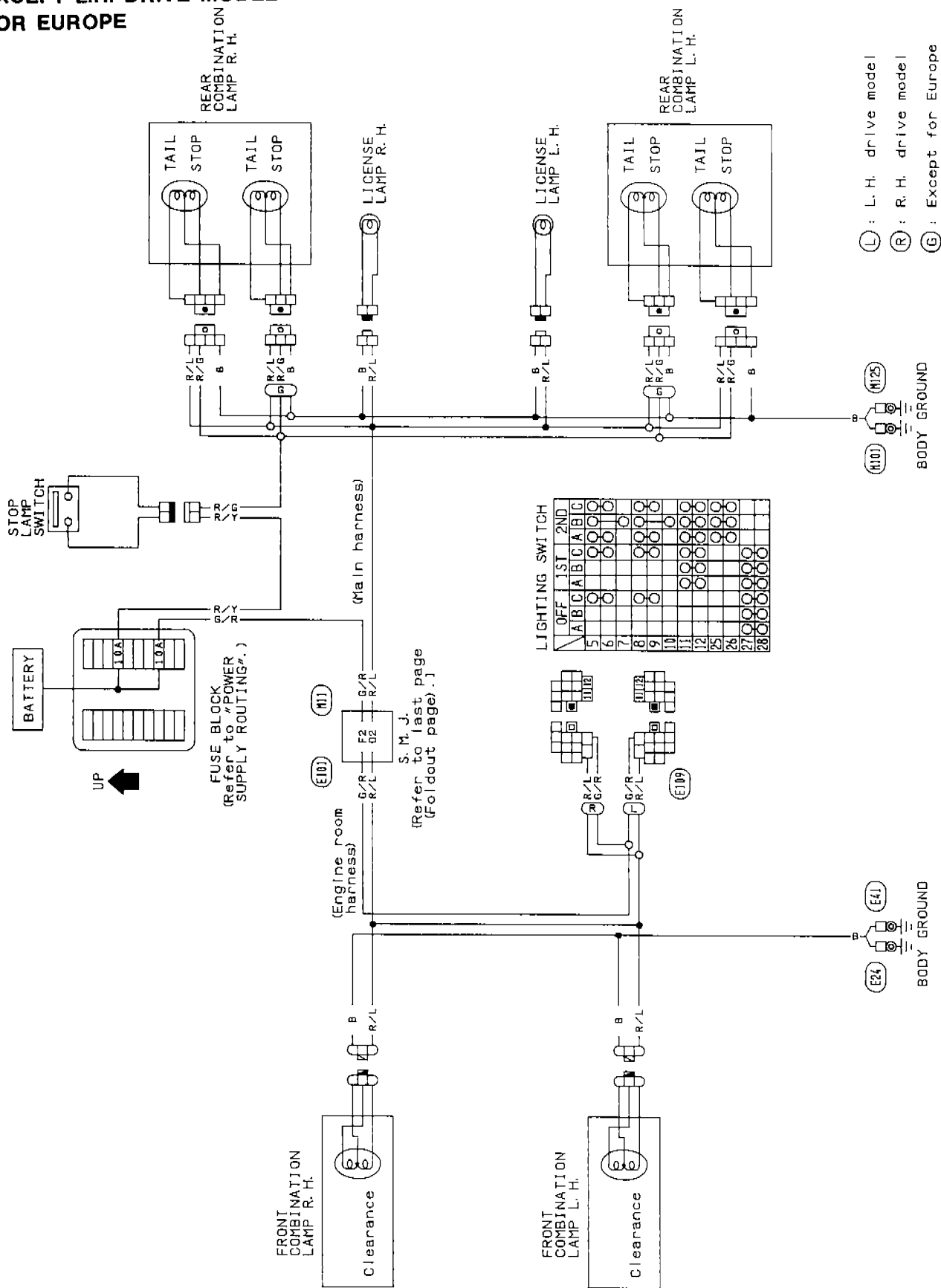

SEL774L

EXTERIOR LAMP

Back-up Lamp/Wiring Diagram

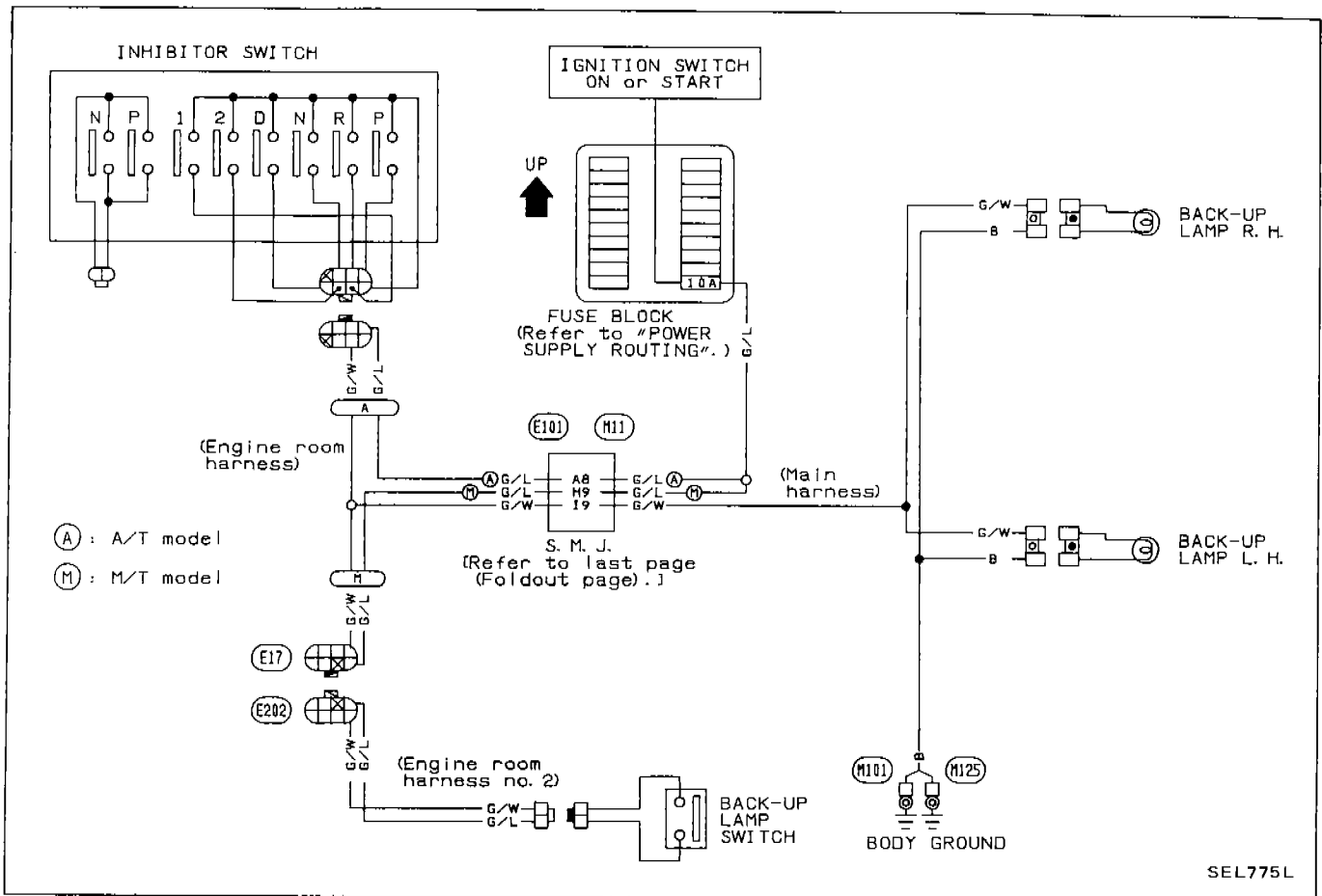

EXTERIOR LAMP

Rear Fog Lamp/Wiring Diagram

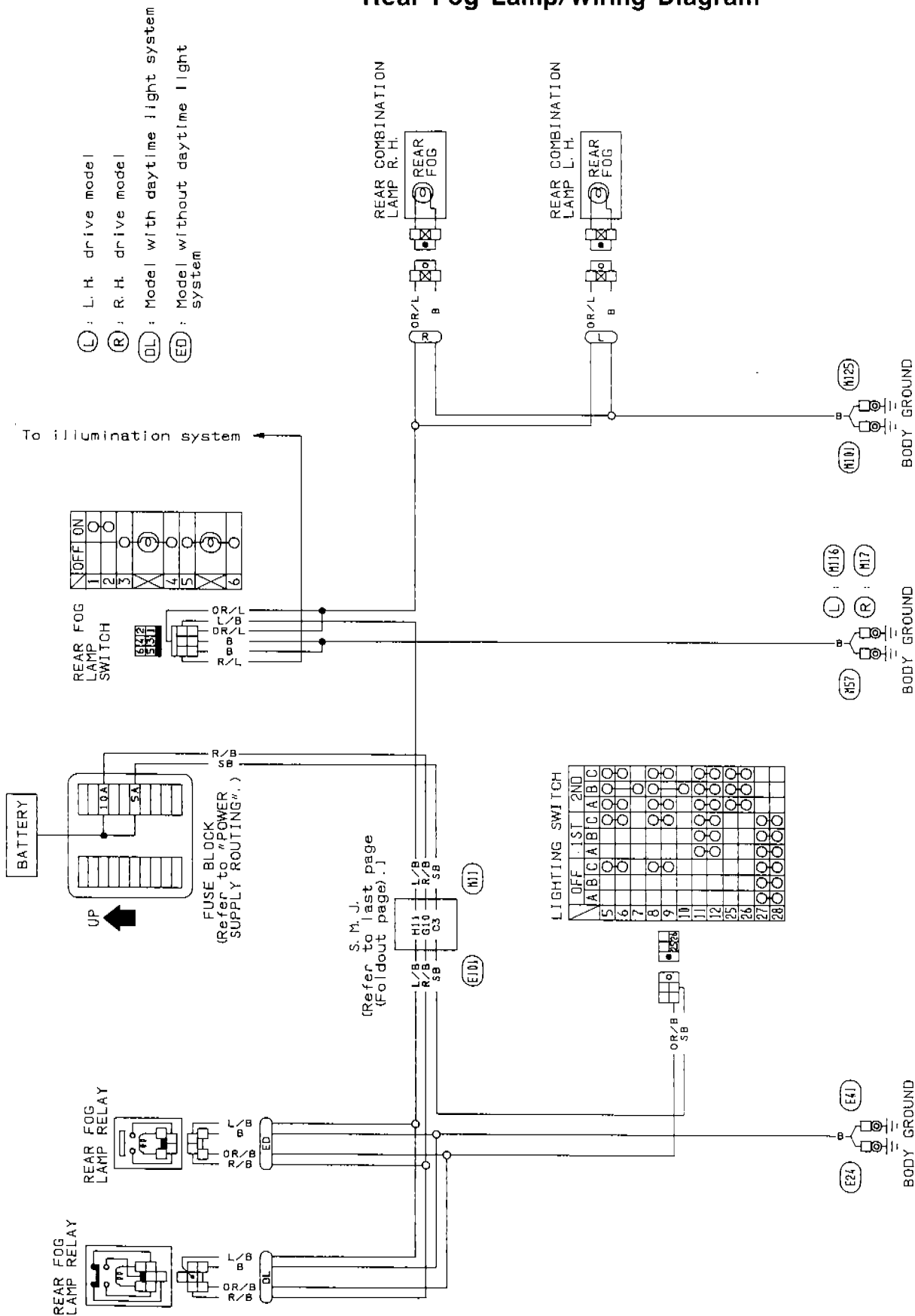

SEL776L

EXTERIOR LAMP

Daytime Light/Schematic

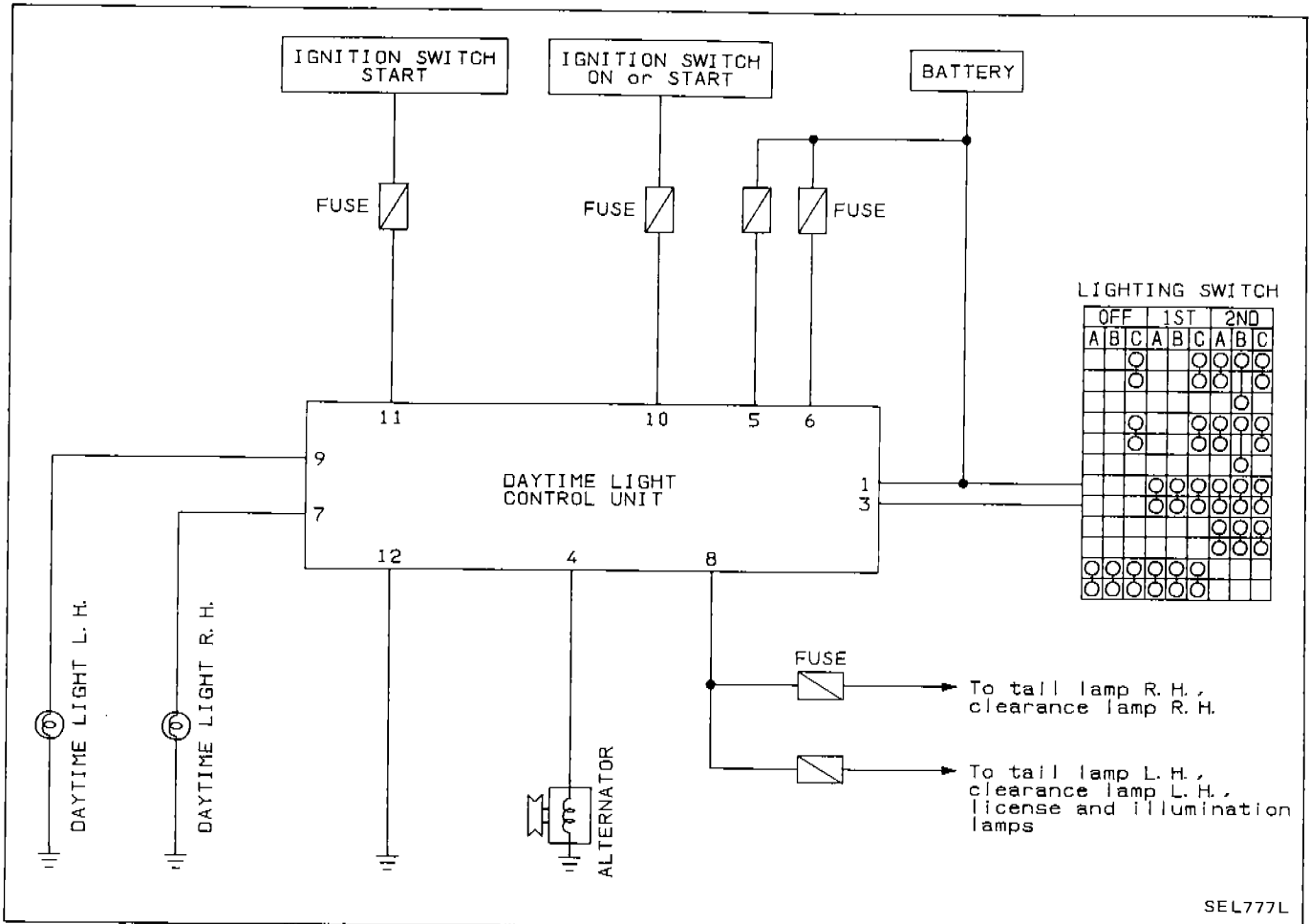

SEL777L

EXTERIOR LAMP

Daytime Light/Wiring Diagram

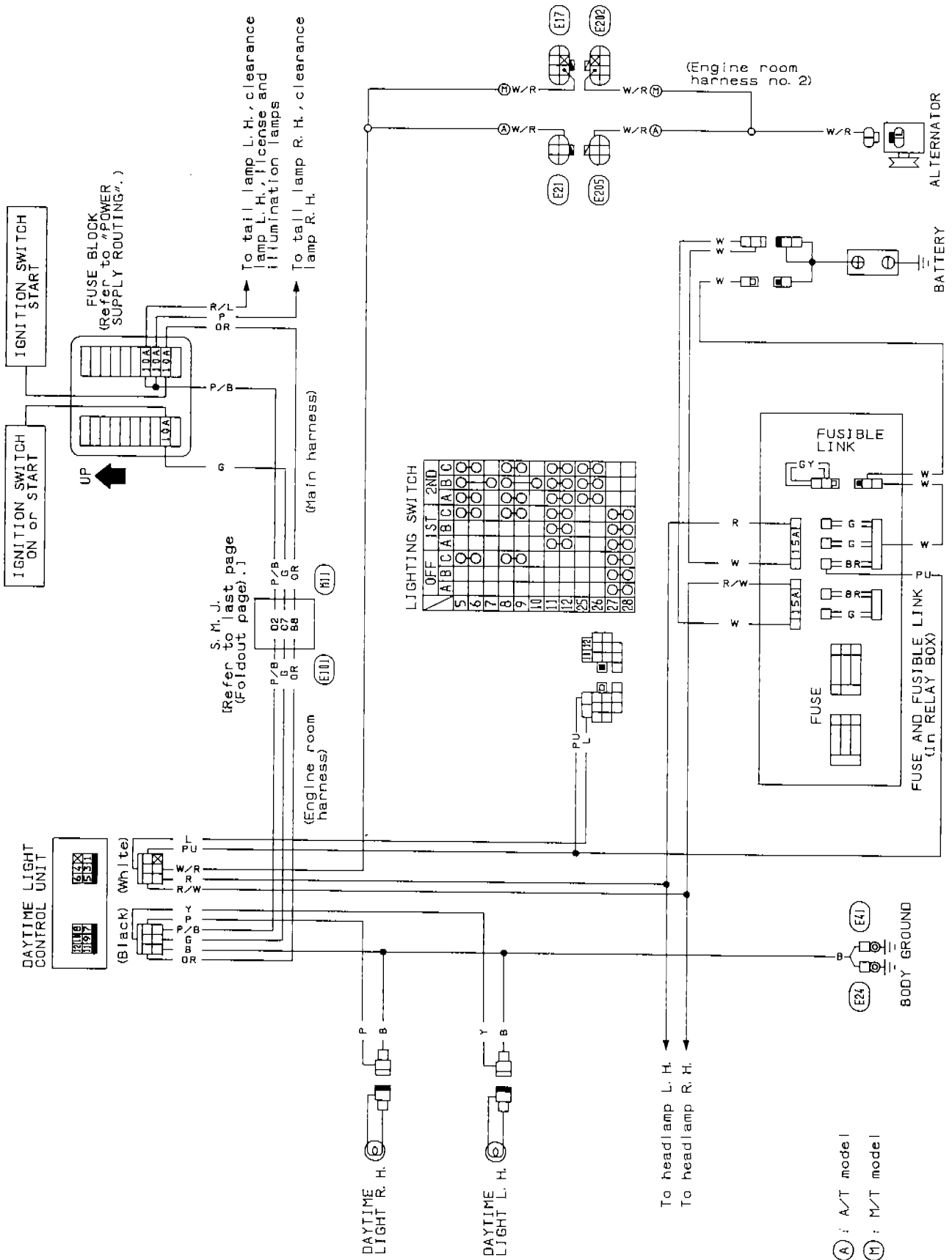

EXTERIOR LAMP

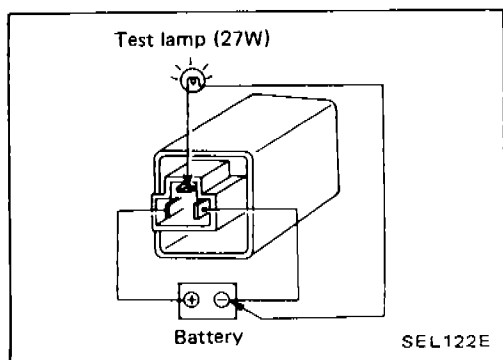

Combination Flasher Unit Check

- Before checking, ensure that bulbs meet specifications.
- Connect a battery and test lamp to the combination flasher unit, as shown. Combination flasher unit is properly functioning if it blinks when power is supplied to the circuit.

Bulb Specifications

| Item | Wattage (W) |
|----------------------------|-------------|
| Headlamp | 60/55 |
| Front combination lamp | |
| Turn signal/clearance lamp | 21/5 |
| Daytime running lamp | 27 |
| Side turn signal lamp | 5 |
| Rear combination lamp | |
| Stop/Tail | 21/5 |
| Turn signal | 21 |
| Rear fog | 21 |
| Back-up lamp | 21 |
| License plate lamp | 5 |
| Interior lamp | 10 |
| Spot lamp | 8 |
| Luggage compartment lamp | 5 |

INTERIOR LAMP

Illumination/Wiring Diagram

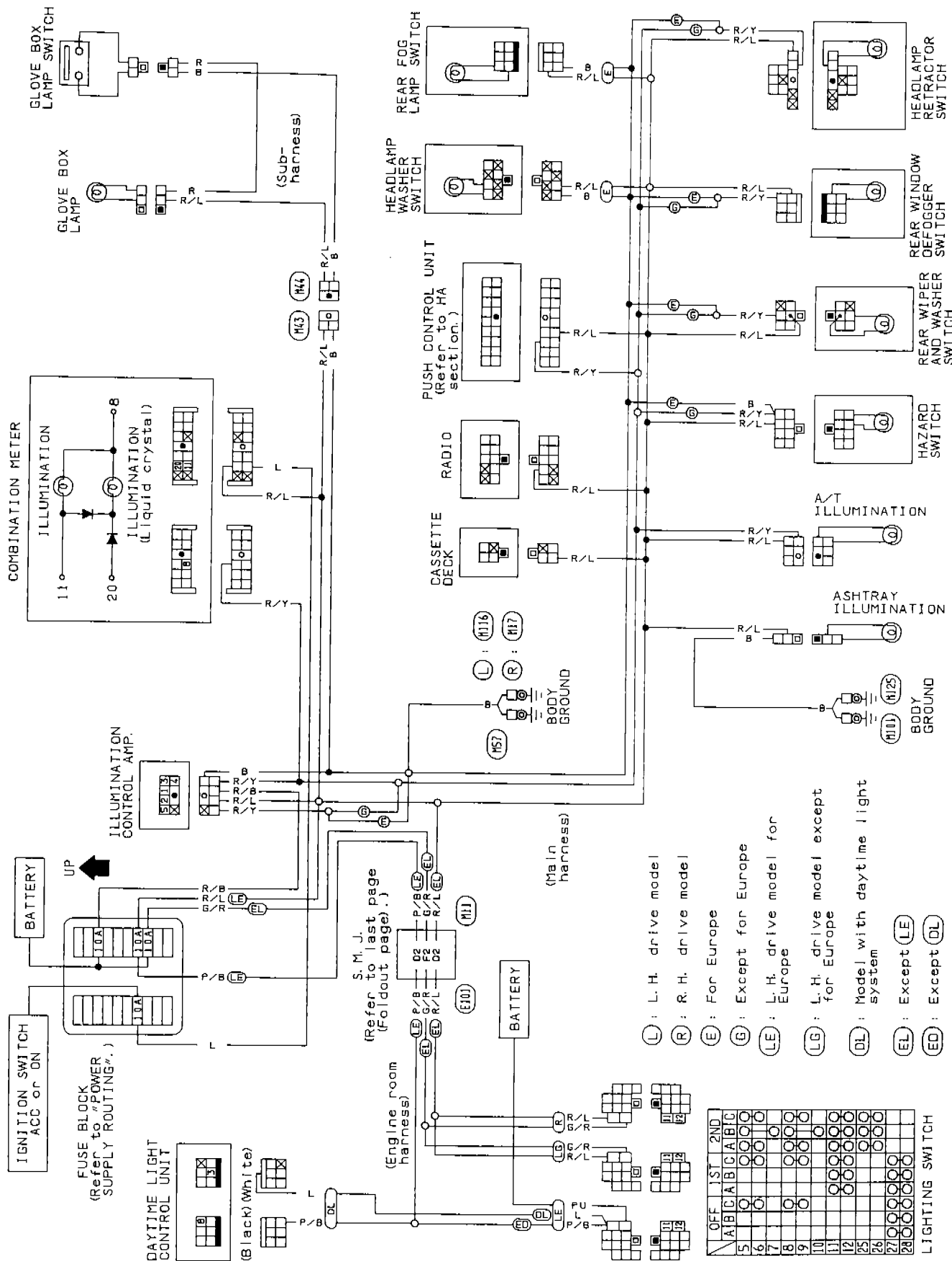

SEL780L

INTERIOR LAMP

Interior Lamp/Wiring Diagram

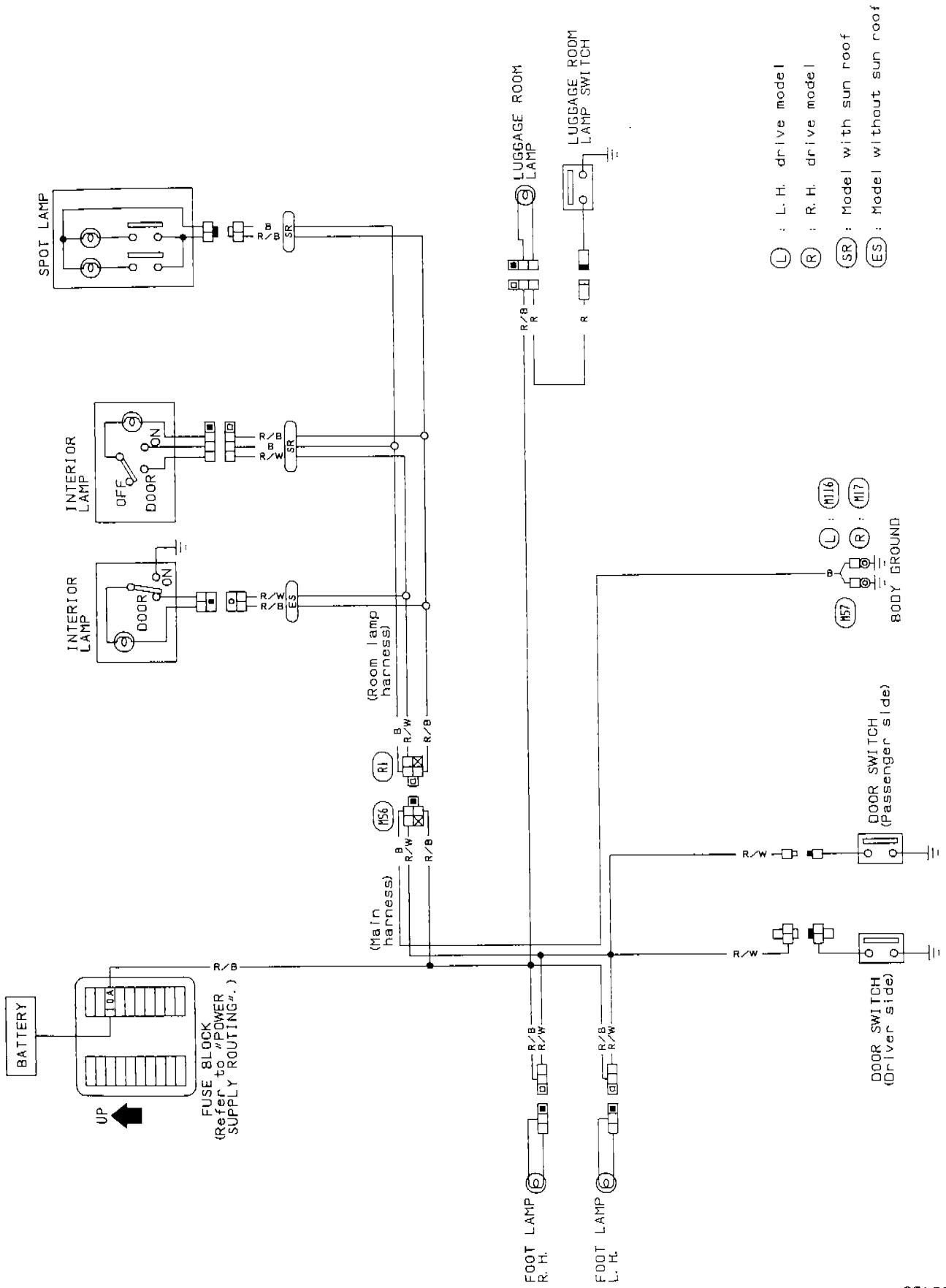

- (L) : L. H. drive model
- (R) : R. H. drive model
- (SR) : Model with sun roof
- (ES) : Model without sun roof

- (M116) : L
- (M117) : R
- (M57) : BODY GROUND

METER AND GAUGES

Combination Meter

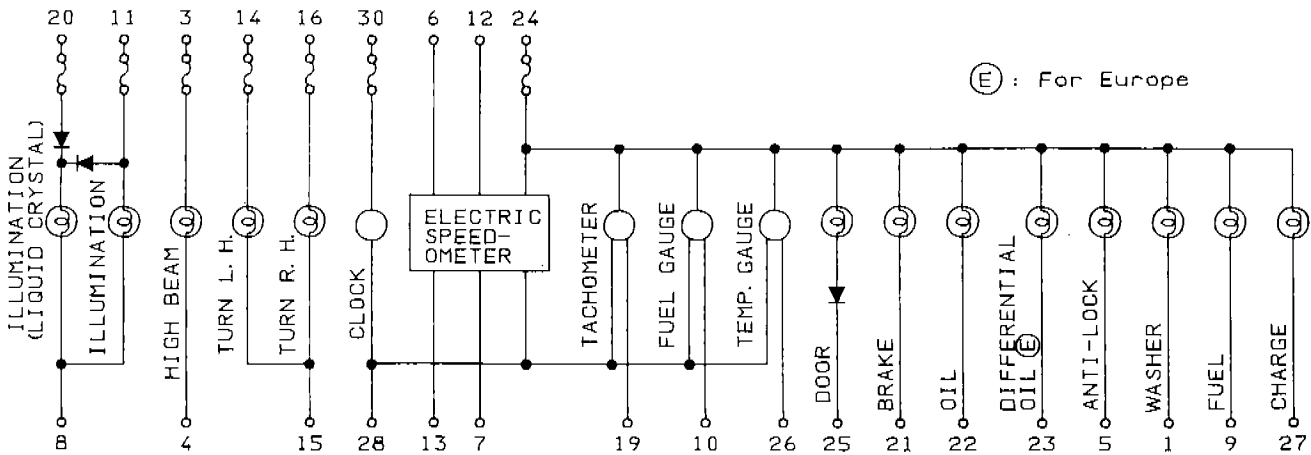
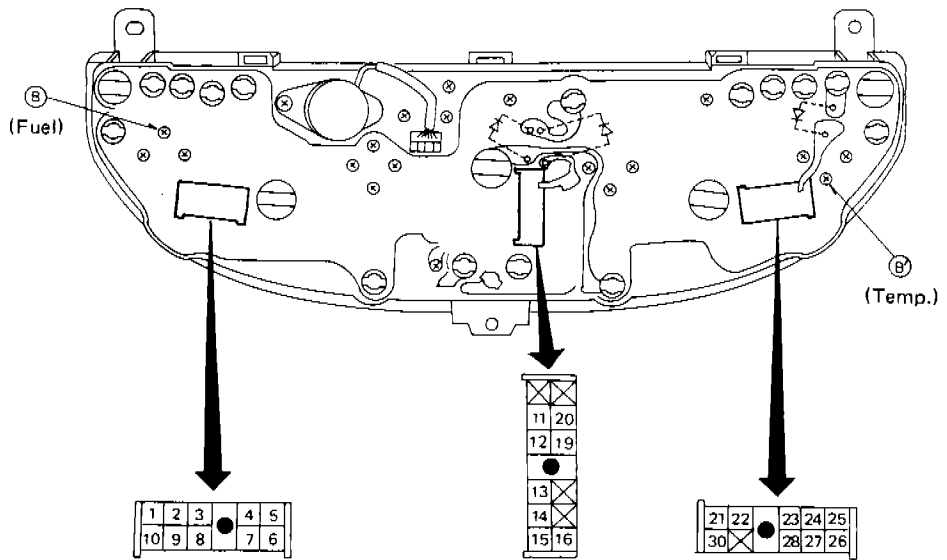
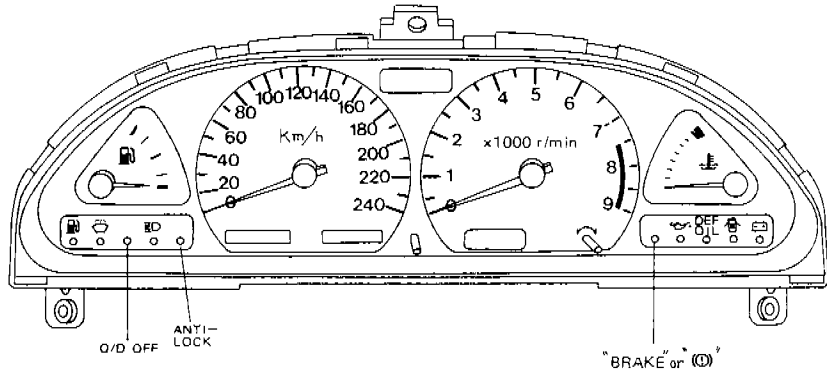
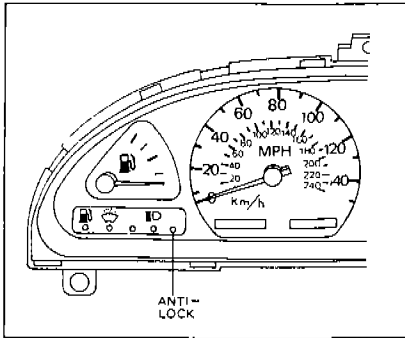

SEL698L

METER AND GAUGES

Inspection/Fuel Gauge and Water Temperature Gauge

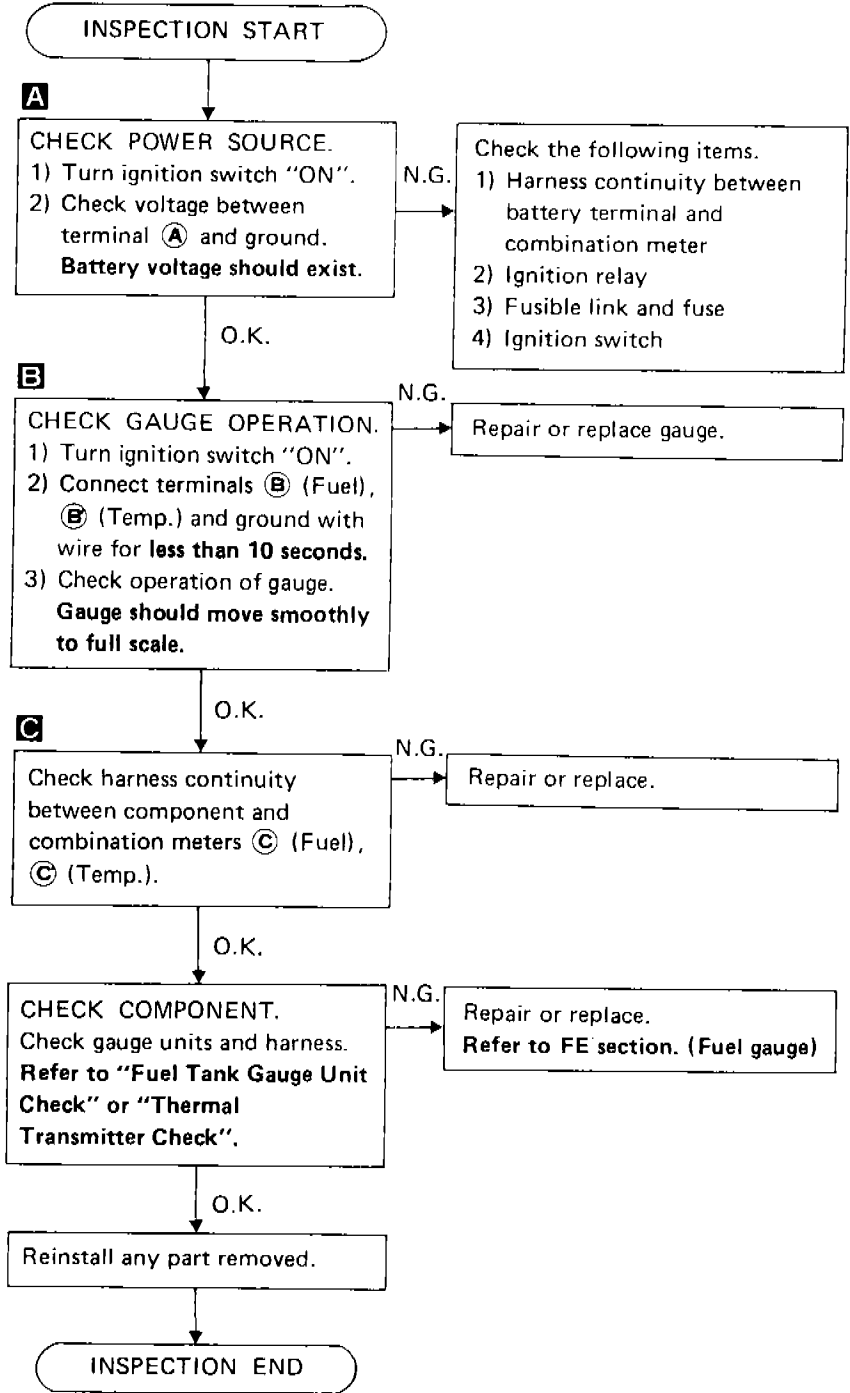
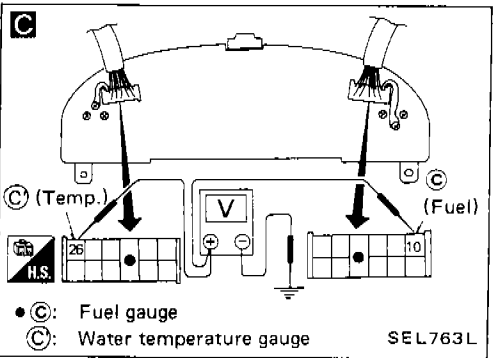
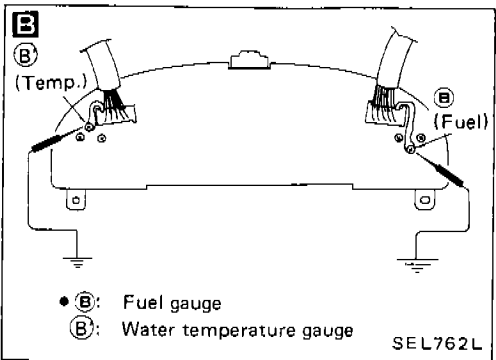
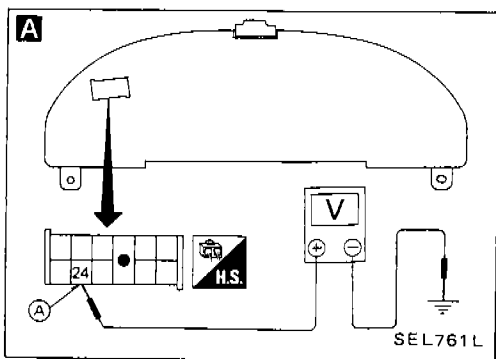

METER AND GAUGES

Fuel Tank Gauge Unit Check

- For removal, refer to FE section.
- Check the resistance between terminals **G** and **E**.

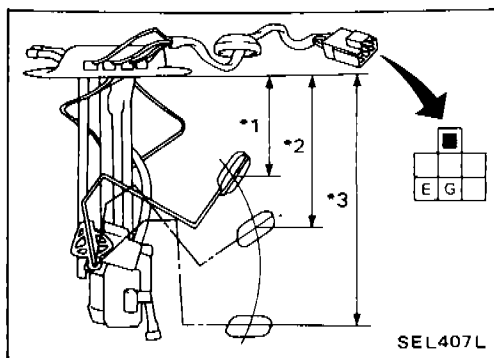

| Ohmmeter | | Float position | | Resistance Ω | Fuel value ℓ (Imp gal) | |
|----------|-----|----------------|---------|------------------------|--------------------------------|---------------|
| (+) | (-) | | mm (in) | | | |
| G | E | *1 | Full | Approx. 64 (2.52) | 4.3 - 6.3 | 57.6 (12-5/8) |
| | | *2 | 1/2 | Approx. 137 (5.39) | 27.7 - 34.3 | 32.9 (7-1/4) |
| | | *3 | Empty | Approx. 210 (8.27) | 73.3 - 84.8 | 7.2 (1-5/8) |

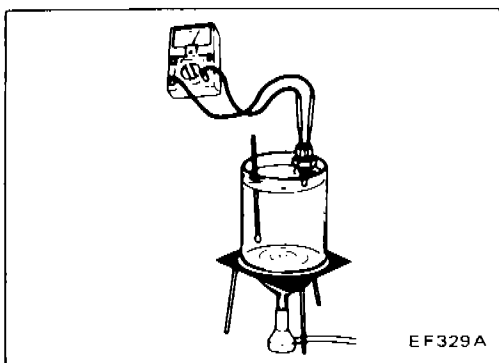

Thermal Transmitter Check

Check the resistance between the terminals of thermal transmitter and body ground.

| Water temperature | Resistance |
|-------------------|--------------------------|
| 60°C (140°F) | Approx. 70 - 90 Ω |
| 100°C (212°F) | Approx. 21 - 24 Ω |

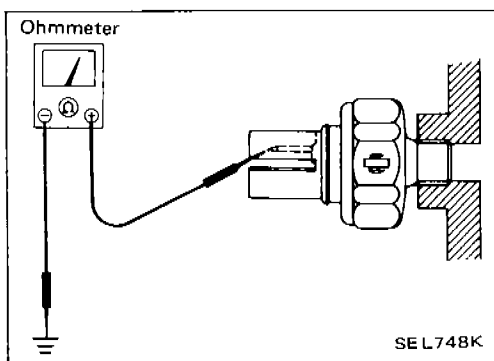

Oil Pressure Switch Check

Check the continuity between the terminals of oil pressure switch and body ground.

| | Oil pressure kPa (bar, kg/cm ² , psi) | Continuity |
|--------------|----------------------------------------------------------|------------|
| Engine start | More than 10 - 20 (0.10 - 0.20, 0.1 - 0.2, 1.4 - 2.8) | NO |
| Engine stop | Less than 10 - 20 (0.10 - 0.20, 0.1 - 0.2, 1.4 - 2.8) | YES |

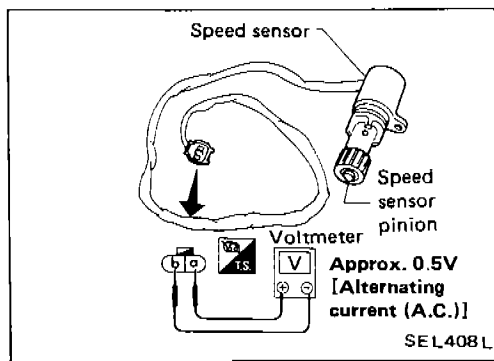

Speed Sensor Signal Check

1. Remove speed sensor from transmission.
Location: Refer to "Location of Electrical Units".
2. Turn speedometer pinion quickly and measure voltage across **a** and **b**.

WARNING LAMPS AND CHIME

Warning Lamps/Schematic

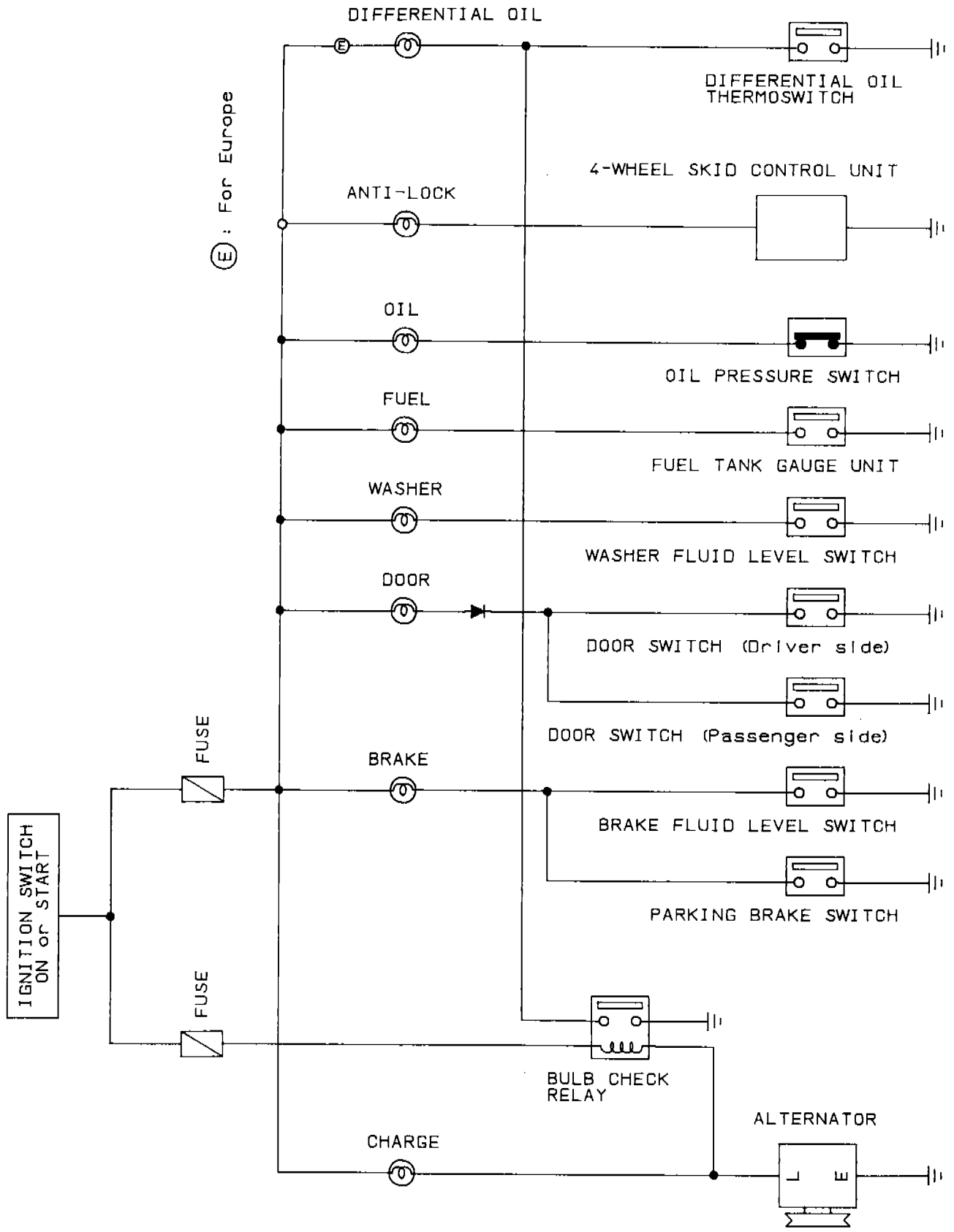

SEL783L

WARNING LAMPS AND CHIME

Warning Chime/Wiring Diagram

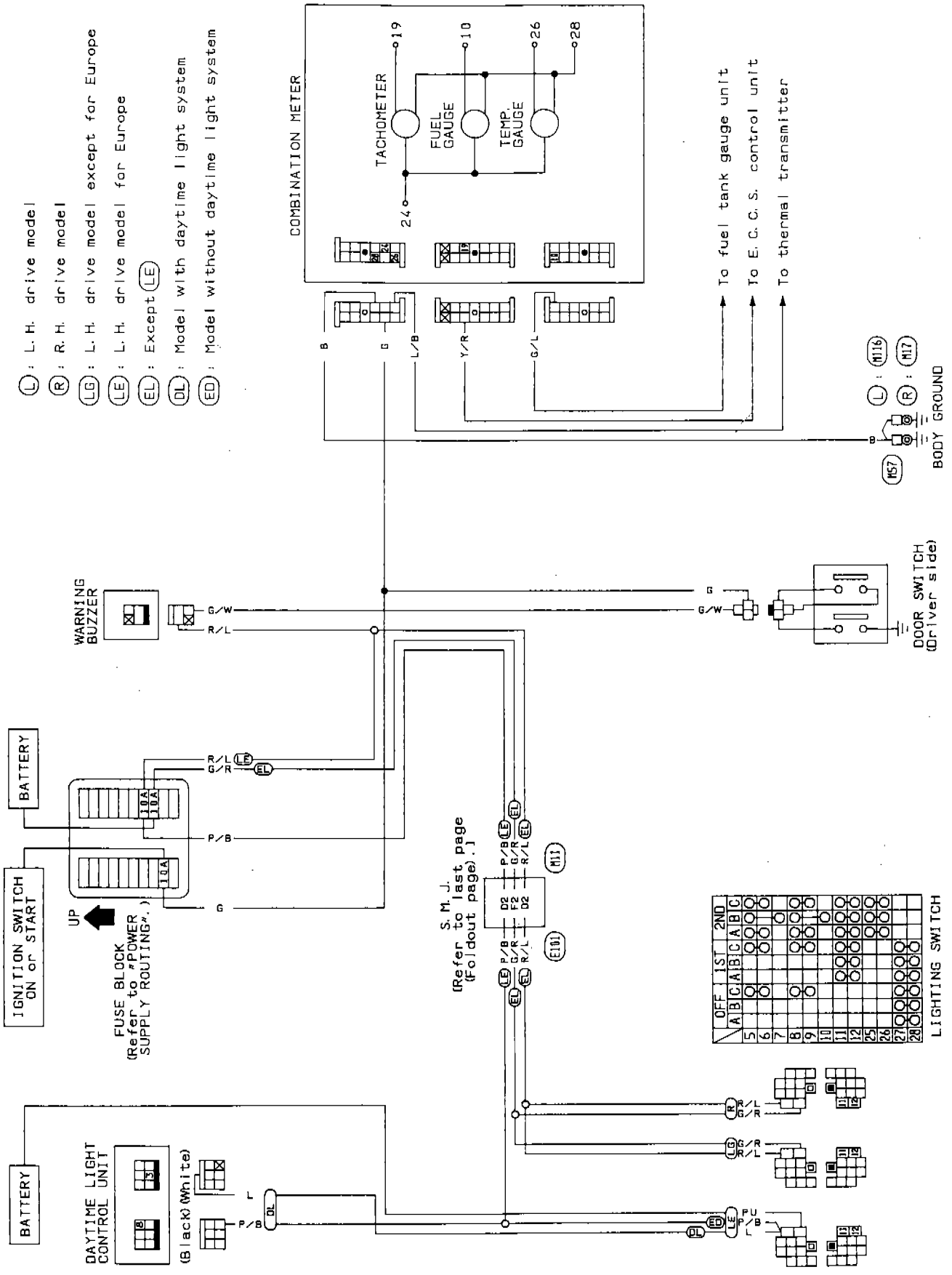

WARNING LAMPS AND CHIME

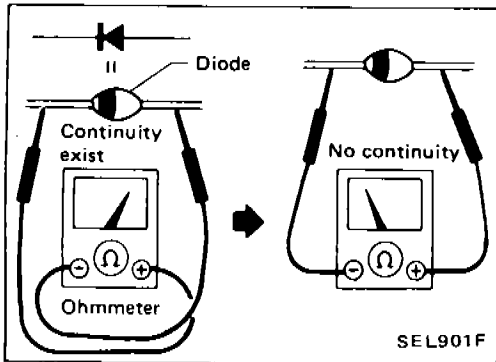

Diode Check

- Check continuity using an ohmmeter.
- Diode is functioning properly if test results are as shown in the figure at left.

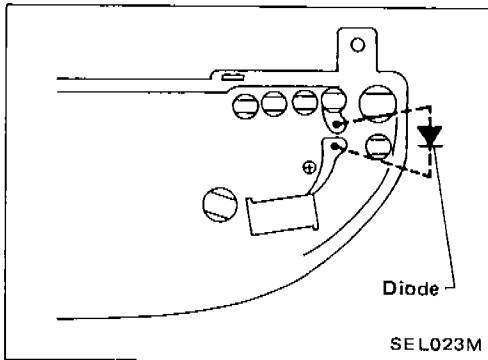

- Diodes for warning lamps are built into the combination meter printed circuit.

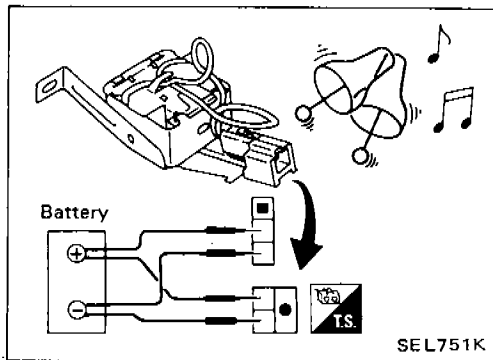

Warning Chime Check

WIPER AND WASHER

Front Wiper and Washer/Wiring Diagram

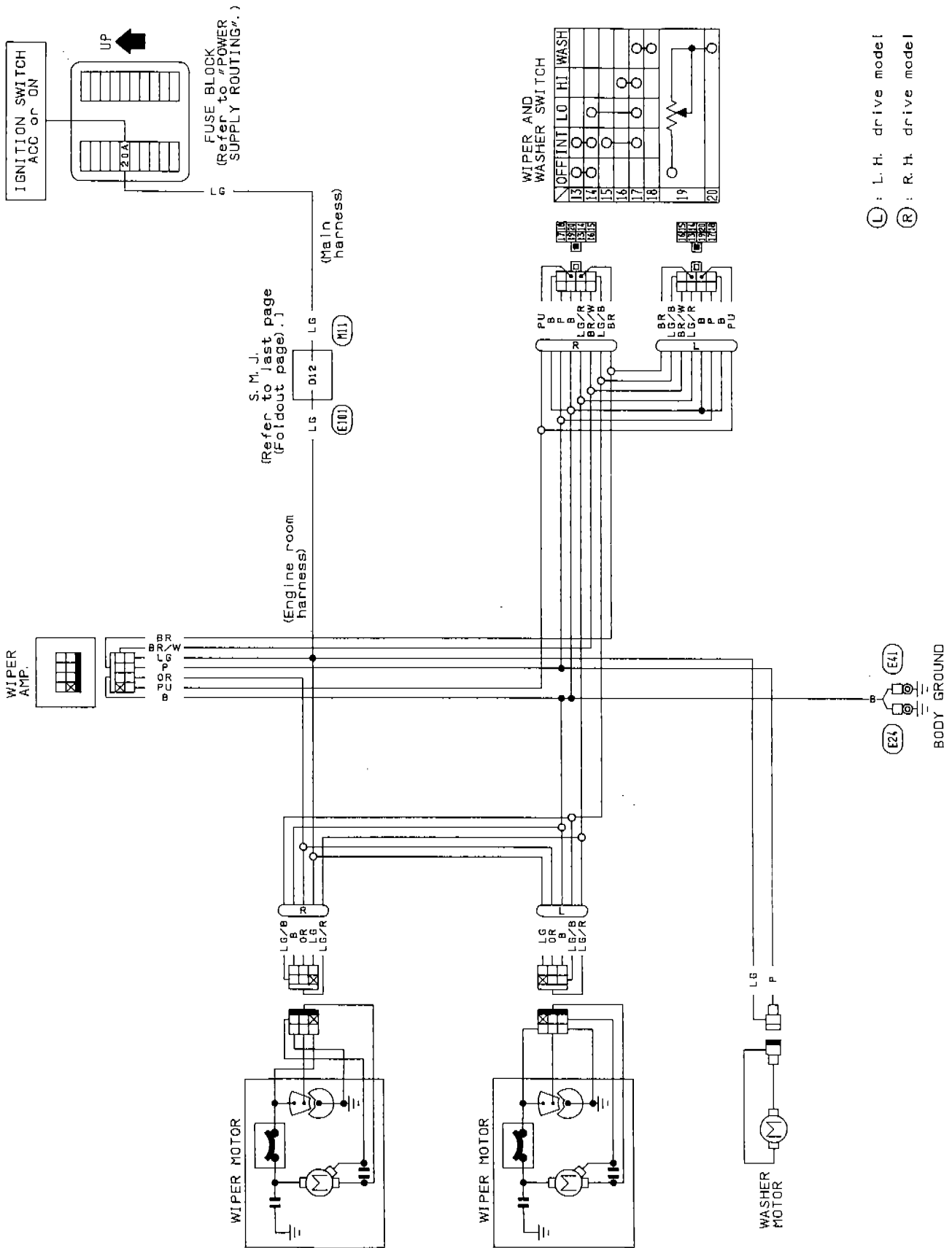

(L) : L. H. drive model
(R) : R. H. drive model

WIPER AND WASHER

Rear Wiper and Washer/Wiring Diagram

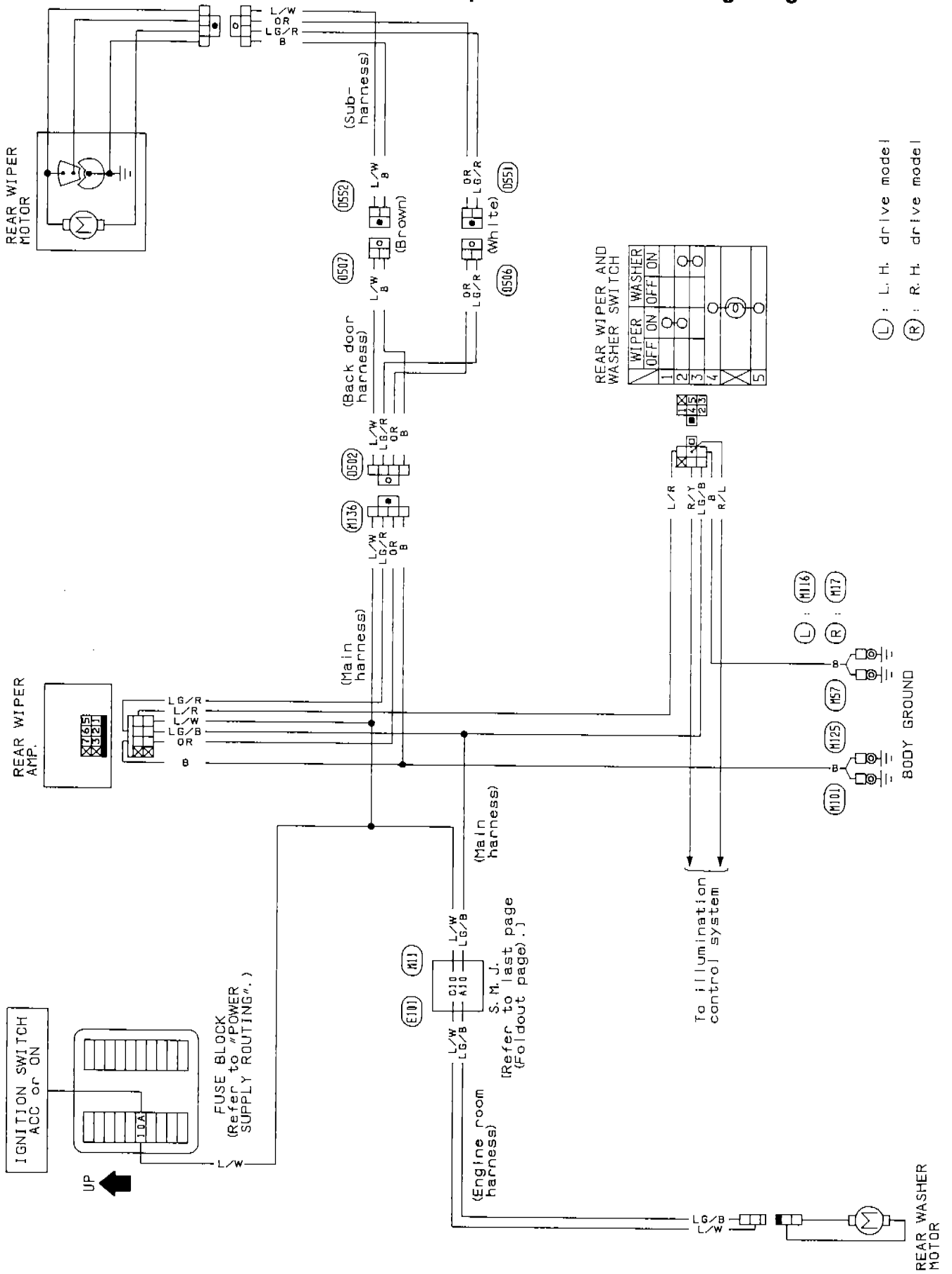

WIPER AND WASHER

Headlamp Wiper and Washer/Wiring Diagram

(L) : L. H. drive model
 (R) : R. H. drive model

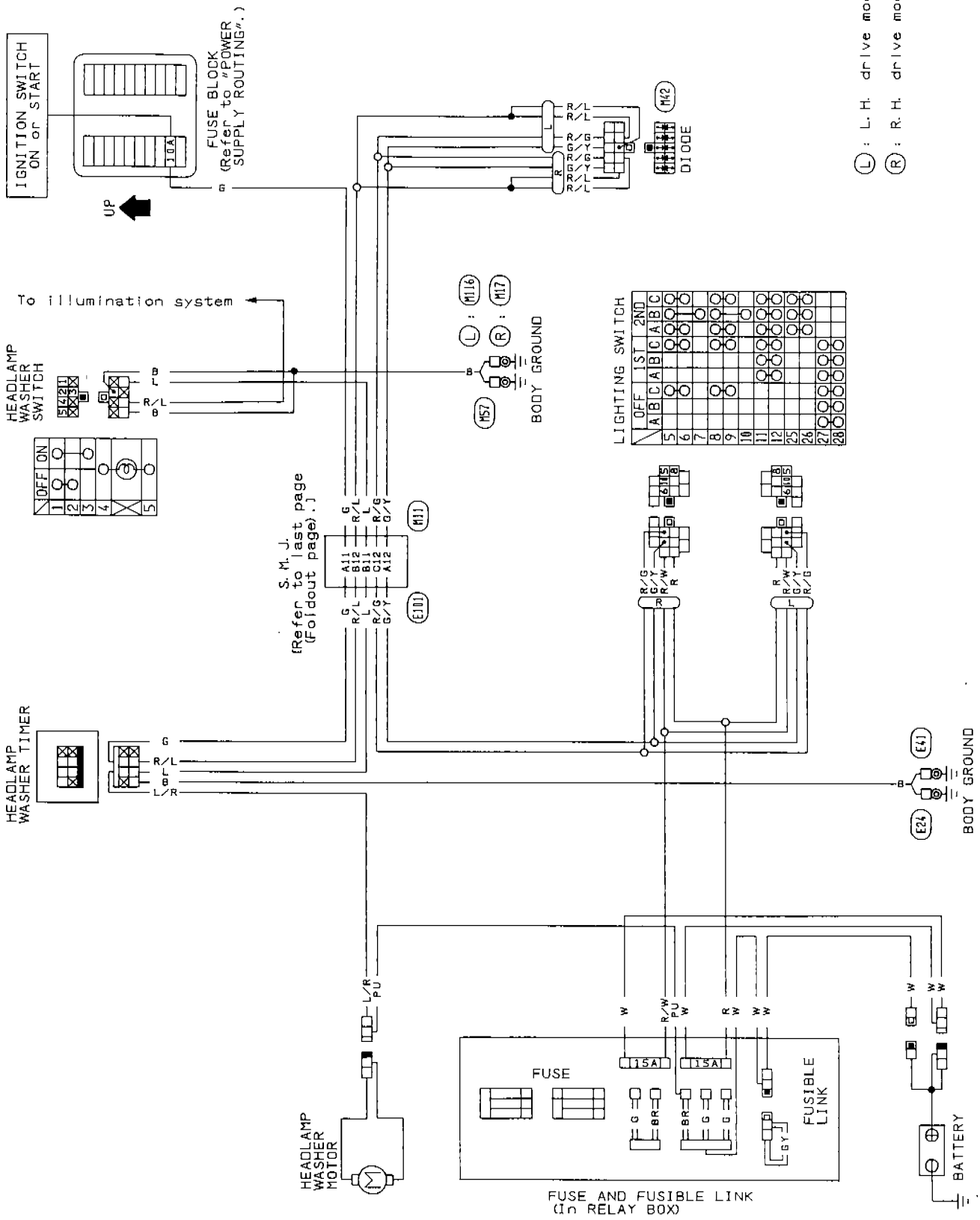

WIPER AND WASHER

Wiper Removal and Installation

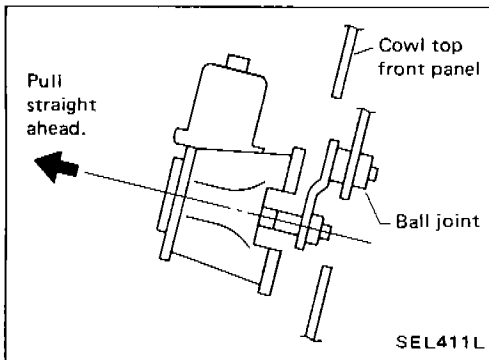
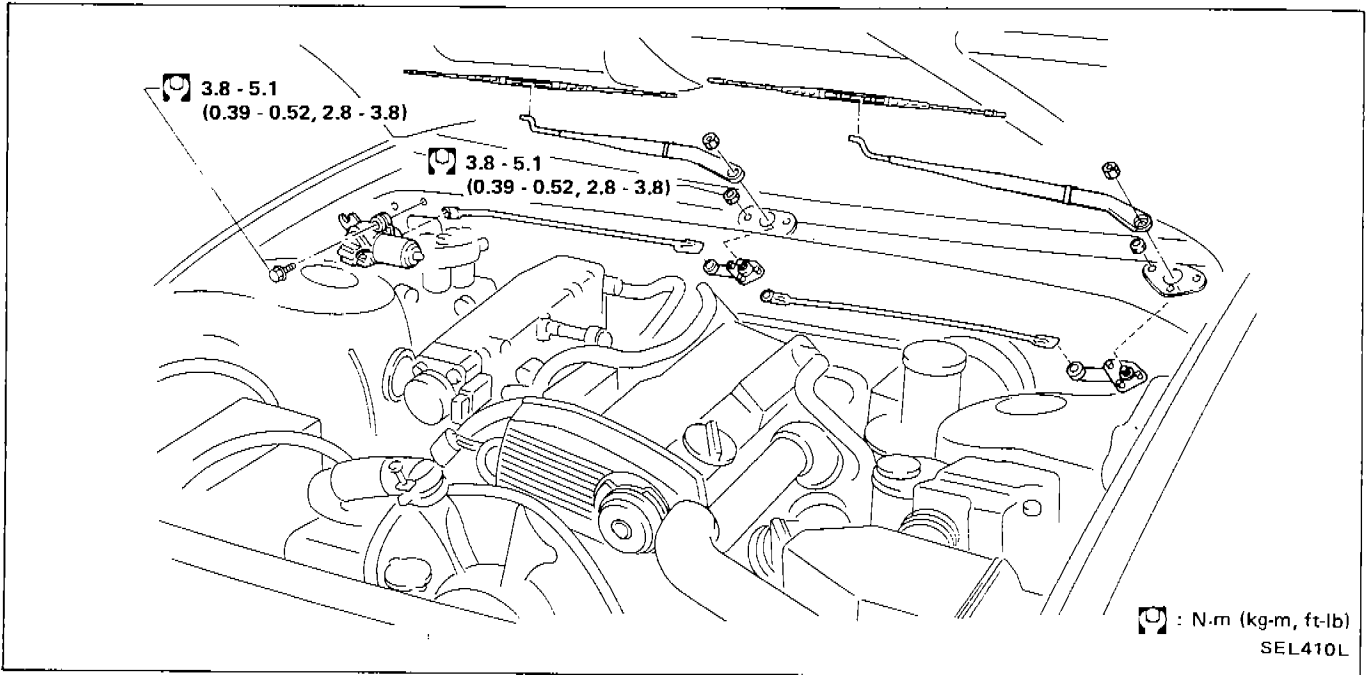

FRONT WIPER REMOVAL

Before removing front wiper motor link, turn wiper switch OFF and disconnect motor leads at connectors.

1. Remove wiper arm.
2. Remove cowl cover.
3. Remove bolts which secure wiper motor.
4. Extract wiper motor so that wiper motor link comes out of hole in front cowl top panel. Then, pull motor straight out to disconnect ball joint which connects motor link and wiper link. Wiper motor can then be removed.
5. Remove wiper link pivot blocks on driver and passenger sides.
6. Extract wiper link and pivot blocks (as one unit) from oblong hole on left side (L.H.D.) or right side (R.H.D.) of cowl top.

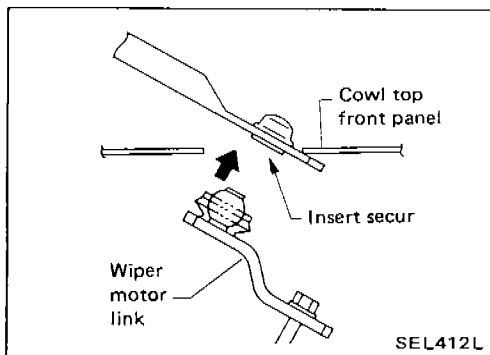

FRONT WIPER INSTALLATION

1. Position wiper link and pivot blocks (as one unit) in cowl top through oblong hole.
 2. Before installing pivot blocks on cowl top, hold end (motor link side) of wiper link at hole in front cowl top panel and insert motor link's ball pin into hole in wiper link.
 3. Install front wiper in reverse order of above removal procedures.
- Apply a small amount of grease to ball joints before installation.

WIPER AND WASHER

Variable Pressure Window Screen Wiper/Wiring Diagram

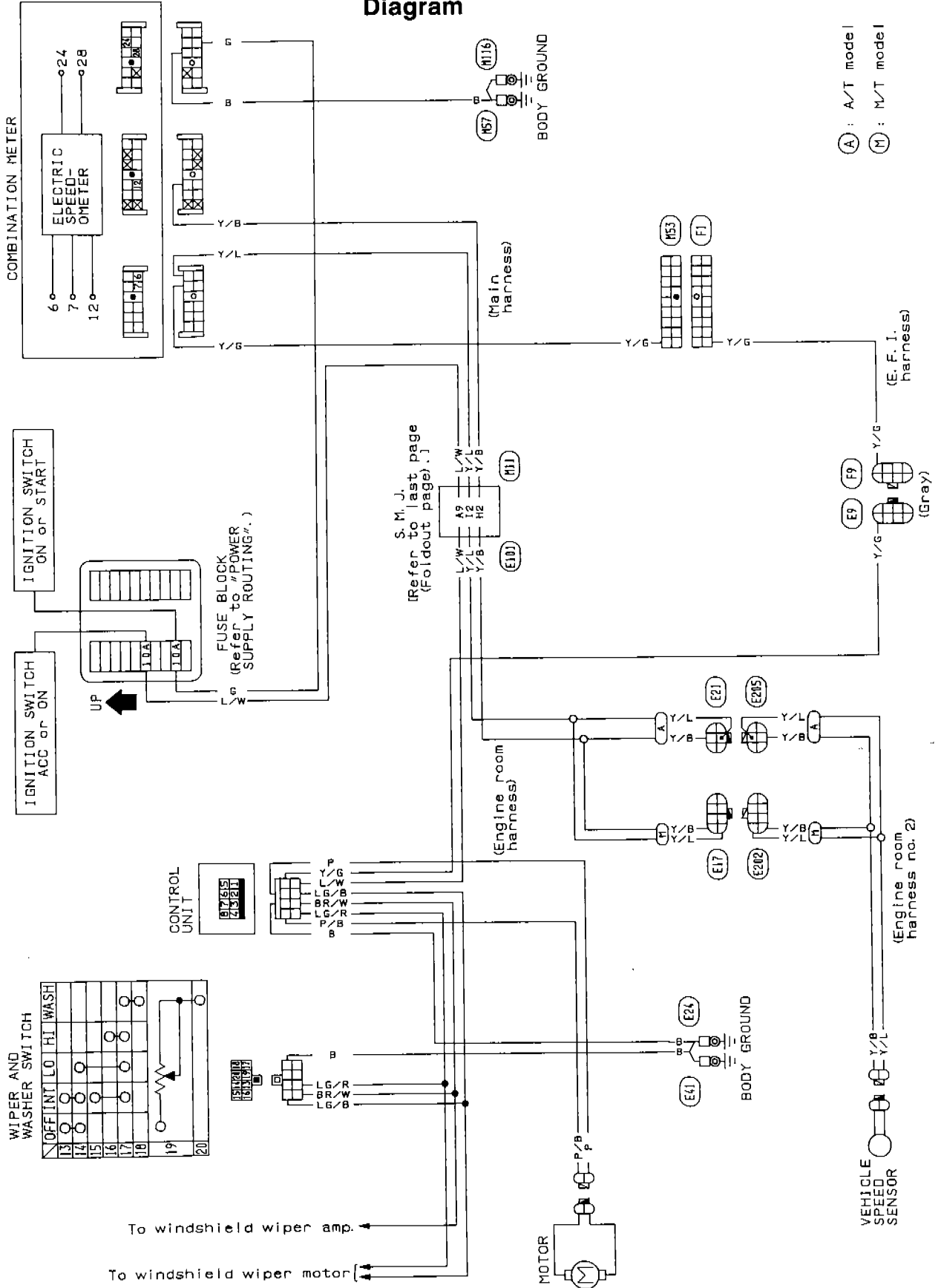

WIPER AND WASHER

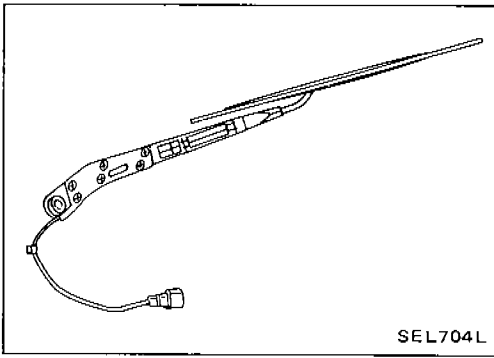

Wiper Arm (For Europe L.H.D. model)

The wiper arm pressure is controlled by the vehicle speed when the wiper switch is in the "ON" position.

| Vehicle speed | km/h (MPH) | Wiper arm pressure |
|---------------|------------|--------------------|
| More than | 130 (81) | Low → High |
| Less than | 120 (75) | High → Low |

Wiper and Washer Adjustment

INSTALLATION

1. Prior to wiper arm installation, turn on wiper switch to operate wiper motor and then turn it "OFF" (Auto Stop).
2. Lift the blade up and then set it down onto glass surface to set the blade center to clearance "L₁" & "L₂" immediately before tightening nut.
3. Eject washer fluid. Turn on wiper switch to operate wiper motor and then turn it "OFF".
4. Ensure that wiper blades stop within clearance "L₁" & "L₂".

Clearance "L₁": 17.5 - 32.5 mm (0.689 - 1.280 in)

Clearance "L₂": 25 - 35 mm (0.98 - 1.38 in)

- Tighten wiper arm nuts to specified torque.

Front wiper: 17 - 23 N·m (1.7 - 2.3 kg-m, 12 - 17 ft-lb)

Rear wiper: 13 - 18 N·m (1.3 - 1.8 kg-m, 9 - 13 ft-lb)

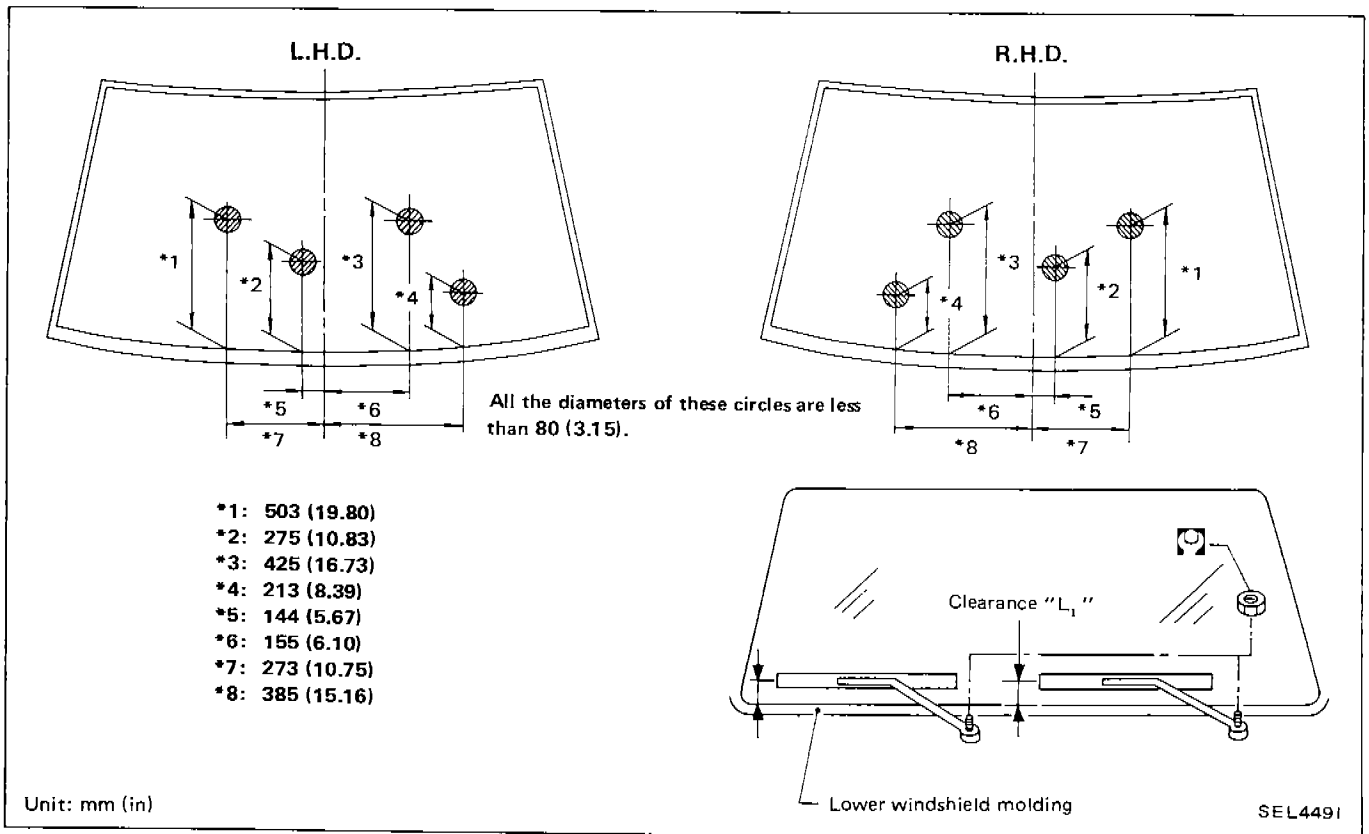

WIPER AND WASHER

Wiper and Washer Adjustment (Cont'd)

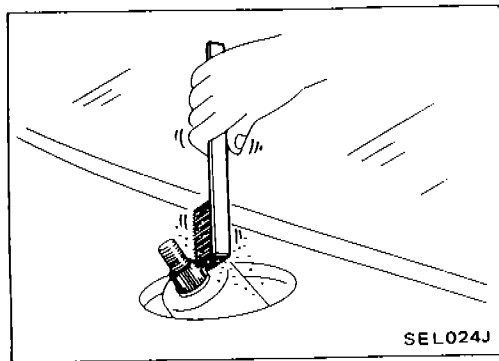
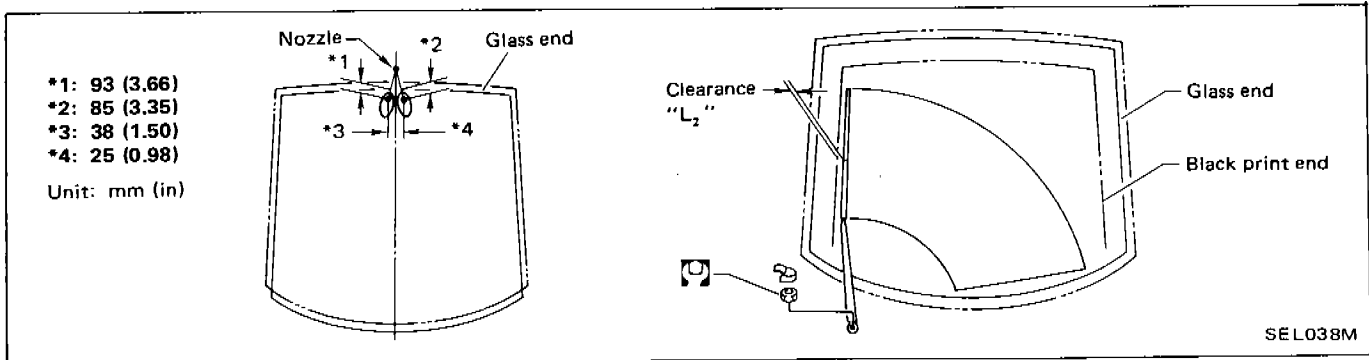

- Before reinstalling wiper arm, clean up the pivot area as illustrated. This will reduce possibility of wiper arm looseness.

Washer Nozzle Adjustment

- Adjust washer nozzle with suitable tool as shown in the figure at left. Details of tool are shown below.

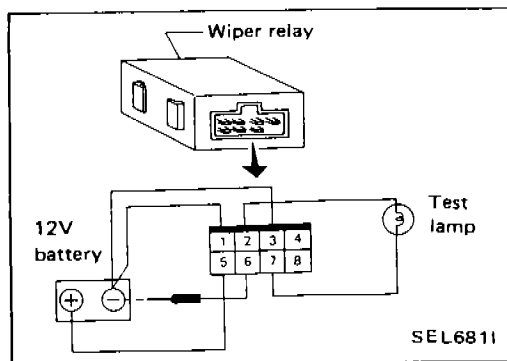
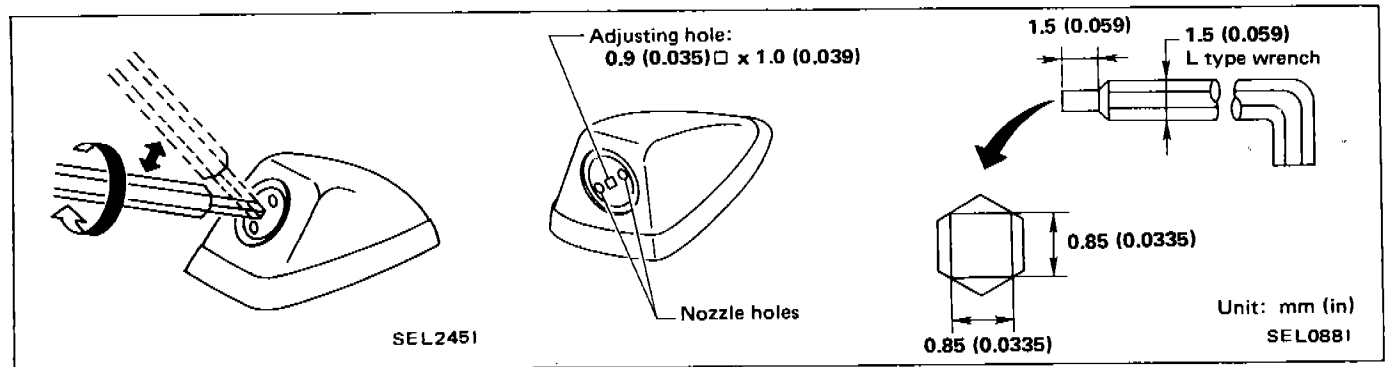

Wiper Amplifier Check

1. Connect as shown in the figure at left.
2. If test lamp comes on when connected to terminal ⑥ and battery ground, wiper relay is normal.

WIPER AND WASHER

Washer Tube Layout

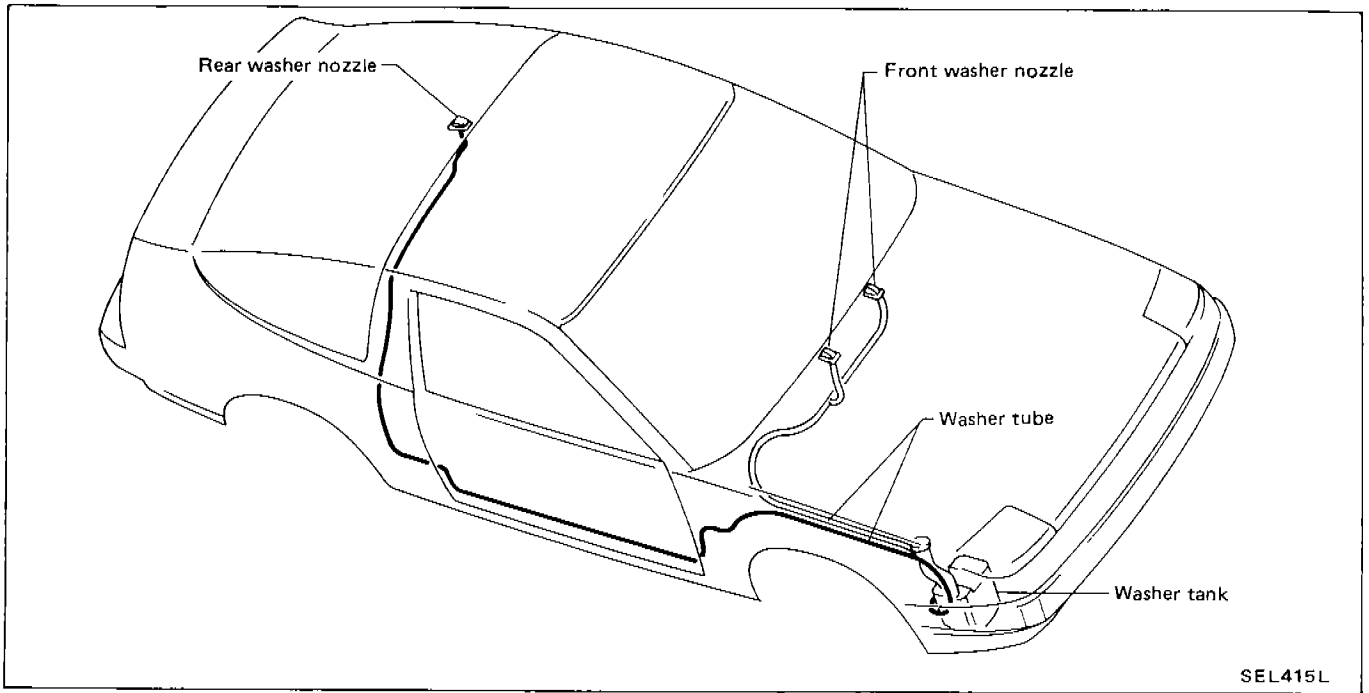

HORN, CIGARETTE LIGHTER AND CLOCK

Wiring Diagram

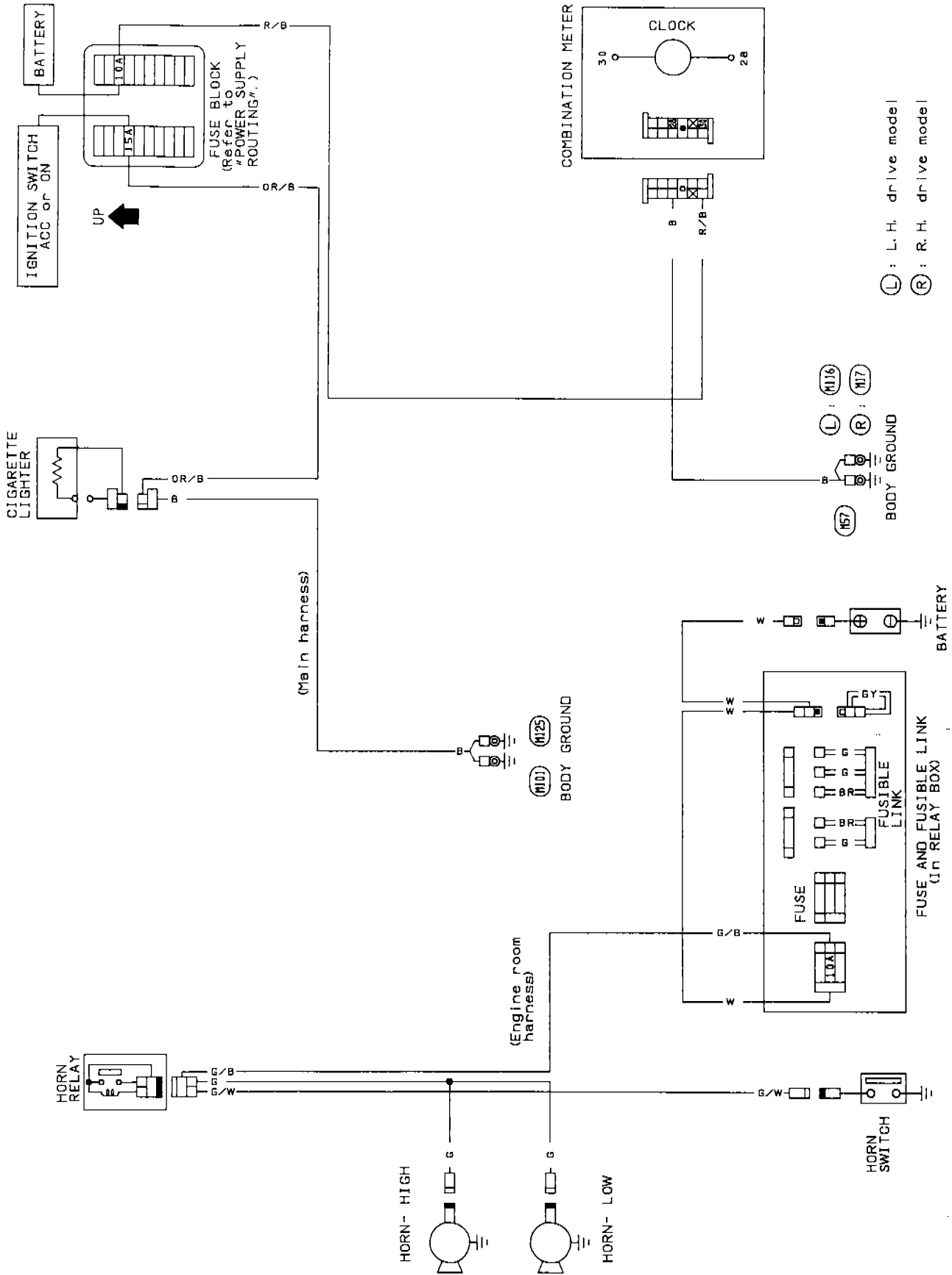

SEL790L

REAR WINDOW DEFOGGER

Filament Check

1. Attach probe circuit tester (in volt range) to middle portion of each filament.

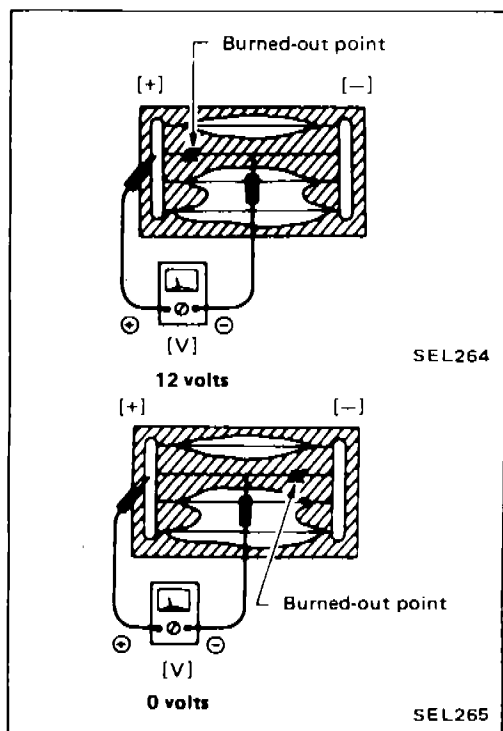
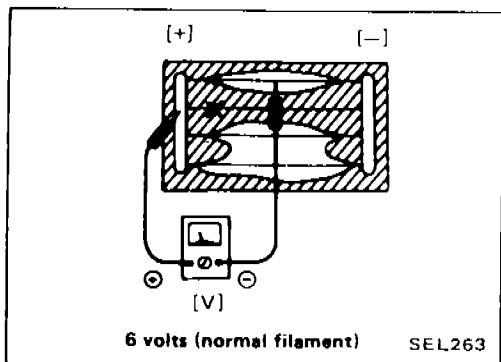

2. If a filament is burned out, circuit tester registers 0 or 12 volts.

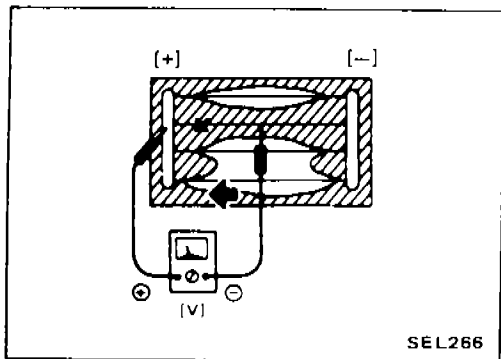

3. To locate burned out point, move probe to left and right along filament to determine point where tester needle swings abruptly.

REAR WINDOW DEFOGGER

Wiring Diagram

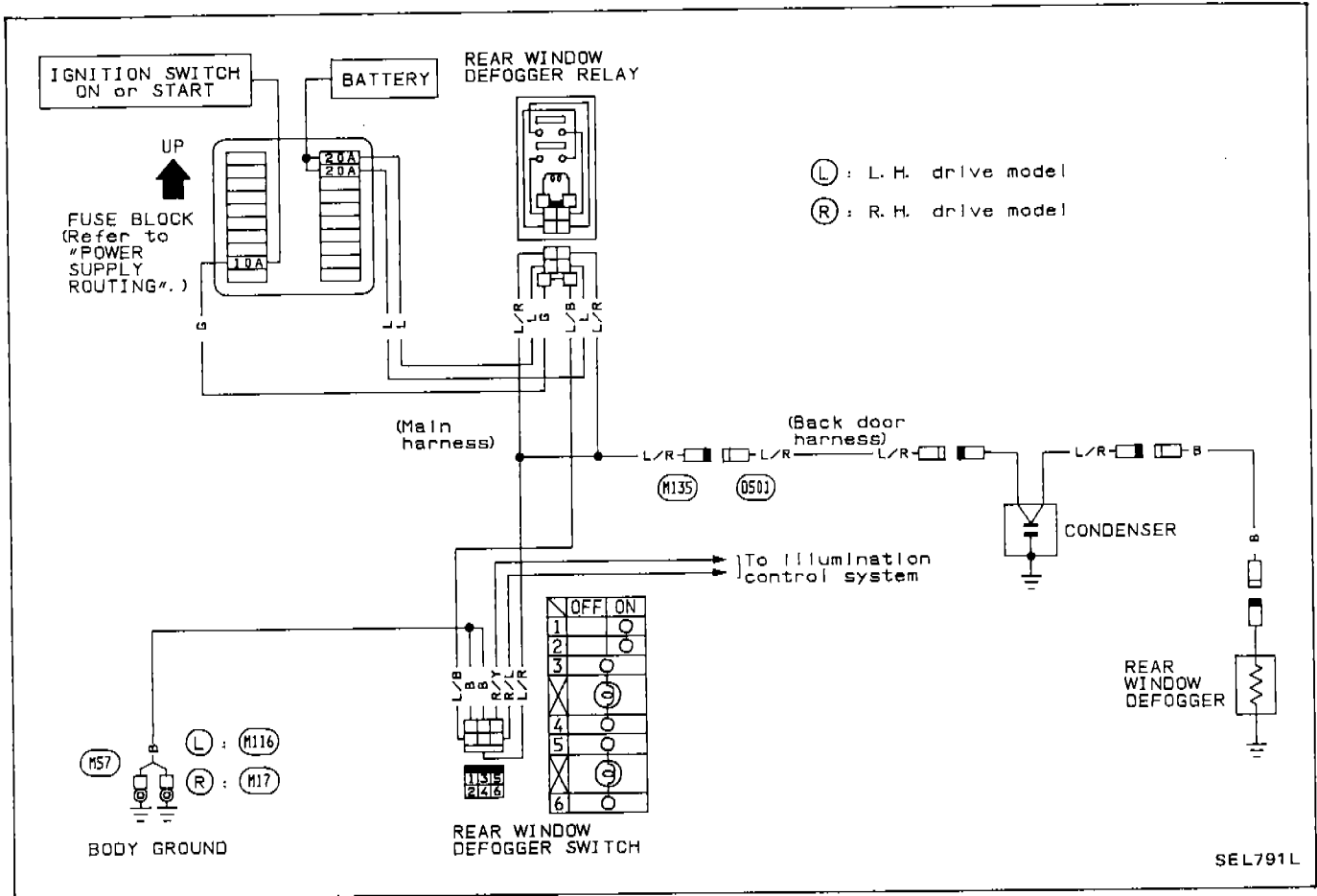

SEL791L

REAR WINDOW DEFOGGER

Filament Repair

REPAIR EQUIPMENT

1. Conductive silver composition (Dupont No. 4817 or equivalent)
2. Ruler 30 cm (11.8 in) long
3. Drawing pen
4. Heat gun
5. Alcohol
6. Cloth

REPAIRING PROCEDURE

1. Wiper broken heat wire and its surrounding area clean with a cloth dampened in alcohol.
2. Apply a small amount of conductive silver composition to tip of drawing pen.

Shake silver composition container before use.

3. Place ruler on glass along broken line. Deposit conductive silver composition on break with drawing pen. Slightly overlap existing heat wire on both sides [preferably 5 mm (0.20 in)] of the break.

4. After repair has been completed, check repaired wire for continuity. This check should be conducted 10 minutes after silver composition is deposited.

Do not touch repaired area while test is being conducted.

5. Apply a constant stream of hot air directly to the repaired area for approximately 20 minutes with a heat gun. A minimum distance of 3 cm (1.2 in) should be kept between repaired area and hot air outlet. If a heat gun is not available, let the repaired area dry for 24 hours.

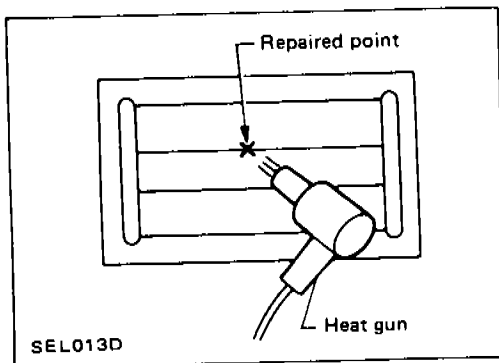
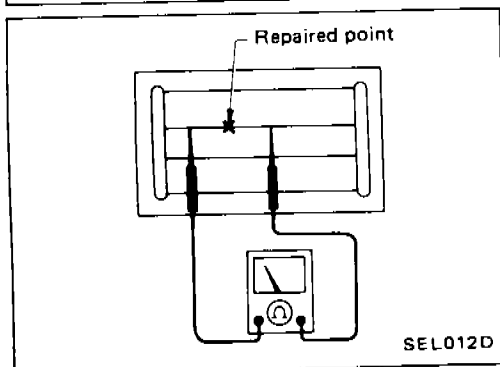
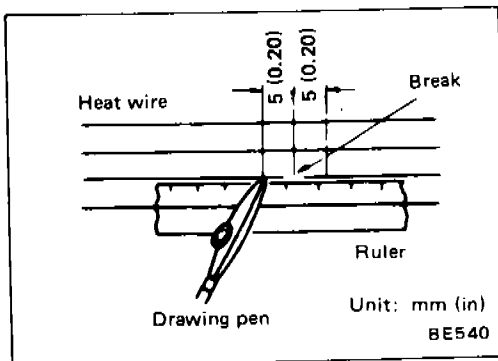

Location of Antenna

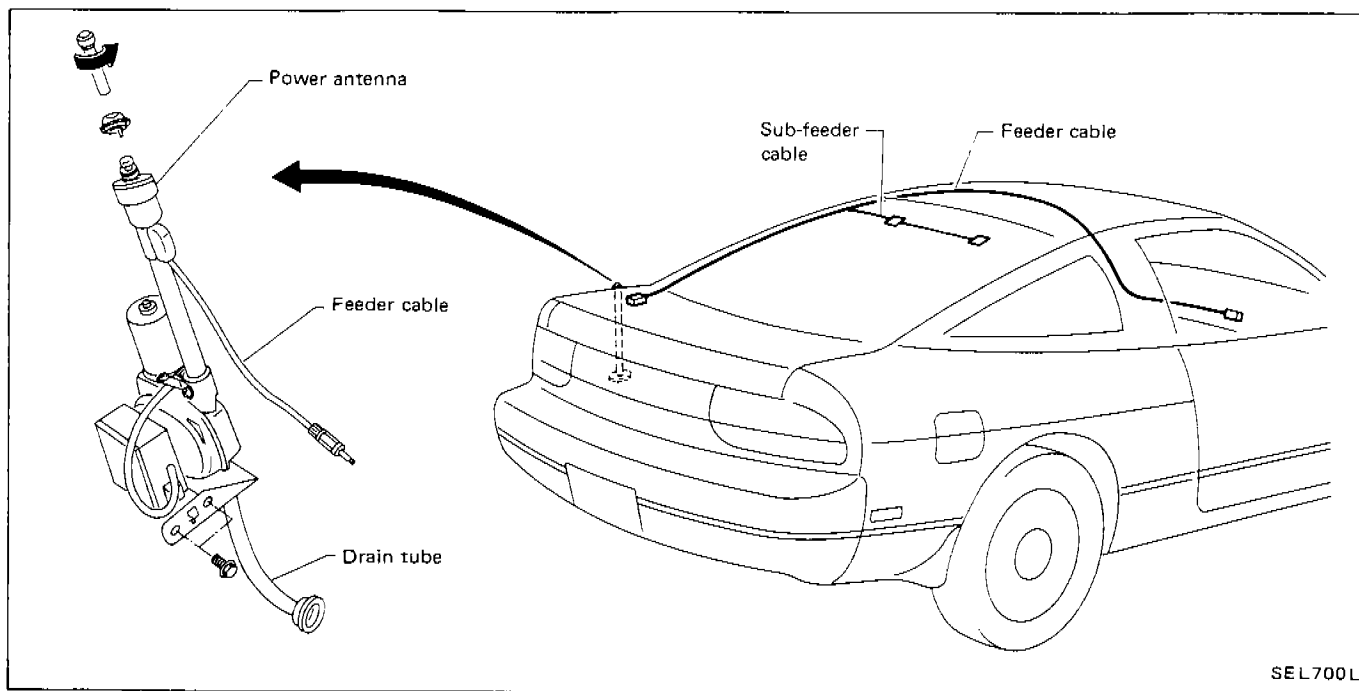

SEL700L

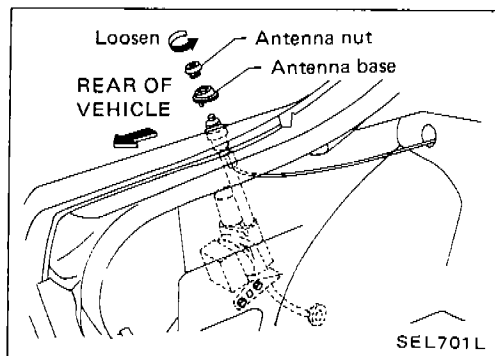

SEL701L

Antenna Rod Replacement REMOVAL

1. Remove antenna nut and antenna base.

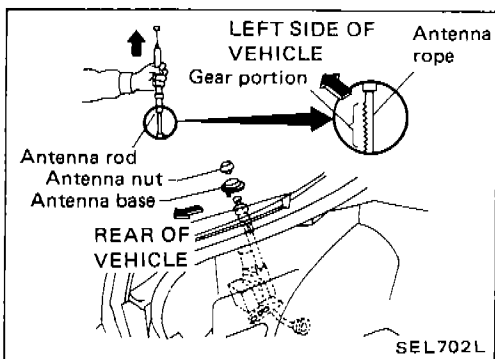

SEL702L

2. Withdraw antenna rod while raising it by operating antenna motor.

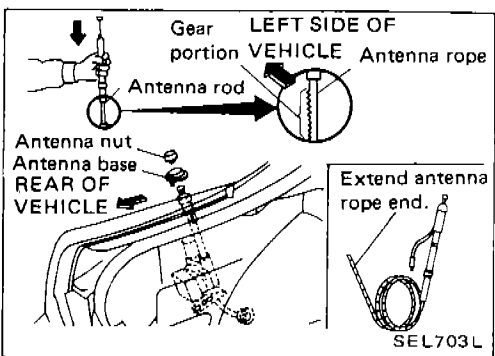

SEL703L

INSTALLATION

1. Lower antenna rod by operating antenna motor.
2. Insert gear section of antenna rope into place with it facing toward antenna motor.
3. As soon as antenna rope is wound on antenna motor, stop antenna motor. Insert antenna rod lower end into antenna motor pipe.
4. Retract antenna rod completely by operating antenna motor.
5. Install antenna nut and base.

AUDIO AND POWER ANTENNA

Power Antenna/Wiring Diagram

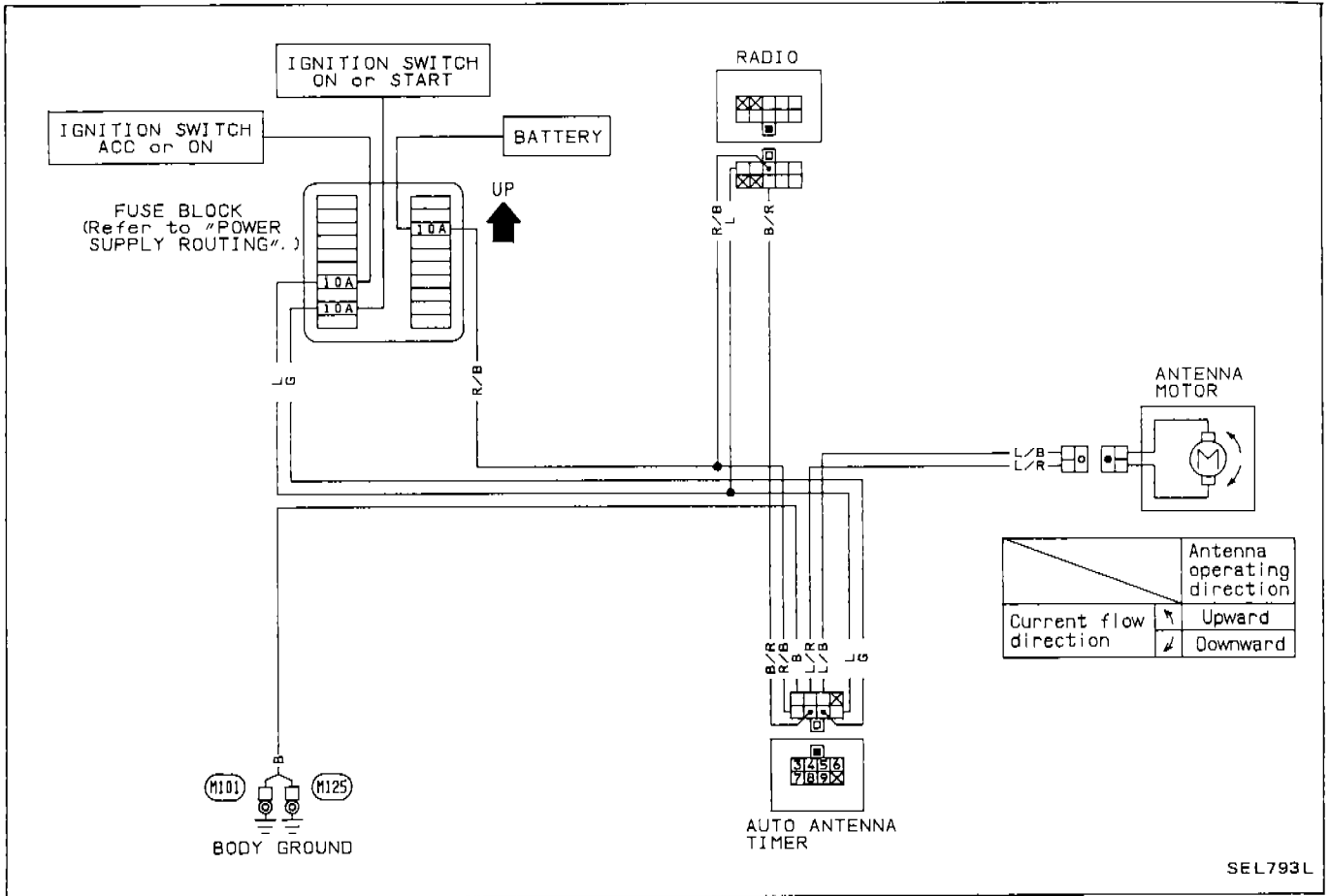

AUDIO AND POWER ANTENNA

Window Antenna Repair

ELEMENT CHECK

1. Attach probe circuit tester (in ohm range) to antenna terminal on each side.

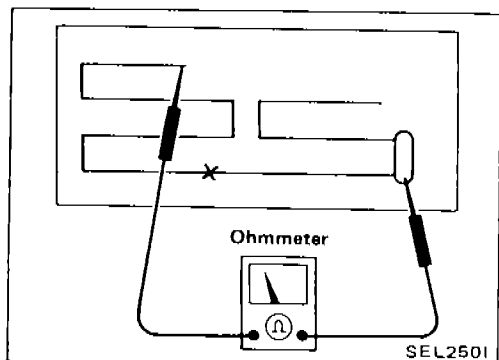

2. If an element is broken, no continuity will exist.

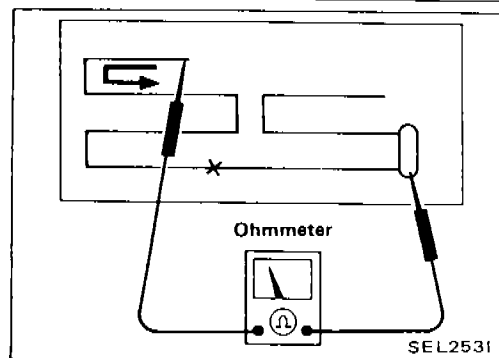
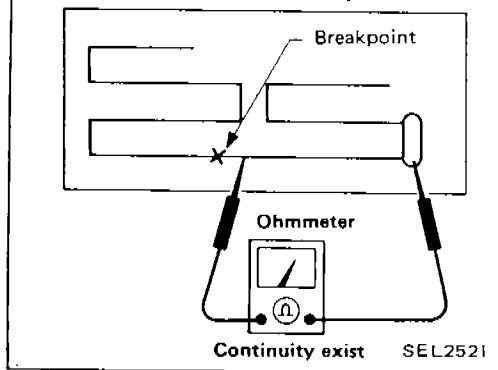
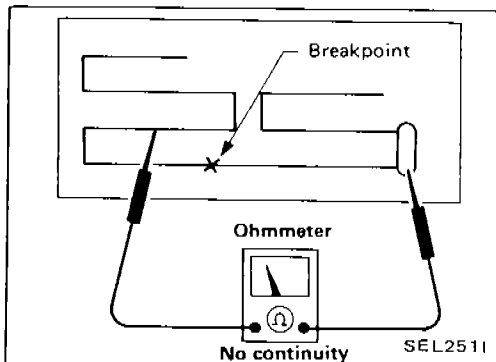

3. To locate broken point, move probe to left and right along element to determine point where tester needle swings abruptly.

ELEMENT REPAIR

Refer to "Filament Repair" of REAR WINDOW DEFOGGER.

LOCATION OF ELECTRICAL UNITS

Engine Compartment

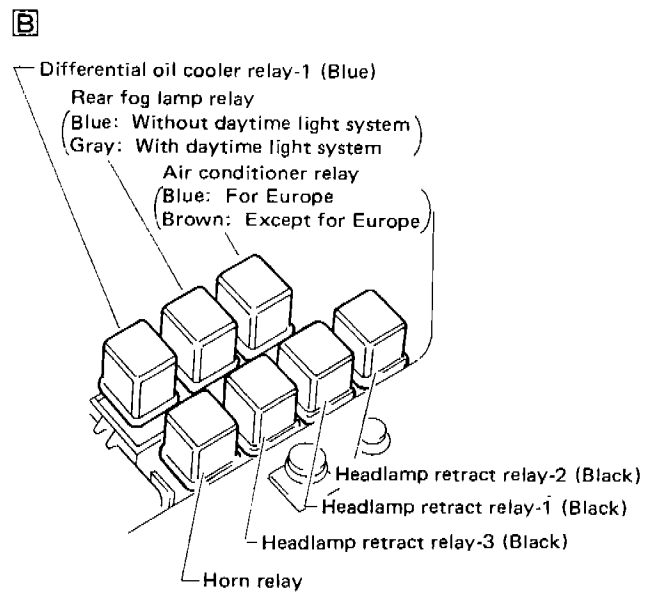
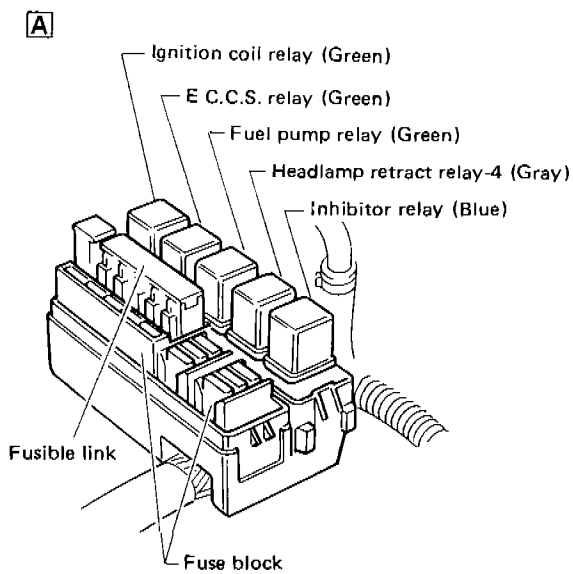
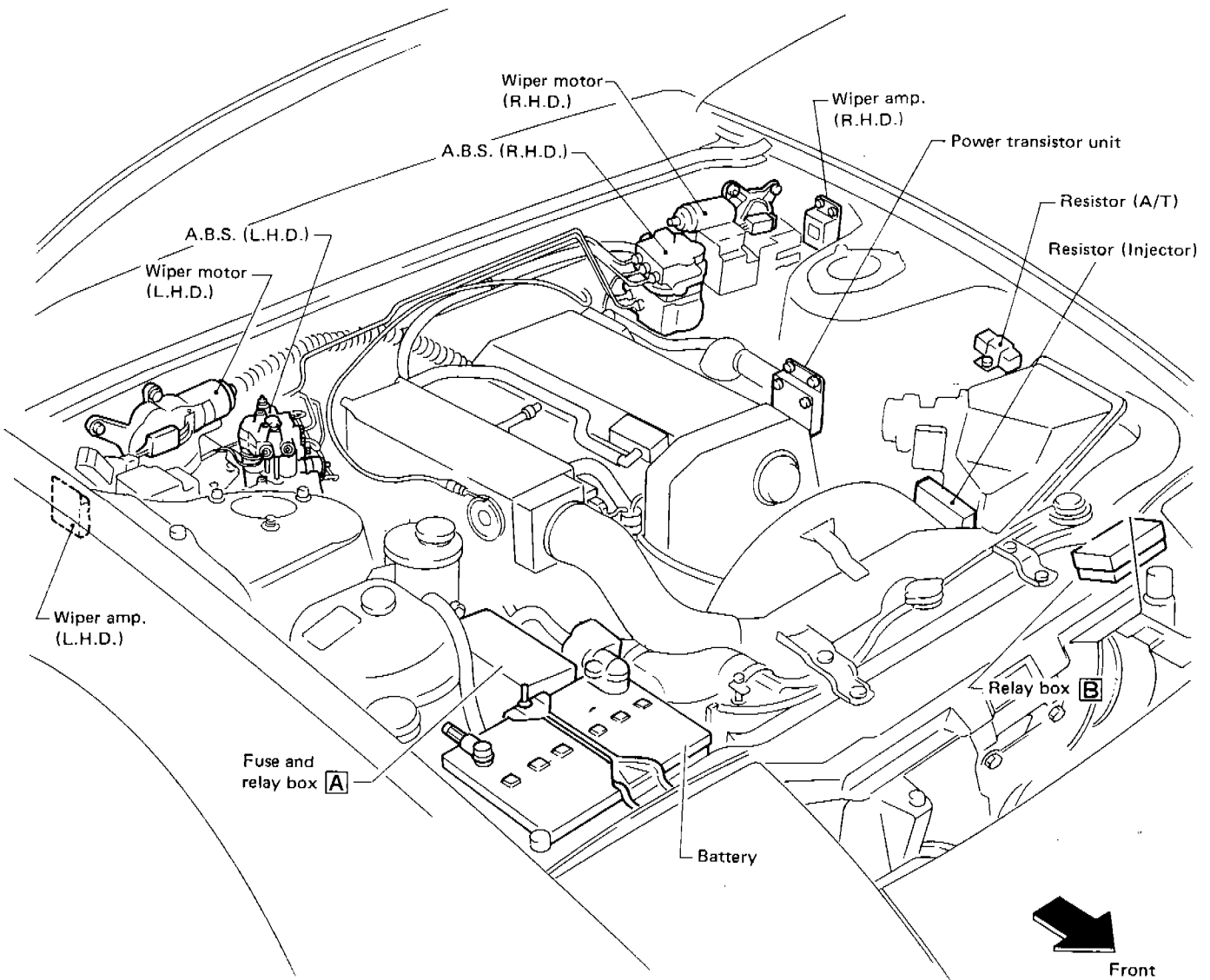

SEL705L

LOCATION OF ELECTRICAL UNITS

Passenger Compartment

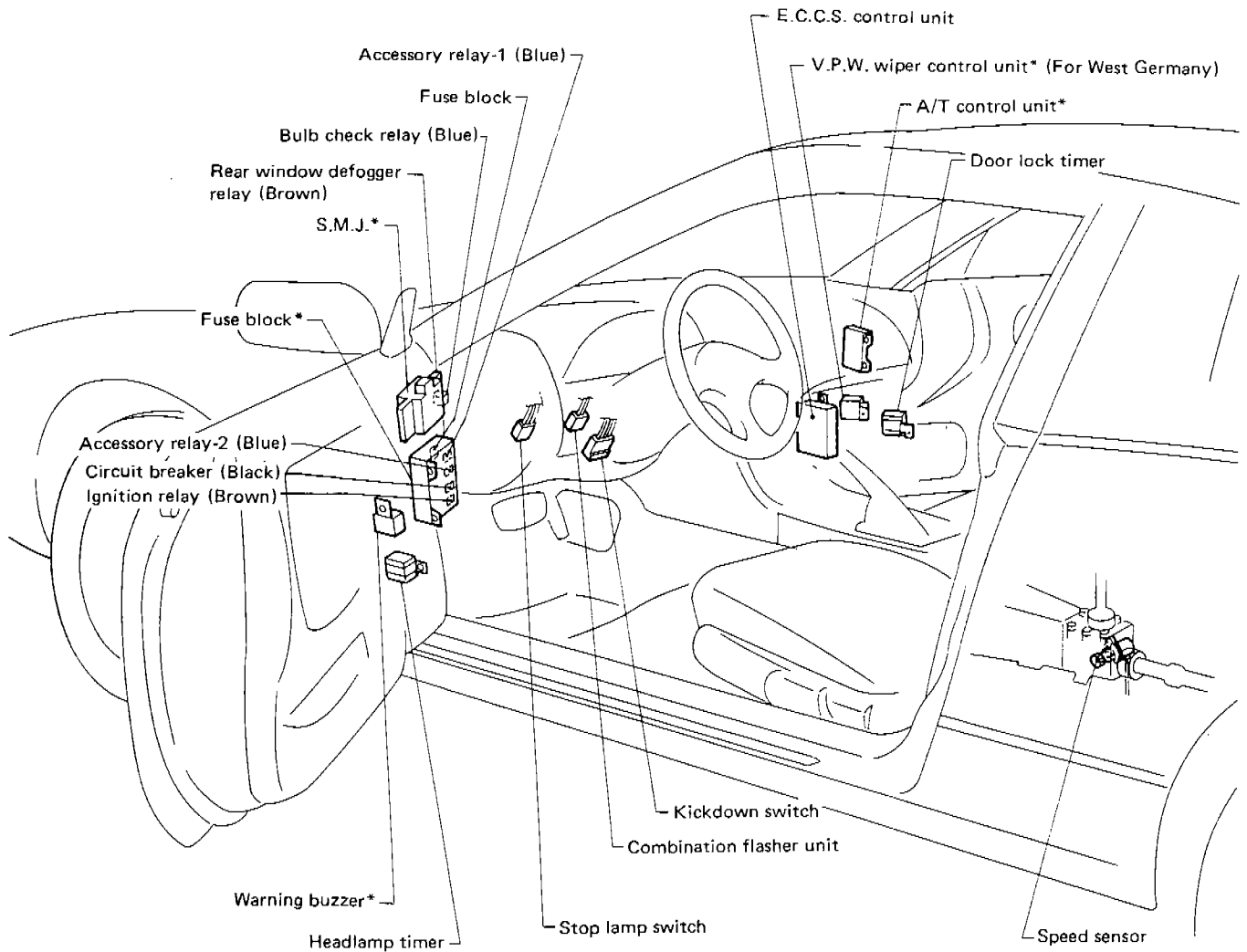

- Figure shows dashboard for L.H.D. models.
- On R.H.D. models, all side panel unit parts marked with an asterisk "*" are symmetrically located to those of L.H.D. models. However, switches and units around steering column remain in the same relative position to each other except that they have all been moved to the right side.

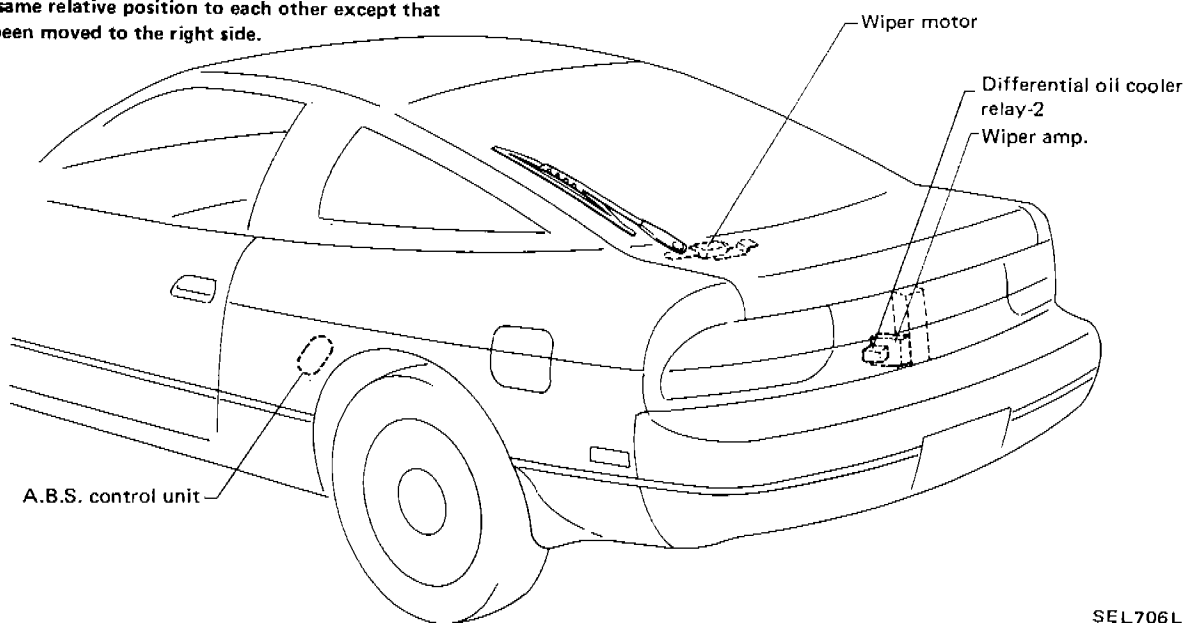

SEL706L

HARNESSES LAYOUT

Outline

L.H. DRIVE MODEL

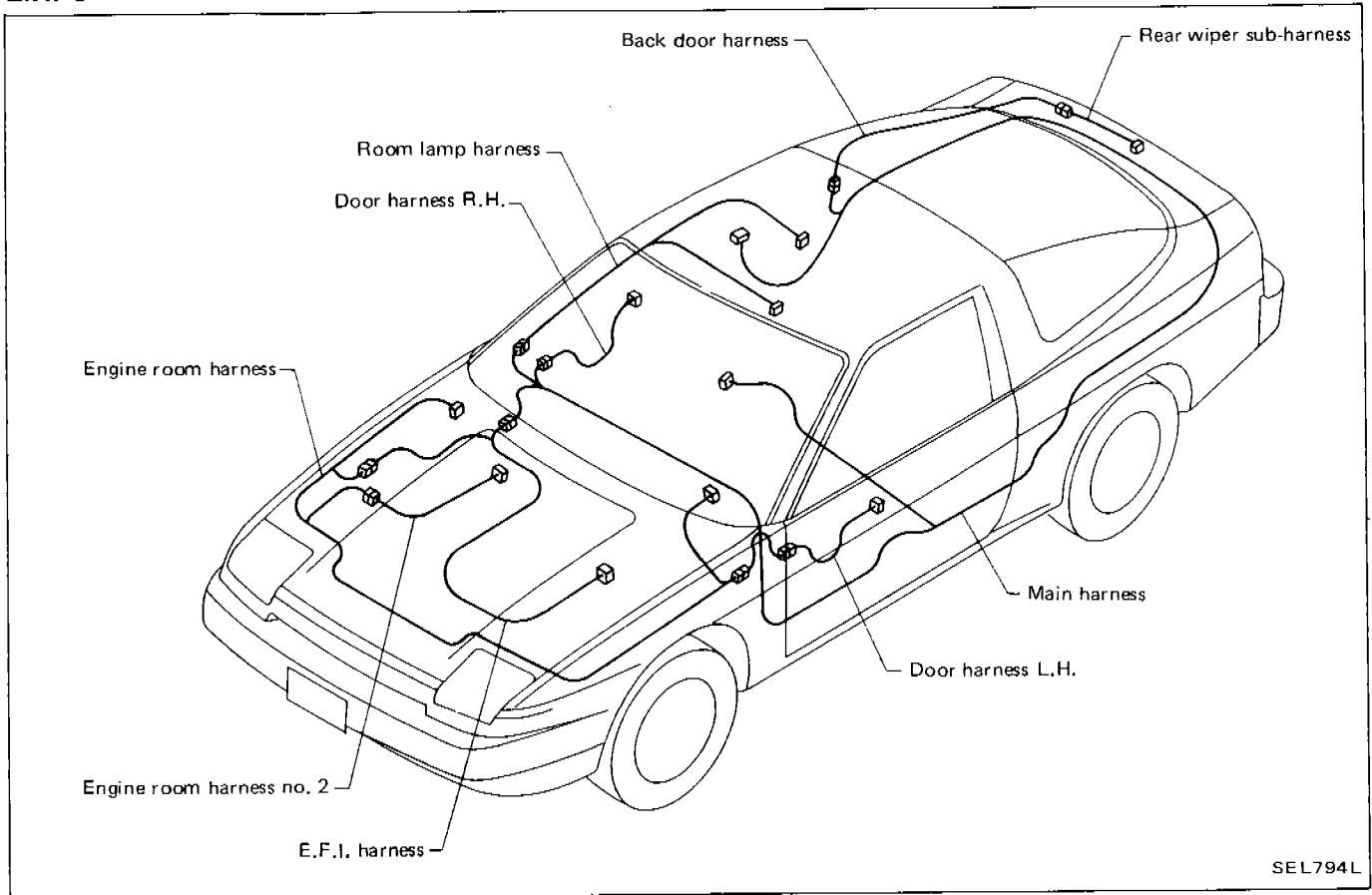

R.H. DRIVE MODEL

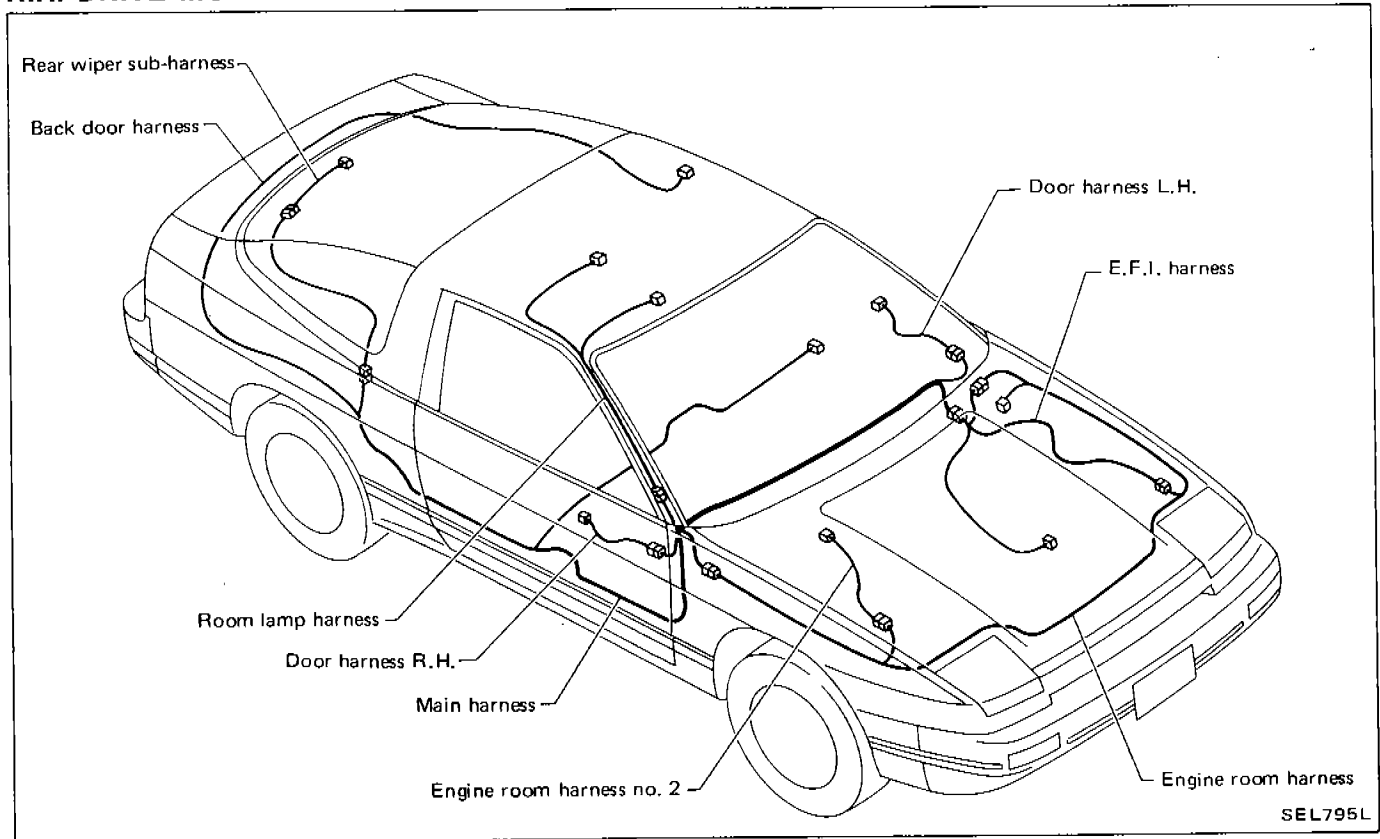

HARNESS LAYOUT

Main Harness

L.H. DRIVE MODEL

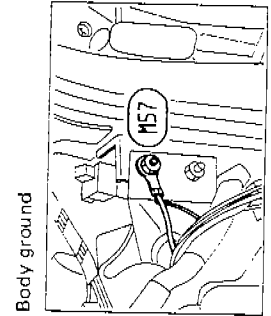
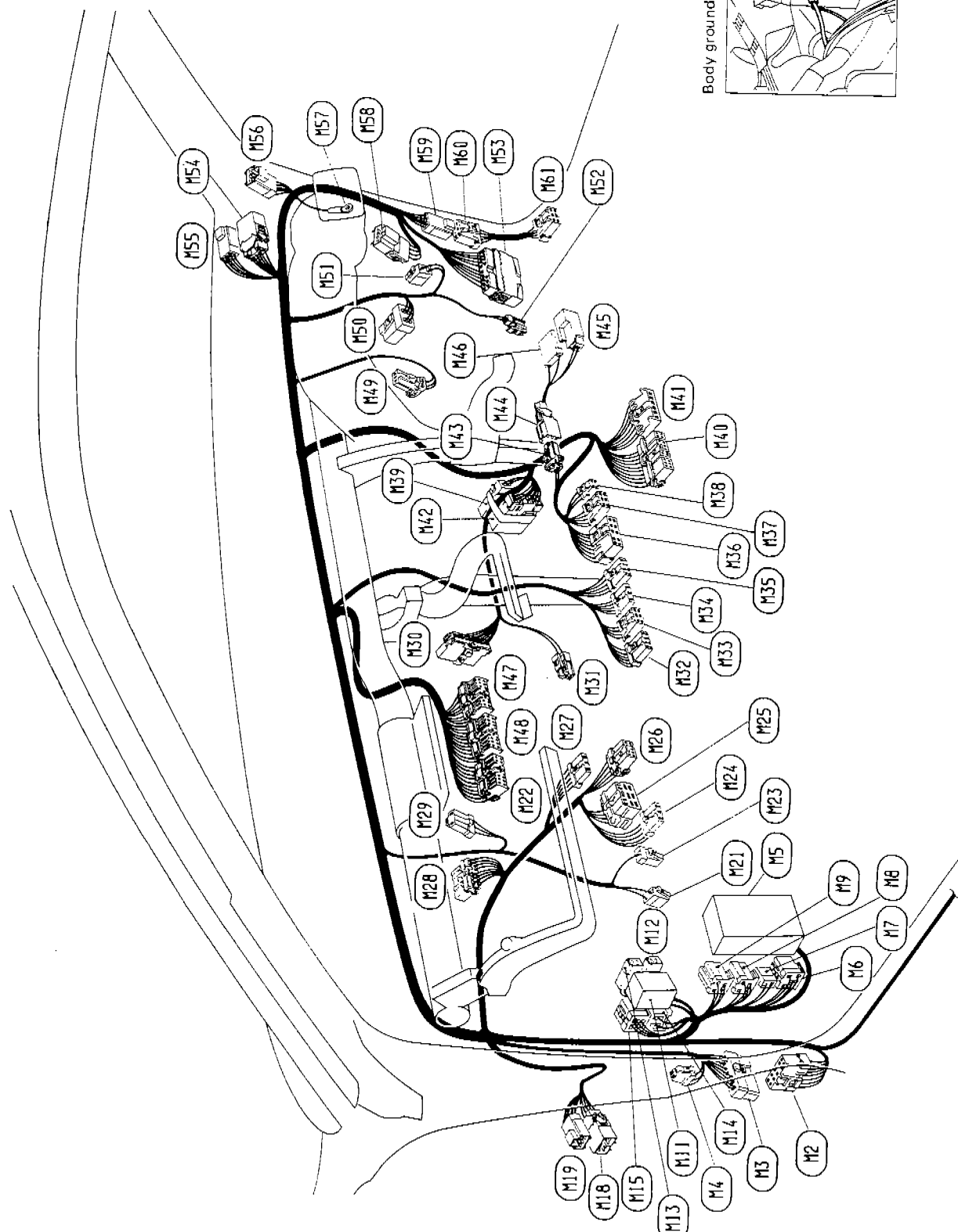

HARNESS LAYOUT

Main Harness (Cont'd)

- (72) : Headlamp timer
- (73) : Check connector
- (74) : Warning buzzer
- (75) : Fuse block
- (76) : Ignition relay
- (77) : Circuit breaker (Model with power window system)
- (78) : Accessory relay-2
- (79) : Accessory relay-1
- (E101) : To engine room harness (Blue)
- (E102) : To engine room harness (Black)
- (E103) : To engine room harness (Black)
- (714) : Bulb check relay
- (715) : Rear window defogger relay
- (718) : To door harness L.H. (01)
- (719) : To door harness L.H. (02)
- (721) : Kickdown switch (A/T model)
- (722) : Combination meter
- (723) : Stop lamp switch
- (724) : Rear fog lamp switch
- (725) : Headlamp retractor switch
- (726) : Illumination control amplifier
- (727) : Not used
- (728) : Not used
- (729) : Combination flasher unit
- (730) : Mode door motor
- (731) : Foot lamp L.H.
- (732) : Headlamp washer switch
- (733) : Rear wiper and washer switch
- (734) : Rear window defogger switch
- (735) : Hazard switch
- (736) : Radio
- (737) : Radio
- (738) : Cassette deck
- (739) : Diode (Except for Europe)
- (740) : Push control unit
- (741) : Fan switch
- (742) : Diode (For Europe)
- (743) : To sub-harness (744)
- (744) : To main harness (743)
- (745) : Glove box lamp
- (746) : Glove box lamp switch
- (747) : Combination meter
- (748) : Combination meter
- (749) : Thermo control amplifier

- (750) : Heater resistor
- (751) : Blower motor
- (752) : Foot lamp R.H.
- (753) : To E.F.I. harness (E1)
- (754) : To door harness R.H. (010)
- (755) : To door harness R.H. (0102)
- (756) : To room lamp harness (761)
- (757) : Body ground
- (758) : Intake door motor
- (759) : To sub-harness (760)
- (760) : To main harness (759)
- (761) : Door lock timer

Diode (742)

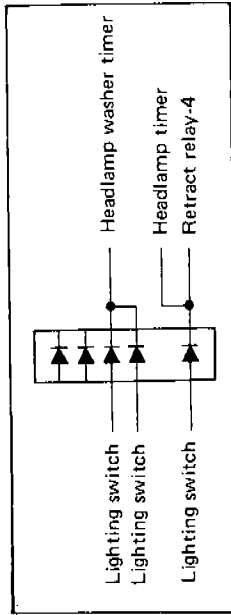

Diode (739)

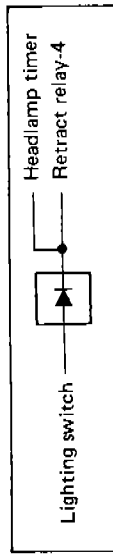

HARNESS LAYOUT

Main Harness (Cont'd)

L.H. DRIVE MODEL

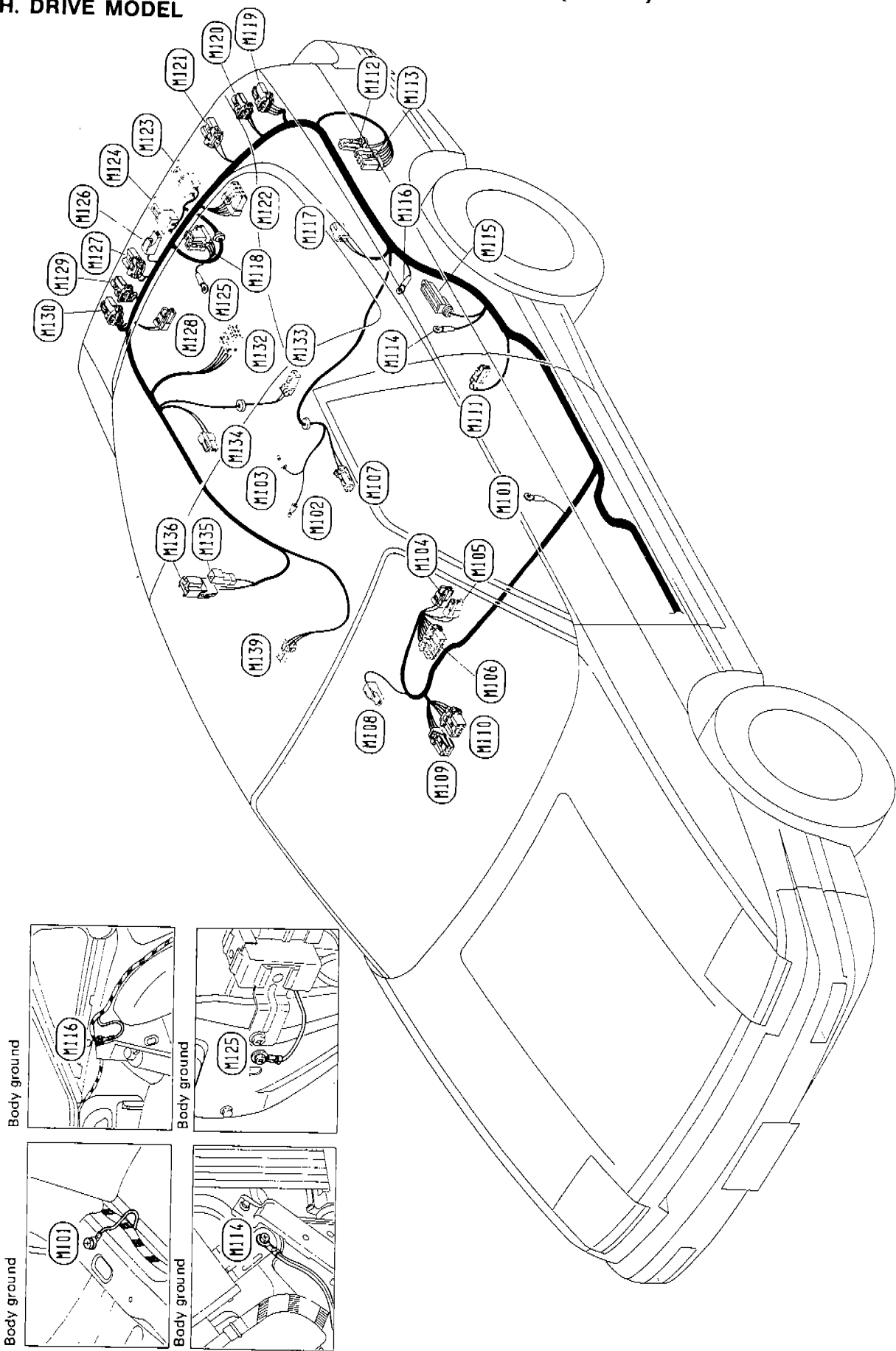

HARNES LAYOUT

Main Harness (Cont'd)

(1119) : Rear combination lamp L.H.
(1120) : Rear combination lamp L.H.
(1121) : Back-up lamp L.H.
(1122) : Rear wiper amplifier
(1123) : License lamp L.H.
(1124) : License lamp R.H.
(1125) : Body ground
(1126) : Luggage room lamp switch
(1127) : Back-up lamp R.H.
(1128) : Luggage room lamp
(1129) : Rear combination lamp R.H.
(1130) : Rear combination lamp R.H.
(1132) : Fuel tank gauge unit
(1133) : Rear brake skid sensor
(1134) : Rear speaker R.H.
(1135) : To back door harness (0511)
(1136) : To back door harness (0540)
(1139) : Door switch R.H.

(1101) : Body ground
(1102) : Differential oil temperature sensor
(1103) : Differential oil temperature switch
(1104) : Ash tray illumination
(1105) : Cigarette lighter
(1106) : Door mirror control switch
(1107) : Differential oil cooler pump
(1108) : Parking brake switch
(1109) : A/T device (A/T illumination and O.D. control switch) (A/T model)
(1110) : Not used
(1111) : Door switch L.H.
(1112) : Power antenna motor
(1113) : Power antenna timer
(1114) : Body ground
(1115) : 4-wheel skid control unit
(1116) : Body ground
(1117) : Rear speaker L.H.
(1118) : Differential oil cooler relay-2

HARNESS LAYOUT

Main Harness (Cont'd)

R.H. DRIVE MODEL

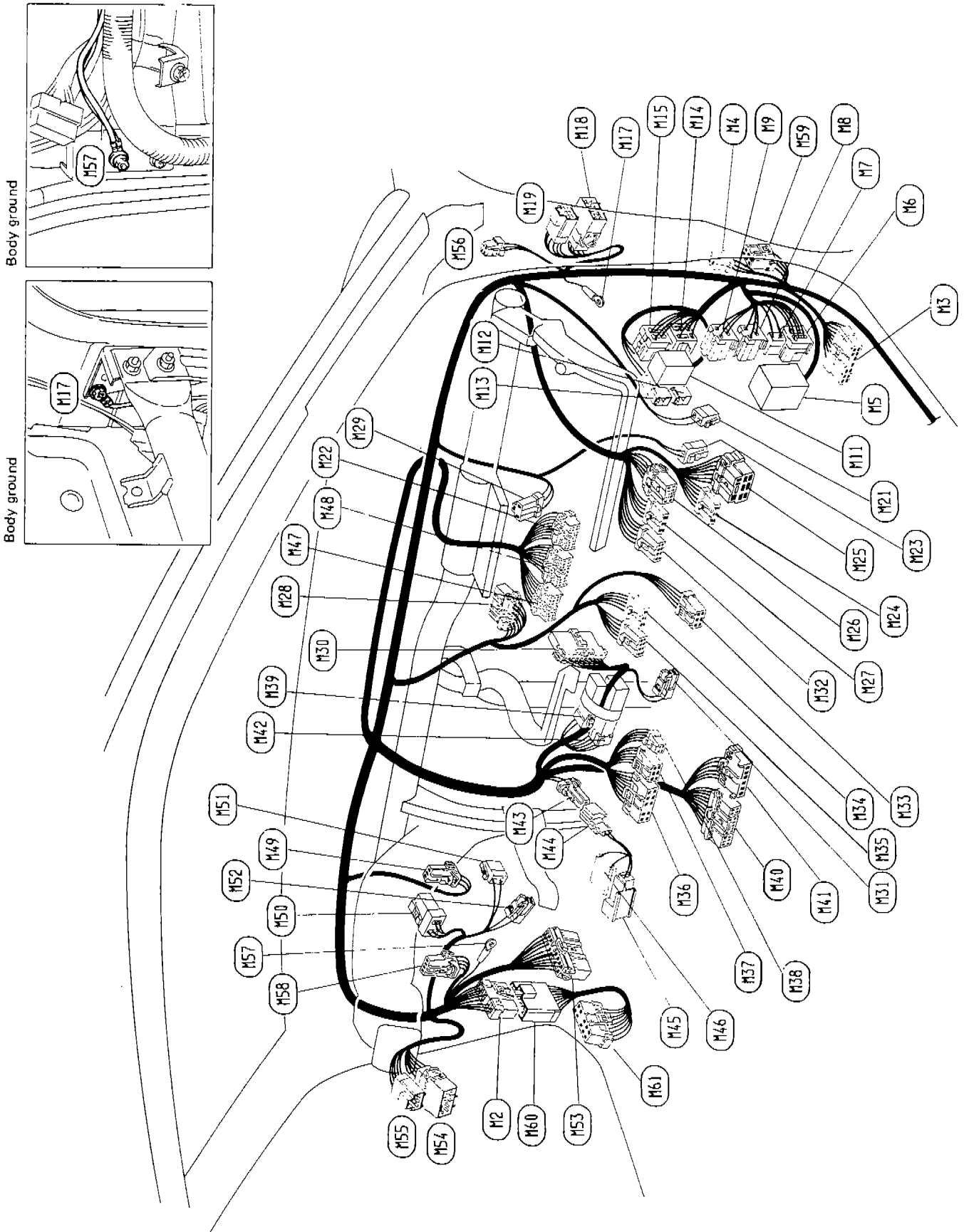

HARNES LAYOUT

Main Harness (Cont'd)

- (R2) : To sub-harness (R40)
- (R3) : Check connector
- (R4) : Warning buzzer
- (R5) : Fuse block
- (R6) : Ignition relay
- (R7) : Circuit breaker (Model with power window system)
- (R8) : Accessory relay-2
- (R9) : Accessory relay-1
- (R10) : To engine room harness (E101) (Blue)
- (R11) : To engine room harness (E102) (Black)
- (R12) : To engine room harness (E103)
- (R13) : Bulb check relay
- (R14) : Rear window defogger relay
- (R15) : Body ground
- (R16) : To door harness R.H. (011)
- (R17) : To door harness R.H. (012)
- (R18) : Kickdown switch (A/T model)
- (R19) : Combination meter
- (R20) : Stop lamp switch
- (R21) : Rear fog lamp switch
- (R22) : Headlamp retractor switch
- (R23) : Illumination control amplifier
- (R24) : Not used
- (R25) : Not used
- (R26) : Combination flasher unit
- (R27) : Mode door motor
- (R28) : Foot lamp L.H.
- (R29) : Headlamp washer switch
- (R30) : Rear wiper and washer switch
- (R31) : Rear window defogger switch
- (R32) : Hazard switch
- (R33) : Radio
- (R34) : Radio
- (R35) : Cassette deck
- (R36) : Diode (Except for Europe)
- (R37) : Push control unit
- (R38) : Fan switch
- (R39) : Diode (For Europe)
- (R40) : To sub-harness (R44)
- (R41) : To main harness (R43)
- (R42) : Glove box lamp
- (R43) : Glove box lamp switch
- (R44) : Combination meter
- (R45) : Combination meter
- (R46) : Thermo control amplifier

- (R50) : Heater resistor
- (R51) : Blower motor
- (R52) : Foot lamp R.H.
- (R53) : To E.F.I. harness (F1)
- (R54) : To door harness L.H. (011)
- (R55) : To door harness L.H. (012)
- (R56) : To room lamp harness (R1)
- (R57) : Body ground
- (R58) : Intake door motor
- (R59) : Door lock timer
- (R60) : To main harness (R2)
- (R61) : Headlamp timer

Diode (R42)

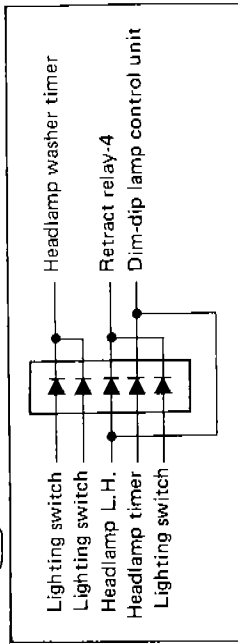

Diode (R39)

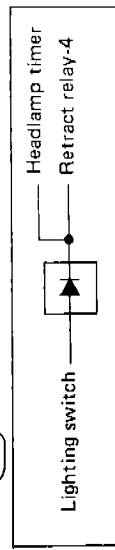

HARNESS LAYOUT

Main Harness (Cont'd)

R.H. DRIVE MODEL

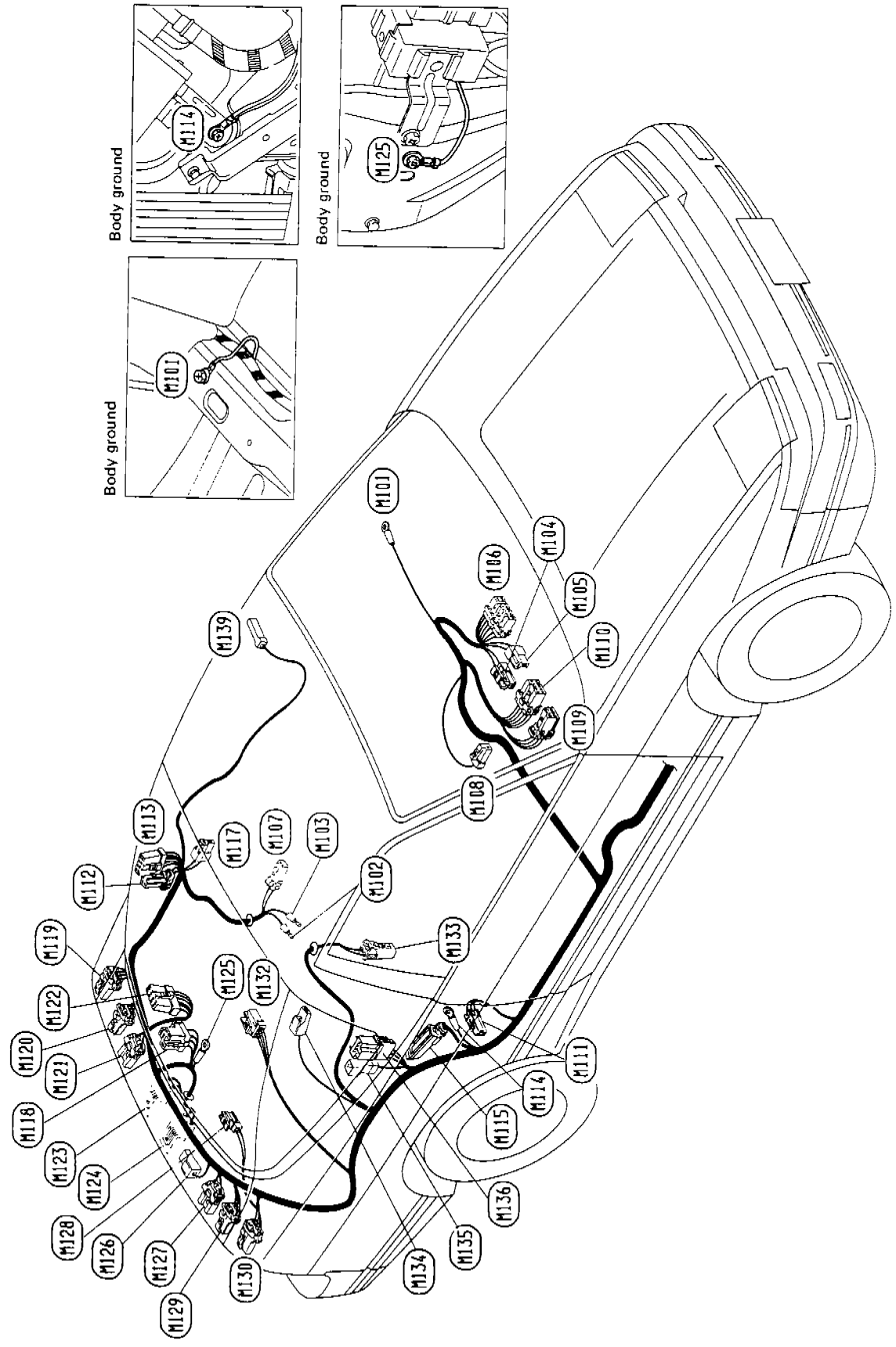

HARNES LAYOUT

Main Harness (Cont'd)

- (1120) : Rear combination lamp L. H.
- (1121) : Back-up lamp L. H.
- (1122) : Rear wiper amplifier
- (1123) : License lamp L. H.
- (1124) : License lamp R. H.
- (1125) : Body ground
- (1126) : Luggage room lamp switch
- (1127) : Back-up lamp R. H.
- (1128) : Luggage room lamp
- (1129) : Rear combination lamp R. H.
- (1130) : Rear combination lamp R. H.
- (1132) : Fuel tank gauge unit
- (1133) : Rear brake skid sensor
- (1134) : Rear speaker R. H.
- (1135) : To back door harness (050)
- (1136) : To back door harness (0502)
- (1139) : Door switch L. H.

- (1101) : Body ground
- (1102) : Differential oil temperature sensor
- (1103) : Differential oil temperature switch
- (1105) : Ash tray illumination
- (1105) : Cigarette lighter
- (1106) : Door mirror control switch
- (1107) : Differential oil cooler pump
- (1108) : Parking brake switch
- (1109) : A/T device (A/T illumination and O.D. control switch) (A/T model)
- (1110) : Not used
- (1111) : Door switch R. H.
- (1112) : Power antenna motor
- (1113) : Power antenna timer
- (1114) : Body ground
- (1115) : 4-wheel skid control unit
- (1117) : Rear speaker L. H.
- (1118) : Differential oil cooler relay-2
- (1119) : Rear combination lamp L. H.

HARNES LAYOUT

Room Lamp Harness

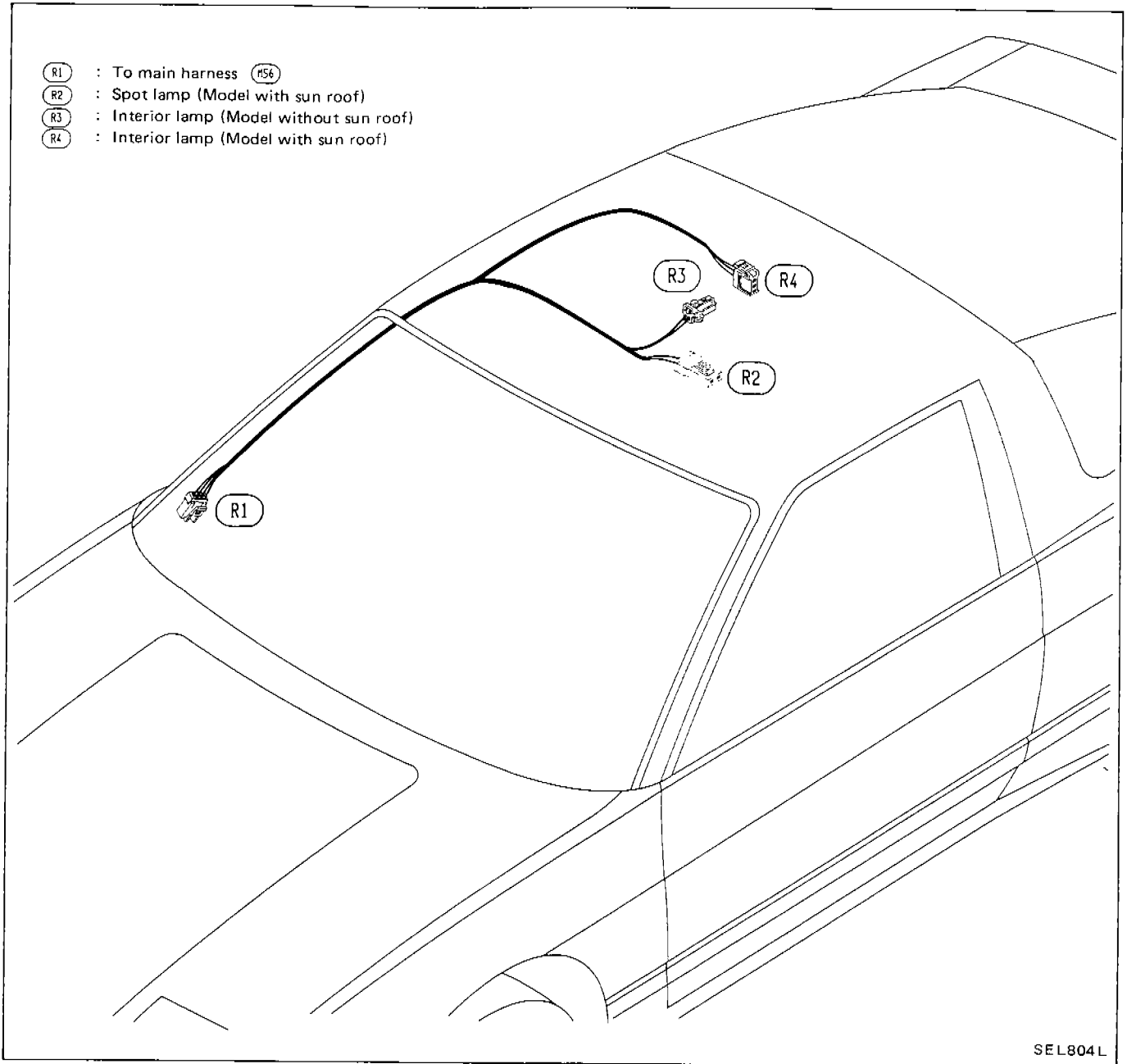

SEL804L

HARNESS LAYOUT

Door Harness L.H.

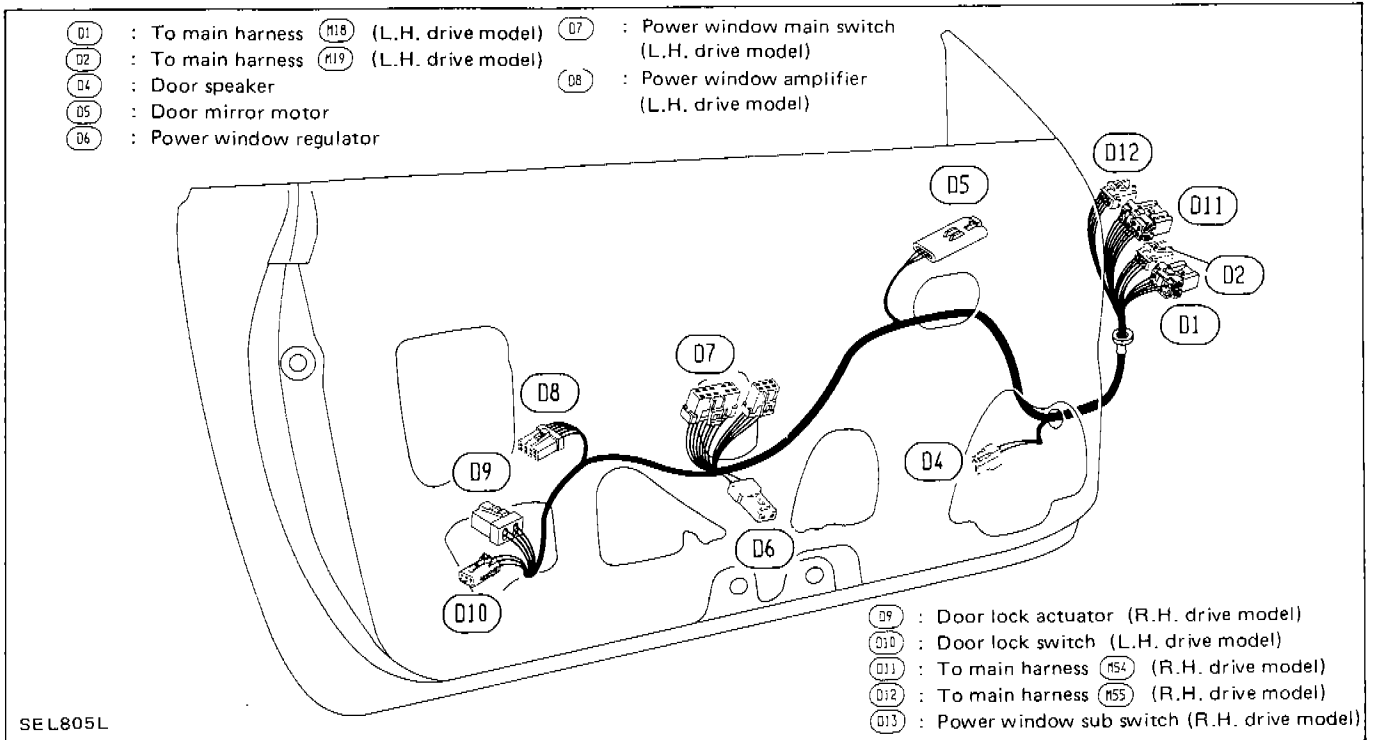

Door Harness R.H.

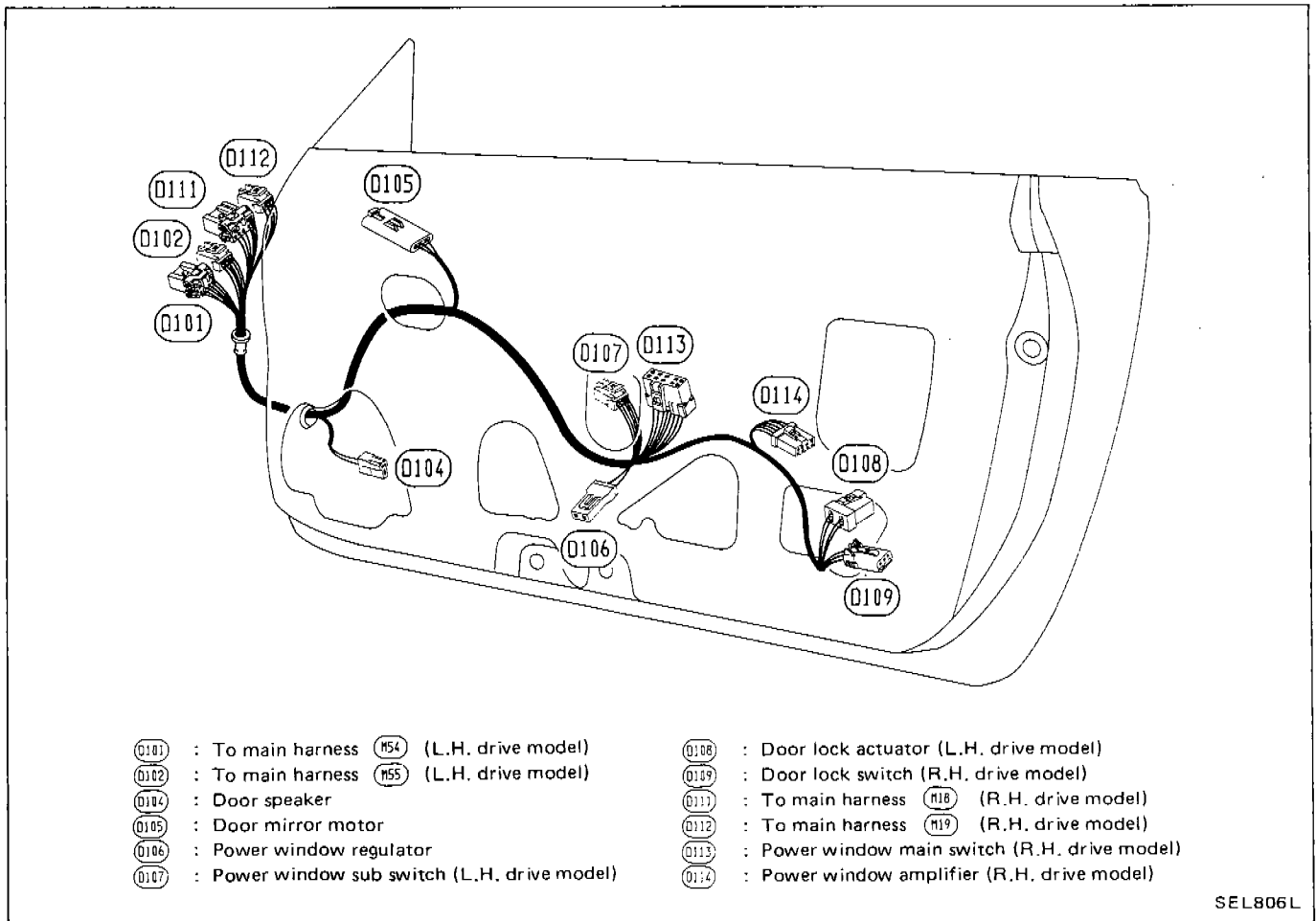

HARNESS LAYOUT

Engine Room Harness

L.H. DRIVE MODEL



HARNES LAYOUT

Engine Room Harness (Cont'd)

- (E1) : Windshield wiper motor
- (E2) : Windshield wiper amplifier
- (E3) : Side turn signal lamp R.H.
- (E4) : Anti-skid brake actuator
- (E5) : Rear washer motor
- (E6) : Front washer motor
- (E7) : Washer fluid level switch
- (E8) : To E.F.I. harness (F8) (White)
- (E9) : To E.F.I. harness (F9) (Gray)
- (E10) : To E.F.I. harness (F10) (Brown)
- (E11) : To engine room harness no. 2 (E201) (M/T model)
- (E12) : Inhibitor switch (A/T model)
- (E13) : Revolution sensor (A/T model)
- (E14) : Inhibitor switch (A/T model) (Gray)
- (E15) : To solenoid valve sub-harness (A/T model) (Brown)
- (E16) : Relay box (Refer to page EL-81.)
- (E17) : To engine room harness no. 2 (E202) (A/T model)
- (E18) : To engine room harness no. 2 (E203)
- (E19) : To engine room harness no. 2 (E204)
- (E20) : Body ground
- (E21) : To engine room harness no.2 (E205) (M/T model)
- (E22) : Battery
- (E23) : Battery
- (E24) : Body ground
- (E25) : Daytime light control unit
- (E26) : Headlamp washer amplifier
- (E27) : Headlamp washer motor

- (E28) : Not used
- (E29) : Headlamp R.H.
- (E30) : Headlamp motor R.H.
- (E31) : Front combination lamp R.H.
- (E32) : Daytime light R.H.
- (E33) : Horn-high
- (E34) : Condenser fan motor
- (E35) : Horn-low
- (E36) : Headlamp motor L.H.
- (E37) : Headlamp L.H.
- (E38) : Daytime light L.H.
- (E39) : Front combination lamp L.H.
- (E40) : Dual-pressure switch
- (E41) : Body ground
- (E42) : Relay box (Refer to page EL-81.)
- (E43) : Dropping resistor (A/T model)
- (E44) : Compressor
- (E45) : Front brake skid sensor L.H.
- (E46) : Power transistor unit
- (E47) : Brake fluid level switch
- (E48) : Pressure regulator control solenoid valve
- (E49) : Body ground for front brake skid sensor L.H.
- (E50) : V.P.W. wiper motor
- (E51) : Side turn signal lamp L.H.
- (E52) : To engine room harness (E28)

HARNESS LAYOUT

Engine Room Harness (Cont'd)

L.H. DRIVE MODEL

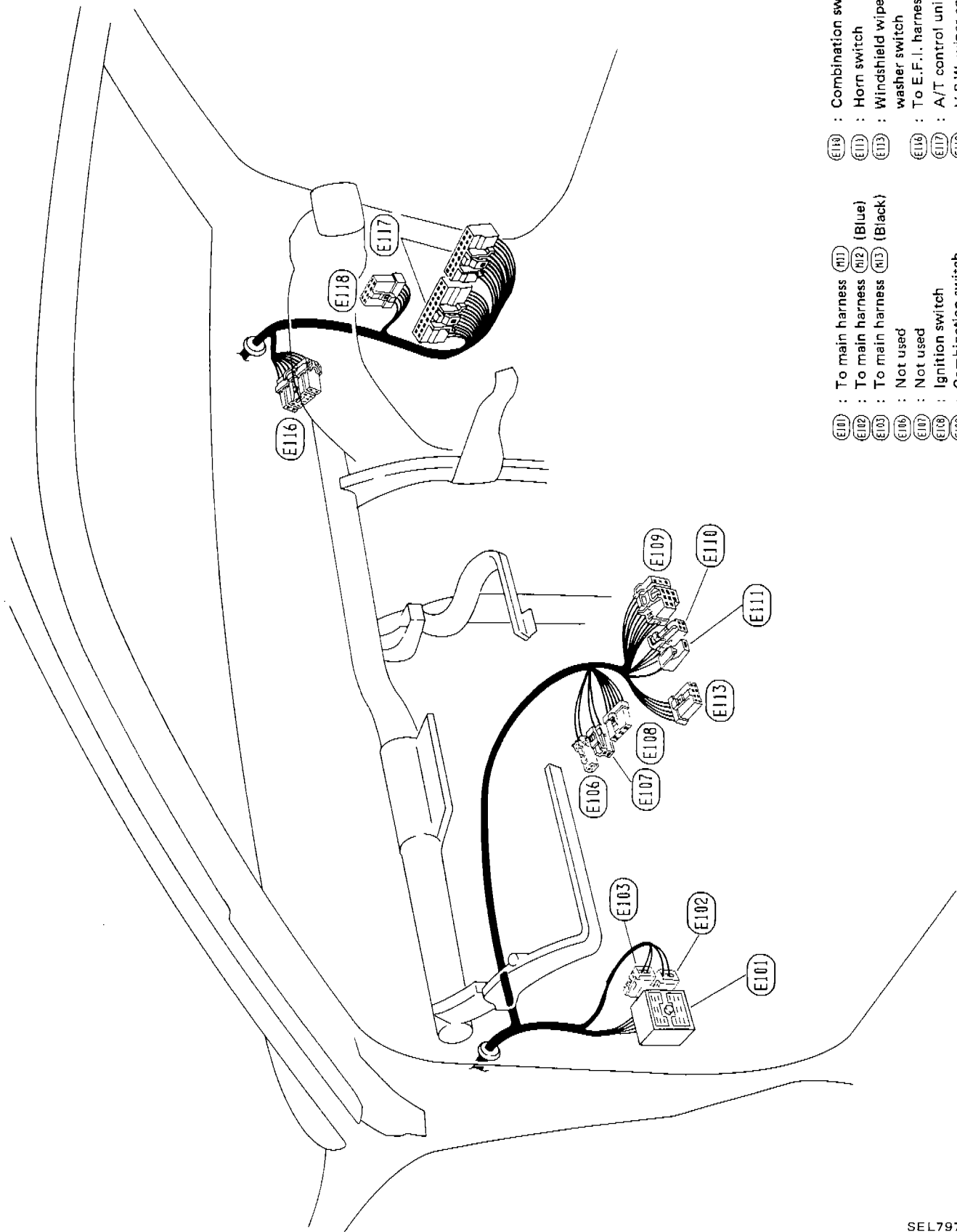

- (E101) : To main harness (H11)
- (E102) : To main harness (H12) (Blue)
- (E103) : To main harness (H13) (Black)
- (E106) : Not used
- (E107) : Not used
- (E108) : Ignition switch
- (E109) : Combination switch
- (E110) : To main harness (H11)
- (E111) : To main harness (H12) (Blue)
- (E112) : Horn switch
- (E113) : Windshield wiper and washer switch
- (E116) : To E.F.I. harness (F3)
- (E117) : A/T control unit
- (E118) : Combination switch
- (E119) : V.P.W. wiper control unit

HARNES LAYOUT

NOTE

EL-97

HARNESS LAYOUT

Engine Room Harness (Cont'd)

R.H. DRIVE MODEL

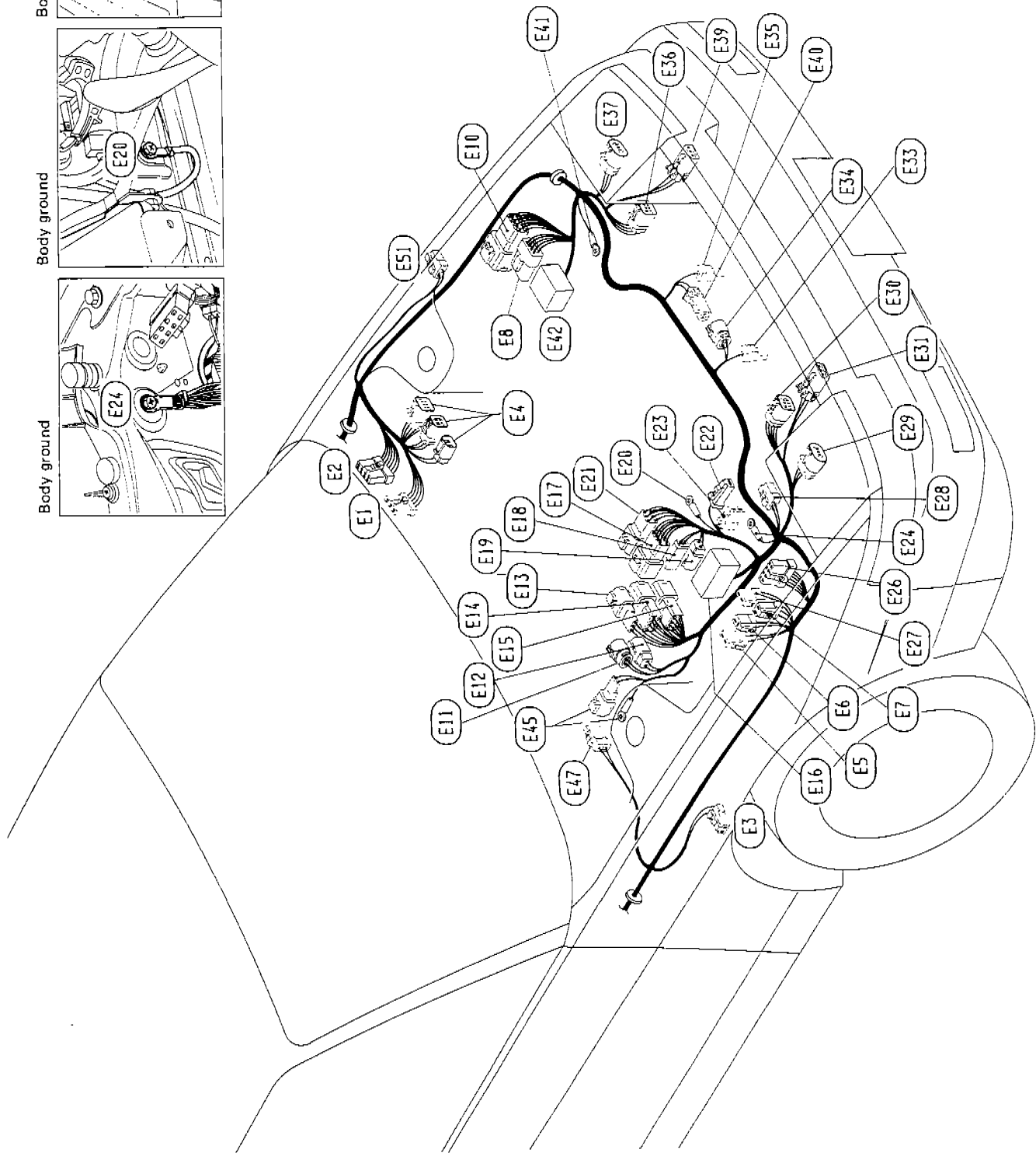
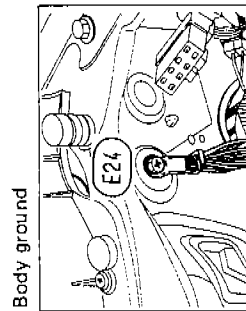
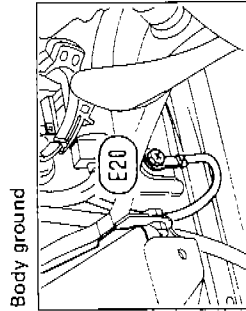
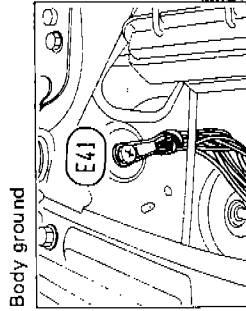

HARNES LAYOUT

Engine Room Harness (Cont'd)

- E1 : Windshield wiper motor
- E2 : Windshield wiper amplifier
- E3 : Side turn signal lamp R.H.
- E4 : Anti-skid brake actuator
- E5 : Rear washer motor
- E6 : Front washer motor
- E7 : Washer fluid level switch
- E8 : To E.F.I. harness (E8) (White)
- E10 : To E.F.I. harness (E10) (Brown)
- E11 : To engine room harness no. 2 (E201) (M/T model)
- E12 : Inhibitor switch (A/T model)
- E13 : Revolution sensor (A/T model)
- E14 : Inhibitor switch (A/T model) (Gray)
- E15 : To solenoid valve sub-harness (A/T model) (Brown)
- E16 : Relay box (Refer to page EL-81.)
- E17 : To engine room harness no. 2 (E202) (A/T model)
- E18 : To engine room harness no. 2 (E203)
- E19 : To engine room harness no. 2 (E204)
- E20 : Body ground
- E21 : To engine room harness no.2 (E205) (M/T model)
- E22 : Battery
- E23 : Battery
- E24 : Body ground
- E26 : Headlamp washer amplifier
- E27 : Headlamp washer motor
- E28 : Not used
- E29 : Headlamp R.H.
- E30 : Headlamp motor R.H.
- E31 : Front combination lamp R.H.
- E33 : Horn-high
- E34 : Condenser fan motor
- E35 : Horn-low
- E36 : Headlamp motor L.H.
- E37 : Headlamp L.H.
- E39 : Front combination lamp L.H.
- E40 : Dual-pressure switch
- E41 : Body ground
- E42 : Relay box (Refer to page EL-81.)
- E45 : Front brake skid sensor R.H.
- E47 : Brake fluid level switch
- E51 : Side turn signal lamp L.H.
- E52 : To engine room harness (E28)

HARNESS LAYOUT

Engine Room Harness (Cont'd)

R.H. DRIVE MODEL

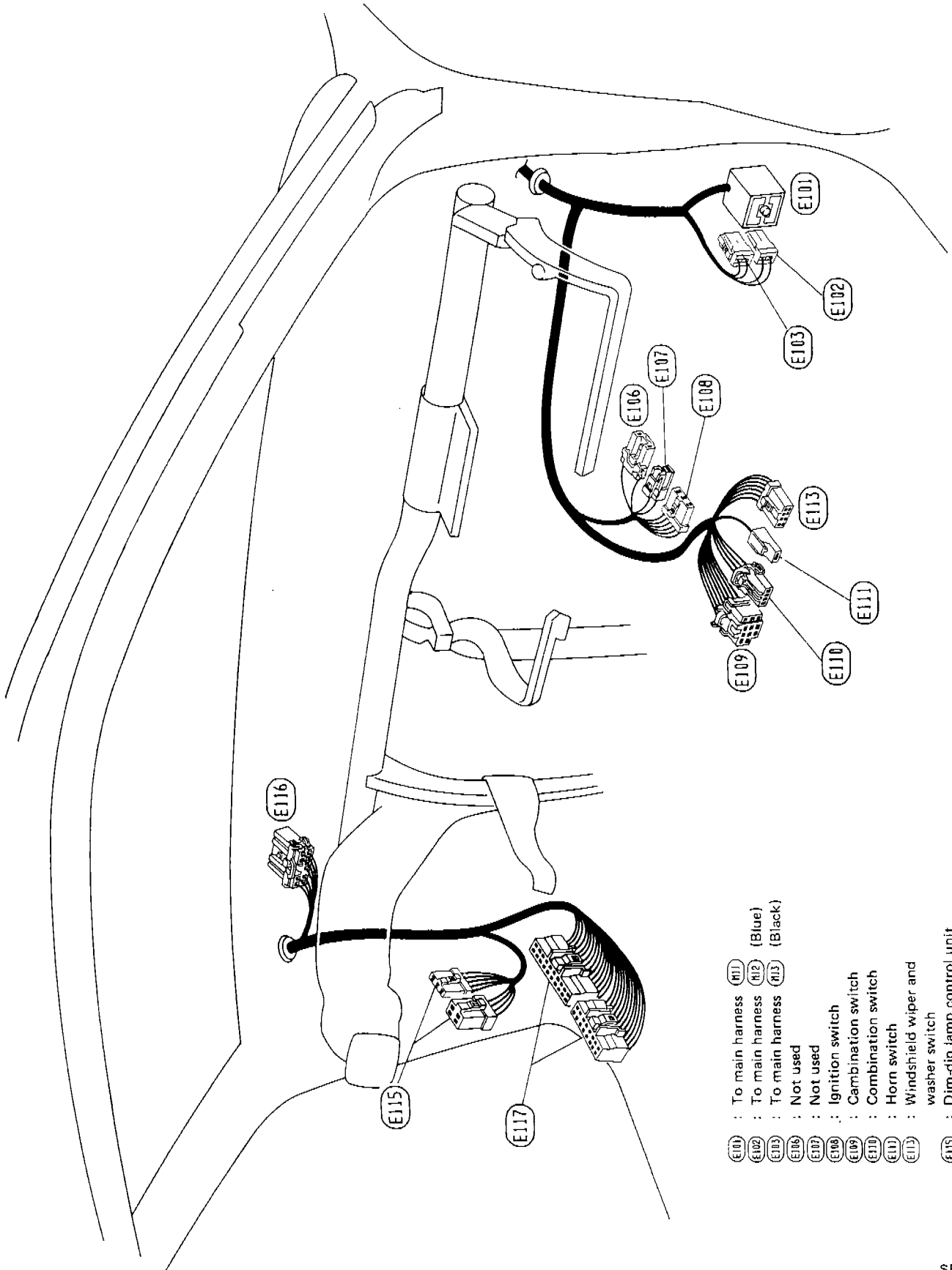

- (E101) : To main harness (H11) (Blue)
- (E102) : To main harness (H12) (Black)
- (E103) : To main harness (H13)
- (E104) : Not used
- (E105) : Not used
- (E106) : Ignition switch
- (E107) : Combination switch
- (E108) : Combination switch
- (E109) : Horn switch
- (E110) : Windshield wiper and washer switch
- (E111) : Dim-dip lamp control unit
- (E112) : To E.F.I. harness (E3)
- (E113) : A/T control unit

HARNESS LAYOUT

Engine Room Harness No. 2

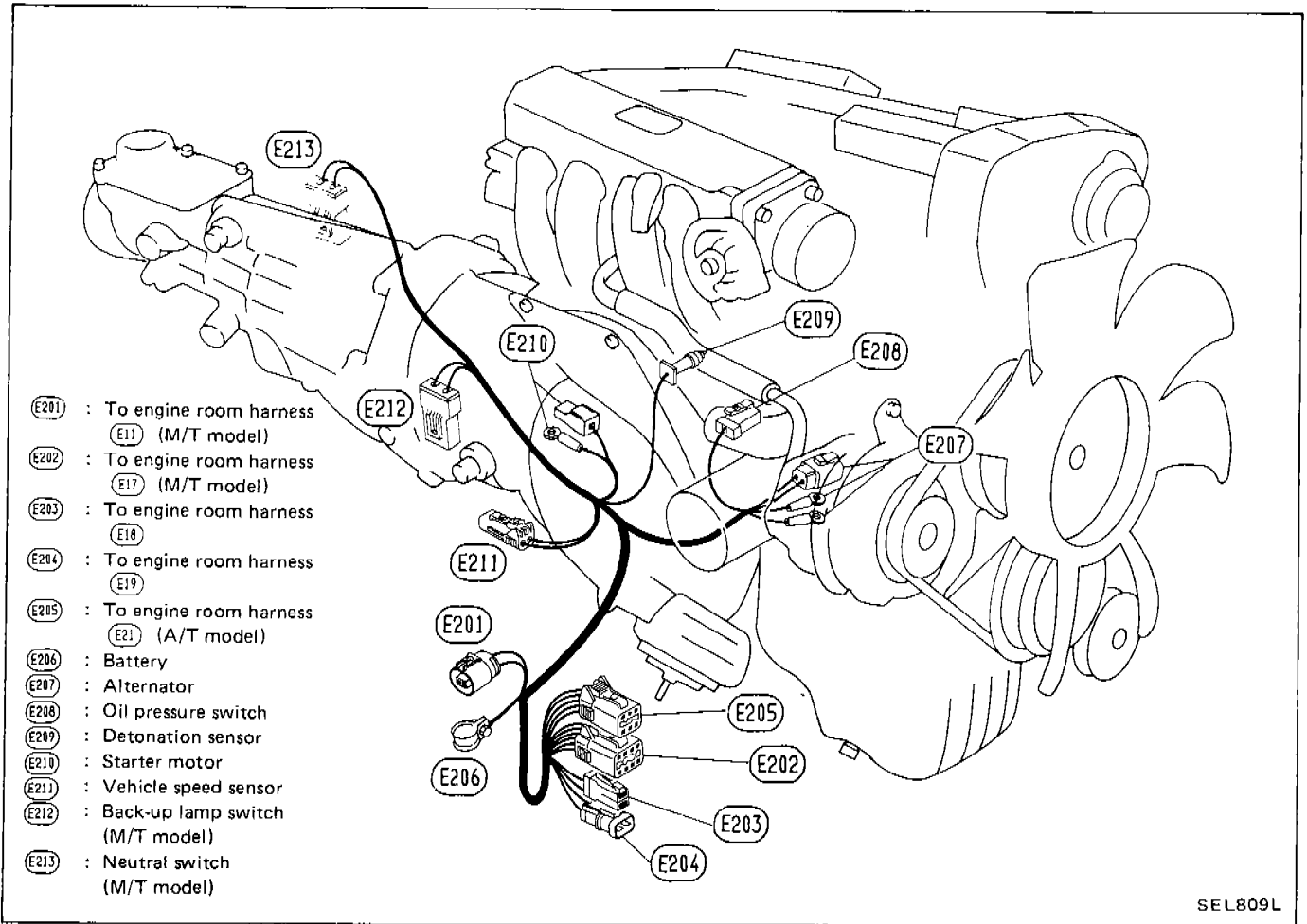

SEL809L

HARNESS LAYOUT

E.F.I. Harness

L.H. DRIVE MODEL

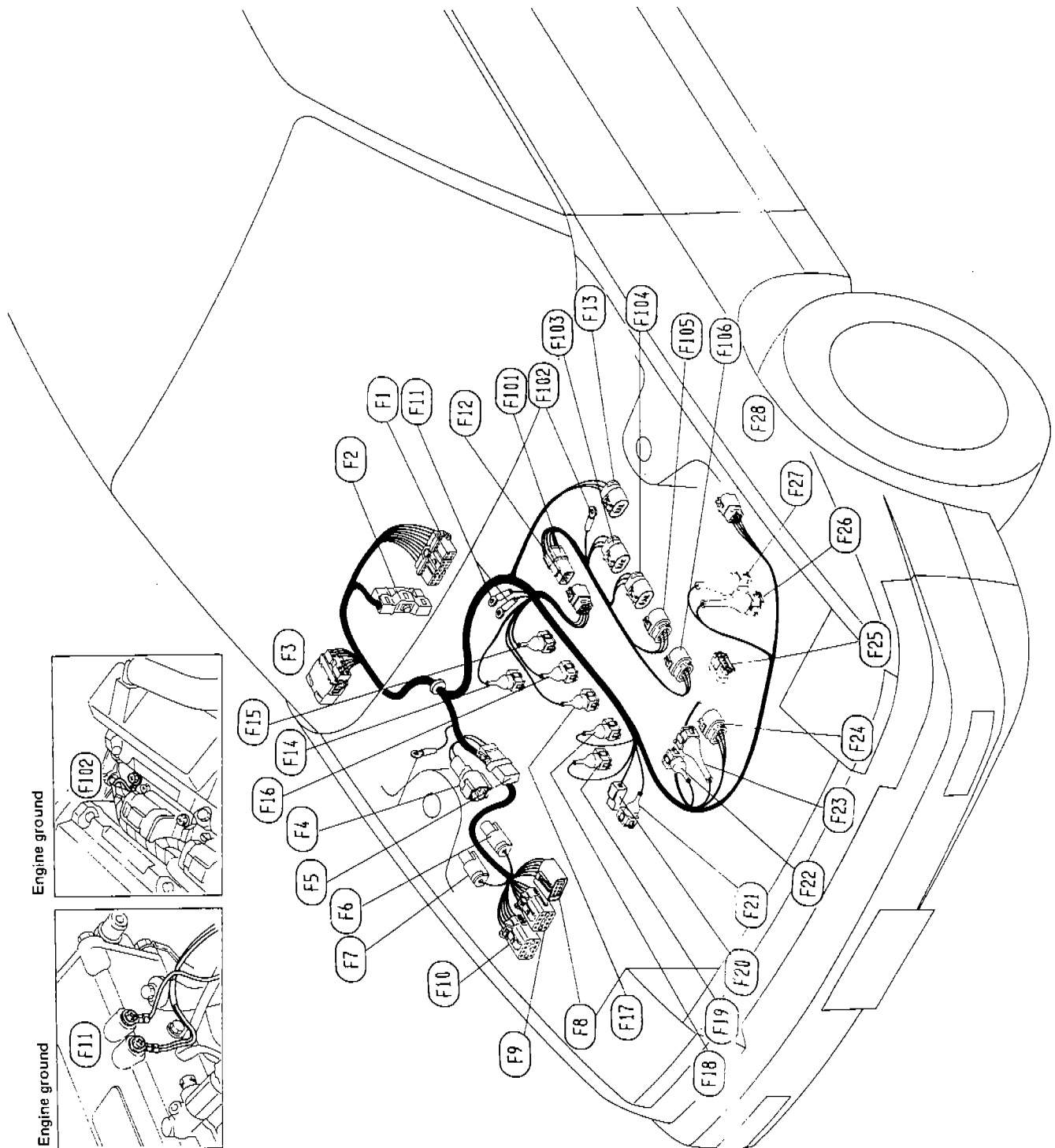

HARNES LAYOUT

E.F.I. Harness (Cont'd)

- F1 : To main harness (653)
- F2 : E.C.C.S. control unit
- F3 : To engine room harness (E16)
- F4 : Front brake skid sensor R.H.
- F5 : Resistor
- F6 : Check connector
- F7 : Check connector
- F8 : To engine room harness (E8) (White)
- F9 : To engine room harness (E9) (Gray)
- F10 : To engine room harness (E10) (Brown)
- F11 : Engine ground
- F12 : To ignition coil sub-harness (F11)
- F13 : Exhaust gas sensor (For model with catalyzer)
- F14 : F.I.C.D. solenoid valve
- F15 : Injector-4
- F16 : Injector-3
- F17 : Injector-2
- F18 : Injector-1
- F19 : A.A.C. solenoid valve
- F20 : Thermal transmitter
- F21 : Engine temperature sensor
- F22 : Air regulator
- F23 : Throttle valve switch
- F24 : Throttle sensor
- F25 : Crank angle sensor
- F26 : Air flow meter (For model with catalyzer)
- F27 : Air flow meter (Except for model with catalyzer)
- F28 : Dropping resistor
- F29 : To E.F.I. harness (F12)
- F30 : Engine ground
- F31 : Ignition coil-4
- F32 : Ignition coil-3
- F33 : Ignition coil-2
- F34 : Ignition coil-1

HARNES LAYOUT

E.F.I. Harness (Cont'd)

R.H. DRIVE MODEL

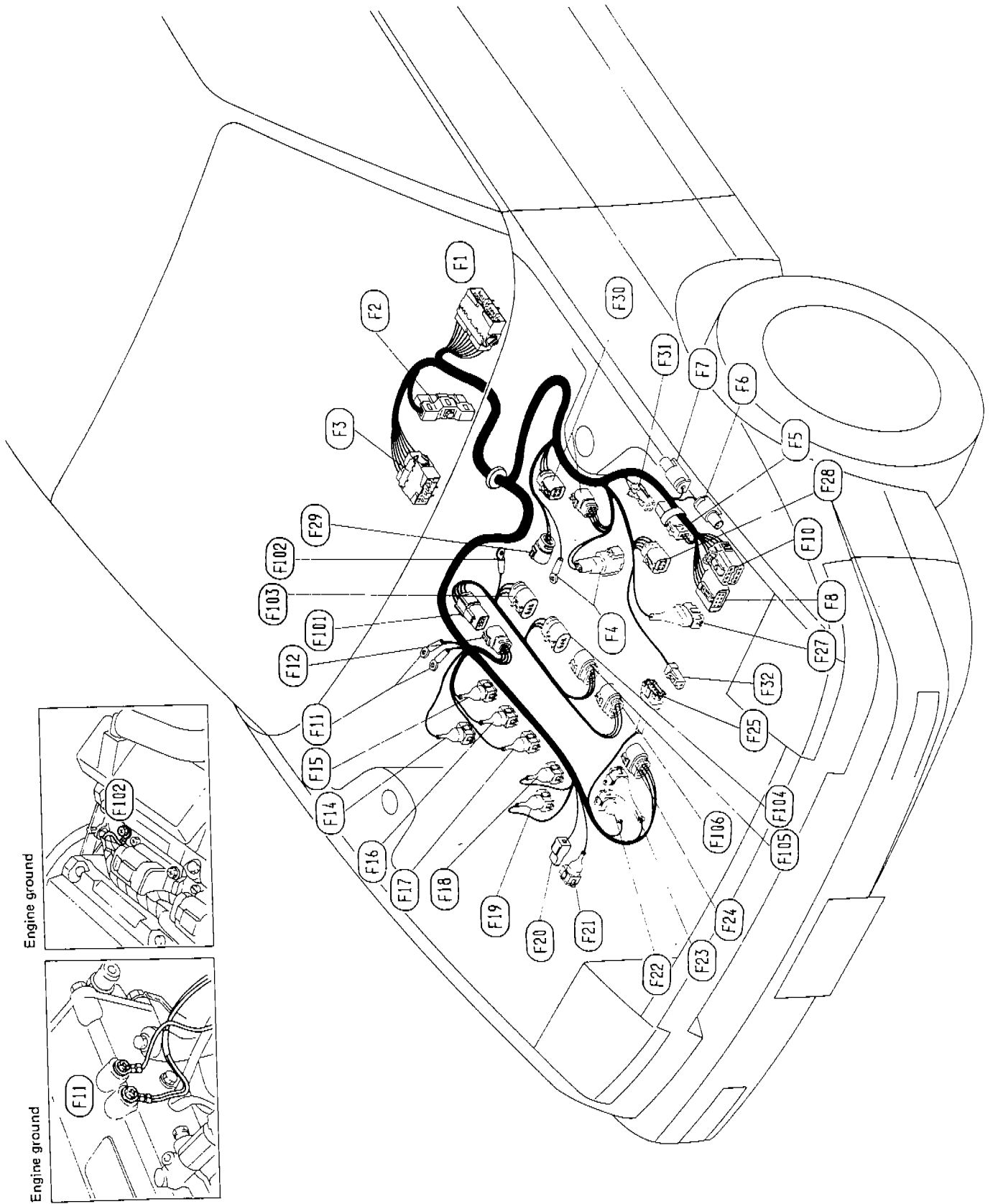

HARNES LAYOUT

E.F.I. Harness (Cont'd)

(F1) : To main harness (MS3)
(F2) : E.C.S. control unit
(E1) : To engine room harness (E16)
(F4) : Front brake skid sensor L.H.
(F5) : Resistor
(F6) : Check connector
(F7) : Check connector
(F8) : To engine room harness (E1) (White)
(F10) : To engine room harness (E10) (Brown)
(F11) : Engine ground
(F12) : To ignition coil sub-harness (F101)
(F14) : F.I.C.D. solenoid valve
(F15) : Injector-4
(F16) : Injector-3
(F17) : Injector-2
(F18) : Injector-1
(F19) : A.A.C. solenoid valve
(F20) : Thermal transmitter

(F21) : Engine temperature sensor
(E22) : Air regulator
(F23) : Throttle valve switch
(E24) : Throttle sensor
(F25) : Crank angle sensor
(F27) : Air flow meter
(F28) : Dropping resistor
(F29) : Pressure regulator control solenoid valve
(F30) : Power transistor unit
(E31) : Dropping resistor (A/T model)
(F32) : Compressor
(F101) : To E.F.I. harness (F12)
(F102) : Engine ground
(F103) : Ignition coil-4
(F104) : Ignition coil-3
(F105) : Ignition coil-2
(F106) : Ignition coil-1

SUPER MULTIPLE JUNCTION (S.M.J.)

REMOVAL

- Remove fuse block retaining screws to gain access to S.M.J.
- Slide fuse block to the side, and remove S.M.J. retaining bolts to detach S.M.J.

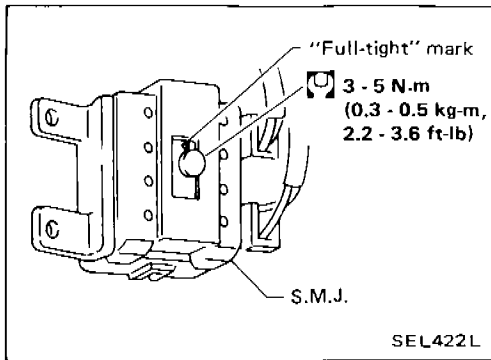

INSTALLATION

To install S.M.J., tighten bolts until orange "full-tight" mark appears and then retighten to specified torque as required.

□: 3 - 5 N·m
(0.3 - 0.5 kg-m, 2.2 - 3.6 ft-lb)

CAUTION:

Do not overtighten bolts, otherwise, they may be damaged.

HARNESS LAYOUT

Back Door Harness

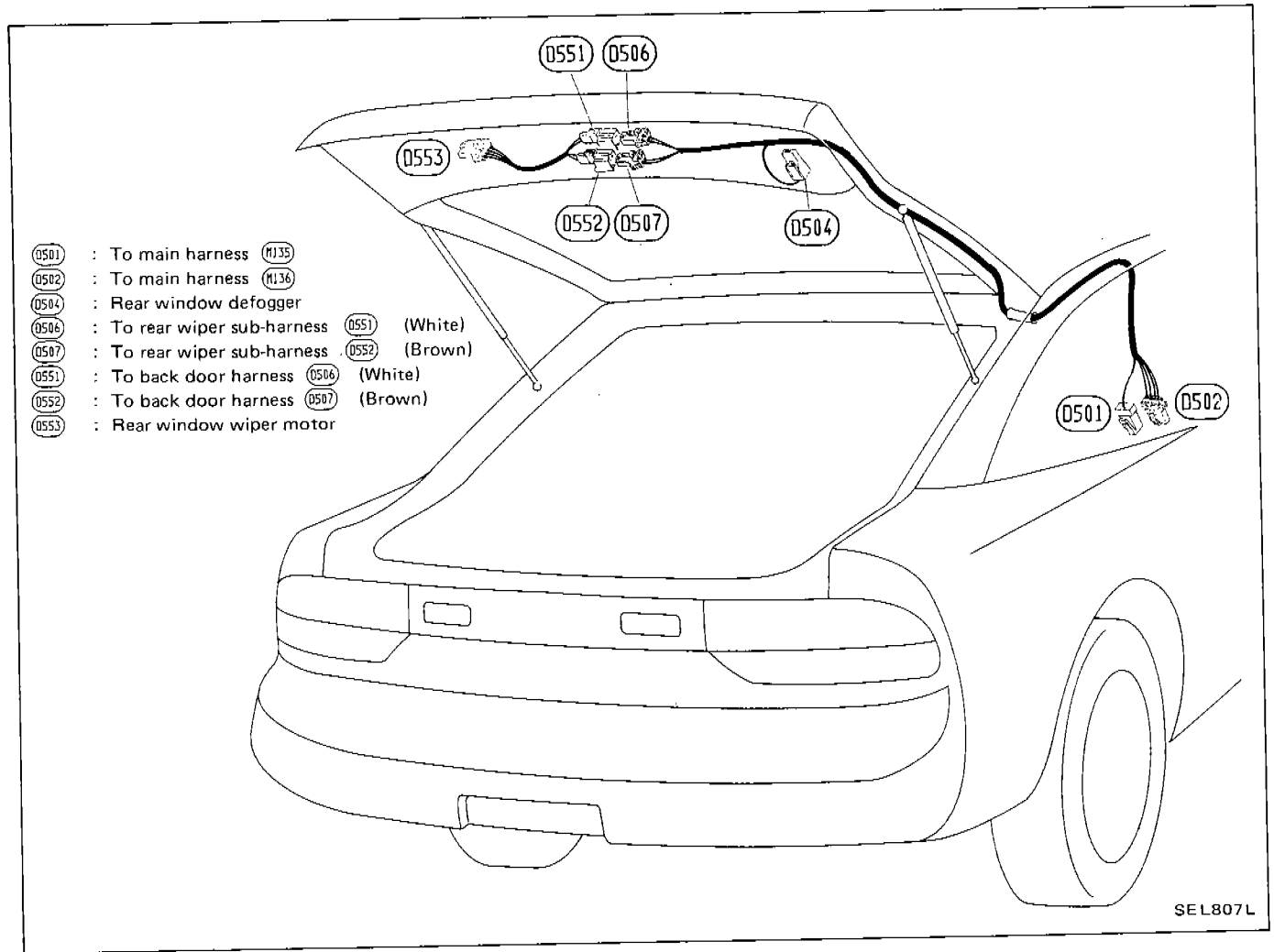

SUPER MULTIPLE JUNCTION (S.M.J.)

REMOVAL

- Remove fuse block retaining screws to gain access to S.M.J.
- Slide fuse block to the side, and remove S.M.J. retaining bolts to detach S.M.J.

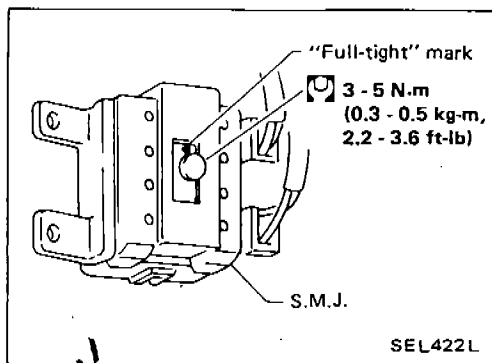

INSTALLATION

To install S.M.J., tighten bolts until orange "full-tight" mark appears and then retighten to specified torque as required.

□: 3 - 5 N·m
(0.3 - 0.5 kg-m, 2.2 - 3.6 ft-lb)

CAUTION:

Do not overtighten bolts, otherwise, they may be damaged.

SUPER MULTIPLE JUNCTION (S.M.J.)

Terminal Arrangement

MAIN HARNESS

| | | | | | | | | | | | |
|----|----|----|----|----|----|----|----|----|-----|-----|-----|
| A1 | A2 | A3 | A4 | A5 | A6 | A7 | A8 | A9 | A10 | A11 | A12 |
| B1 | B2 | B3 | B4 | B5 | B6 | B7 | B8 | B9 | B10 | B11 | B12 |
| C1 | C2 | C3 | C4 | C5 | C6 | C7 | C8 | C9 | C10 | C11 | C12 |
| D1 | D2 | | | | | | | | | D11 | D12 |
| E1 | E2 | | | | | | | | | E11 | E12 |
| F1 | F2 | | | | | | | | | F11 | F12 |
| G1 | G2 | G3 | G4 | G5 | G6 | G7 | G8 | G9 | G10 | G11 | G12 |
| H1 | H2 | H3 | H4 | H5 | H6 | H7 | H8 | H9 | H10 | H11 | H12 |
| I1 | I2 | I3 | I4 | I5 | I6 | I7 | I8 | I9 | I10 | I11 | I12 |



| | | | | | | | | | | | |
|----|----|----|----|----|----|----|----|----|-----|-----|-----|
| I1 | I2 | I3 | I4 | I5 | I6 | I7 | I8 | I9 | I10 | I11 | I12 |
| H1 | H2 | H3 | H4 | H5 | H6 | H7 | H8 | H9 | H10 | H11 | H12 |
| G1 | G2 | G3 | G4 | G5 | G6 | G7 | G8 | G9 | G10 | G11 | G12 |
| F1 | F2 | | | | | | | | | F11 | F12 |
| E1 | E2 | | | | | | | | | E11 | E12 |
| D1 | D2 | | | | | | | | | D11 | D12 |
| C1 | C2 | C3 | C4 | C5 | C6 | C7 | C8 | C9 | C10 | C11 | C12 |
| B1 | B2 | B3 | B4 | B5 | B6 | B7 | B8 | B9 | B10 | B11 | B12 |
| A1 | A2 | A3 | A4 | A5 | A6 | A7 | A8 | A9 | A10 | A11 | A12 |

ENGINE ROOM HARNESS

E.C.C.S. CONTROL UNIT

| | | | | | | | | | | | | | | | | | | | | | | | | | | | | | | | | | | | | | |
|-----|-----|-----|-----|-----|-----|-----|-----|----|----|----|----|----|----|----|----|----|----|----|----|----|----|----|----|----|----|----|----|----|----|----|----|----|----|----|----|----|----|
| 101 | 102 | 103 | 104 | 105 | 106 | 107 | 108 | 1 | 2 | 3 | 4 | 5 | 6 | 7 | 8 | 9 | 10 | 21 | 22 | 23 | 24 | 25 | 26 | 27 | 28 | 29 | 30 | 41 | 42 | 43 | 44 | 45 | 46 | 47 | 48 | 49 | 50 |
| 109 | 110 | 111 | 112 | 113 | 114 | 115 | 116 | 11 | 12 | 13 | 14 | 15 | 16 | 17 | 18 | 19 | 20 | 31 | 32 | 33 | 34 | 35 | 36 | 37 | 38 | 39 | 40 | 51 | 52 | 53 | 54 | 55 | 56 | 57 | 58 | 59 | 60 |

View from harness side



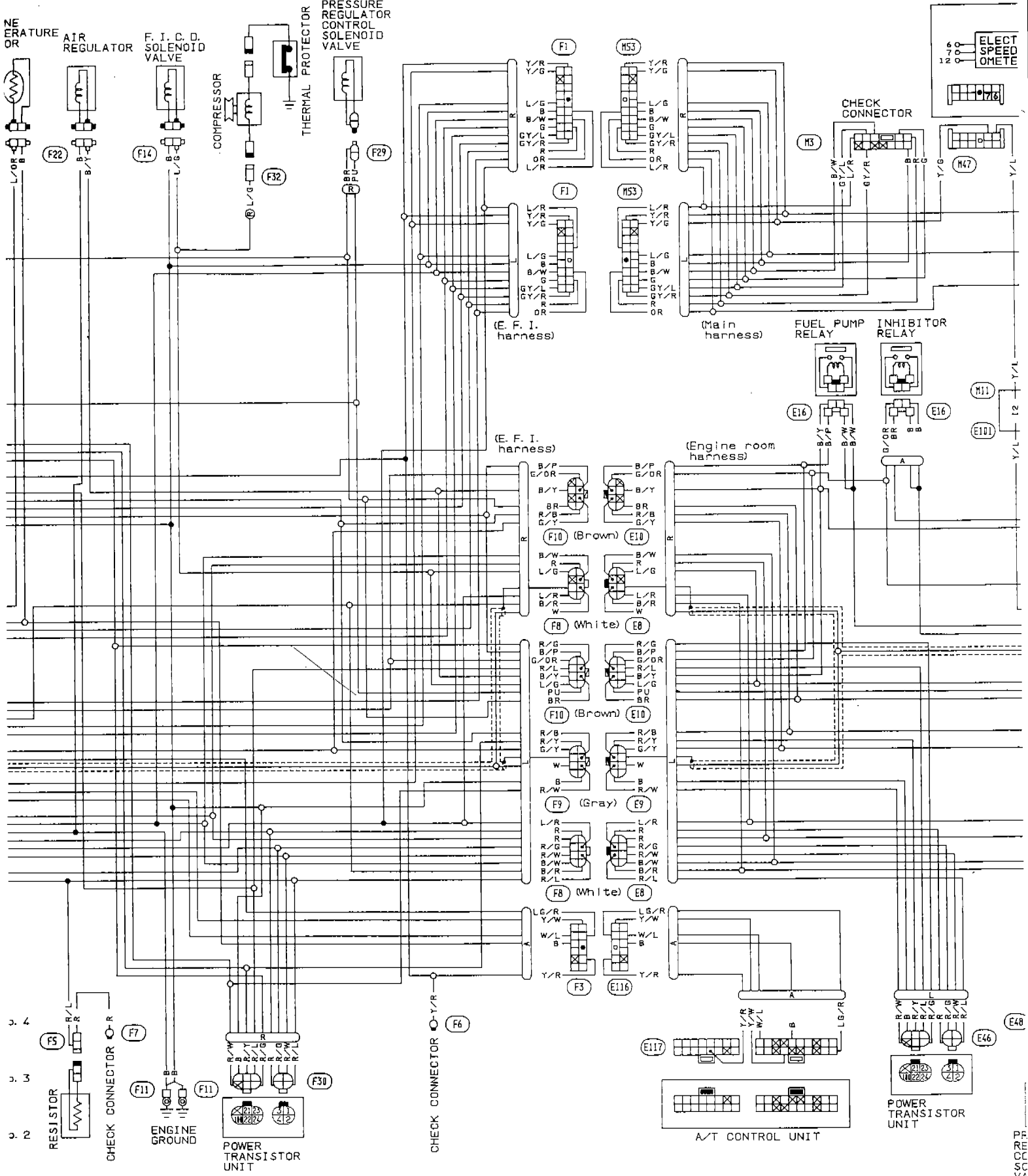

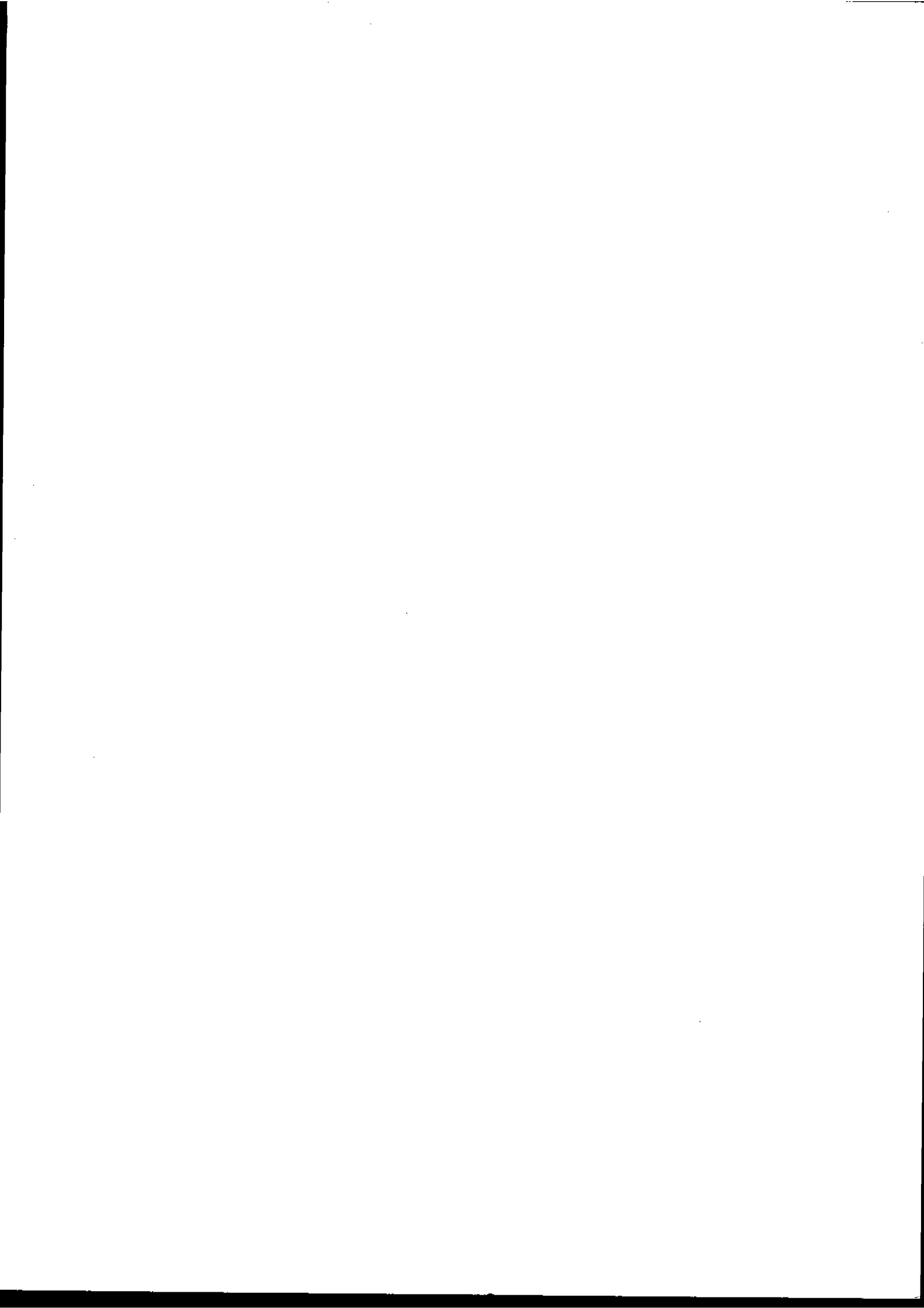

NISSAN 200SX (S13 series) CIRCUIT DIAGRAM

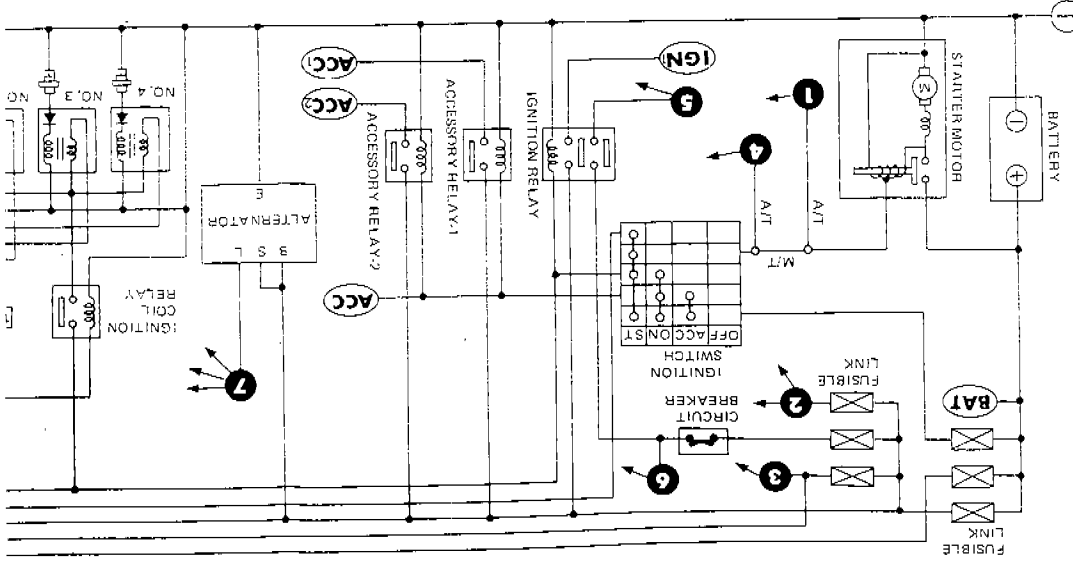
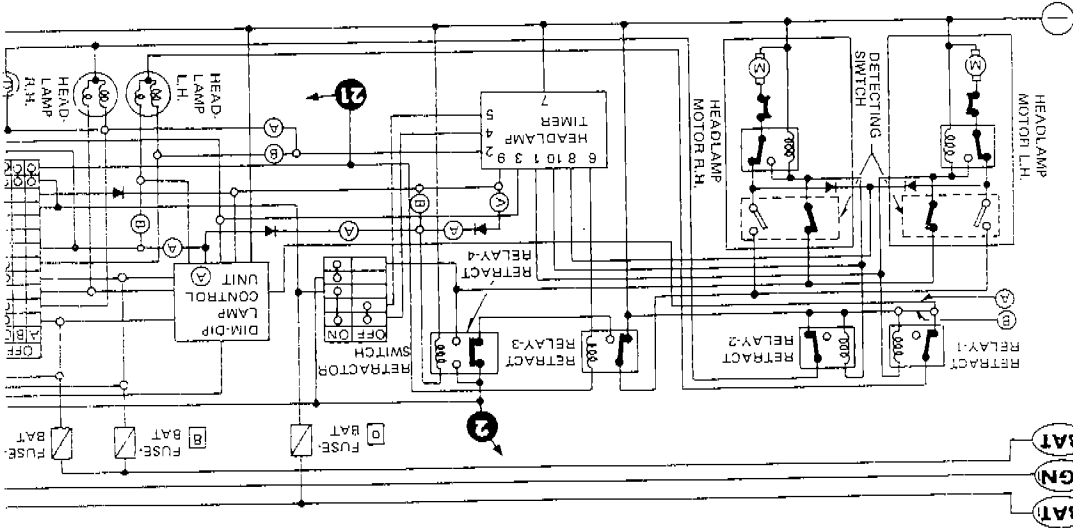
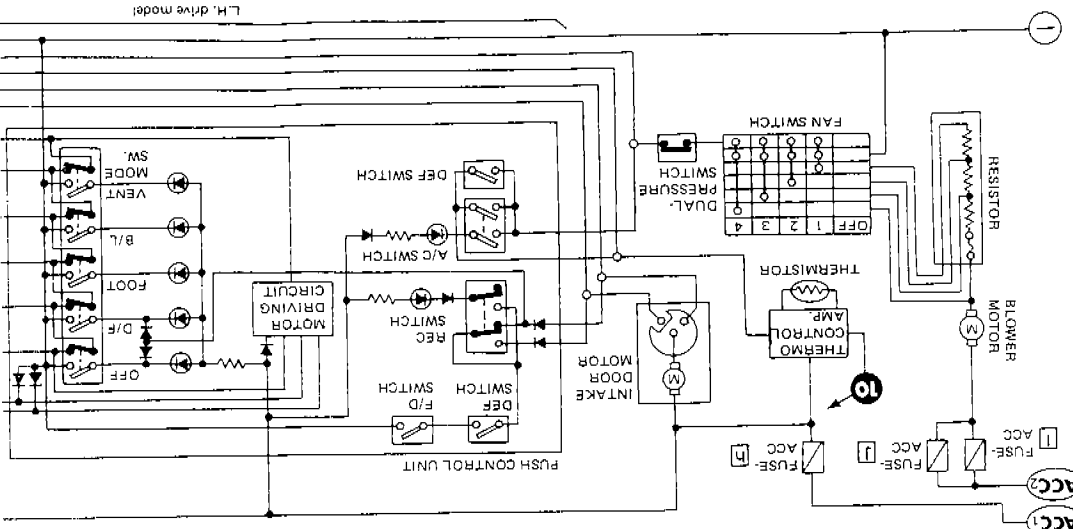
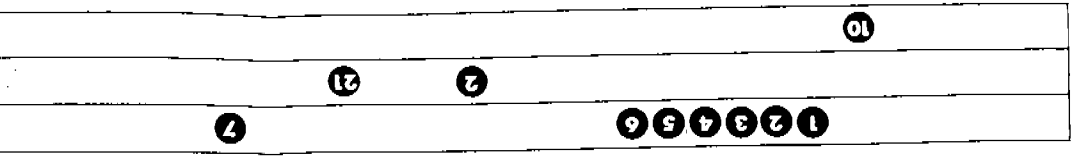



11-11-11

11



REV 10/88
DIE

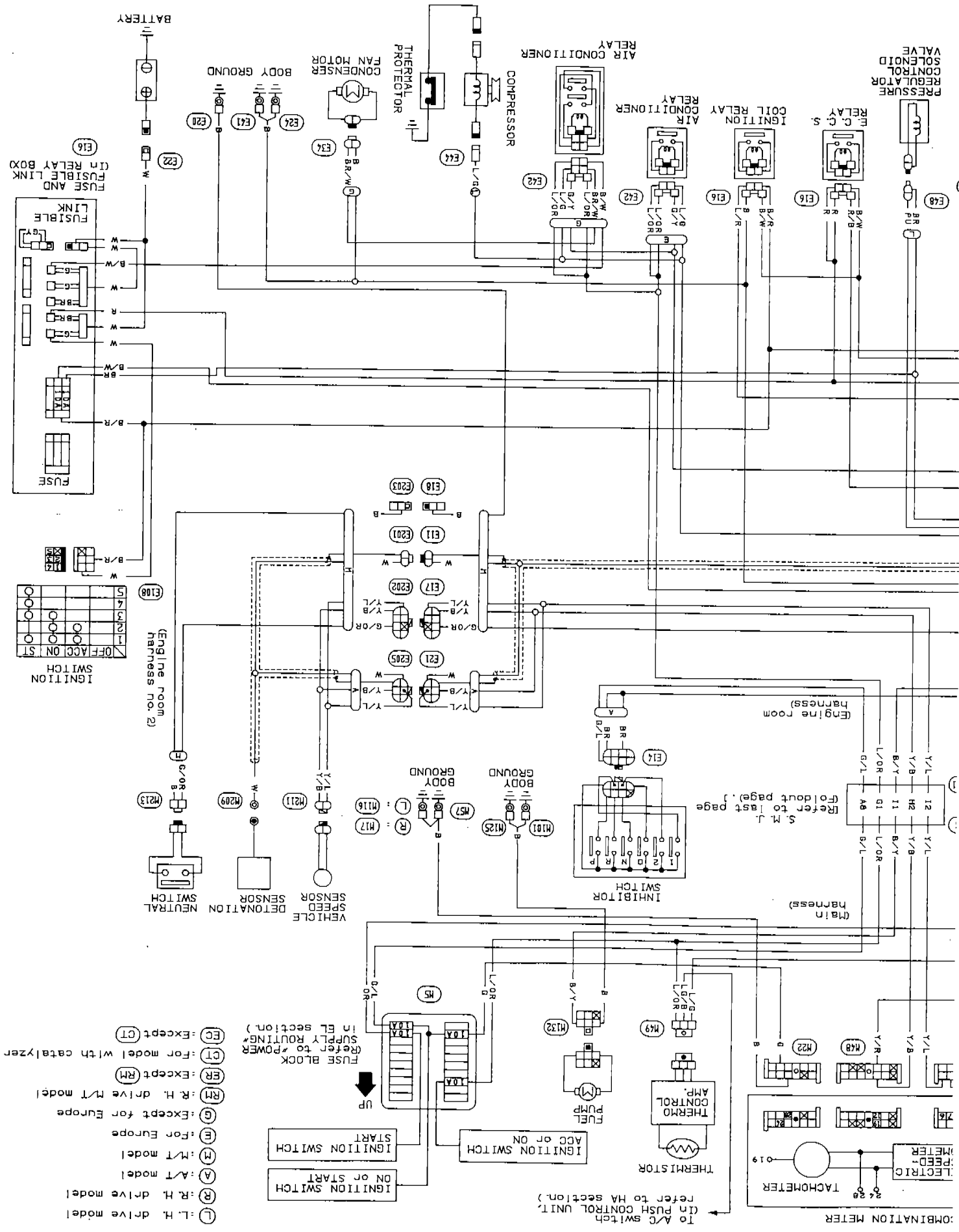

- (L) L.H. drive model
- (R) R.H. drive model
- (A) A.T. model
- (H) M.T. model
- (E) For Europe
- (G) Except for Europe
- (RM) R.H. drive M.T. model
- (ER) Except RM
- (CT) For model with catalyzer
- (EC) Except CT

FUSE BLOCK
(refer to POWER SUPPLY ROUTING in EL section.)

To A/C switch (in push control unit, refer to HA section.)

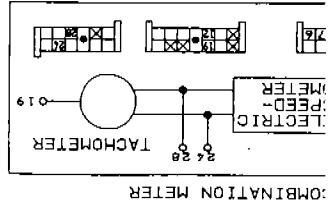

S.M.J.
(Refer to last page.)

(Engine room harness no. 2)

(Engine room harness)

(In harness)

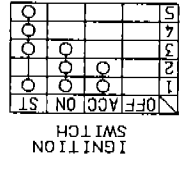
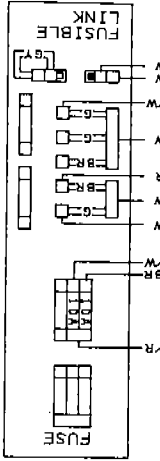

COMBINATION METER

ELECTRIC FEED METER

TACHOMETER

THERMISTOR

THERMO CONTROL AMP.

FUEL PUMP

INHIBITOR SWITCH

VEHICLE SPEED SENSOR

NEUTRAL SWITCH

DETONATION SENSOR

IGNITION SWITCH ON or START

IGNITION SWITCH ACC or ON

IGNITION SWITCH START

PRESSURE REGULATOR CONTROL SOLENOID VALVE

E.C.S. RELAY

IGNITION COIL RELAY

AIR CONDITIONER RELAY

AIR CONDITIONER RELAY

COMPRESSOR

THERMAL PROTECTOR

CONDENSER FAN MOTOR

BATTERY



NISSAN 200SX E. C. C. S. WIRING DIAGRAM

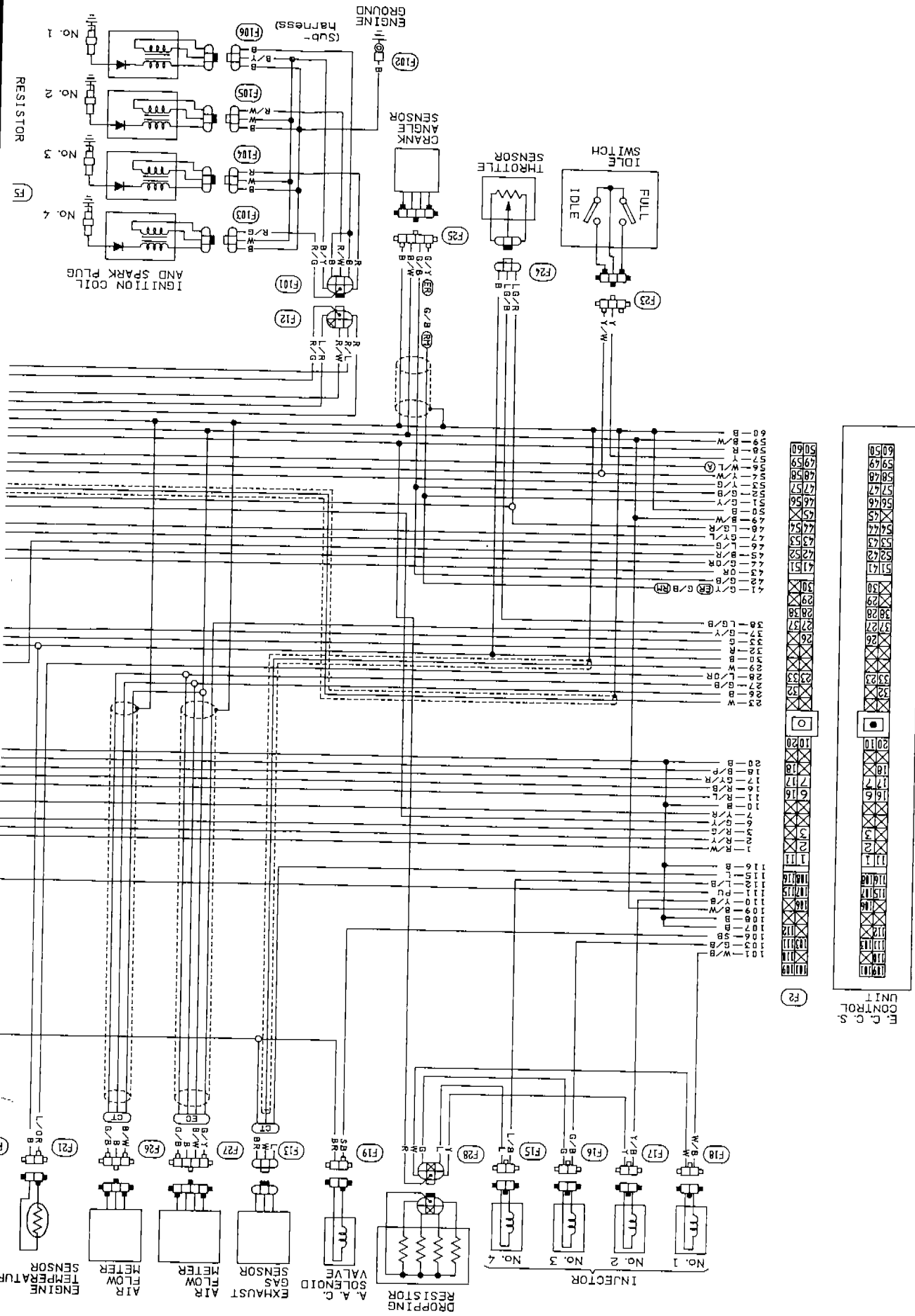

100
101
102
103
104
105
106
107
108
109
110
111
112
113
114
115
116
117
118
119
120
121
122
123
124
125
126
127
128
129
130
131
132
133
134
135
136
137
138
139
140
141
142
143
144
145
146
147
148
149
150
151
152
153
154
155
156
157
158
159
160
161
162
163
164
165
166
167
168
169
170
171
172
173
174
175
176
177
178
179
180
181
182
183
184
185
186
187
188
189
190
191
192
193
194
195
196
197
198
199
200

